

**MATERIALS**

<b>BODY</b>	<b>BRASS NICKEL PLATED</b>
<b>CONTACT</b>	<b>SILVER PLATED</b>
<b>INSULATOR</b>	<b>PTFE</b>

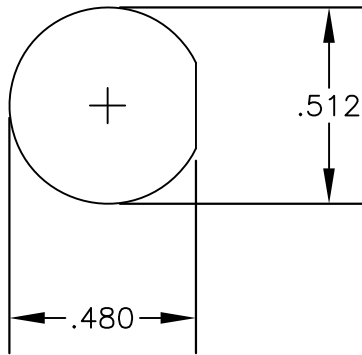

MOUNTING HOLE

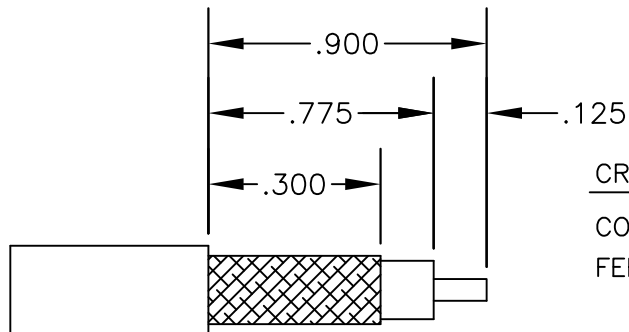
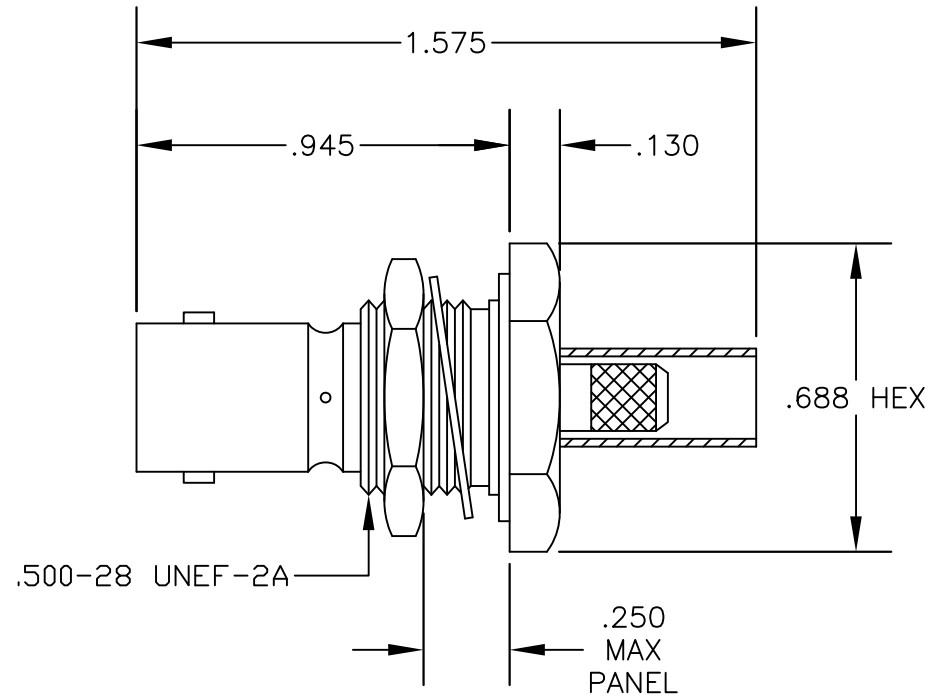

STRIPPING DIMENSIONS

CRIMP SIZE REQUIRED

CONTACT: SOLDER

FERRULE: .213" HEX CRIMP TOOL



**PASTERNACK ENTERPRISES, INC.**

P.O BOX 16759, IRVINE, CA 92623  
PHONE (949) 261-1920 FAX (949) 261-7451

WEB ADDRESS: [www.pasternack.com](http://www.pasternack.com)  
E-MAIL ADDRESS: [sales@pasternack.com](mailto:sales@pasternack.com)

**COAXIAL & FIBER OPTICS**

DWG TITLE  
**PE44107**

DES. MHV FEMALE, BULKHEAD, CRIMP  
ATTACHMENT FOR RG55, RG141, RG142,  
RG223 & RG400

REV. A	<b>FSCM NO. 53919</b>	CAD FILE 042210	SCALE N/A	SIZE A	147
--------	-----------------------	-----------------	-----------	--------	-----

- NOTES:**
1. UNLESS OTHERWISE SPECIFIED ALL DIMENSIONS ARE NOMINAL.
  2. ALL SPECIFICATIONS ARE SUBJECT TO CHANGE WITHOUT NOTICE AT ANY TIME.
  3. DIMENSIONS ARE IN INCHES.