

DO NOT SCALE FROM THIS PRINT

- NOTES:  
 1. VITA 57 CONNECTOR.  
 2. Ⓢ REPRESENTS A CRITICAL DIMENSION.  
 3. MINIMUM PUSHOUT FORCE: 0.50 LBS.  
 4. PARTS TO BE PACKAGED IN TAPE AND REEL.  
 5. NOTE DELETED.  
 6. DIMENSION C10 MUST BE MEASURED USING INSPECTION FIXTURE AT-1817-836-2, USE CO-AU-WI-2003-M FOR PROCESS.  
 7. ATTACH LABEL "SEAX-0001" TO EACH TAPE & REEL PACKAGE.  
 8. MAXIMUM ROW TO ROW VARIATION .003[0.08], MEASURED FIRST & LAST POSITIONS ONLY, ALL ROWS

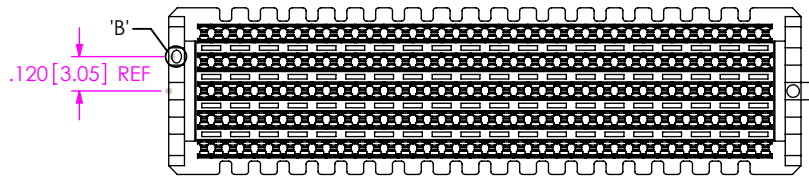
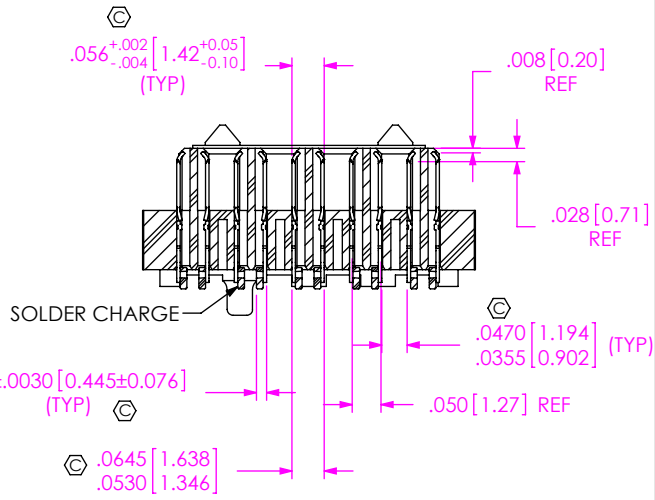
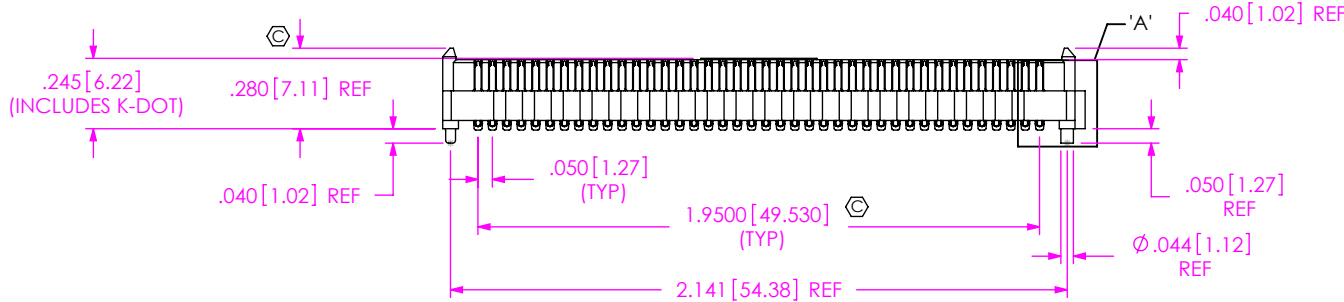
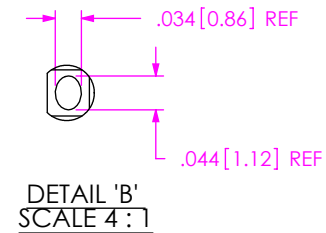
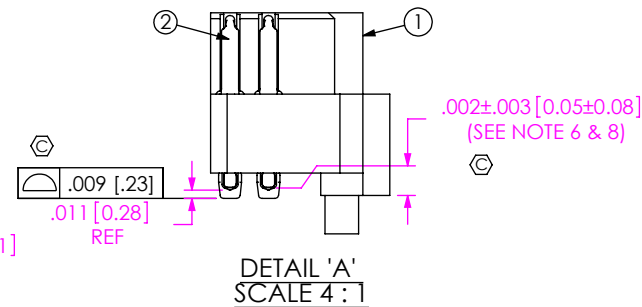
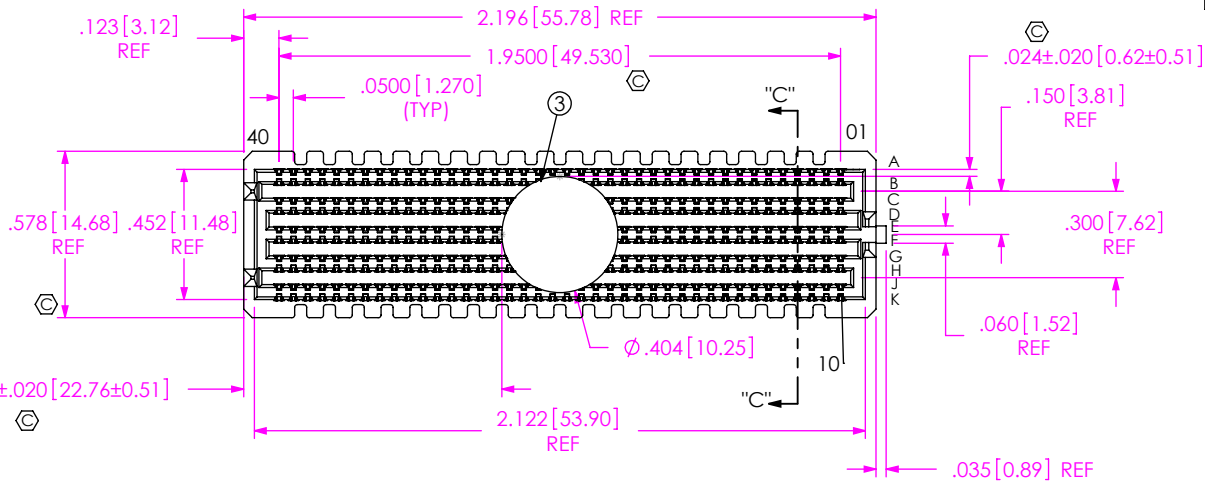

ITEM NO.	PART NUMBER	QUANTITY	MATERIAL
1	SEAM-40-03.5-10-A	1.0000	LCP, UL 94 V0, COLOR: BLACK
2	NEW-SUB-T-1M36-03.5-S-2	400.00	COPPER ALLOY / LEAD FREE SOLDER
3	K-DOT-.404-.500-.005	1.0000	POLYIMIDE FILM
4	CT-SEAM033MS	1.0000	CONDUCTIVE POLYMER

UNLESS OTHERWISE SPECIFIED, DIMENSIONS ARE IN INCHES. TOLERANCES ARE:  
 DECIMALS ANGLES  
 .XX: ±.01[.3] 2°  
 .XXX: ±.005[.13]  
 .XXXX: ±.0020[.051]

PROPRIETARY NOTE  
 THIS DOCUMENT CONTAINS INFORMATION CONFIDENTIAL AND PROPRIETARY TO SAMTEC, INC. AND SHALL NOT BE REPRODUCED OR TRANSFERRED TO OTHER DOCUMENTS OR DISCLOSED TO OTHERS OR USED FOR ANY PURPOSE OTHER THAN THAT WHICH IT WAS OBTAINED WITHOUT THE EXPRESSED WRITTEN CONSENT OF SAMTEC, INC.



520 PARK EAST BLVD. NEW ALBANY, IN 47150  
 PHONE: 812-944-6733 FAX: 812-948-5047  
 e-Mail info@SAMTEC.com code 55322

DO NOT SCALE DRAWING SHEET SCALE: 1.5:1  
 PLATING:  
 CONTACT AREA: .000030 GOLD OVER .000050 NICKEL  
 REMAINDER: .000200 REF TIN OVER .000050 NICKEL

DESCRIPTION:  
 .050 PITCH TERMINAL ARRAY ASSEMBLY  
 DWG. NO. ASP-134488-01  
 BY: G. PURVIS 11/02/2007 SHEET 1 OF 4

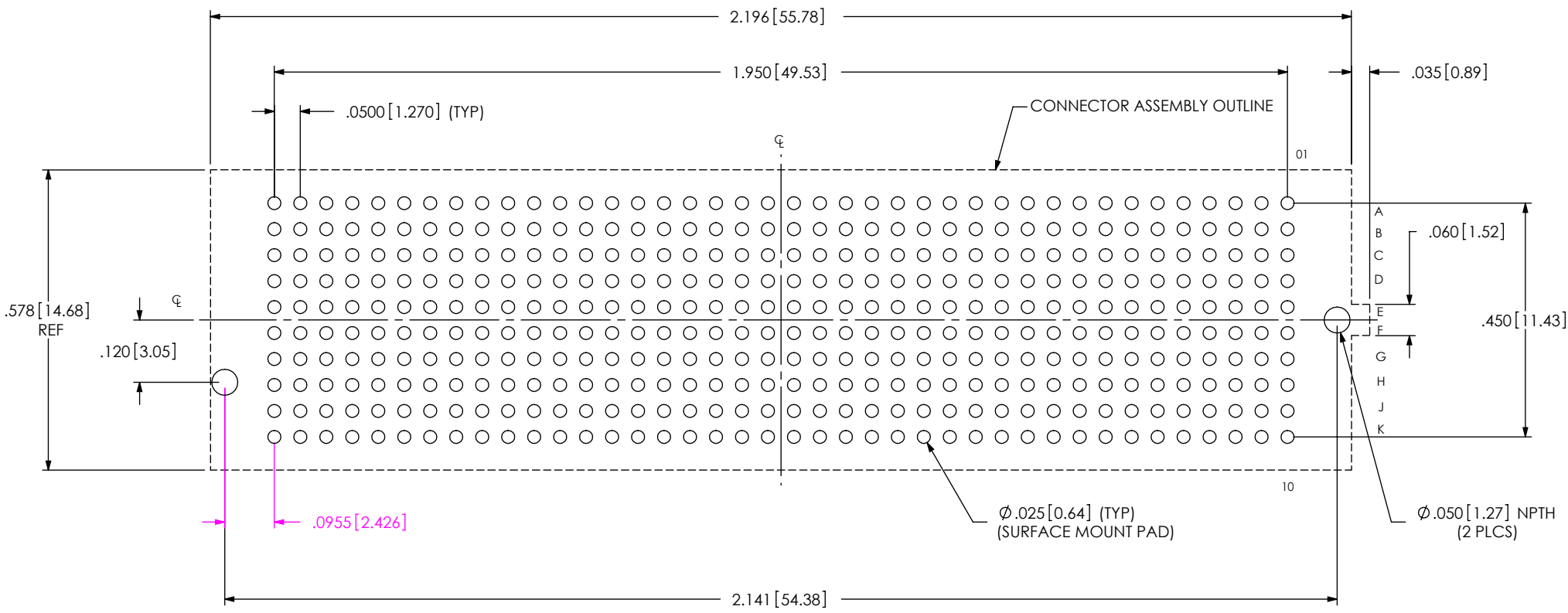

ALL DIMENSIONS ARE SYMMETRIC ABOUT THE CENTERLINE.

**PROPRIETARY NOTE**  
 THIS DOCUMENT CONTAINS INFORMATION  
 CONFIDENTIAL AND PROPRIETARY TO  
 SAMTEC, INC. AND SHALL NOT BE REPRODUCED  
 OR TRANSFERRED TO OTHER DOCUMENTS OR  
 DISCLOSED TO OTHERS OR USED FOR ANY  
 PURPOSE OTHER THAN THAT WHICH IT WAS  
 OBTAINED WITHOUT THE EXPRESSED WRITTEN  
 CONSENT OF SAMTEC, INC.



520 PARK EAST BLVD, NEW ALBANY, IN 47150  
 PHONE: 812-944-6733 FAX: 812-948-5047  
 e-Mail info@SAMTEC.com code 55322

NOTES:  
STENCIL TO BE .0060[.152] THICK.

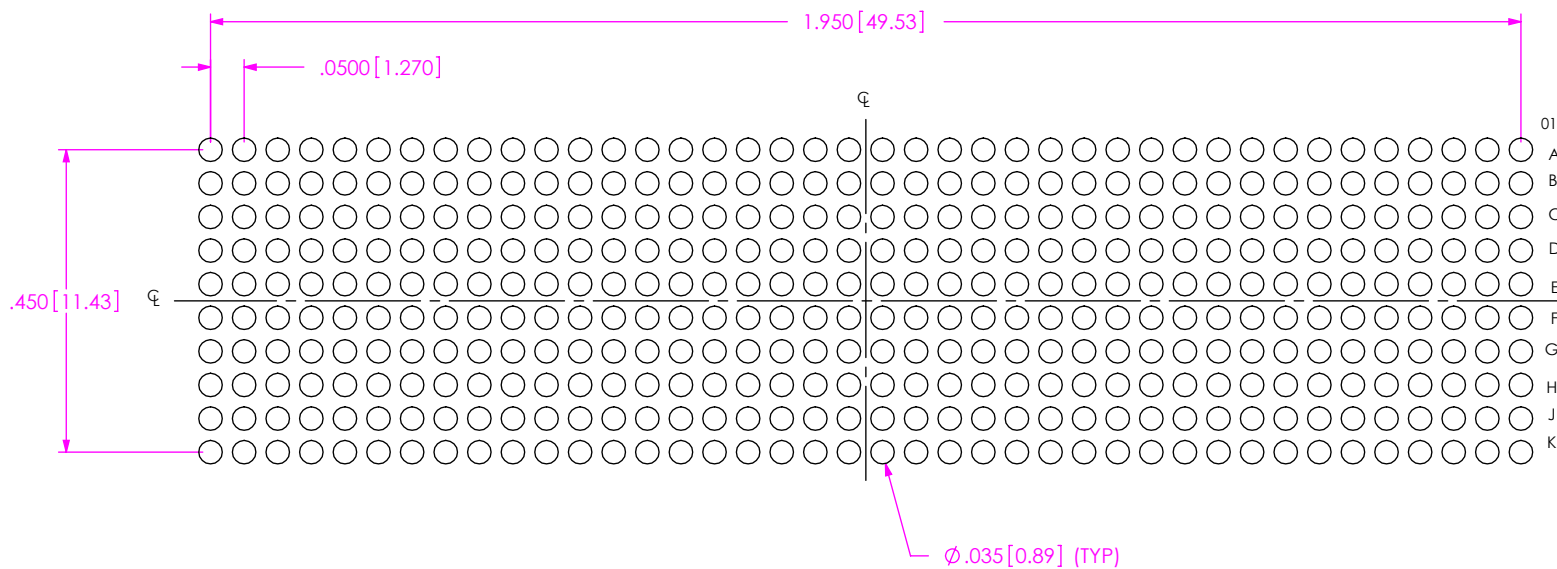

ALL DIMENSIONS ARE SYMMETRIC ABOUT THE CENTERLINE.

**PROPRIETARY NOTE**  
 THIS DOCUMENT CONTAINS INFORMATION  
 CONFIDENTIAL AND PROPRIETARY TO  
 SAMTEC, INC. AND SHALL NOT BE REPRODUCED  
 OR TRANSFERRED TO OTHER DOCUMENTS OR  
 DISCLOSED TO OTHERS OR USED FOR ANY  
 PURPOSE OTHER THAN THAT WHICH IT WAS  
 OBTAINED WITHOUT THE EXPRESSED WRITTEN  
 CONSENT OF SAMTEC, INC.



520 PARK EAST BLVD, NEW ALBANY, IN 47150  
 PHONE: 812-944-6733 FAX: 812-948-5047  
 e-Mail info@SAMTEC.com code 55322

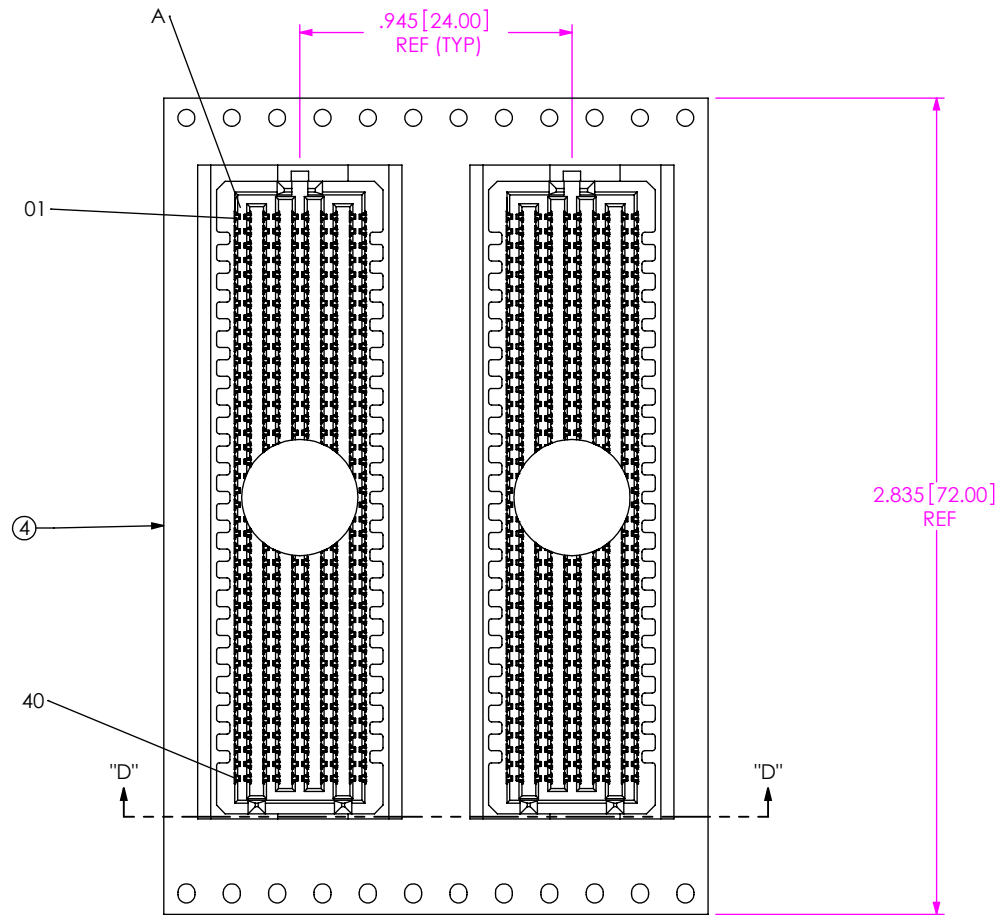

USER DIRECTION OF UN-REELING →  
POCKET NOT DETAILED

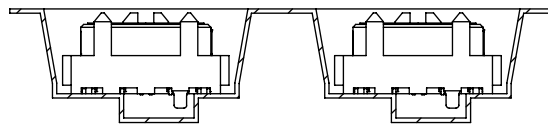

SECTION "D"-"D"  
PACKAGING VIEW

**PROPRIETARY NOTE**

THIS DOCUMENT CONTAINS INFORMATION CONFIDENTIAL AND PROPRIETARY TO SAMTEC, INC. AND SHALL NOT BE REPRODUCED OR TRANSFERRED TO OTHER DOCUMENTS OR DISCLOSED TO OTHERS OR USED FOR ANY PURPOSE OTHER THAN THAT WHICH IT WAS OBTAINED WITHOUT THE EXPRESSED WRITTEN CONSENT OF SAMTEC, INC.



520 PARK EAST BLVD., NEW ALBANY, IN 47150  
PHONE: 812-944-6733 FAX: 812-948-5047  
e-Mail info@SAMTEC.com code 55322

SHEET SCALE: 1.5:1

DESCRIPTION:  
.050 PITCH TERMINAL ARRAY ASSEMBLY

DWG. NO. ASP-134488-01

BY: G. PURVIS 11/02/2007 SHEET 4 OF 4