

Silicon Photodiode, Blue Enhanced Photoconductive (MRD 510) Industry Equivalent Type PDB-C120

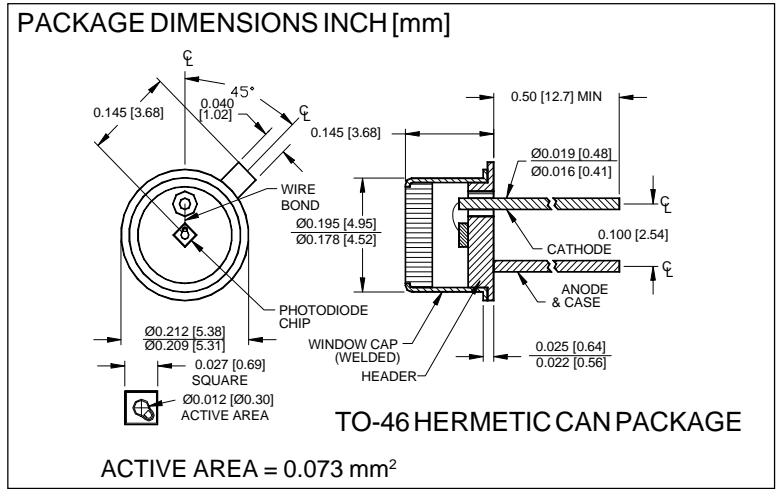

FEATURES

- High speed
- Low capacitance
- Blue enhanced
- Low dark current

DESCRIPTION

The **PDB-C120** is a silicon, PIN planar diffused, blue enhanced photodiode. Ideal for high speed photoconductive applications. Packaged in a hermetic TO-46 metal can with a flat window.

APPLICATIONS

- Fiber optic
- Laser detection
- Light demodulation
- Matched to I.R. LEDs

ABSOLUTE MAXIMUM RATING (TA=25°C unless otherwise noted)

SYMBOL	PARAMETER	MIN	MAX	UNITS
V _{BR}	Reverse Voltage		200	V
T _{STG}	Storage Temperature	-65	+150	°C
T _O	Operating Temperature Range	-55	+125	°C
T _S	Soldering Temperature*		+240	°C
I _L	Light Current		0.5	mA

*1/16 inch from case for 3 secs max

SPECTRAL RESPONSE

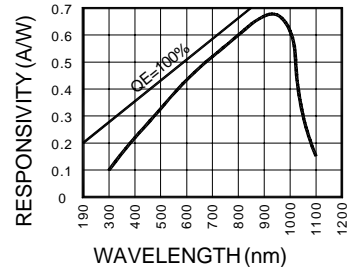

ELECTRO-OPTICAL CHARACTERISTICS (TA=25°C unless otherwise noted)

SYMBOL	CHARACTERISTIC	TEST CONDITIONS	MIN	TYP	MAX	UNITS
I _{SC}	Short Circuit Current	H = 100 fc, 2850 K	1.2	1.5		μA
I _D	Dark Current	H = 0, V _R = 10 V		0.5	2.0	nA
R _{SH}	Shunt Resistance	H = 0, V _R = 10 mV	400	500		MΩ
TCR _{SH}	RSH Temp. Coefficient	H = 0, V _R = 10 mV		-8		% / °C
C _J	Junction Capacitance	H = 0, V _R = 10 V**		1		pF
λ _{range}	Spectral Application Range	Spot Scan	350		1100	nm
λ _p	Spectral Response - Peak	Spot Scan		950		nm
V _{BR}	Breakdown Voltage	I = 10 μA	100	150		V
NEP	Noise Equivalent Power	V _R = 10 V @ Peak		9.0x10 ⁻¹⁵		W/√Hz
tr	Response Time	RL = 1 KΩ V _R = 50 V		1.0		nS

Information in this technical data sheet is believed to be correct and reliable. However, no responsibility is assumed for possible inaccuracies or omission. Specifications are subject to change without notice. **f = 1 MHz