



Current Mode PWM Controller

MC7773N6

Description

MC7773N6 is a highly integrated current mode PWM control IC optimized for high performance low standby power offline flyback converter applications.

To meet the international power conservation requirements, optimized green mode is integrated to improve the efficiency at light or no load conditions with no audible noise.

Slope compensation is integrated to ensure the stability at high load. Lead edge blanking is integrated to prevent the false trigger at the transition of the switch. Soft switching control at the gate drive can improve the EMI performance of the power supply. The Gate-drive output is clamped at 12V to protect the power MOS.

Features

- Frequency jitter function to improve EMI performance of power supply
- No-audible-noise green mode control
- Multi operation mode: Fixed-frequency CCM, green mode and burst mode.
- No load input power under 100mW
- Internal slope compensation
- Low VDD startup current and low operating current
- Leading edge blanking
- UVLO 8.5V / 15.5V
- Gate max output voltage clamp at 12V
- Overload Protection (OLP) with auto-recovery
- Line compensation over current protection (OCP) with auto-recovery
- Over Temperature Protection (OTP) witch latch
- VDD Over Voltage Protection (OVP) witch latch

Applications

Offline AC/DC flyback converter for

- Battery Charger
- Power Adaptor
- Set-Top Box Power Supplies
- Open-frame SMPS
- PC 5V Standby Power

Ordering Information

Device	Package	Shipping
MC7773N6	SOT-23-6L (Pb-free lead plating)	3000 pcs / tape & reel

Typical Application Circuit

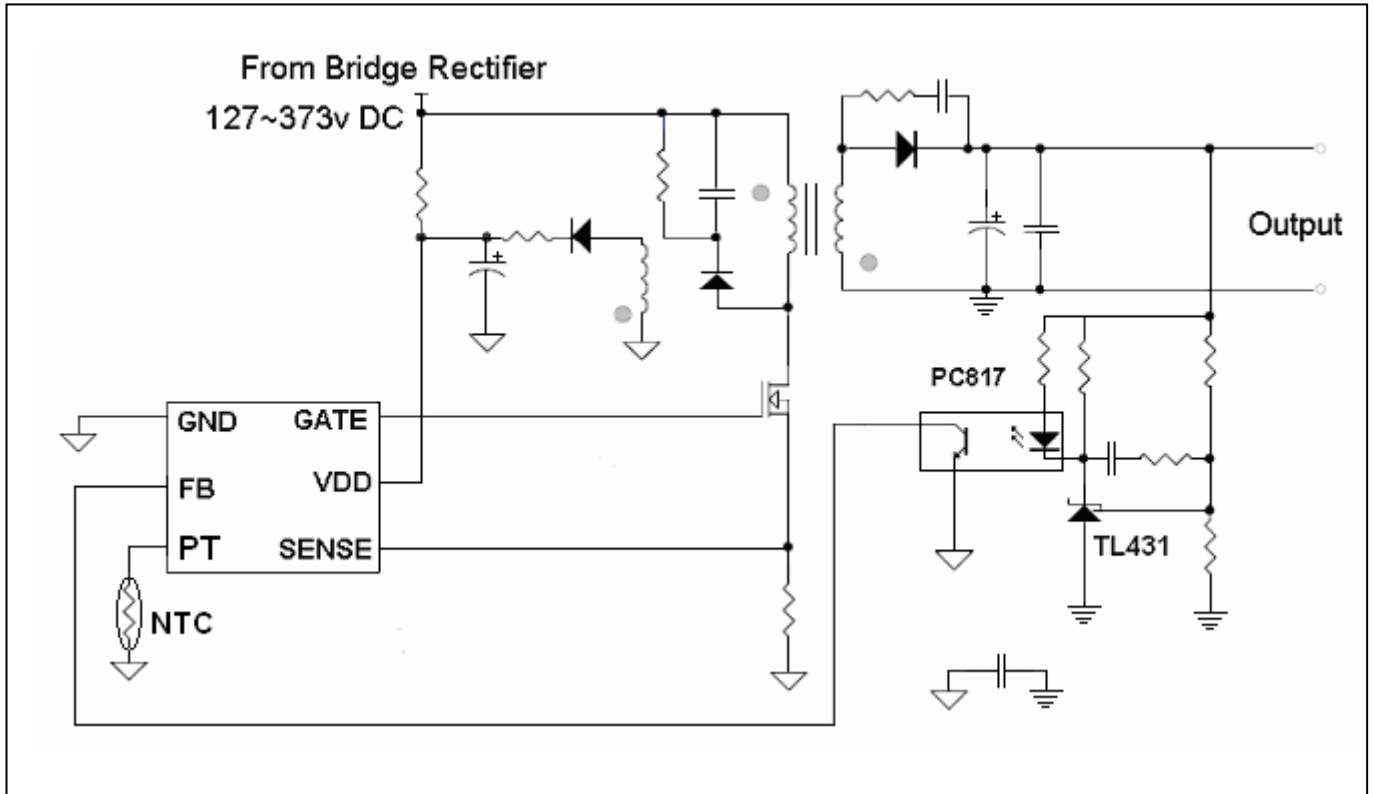

Pin Configuration

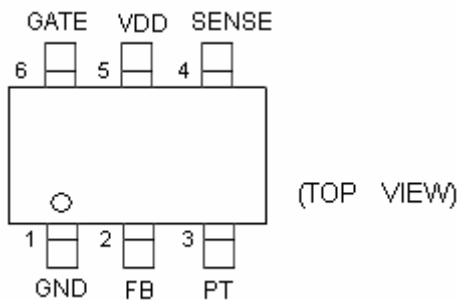

Pin Assignment

Pin Name	Pin Number	Pin Function
GND	1	Ground
FB	2	Feedback input pin. The PWM duty cycle is determined by voltage level into this pin and the current-sense signal at Pin 6.
PT	3	Connected through a NTC resistor to ground for over temperature shutdown/latch control or connected through Zener to VDD for adjustable over voltage protection.
SENSE	4	Current sense input pin. Connected to MOSFET current sensing resistor node.
VDD	5	Chip DC power supply pin.
GATE	6	Totem-pole gate drive output for the power MOSFET.

Function Block Diagram

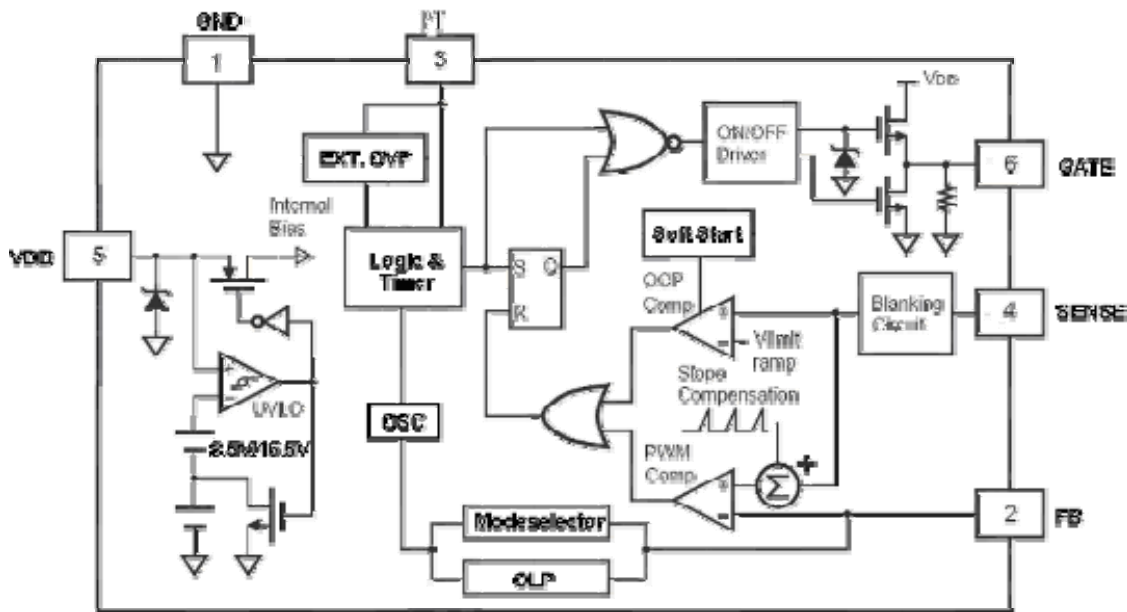

Absolute Maximum Ratings

Parameter	Value	Unit
V _{DD} to GND	+29	V
V _{DD} clamped current	10	mA
V _{DD} clamped voltage	32	V
V _{FB} , V _{SENSE} and V _{RI} to GND	-0.3~+7	V
Maximum Junction Temperature (T _J MAX)	-20 ~ +150	°C
Storage Temperature Range	-55 ~ +160	°C

Note : Stresses beyond those listed under "Absolute Maximum Ratings" may cause permanent damage to the device.

Recommended Operating Conditions

- Supply Voltage, V_{DD}.....+10V to +30V
- Operating Temperature Range.....-20 °C to +85 °C
- Power Dissipation (R_{θJA}=250 °C/W) @25 °C, FR-4 PCB , 2oz.....0.4W

ESD Information

- Human Body Mode.....2000V
- Machine Mode.....200V



Electrical Characteristics

(TA = 25°C, VDD=16V if not otherwise noted)

Parameter	Symbol	Test Conditions	Min	Typ	Max	Units
SUPPLY SECTION						
Chip start up current via VDD pin	I_set	Vdd=12V, measure current into VDD pin		3	20	uA
Operation current	I_op	VDD=16V,VFB=3V		1.4		mA
VDD UVLO enter	UVLO_L		7.5	8.5	9.5	V
VDD UVLO exit	UVLO_H		14.5	15.5	16.5	V
VDD OVP	VDD_OVP		30	32	34	V
VZ(VDD clamp voltage)	VDD_CLP	Iz(Idd)=10mA	30	32	34	V
FEEDBACK SECTION						
PWM input gain	A_PWM	ΔVFB/ΔVCS		2		V/V
VFB open loop voltage	VFB_O			4.2		V
FB pin short circuit current	VFB_S	Short FB pin to gnd and measure current		0.35		mA
Burst mode on threshold	V_BM_on			0.675		V
Burst mode off threshold	V_BM_off			0.575		V
Power limiting FB threshold	VFB_th_P			3.7		V
Power limiting delay time	T_PL_D			88		ms
Input impedance	R_FB			16		KΩ
OSCILLATOR						
Soft start time	T_ss			4		ms
Burst mode switching frequency	F_burst			22		kHz
Normal operation frequency	F_nor		60	65	70	kHz
Frequency modulation range	F_d_jit			±4		%
Jitter frequency	F_jitter			32		Hz
Frequency temperature stability	F_d_tem			4		kHz
CURRENT SENSE SECTION						
Leading edge blanking time	T_blank			220		nS
Sense pin input impedance	R_sense			40		kΩ
Over current threshold voltage at zero duty cycle	VTH_OC_0	FB=3.3V	0.72	0.75	0.78	V
Over current threshold voltage at max. switching on time	VTH_OC_1	FB=3.3V		0.9		V
Over current protect delay	T_OC_D	CS>VTH_OC, FB=3.3V, CL=1nF @Gate		120		nS
GATE OUTPUT						
Output low level	VOL	I _o =20mA			1	V
Output high level	VOH	I _o =20mA	6			V
Output voltage clamped level	VO_clamp			12		V
Output rising time	Tr	Cl=1nf		175		nS
Output falling time	Tf	Cl=1nf		85		ns
PT Pin						
PT pin source current	I_PT		95	100	105	μA
Thresh hold of OTP	V_OTP		0.95	1	1.05	V



OTP debounce time	T_OTP			6		cycle
External OVP trigger point	Vth_OVP			4		V
Float voltage at PT pin	V_PT_FL			2.3		V

Typical Characteristics (TA = 25°C, VDD=16V if not otherwise noted.)

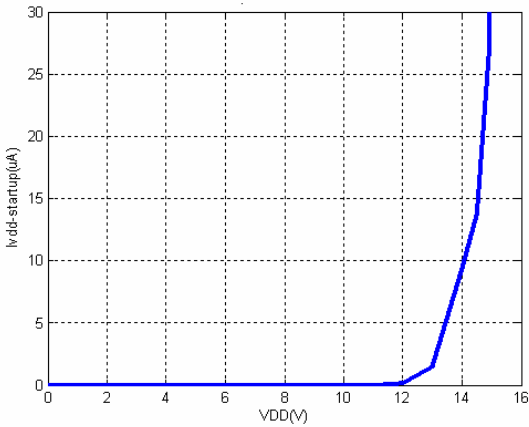

Start Current Vs VDD Voltage

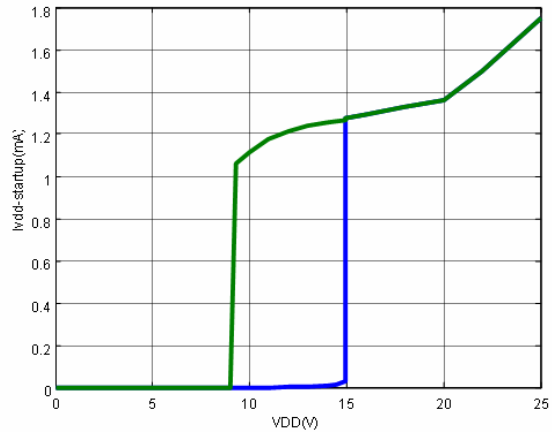

UVLO Voltage & Operation Current

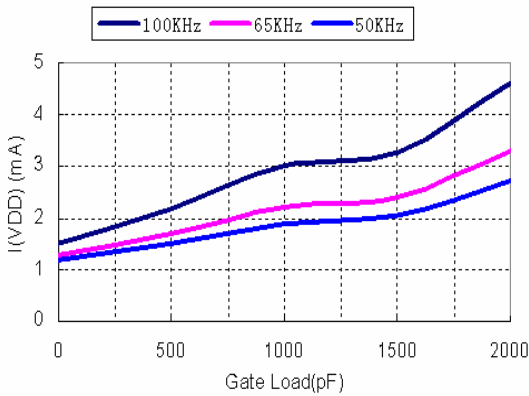

Operation Current VS Load

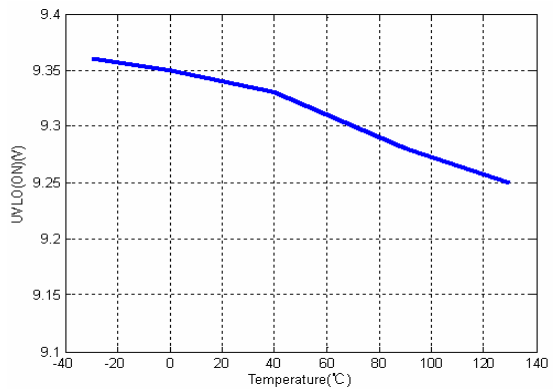

UVLO (On) Voltage VS Temp

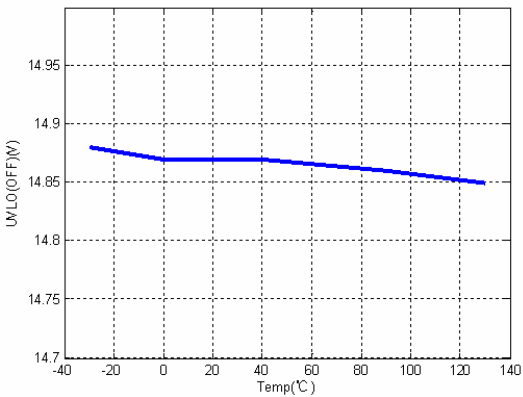

UVLO (Off) Voltage VS Temp

OPERATION DESCRIPTION

Over-view description

The MC7773N6 includes all necessary function to build an easy and cost effective solution for low power supplies to meet the international power conservation requirements.

Start-up current

Startup current of MC7773N6 is designed to be very low so that VDD could be charged up above UVLO (exit) threshold level and device starts up quickly. Also a large value startup resistor can be used to minimize the power loss.

Green Mode Operation (Patent)

At light load or no load condition, the switch loss become the major loss of the power supply, to reduce the power wasted in light and no load condition, based on a special designed voltage controlled oscillator, green mode operation of the power supply can be achieved by using MC7773N6. The controller will judge the load condition based on the voltage of FB pin. In light load the FB voltage will decrease, when VFB is lower than a set threshold voltage, a FB depending time (TR2) will be generated by the oscillator and decrease the operating frequency of the power supply, the minimum frequency is set about 22kHz. The function block and the working waveform can be depicted as below:

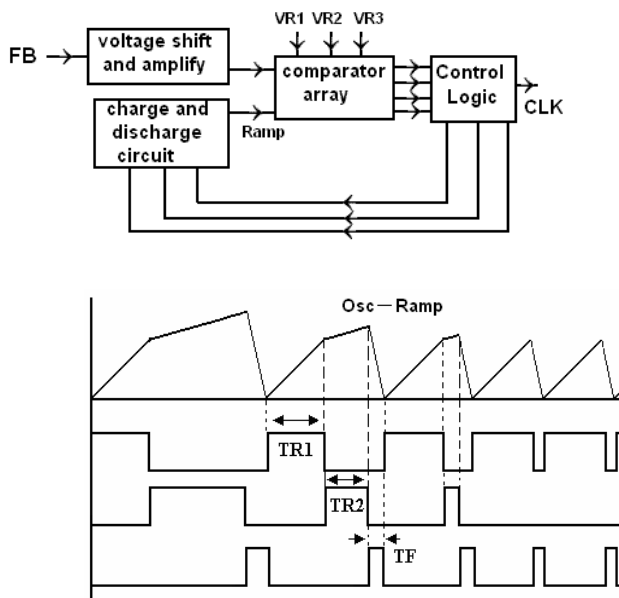

When V_{FB} decreases further, the power supply will enter into burst mode operation to decrease the power consumed at no load condition. Besides there is no audible noise in any load condition.

Built-in Slope Compensation and Frequency Shuffling

While MC7773N6 works in CCM mode, slope compensation and frequency shuffling is activated. The sensed voltage across the sense resistor is used for pwm control, and pulse by pulse current limit, Built-in slope compensation circuit adds a voltage ramp onto the current sense input voltage. This greatly improves the close loop stability and prevents the sub-harmonic oscillation of peak current mode pwm control scheme.

To improve the EMI performance, the frequency of CCM mode is shuffling to $65\text{kHz} \pm 4\%$.

Line Slope Compensation

Adjusting the RSENSE can set the Max output power of the power supple mode. The current flowing by the power MOSFET has an extra value due to the system delay T that the current detected from the sense pin to power MOSFET cut off in the MC7773N6. To guarantee the output power is a constant for universal input AC voltage, there is a positive ramp signal to compensate the system delay T and the line input. At lower line-input voltage the higher OCP threshold will bring constant power OCP as below.

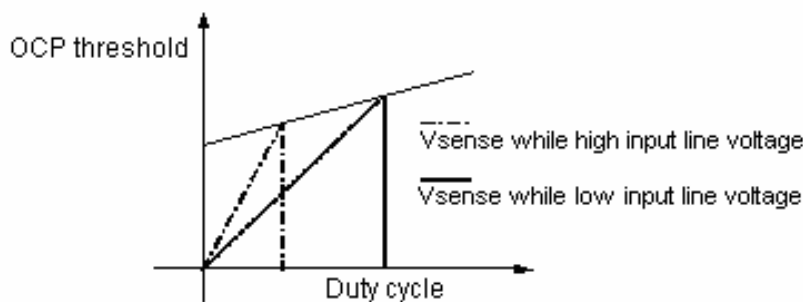

Leading Edge Blanking

Each time when the power MOSFET is switched on, a turn-on spike will inevitably occur on the sense-resistor. To avoid premature termination of the switching pulse, a 300 nsec leading-edge blanking time is built in. Conventional RC filtering can therefore be omitted. During this blanking period, the current-limit comparator is disabled and it cannot switch off the gate driver.

Gate Driver

The output stage of MC7773N6 is a fast totem pole gate driver. Cross conduction has been avoided to minimize heat dissipation, increases efficiency and enhances reliability. The output driver is clamped by an internal 18V Zener diode in order to protect power MOSFET transistors against undesirable gate over voltage. A soft driving waveform is implemented to minimize EMI.

Protect Functions

To increase the reliability of power supply system many protection functions is integrated in this controller, including Cycle-by-Cycle current limiting (OCP), Over Load Protection (OLP), Over Temperature Protection(OTP), External Over Voltage Protection (OVP) and over voltage clamp, Under Voltage Lockout on VDD (UVLO). At overload condition when FB input voltage exceeds power limit threshold value for more than TD_PL (power limit debounce time), the controller reacts to shut down the output power MOSFET. Device restarts when VDD voltage drops below UVLO limit. VDD is supplied by transformer auxiliary winding output. It is clamped when VDD is higher than threshold value. The power MOSFET is shut down when VDD drops below UVLO limit and device enters power on start-up sequence thereafter. Pin floating protection for CS, FB, PT is also added. While one of this happens, the GATE is turned off.

PT Pin Typical Application Circuit

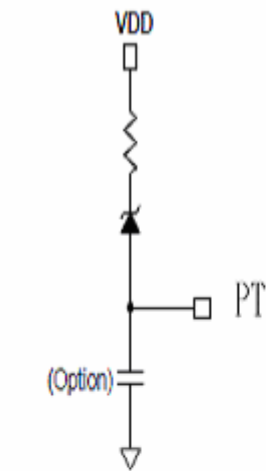

$V_{DD} OVP : V_{DD} > V_R + V_Z + 4V$
 VDD OVP Only

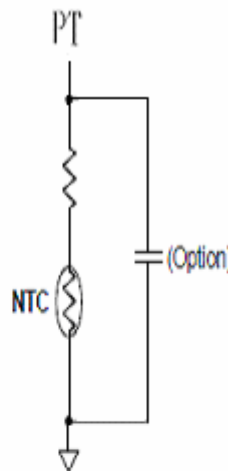

OTP Only

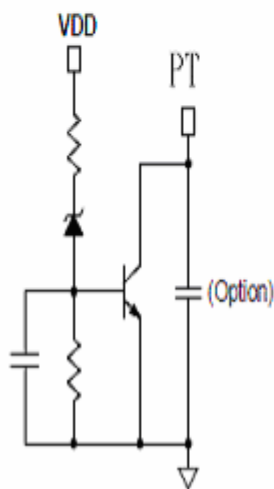

VDD OVP

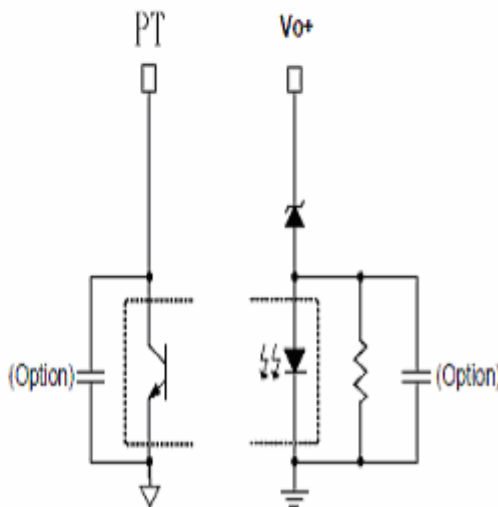

$V_{OUT} OVP$

Reel Dimension

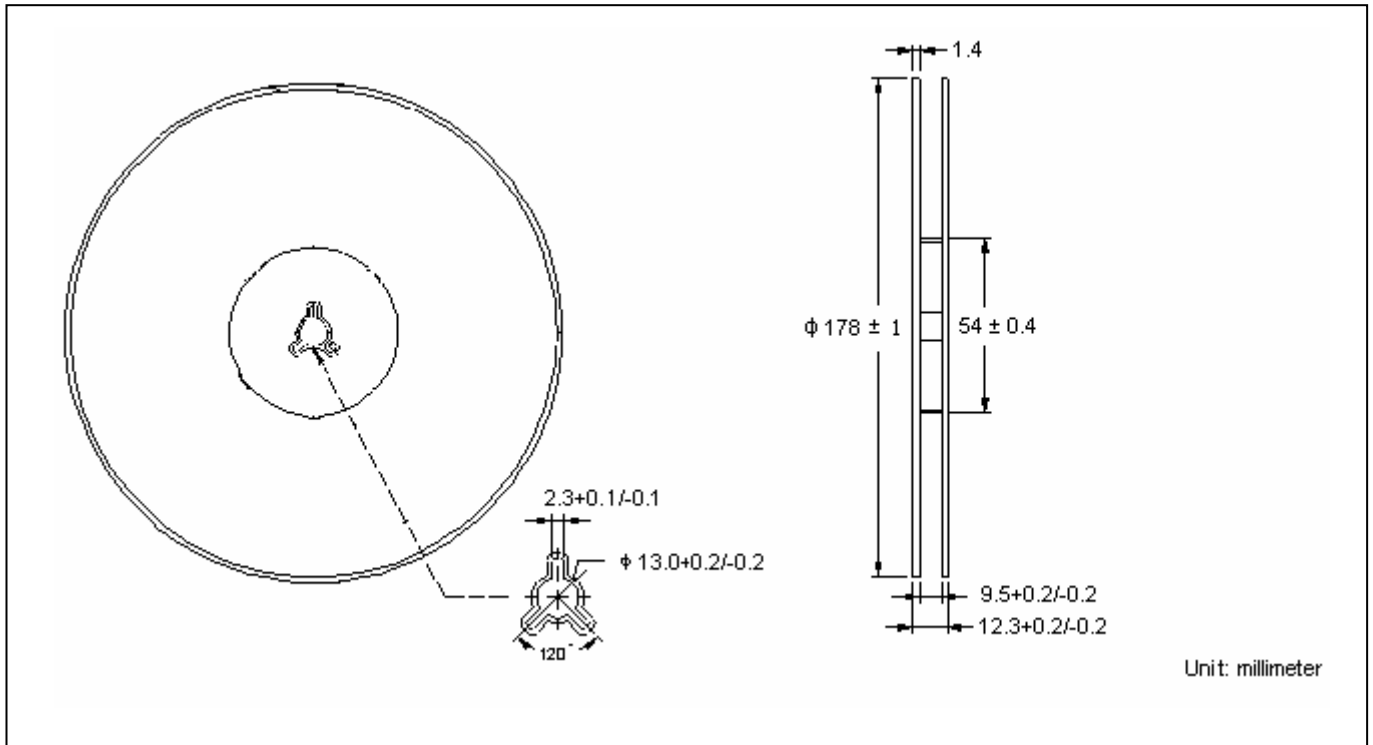

Carrier Tape Dimension

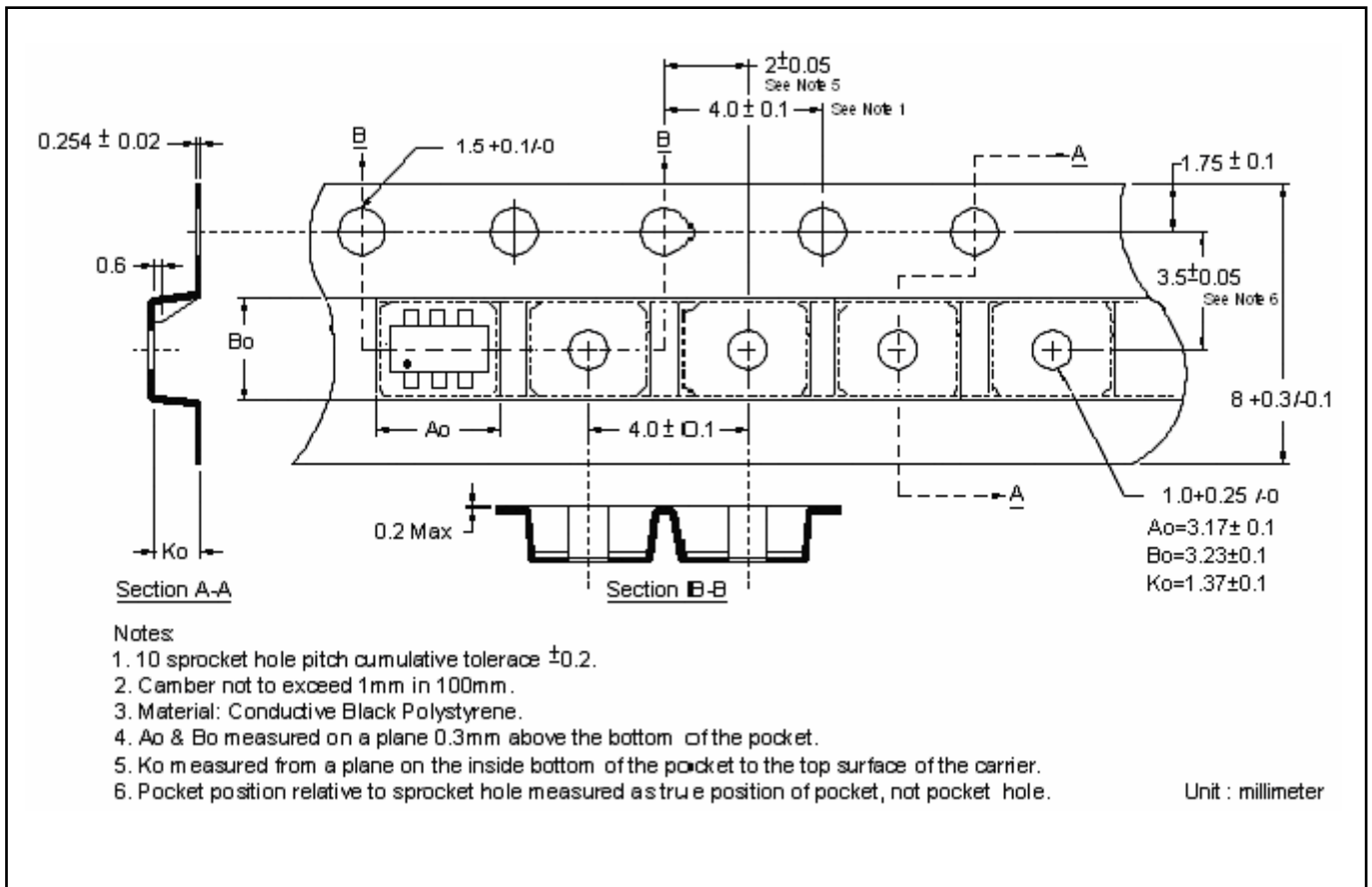

Recommended wave soldering condition

Product	Peak Temperature	Soldering Time
Pb-free devices	260 +0/-5 °C	5 +1/-1 seconds

Recommended temperature profile for IR reflow

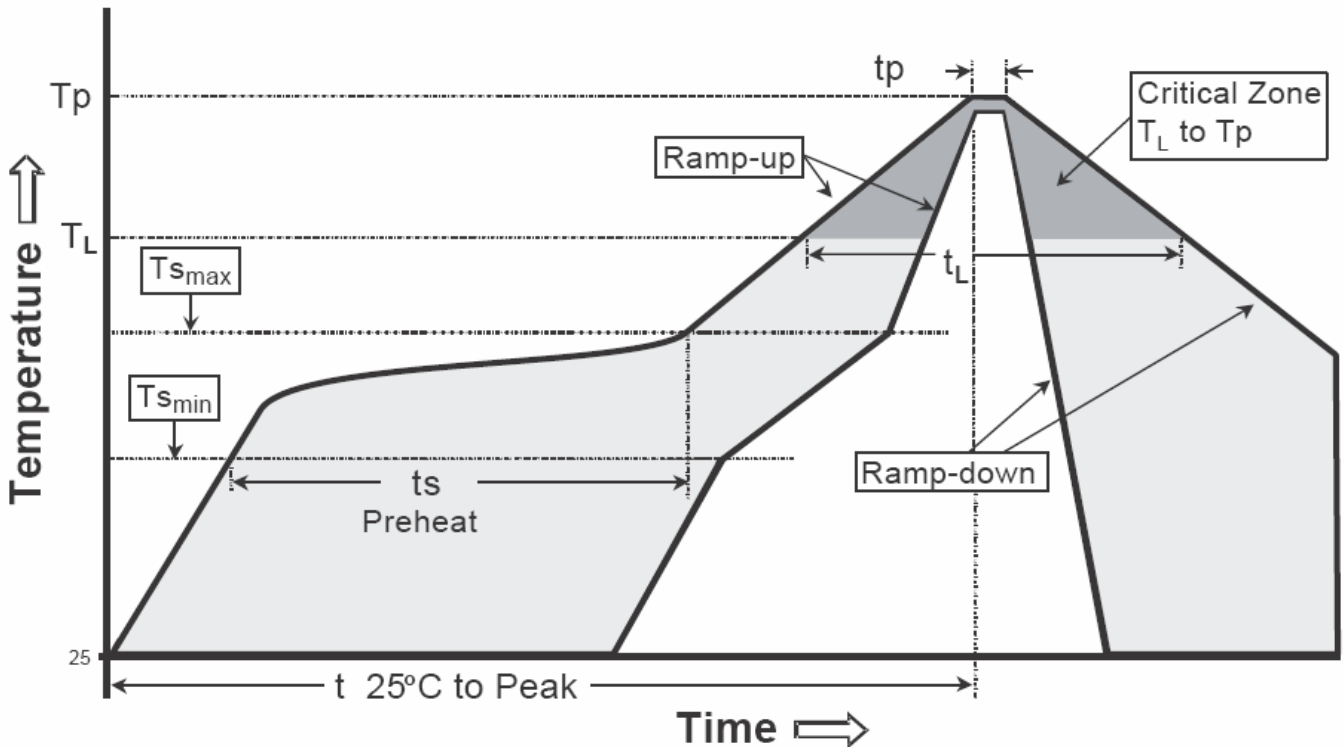

Profile feature	Sn-Pb eutectic Assembly	Pb-free Assembly
Average ramp-up rate (T _{smax} to T _p)	3°C/second max.	3°C/second max.
Preheat		
-Temperature Min(T _{s min})	100°C	150°C
-Temperature Max(T _{s max})	150°C	200°C
-Time(t _{s min} to t _{s max})	60-120 seconds	60-180 seconds
Time maintained above:		
-Temperature (T _L)	183°C	217°C
- Time (t _L)	60-150 seconds	60-150 seconds
Peak Temperature(T _P)	240 +0/-5 °C	260 +0/-5 °C
Time within 5°C of actual peak temperature(tp)	10-30 seconds	20-40 seconds
Ramp down rate	6°C/second max.	6°C/second max.
Time 25 °C to peak temperature	6 minutes max.	8 minutes max.

Note : All temperatures refer to topside of the package, measured on the package body surface.

SOT-23-6L Dimension

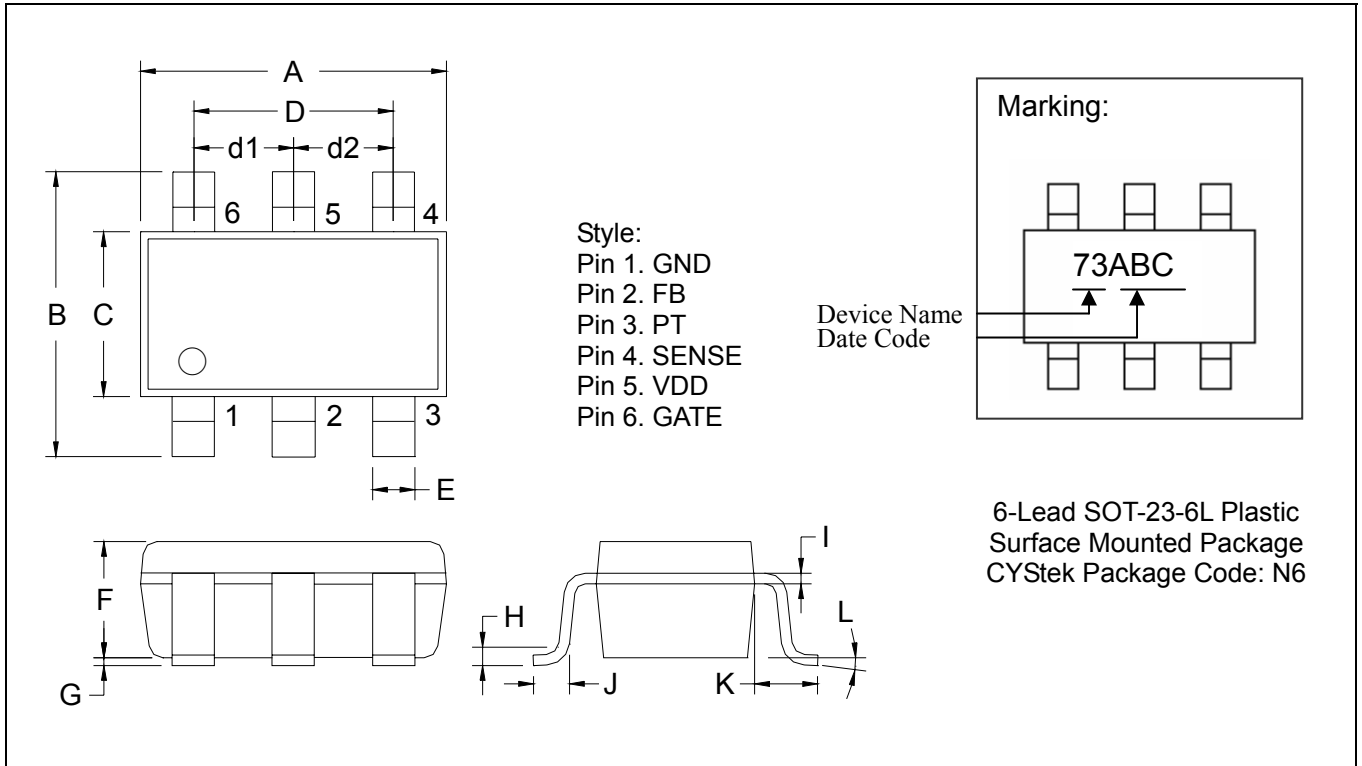

DIM	Inches		Millimeters		DIM	Inches		Millimeters	
	Min.	Max.	Min.	Max.		Min.	Max.	Min.	Max.
A	0.1063	0.1220	2.70	3.10	F	0.0472 REF		1.20 REF	
B	0.1024	0.1181	2.60	3.00	G	0	0.0059	0	0.15
C	0.0551	0.0709	1.40	1.80	H	-	0.0086	-	0.22
D	0.0748 REF		1.90 REF		I	0.0047 REF		0.12 REF	
d1	0.0374 REF		0.95 REF		J	0.0146 REF		0.37 REF	
d2	0.0374 REF		0.95 REF		K	0.0236 REF		0.60 REF	
E	0.0118	0.0217	0.30	0.55	L	0°	10°	0°	10°

Notes : 1.Controlling dimension : millimeters.
 2.Maximum lead thickness includes lead finish thickness, and minimum lead thickness is the minimum thickness of base material.
 3.If there is any question with packing specification or packing method, please contact your local CYStek sales office.

Material :

- Mold Compound : Epoxy resin family, flammability solid burning class:UL94V-0.

Important Notice:

- All rights are reserved. Reproduction in whole or in part is prohibited without the prior written approval of CYStek.
- CYStek reserves the right to make changes to its products without notice.
- CYStek **semiconductor products are not warranted to be suitable for use in Life-Support Applications, or systems.**
- CYStek assumes no liability for any consequence of customer product design, infringement of patents, or application assistance.