

## High voltage ignition coil driver power integrated circuit

### Features

Type	V <sub>cl</sub>	I <sub>cl</sub>	I <sub>cc</sub>
VB525SP-E	380 V	10 A	150 mA

- ECOPACK<sup>®</sup>: lead free and RoHS compliant
- Primary coil voltage internally set
- Coil current limit internally set
- Logic level compatible input
- Driving current quasi proportional to collector current
- Single flag on coil current
- Low voltage clamp thermal shutdown

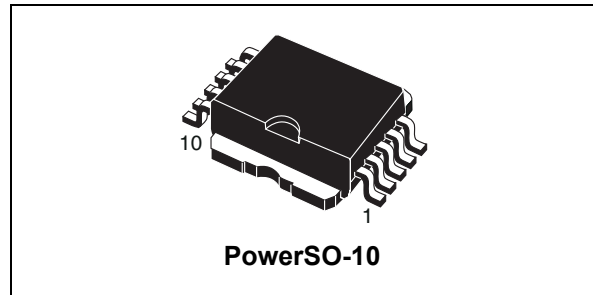

### Description

The VB525SP-E is a high voltage power integrated circuit made using the STMicroelectronics™ VIPower™ M1-3 technology, with Darlington and logic level compatible vertical current flow power driving circuit.

The enable pin allows to externally block the switch when the input is on. A built-in protection circuit for coil current limiting and collector voltage clamping allows the device to be used as a smart, high voltage, high current interface in advanced electronic ignition systems. If the input signal from the microcontroller happens to remain high, the device protects itself against overheating by forcing collector current to smoothly decrease (low voltage clamp feature) to avoid undesired spark.

**Table 1. Device summary**

Package	Order codes	
	Tube	Tape and reel
PowerSO-10	VB525SP-E	VB525SPTR-E

# Contents

- 1      Block diagram and pin description ..... 5**
- 2      Electrical specifications ..... 7**
  - 2.1    Absolute maximum rating ..... 7
  - 2.2    Thermal data ..... 8
- 3      Electrical characteristics ..... 9**
  - 3.1    Electrical characteristics curves ..... 12
- 4      Application schematic ..... 13**
  - 4.1    Principle of operation ..... 13
  - 4.2    Feedback ..... 13
  - 4.3    Overvoltage ..... 14
- 5      Package information ..... 15**
  - 5.1    ECOPACK® packages ..... 15
  - 5.2    PowerSO-10 mechanical data ..... 15
  - 5.3    Packing information ..... 17
- 6      Revision history ..... 18**

## List of tables

Table 1.	Device summary . . . . .	1
Table 2.	Pin function . . . . .	5
Table 3.	Absolute maximum ratings . . . . .	7
Table 4.	Thermal data . . . . .	8
Table 5.	Electrical characteristics . . . . .	9
Table 6.	PowerSO-10 mechanical data . . . . .	16
Table 7.	Document revision history . . . . .	18

# List of figures

Figure 1. Block diagram . . . . . 5  
Figure 2. Connection diagram (top view) . . . . . 6  
Figure 3. Switching time for inductive load . . . . . 11  
Figure 4. Flag current vs temperature . . . . . 12  
Figure 5. Single pulse avalanche energy capability . . . . . 12  
Figure 6. Self clamped inductive switching current vs time . . . . . 12  
Figure 7. Low voltage clamp feature . . . . . 12  
Figure 8. Application diagram . . . . . 13  
Figure 9. PowerSO-10 package dimensions . . . . . 15  
Figure 10. PowerSO-10 suggested pad layout and tube shipment (no suffix). . . . . 17  
Figure 11. PowerSO-10 tape and reel shipment (suffix "TR") . . . . . 17

# 1 Block diagram and pin description

Figure 1. Block diagram

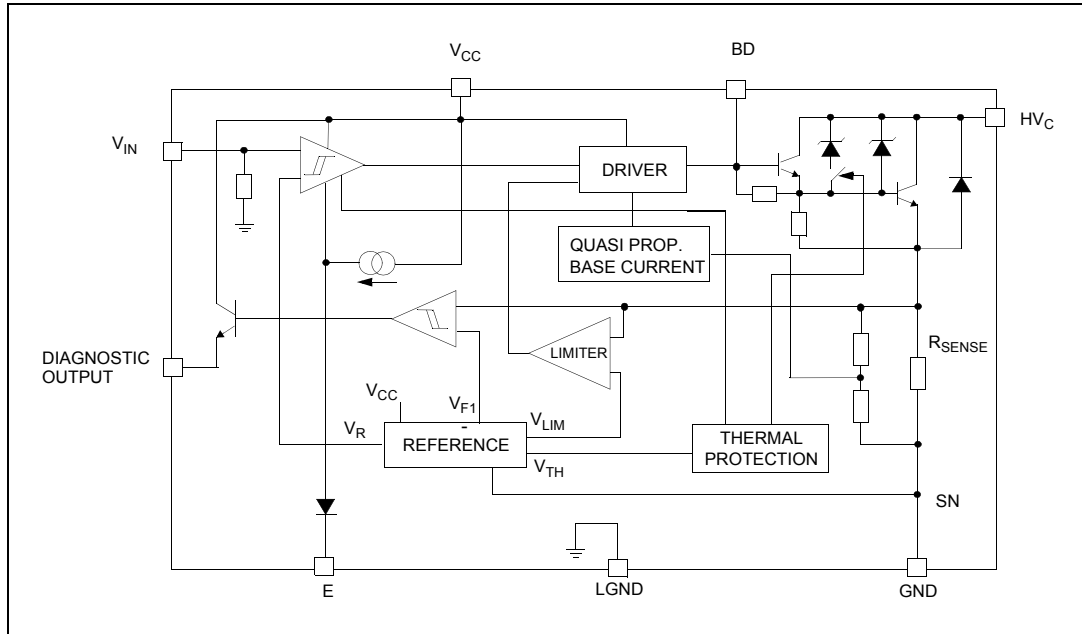
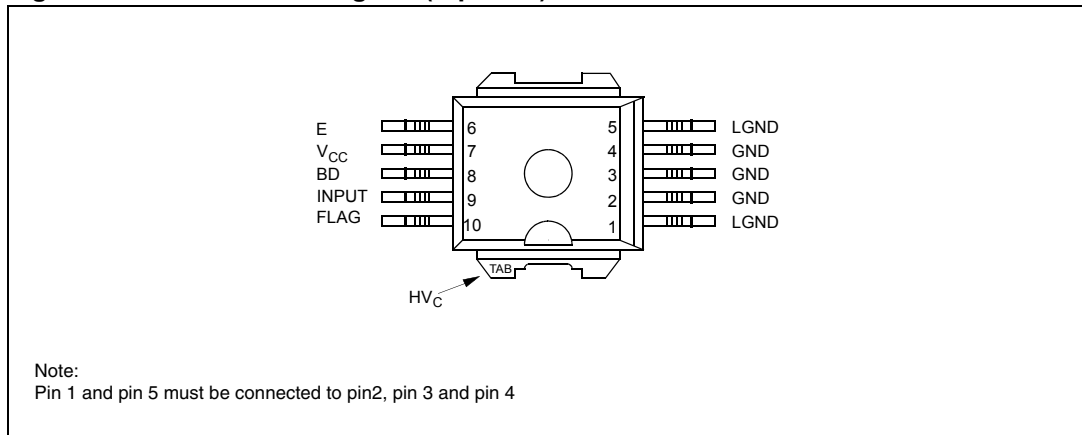

Table 2. Pin function

Pin number	Name	Function
1, 5	LGND	Signal ground
2, 3, 4	GND	Emitter power ground
6	E	Enable <sup>(1)</sup>
7	V <sub>CC</sub>	Logic supply voltage
8	BD	Base darlington
9	INPUT	Logic input channel (internal pull down)
10	FLAG	Diagnostic output signal (open emitter)
Tab	HV <sub>C</sub>	Primary coil output driver (open collector)

1. When grounded the input is enabled

Figure 2. Connection diagram (top view)



## 2 Electrical specifications

### 2.1 Absolute maximum rating

Stressing the device above the ratings listed in the “Absolute maximum ratings” tables may cause permanent damage to the device. These are stress ratings only and operation of the device at these or any other conditions above those indicated in the Operating sections of this specification is not implied. Exposure to the conditions in this section for extended periods may affect device reliability. Refer also to the STMicroelectronics SURE Program and other relevant quality documents.

**Table 3. Absolute maximum ratings**

Symbol	Parameter	Value	Unit
$HV_c$	Collector voltage (internally limited)	-0.3 to $V_{clamp}$	V
$I_C$	Collector current (internally limited)	10	A
$I_{C(gnd)}$	DC current on emitter power	$\pm 10.5$	A
$V_{CC}$	Driving stage supply voltage	-0.3 to 7	V
$I_s$	Driving circuitry supply current	$\pm 200$	mA
$I_{s(gnd)}$	DC current on ground pin	$\pm 1$	A
$V_{IN}$	Input voltage	-0.3 to $V_{CC} + 0.3$	V
$I_{IN}$	Maximum input current	100	mA
$f_{IN}$	Logic input frequency in operative mode	DC to 150	Hz
$V_{OUT(flag)}$	Output voltage primary threshold current level	-0.3 to $V_{CC} + 0.3$	V
$I_{OUT(flag)}$	Flag output current	100	mA
$P_{max}$	Power Dissipation ( $T_c = 25\text{ }^\circ\text{C}$ )	125	W
$E_{s/b}$	Self clamped energy during output power clamping (see <a href="#">Figure 5</a> )	275	mJ
$V_{ESD}$	ESD voltage ( $HV_c$ pin)	$\pm 4$	KV
$V_{ESD}$	ESD voltage (enable pin)	+1.5; -2	KV
$V_{ESD}$	ESD voltage (other pins)	$\pm 2$	KV
$I_{BD}$	Input darlington base current	150	mA
$V_{BD}$	Input darlington base voltage	Internally limited	V
$T_j$	Operating junction temperature	-40 to 150	$^\circ\text{C}$
$T_{stg}$	Storage temperature range	-55 to 150	$^\circ\text{C}$
$V_E$	Maximum enable voltage	-0.3 to 5.5	V
$I_E$	Maximum enable current	$\pm 150$	$\mu\text{A}$

## 2.2 Thermal data

**Table 4. Thermal data**

Symbol	Parameter	Value	Unit
$R_{thj-case}$	Thermal resistance junction-case (max)	1	°C/W
$R_{thj-amb}$	Thermal resistance junction-ambient (max)	51	°C/W



### 3 Electrical characteristics

5.3 V < V<sub>bat</sub> < 24 V; V<sub>CC</sub> = 5 V ± 10 %; -40 °C < T<sub>j</sub> < 125 °C; R<sub>coil</sub> = 580 mΩ; L<sub>coil</sub> = 3.75 mH unless otherwise specified<sup>(a)</sup>.

**Table 5. Electrical characteristics**

Symbol	Parameter	Test conditions	Min	Typ	Max	Unit
V <sub>cl</sub>	High voltage clamp	I <sub>coil</sub> = 6.5 A	320	380	420	V
V <sub>lcl</sub>	Low voltage clamp	I <sub>coil</sub> = 6.5 A; T <sub>j</sub> = T <sub>sd</sub>	30	40	50	V
V <sub>ce(sat)</sub>	Power stage saturation voltage	I <sub>C</sub> = 6 A; V <sub>IN</sub> = 4 V		1.5	2	V
I <sub>CC(stdby)</sub>	Standby supply current	IN = Off			11	mA
I <sub>CC</sub>	DC logic current	V <sub>b</sub> = 16 V; I <sub>C</sub> = 6.5 A; f = 100 Hz; Load = Coil; V <sub>CC</sub> = 5.5 V			40	mA
I <sub>CC(peak)</sub>	Peak DC logic current during on phase	I <sub>C</sub> = 6.5 A		100	150	mA
V <sub>CC</sub>	DC logic voltage		4.5		5.5	V
I <sub>cl</sub>	Coil current limit	-40 °C < T <sub>j</sub> < 125 °C <sup>(1)</sup>	9		11	A
I <sub>c(off)</sub>	Output off-state current	IN = Off; V <sub>HVC</sub> = 24 V; V <sub>CC</sub> = 5 V; T <sub>j</sub> = 25 °C			5	mA
V <sub>INH</sub>	High level input voltage	V <sub>CC</sub> = 4.5 V	4		V <sub>CC</sub>	V
V <sub>INL</sub>	Low level input voltage	V <sub>CC</sub> = 5.5 V	-0.3		0.8	V
V <sub>IN(hyst)</sub>	Input threshold hysteresis		0.4			V
I <sub>INH</sub>	High level input current	V <sub>IN</sub> = 4 V			100	μA
I <sub>INL</sub>	Low level input current	V <sub>IN</sub> = 0.8 V	0		30	μA
I <sub>INpd</sub>	Input active pull down	V <sub>IN</sub> = 4 V	10		100	μA
V <sub>diagH</sub>	High level flag output voltage	R <sub>EXT</sub> = 22 KΩ; C <sub>EXT</sub> = 1 nF <sup>(2)</sup>	V <sub>CC</sub> - 1		V <sub>CC</sub>	V
V <sub>diagL</sub>	Low level flag output voltage	R <sub>EXT</sub> = 22 KΩ; C <sub>EXT</sub> = 1 nF <sup>(2)</sup>			0.5	V
I <sub>diagTH</sub>	Coil current level threshold	T <sub>j</sub> = 25 °C	4.25	4.5	4.75	A
I <sub>diagTD</sub>	Coil current level threshold drift	(See <a href="#">Figure 4</a> )				

a. Parametric degradation are allowed with 5.3 V < V<sub>b</sub> < 10 V and V<sub>b</sub> > 24 V.

Table 5. Electrical characteristics (continued)

Symbol	Parameter	Test conditions	Min	Typ	Max	Unit
$I_{\text{diag}}$	High level flag output current	$I_C > I_{\text{diagTH}}$ ; $V_{\text{diag}} = 3 \text{ V}$	0.5			mA
$I_{\text{diag(leak)}}$	Leakage current on flag output	$V_{\text{IN}} = \text{Low}$ ; $V_{\text{CC}} = 5.5 \text{ V}$			10	$\mu\text{A}$
$V_F$	Anti parallel diode forward voltage	$I_C = -1 \text{ A}$			2	V
$E_{\text{s/b}}$	Single pulse avalanche energy	$L = 6 \text{ mH}$ ; $I_C = 8 \text{ A}$		180		mJ
$t_{\text{ON}}$	Turn-on time	$R_C = 0.5 \Omega$ ; $L_C = 3.75 \text{ mH}$ ; $T_j = 25 \text{ }^\circ\text{C}$ ; $V_{\text{bat}} = 13 \text{ V}$ (see <a href="#">Figure 3</a> )		1	5	$\mu\text{s}$
$t_{\text{OFF}}$	Turn-off time	$R_C = 0.5 \Omega$ ; $L_C = 3.75 \text{ mH}$ ; $I_C = 6.5 \text{ A}$ ; $T_j = 25 \text{ }^\circ\text{C}$ ; $V_{\text{bat}} = 13 \text{ V}$ (see <a href="#">Figure 3</a> )		15	25	$\mu\text{s}$
$T_{\text{sd}}$	Thermal shutdown intervention		150			$^\circ\text{C}$
$V_{\text{EH}}$	High level enable voltage	$V_{\text{IN}} = V_{\text{INH}}$ ; $\text{OUT} = \text{Off}^{(3)}$	2			V
$V_{\text{EL}}$	Low level enable voltage	$V_{\text{OUT}}$ free to follow $V_{\text{IN}}$			0.40	V
$I_{\text{EH}}$	High level enable current	$V_E = 5 \text{ V}$			500	$\mu\text{A}$
$I_{\text{EL}}$	Low level enable current	$V_E < 0.4 \text{ V}$	-200			$\mu\text{A}$
$V_{\text{BD(off)}}$	Base darlington voltage off	$V_E = V_{\text{EH}}$			1	V
$V_{\text{BD(on)}}$	Base darlington voltage on	$V_{\text{IN}} = V_{\text{INH}}$ ; $V_E = V_{\text{EL}}$ ; $I_C = 6.5 \text{ A}$	1.8			V

1. The primary coil current value  $I_{\text{cl}}$  must be measured ms after desaturation of the power stage.
2. No internal pull-down.
3. If ENABLE pin is floating  $\text{OUT} = \text{Off}$  for every input status.

Figure 3. Switching time for inductive load

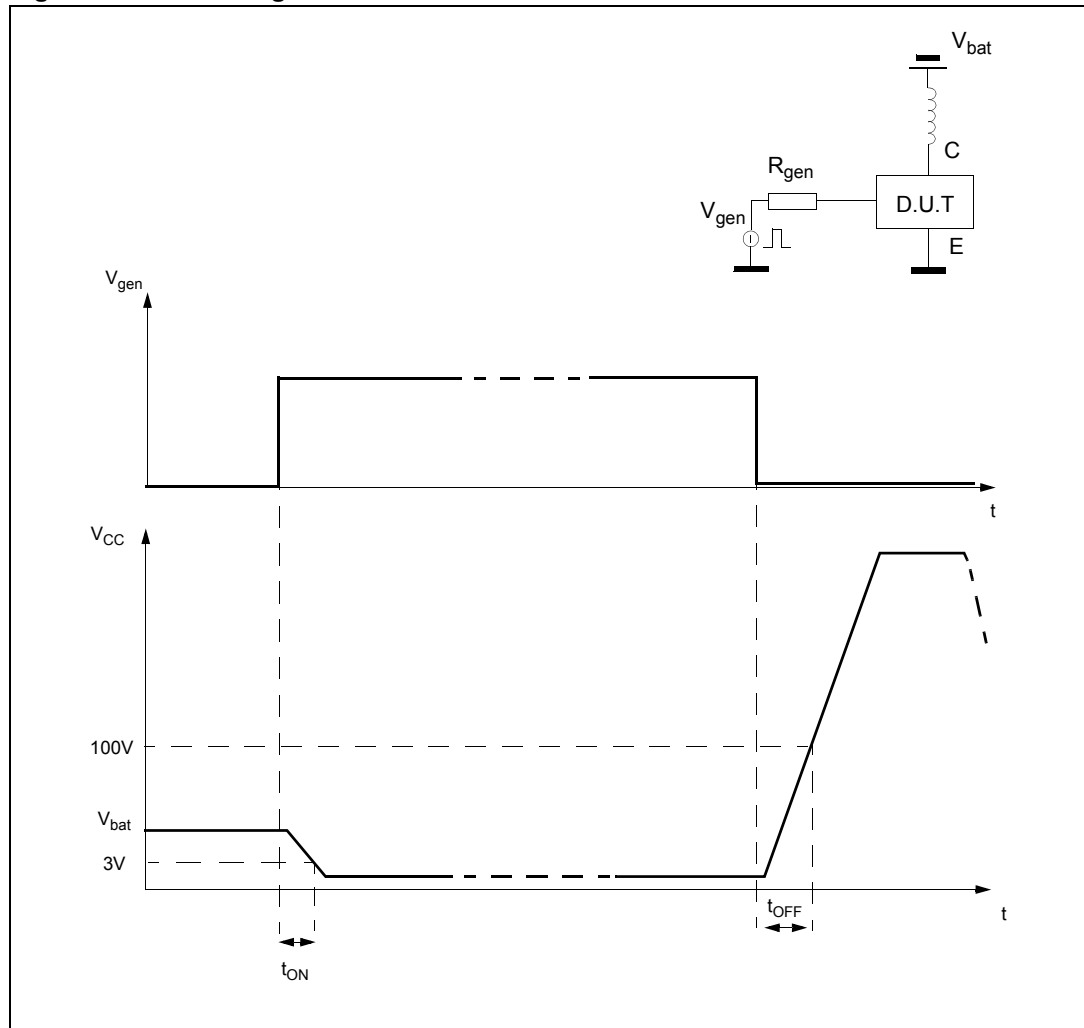

### 3.1 Electrical characteristics curves

Figure 4. Flag current vs temperature

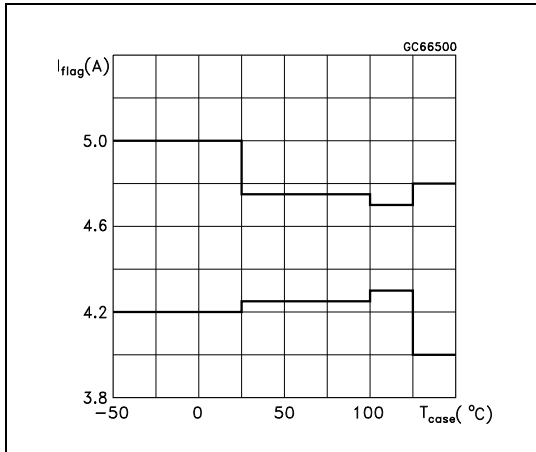

Figure 5. Single pulse avalanche energy capability

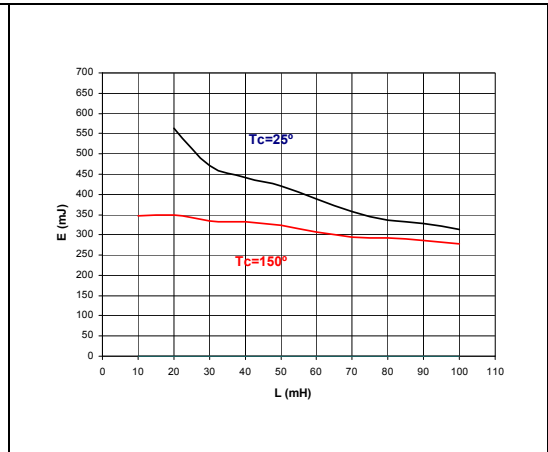

Figure 6. Self clamped inductive switching current vs time

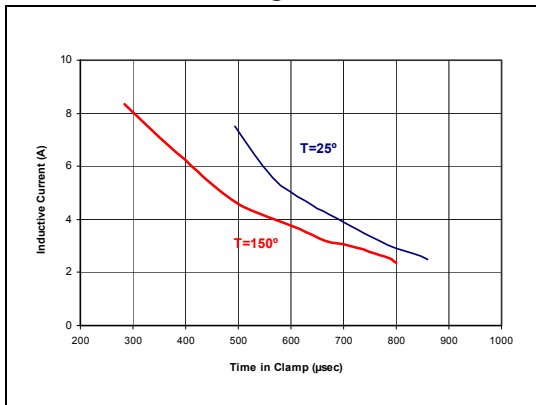
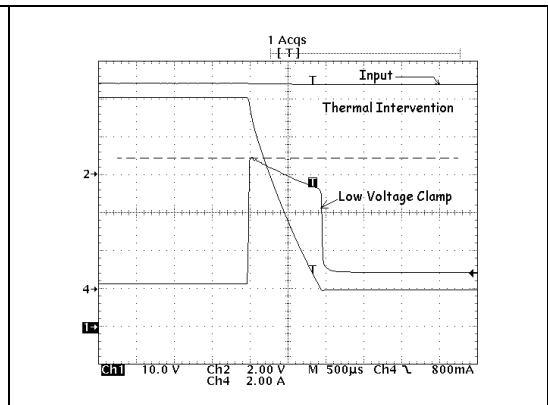
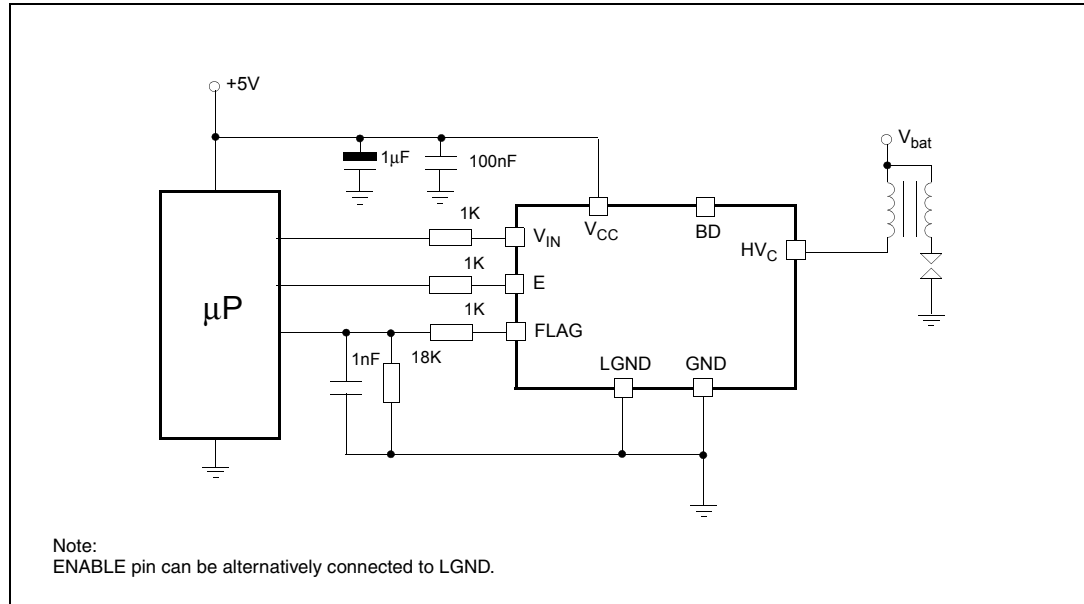

Figure 7. Low voltage clamp feature



## 4 Application schematic

Figure 8. Application diagram



### 4.1 Principle of operation

The VB525SP-E is mainly intended as a high voltage power switch device driven by a logic level input and interfaces directly to a high energy electronic ignition coil.

The input  $V_{IN}$  of the VB525SP-E is fed from a low power signal generated by an external controller that determines both dwell time and ignition point. During  $V_{IN}$  high ( $\geq 4$  V) the VB525SP-E increases current in the coil to the desired, internally set current level.

After reaching this level, the coil current remains constant until the ignition point, that corresponds to the transition of  $V_{IN}$  from high to low (typ. 1.9 V threshold).

During the coil current switch-off, the primary voltage  $HV_C$  is clamped at an internally set value  $V_{CL}$ , typically 380 V. The transition from saturation to desaturation, coil current limiting phase, must have the ability to accommodate an overvoltage.

A maximum overshoot of 20 V is allowed.

### 4.2 Feedback

When the collector current exceeds 4.5 A, the feedback signal is turned high and it remains so, until the input voltage is turned-off.

### 4.3 Overvoltage

The VB525SP-E can withstand the following transients of the battery line:

- -100 V / 2 msec ( $R_i = 10 \Omega$ )
- +100 V / 0.2 msec ( $R_i = 10 \Omega$ )
- +50 V / 400 msec ( $R_i = 4.2 \Omega$ , with  $V_{IN} = 3 \text{ V}$ )

## 5 Package information

### 5.1 ECOPACK® packages

In order to meet environmental requirements, ST offers these devices in different grades of ECOPACK® packages, depending on their level of environmental compliance. ECOPACK® specifications, grade definitions and product status are available at: [www.st.com](http://www.st.com).

ECOPACK® is an ST trademark.

### 5.2 PowerSO-10 mechanical data

Figure 9. PowerSO-10 package dimensions

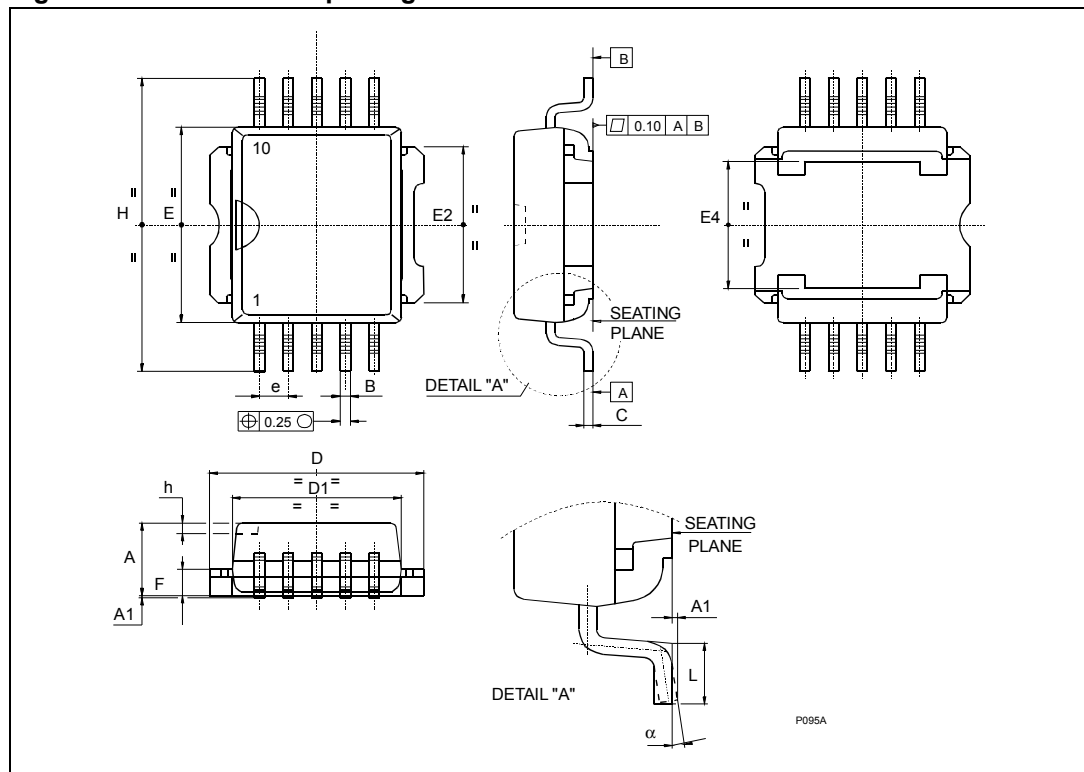

Table 6. PowerSO-10 mechanical data

Symbol	Millimeters		
	Min.	Typ.	Max.
A	3.35		3.65
A <sup>(1)</sup>	3.4		3.6
A1	0.00		0.10
B	0.40		0.60
B <sup>(1)</sup>	0.37		0.53
C	0.35		0.55
C <sup>(1)</sup>	0.23		0.32
D	9.40		9.60
D1 <sup>(2)</sup>	7.40		7.60
E <sup>(2)</sup>	9.30		9.50
E2	7.20		7.60
E2 <sup>(1)</sup>	7.30		7.50
E4	5.90		6.10
E4 <sup>(1)</sup>	5.90		6.30
e		1.27	
F	1.25		1.35
F <sup>(1)</sup>	1.20		1.40
H	13.80		14.40
H <sup>(1)</sup>	13.85		14.35
h		0.50	
L	1.20		1.80
L <sup>(1)</sup>	0.80		1.10
$\alpha$	0°		8°
$\alpha$ <sup>(1)</sup>	2°		8°

1. Muar only POA P013P.

2. Resin protrusion not included (max value: 0.20 mm per side).



### 5.3 Packing information

Figure 10. PowerSO-10 suggested pad layout and tube shipment (no suffix)

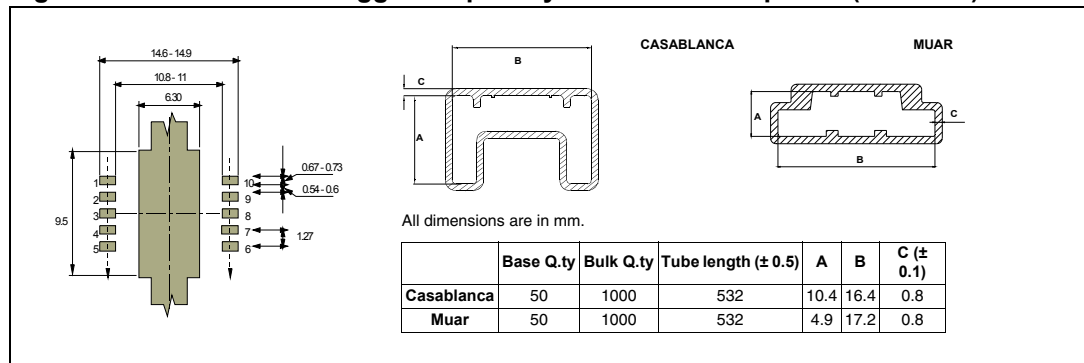
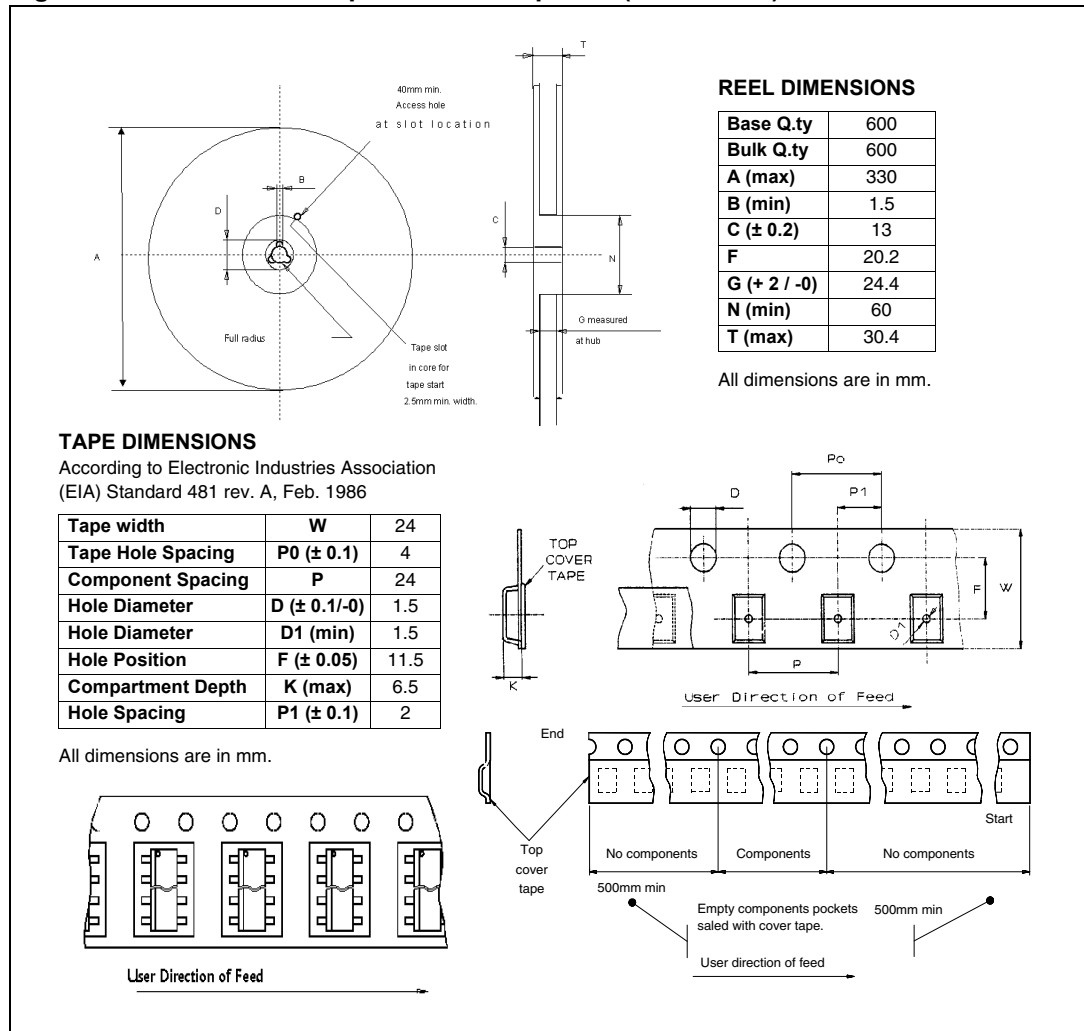

Figure 11. PowerSO-10 tape and reel shipment (suffix “TR”)



## 6 Revision history

**Table 7. Document revision history**

Date	Revision	Changes
27-Sep-2010	1	Initial release.
18-Sep-2013	2	Updated Disclaimer

**Please Read Carefully:**

Information in this document is provided solely in connection with ST products. STMicroelectronics NV and its subsidiaries ("ST") reserve the right to make changes, corrections, modifications or improvements, to this document, and the products and services described herein at any time, without notice.

All ST products are sold pursuant to ST's terms and conditions of sale.

Purchasers are solely responsible for the choice, selection and use of the ST products and services described herein, and ST assumes no liability whatsoever relating to the choice, selection or use of the ST products and services described herein.

No license, express or implied, by estoppel or otherwise, to any intellectual property rights is granted under this document. If any part of this document refers to any third party products or services it shall not be deemed a license grant by ST for the use of such third party products or services, or any intellectual property contained therein or considered as a warranty covering the use in any manner whatsoever of such third party products or services or any intellectual property contained therein.

**UNLESS OTHERWISE SET FORTH IN ST'S TERMS AND CONDITIONS OF SALE ST DISCLAIMS ANY EXPRESS OR IMPLIED WARRANTY WITH RESPECT TO THE USE AND/OR SALE OF ST PRODUCTS INCLUDING WITHOUT LIMITATION IMPLIED WARRANTIES OF MERCHANTABILITY, FITNESS FOR A PARTICULAR PURPOSE (AND THEIR EQUIVALENTS UNDER THE LAWS OF ANY JURISDICTION), OR INFRINGEMENT OF ANY PATENT, COPYRIGHT OR OTHER INTELLECTUAL PROPERTY RIGHT.**

**ST PRODUCTS ARE NOT DESIGNED OR AUTHORIZED FOR USE IN: (A) SAFETY CRITICAL APPLICATIONS SUCH AS LIFE SUPPORTING, ACTIVE IMPLANTED DEVICES OR SYSTEMS WITH PRODUCT FUNCTIONAL SAFETY REQUIREMENTS; (B) AERONAUTIC APPLICATIONS; (C) AUTOMOTIVE APPLICATIONS OR ENVIRONMENTS, AND/OR (D) AEROSPACE APPLICATIONS OR ENVIRONMENTS. WHERE ST PRODUCTS ARE NOT DESIGNED FOR SUCH USE, THE PURCHASER SHALL USE PRODUCTS AT PURCHASER'S SOLE RISK, EVEN IF ST HAS BEEN INFORMED IN WRITING OF SUCH USAGE, UNLESS A PRODUCT IS EXPRESSLY DESIGNATED BY ST AS BEING INTENDED FOR "AUTOMOTIVE, AUTOMOTIVE SAFETY OR MEDICAL" INDUSTRY DOMAINS ACCORDING TO ST PRODUCT DESIGN SPECIFICATIONS. PRODUCTS FORMALLY ESCC, QML OR JAN QUALIFIED ARE DEEMED SUITABLE FOR USE IN AEROSPACE BY THE CORRESPONDING GOVERNMENTAL AGENCY.**

Resale of ST products with provisions different from the statements and/or technical features set forth in this document shall immediately void any warranty granted by ST for the ST product or service described herein and shall not create or extend in any manner whatsoever, any liability of ST.

ST and the ST logo are trademarks or registered trademarks of ST in various countries.

Information in this document supersedes and replaces all information previously supplied.

The ST logo is a registered trademark of STMicroelectronics. All other names are the property of their respective owners.

© 2013 STMicroelectronics - All rights reserved

STMicroelectronics group of companies

Australia - Belgium - Brazil - Canada - China - Czech Republic - Finland - France - Germany - Hong Kong - India - Israel - Italy - Japan - Malaysia - Malta - Morocco - Philippines - Singapore - Spain - Sweden - Switzerland - United Kingdom - United States of America

[www.st.com](http://www.st.com)