

TC4584BP/BF/BFN

TC4584B HEX SCHMITT TRIGGER

The TC4584B is the 6-circuit inverter having the Schmitt trigger function at the input terminal.

That is, since the circuit threshold level voltages at the leading and trailing edges of input waveform are different (V_P , V_N), the TC4584B can be used in the broad range application including line receiver, waveform shaping circuit, astable multivibrator, monostable multivibrator, etc. In addition to ordinary inverter.

Since the pins are compatible with the TC4069UB, the substitution is also possible.

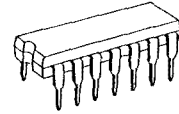

P (DIP14-P-300)



F (SOP14-P-300)



FN (SOL14-P-150)

ABSOLUTE MAXIMUM RATINGS

CHARACTERISTIC	SYMBOL	RATING	UNIT
DC Supply Voltage	V_{DD}	$V_{SS} - 0.5 \sim V_{SS} + 20$	V
Input Voltage	V_{IN}	$V_{SS} - 0.5 \sim V_{DD} + 0.5$	V
Output Voltage	V_{OUT}	$V_{SS} - 0.5 \sim V_{DD} + 0.5$	V
DC Input Current	I_{IN}	± 10	mA
Power Dissipation	P_D	300 (DIP) / 180 (SOIC)	mW
Operating Temperature Range	T_A	$-40 \sim 85$	$^{\circ}\text{C}$
Storage Temperature Range	T_{STG}	$-65 \sim 150$	$^{\circ}\text{C}$
Lead Temp./Time	T_{SOL}	$260^{\circ}\text{C} \cdot 10\text{sec}$	

PIN ASSIGNMENT

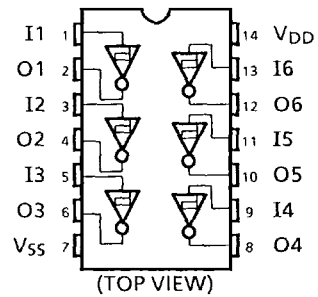

INPUT / OUTPUT VOLTAGE CHARACTERISTIC

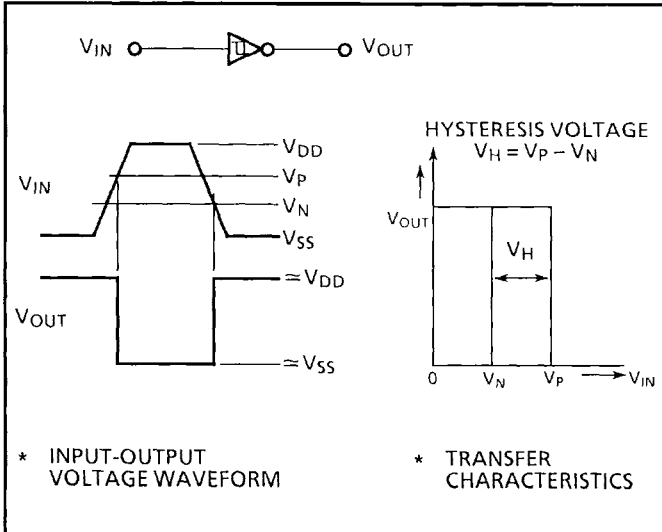

LOGIC DIAGRAM

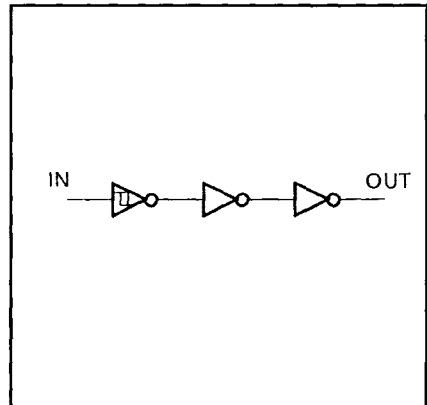

TC4584BP/BF/BN

RECOMMENDED OPERATING CONDITIONS ($V_{SS} = 0V$)

CHARACTERISTICS	SYMBOL	MIN.	TYP.	MAX.	UNITS
DC Supply Voltage	V_{DD}	3	–	18	V
Input Voltage	V_{IN}	0	–	V_{DD}	V

STATIC ELECTRICAL CHARACTERISTICS ($V_{SS} = 0V$)

CHARACTERISTICS	SYMBOL	TEST CONDITIONS	V_{DD} (V)	– 40°C		25°C			85°C		UNITS	
				MIN.	MAX.	MIN.	TYP.	MAX.	MIN.	MAX.		
High-Level Output Voltage	V_{OH}	$ I_{OUT} < 1\mu A$ $V_{IN} = V_{SS}, V_{DD}$	5	4.95	–	4.95	5.00	–	4.95	–	V	
			10	9.95	–	9.95	10.00	–	9.95	–		
			15	14.95	–	14.95	15.00	–	14.95	–		
Low-Level Output Voltage	V_{OL}	$ I_{OUT} < 1\mu A$ $V_{IN} = V_{SS}, V_{DD}$	5	–	0.05	–	0.00	0.05	–	0.05	V	
			10	–	0.05	–	0.00	0.05	–	0.05		
			15	–	0.05	–	0.00	0.05	–	0.05		
Output High Current	I_{OH}	$V_{OH} = 4.6V$ $V_{OH} = 2.5V$ $V_{OH} = 9.5V$ $V_{OH} = 13.5V$ $V_{IN} = V_{SS}, V_{DD}$	5	–0.61	–	–0.51	–1.0	–	–0.42	–	mA	
			5	–2.5	–	–2.1	–4.0	–	–1.7	–		
			10	–1.5	–	–1.3	–2.2	–	–1.1	–		
			15	–4.0	–	–3.4	–9.0	–	–2.8	–		
Output Low Current	I_{OL}	$V_{OL} = 0.4V$ $V_{OL} = 0.5V$ $V_{OL} = 1.5V$ $V_{IN} = V_{SS}, V_{DD}$	5	0.61	–	0.51	1.5	–	0.42	–	mA	
			10	1.5	–	1.3	3.8	–	1.1	–		
			15	4.0	–	3.4	15.0	–	2.8	–		
			–	–	–	–	–	–	–	–		
Positive Trigger Threshold Voltage	V_P	$V_{OUT} = 0.5V$ $V_{OUT} = 1.0V$ $V_{OUT} = 1.5V$	5	2.05	3.75	2.15	3.0	3.75	2.15	3.85	V	
			10	4.8	7.6	4.9	6.4	7.6	4.9	7.7		
			15	7.8	11.6	7.9	9.9	11.6	7.9	11.7		
Negative Trigger Threshold Voltage	V_N	$V_{OUT} = 4.5V$ $V_{OUT} = 9.0V$ $V_{OUT} = 13.5V$	5	1.25	2.95	1.25	2.3	2.85	1.15	2.85	V	
			10	2.4	5.2	2.4	3.8	5.1	2.3	5.1		
			15	3.4	7.2	3.4	5.2	7.1	3.3	7.1		
Hysteresis Voltage	V_H		5	0.10	1.25	0.25	0.65	1.25	0.25	1.40	V	
			10	1.8	3.5	1.9	2.6	3.5	1.9	3.6		
			15	3.7	5.6	3.8	4.7	5.6	3.8	5.7		
Input Current	"H" Level	I_{IH}	$V_{IH} = 18V$	18	–	0.1	–	10^{-5}	0.1	–	1.0	μA
	"L" Level	I_{IL}	$V_{IL} = 0V$	18	–	–0.1	–	-10^{-5}	–0.1	–	–1.0	
Quiescent Device Current	I_{DD}	$V_{IN} = V_{SS}, V_{DD}^*$	5	–	1	–	0.001	1	–	7.5	μA	
			10	–	2	–	0.002	2	–	15		
			15	–	4	–	0.004	4	–	30		

* All valid input combinations.

DYNAMIC ELECTRICAL CHARACTERISTICS (Ta = 25°C, VSS = 0V, CL = 50pF)

CHARACTERISTICS	SYMBOL	TEST CONDITION	V _{DD} (V)	MIN.	TYP.	MAX.	UNITS
Output Transition Time (Low to High)	t _{TLH}		5	–	80	200	ns
			10	–	50	100	
			15	–	40	80	
Output Transition Time (High to Low)	t _{THL}		5	–	80	200	
			10	–	50	100	
			15	–	40	80	
Propagation Delay Time	t _{pLH} t _{pHL}		5	–	170	340	
			10	–	80	160	
			15	–	60	120	
Input Capacitance	C _{IN}		–	5	7.5	pF	

CIRCUIT AND WAVEFORM FOR MEASUREMENT OF DYNAMIC CHARACTERISTICS

