

RP Series TO39 Two-Port SAW Resonators

Electrical Connections

This two-port, three-terminal SAW resonator is bidirectional. However, impedances and circuit board parasitics may not be symmetrical, requiring slightly different oscillator component-matching values.

Pin	Connection
1	Input or Output
2	Output or Input
3	Case Ground

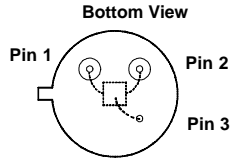

Temperature Characteristics

The curve shown on the right accounts for resonator contribution only and does not include LC component temperature contributions.

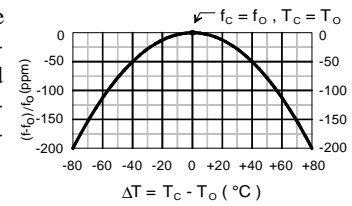

Typical Frequency Response

The plot shown below is a typical frequency response for the RP series of two-port resonators. The plot is for RP1094.

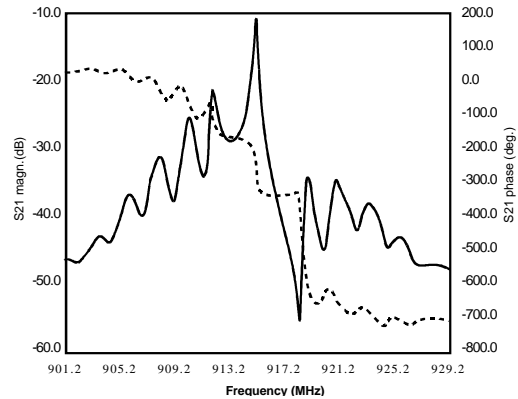

Typical Test Circuit

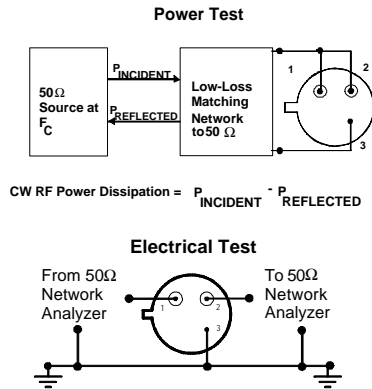

Typical Application Circuits

This SAW resonator can be used in oscillator or transmitter designs that require 180° phase shift at resonance in a two-port configuration. One-port resonators can be simulated, as shown, by connecting pins 1 and 2 together. However, for most low-cost consumer products, this is only recommended for retrofit applications and not for new designs.

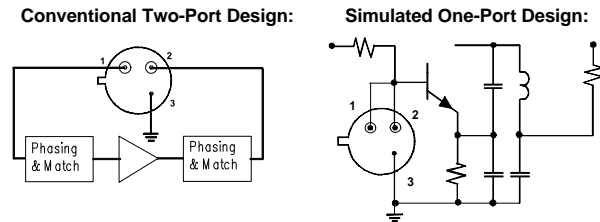

Equivalent LC Model

The following equivalent LC model is valid near resonance:

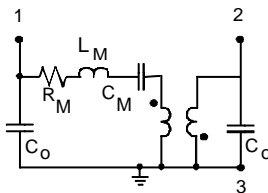

Case Design

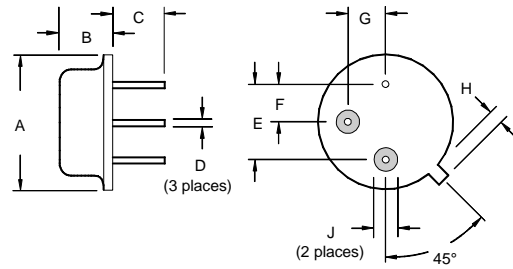

Dimensions	Millimeters		Inches	
	Min	Max	Min	Max
A		9.30		0.366
B		3.18		0.125
C	2.50	3.50	0.098	0.138
D	0.46 Nominal		0.018 Nominal	
E	5.08 Nominal		0.200 Nominal	
F	2.54 Nominal		0.100 Nominal	
G	2.54 Nominal		0.100 Nominal	
H		1.02		0.040
J	1.40		0.055	

RP Series SM-4A Two-Port SAW Resonators

Absolute Maximum Ratings

Rating	Value	Units
CW RF Power Dissipation (See: Typical Test Circuit)	+0	dBm
DC Voltage Between Any Two Pins (Observe ESD Precautions)	±30	VDC
Case Temperature	-40 to +85	°C

Electrical Connections

This two-port, three-terminal SAW resonator is bidirectional. However, impedances and circuit board parasitics may not be symmetrical, requiring slightly different oscillator component-matching values.

Pin	Connection
1	Input or Output
2	Output or Input
3	Case Ground
4	Case Ground

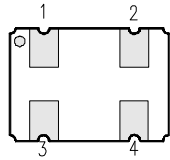

Typical Test Circuit

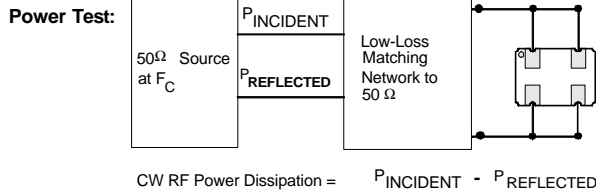
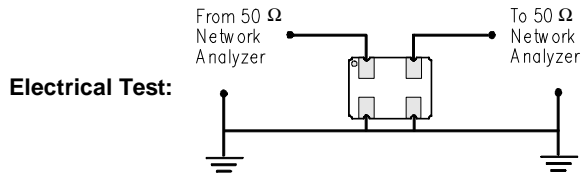

Typical Application Circuits

Simulated One-Port Design:

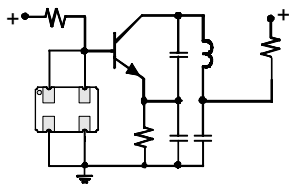

Conventional Two-Port Design:

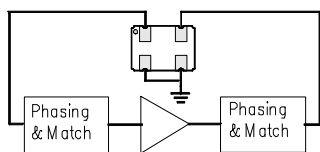

Equivalent LC Model

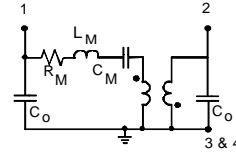

Temperature Characteristics

The curve shown on the right accounts for resonator contribution only and does not include LC component temperature contributions.

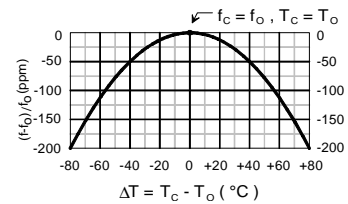

Typical Circuit Board Land Pattern

The circuit board land pattern shown below is one possible design. The optimum land pattern is dependent on the circuit board assembly process which varies by manufacturer. The distance between adjacent land edges should be at a maximum to minimize parasitic capacitance. Trace lengths from terminal lands to other components should be short and wide to minimize parasitic series inductances.

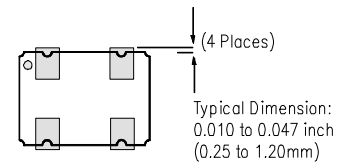

Case Design SM-4A

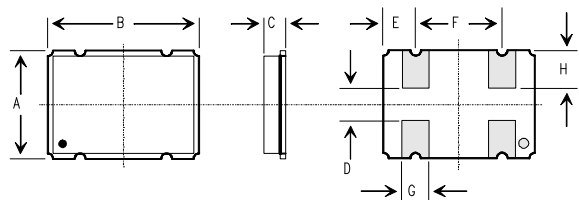

Dimensions SM-4A	Inches	Millimeters
	Nominal	Nominal
A	0.205	5.21
B	0.265	6.73
C	0.078	1.98
D	0.071	1.80
E	0.057	1.45
F	0.150	3.81
G	0.050	1.27
H	0.075	1.91

RP Series

RP Two-Port 180° SAW Resonators

(All parameters measured in 50Ω system)

Part Number	Resonant Freq. at 25°C		Insertion Loss (dB)		Quality Factor		Ratings	Temperature Stability			
	Absolute f_c (MHz)	Tolerance Δf_c (kHz)	Typ.	Max	Unloaded Q	50 W Loaded Q	CW RF Power Dissipation (dBm)	Turnover Temp. T_O (°C)			Turnover Freq. f_O (kHz)
								Min.	Typ.	Max.	Typ.
Notes	2, 3, 4, 5		2, 5, 6		5, 6, 7		Value	6, 7, 8			
RP1234	293.075	±100	13.1	18.0	12,000	9,400	+5	38	53	68	$f_c+8.5$
RP1098	307.3	±100	11.0	18.0	13,000	9,600	+5	33	48	63	f_c+6
RP1053	310.0	±250	14	18	4,000	3,200	0	47	62	77	f_c
RP1239	315.0	±75	5.3	8.5	18,000	8,100	0	37	52	67	$f_c+8.5$
RP1238	407.3	±100	5.4	8.0	13,700	6,300	0	43	58	73	f_c+16
RP1237	418.0	±75	5.7	8.0	13,600	6,500	0	47	62	77	f_c+21
RP1237-1	418.05	±75	5.7	8.0	13,600	6,500	0	47	62	77	f_c+21
RP1298	423.22	±100	5.2	8.0	15,200	6,900	0	24	39	54	$f_c+2.6$
RP1207-5	433.92	±75	8.2	10.0	12,700	7,800	+5	40	55	70	f_c+14
RP1308	433.92	±75	6.3	8.0	12,000	6,300	0	36	51	66	f_c+11
RP1102	905.5	±250	9.5	15.0	6,000	3,500	+5	44	59	74	f_c+39
RP1286	906.0	±100	7.1	10.0	6,600	3,700	+5	16	31	46	f_c+1
RP1261	913.612	±212	8.2	10.0	6,500	4,000	+5	23	38	53	$f_c+5.7$
RP1094	915.0	±150	8.5	15.0	6,100	3,700	+5	53	68	83	f_c+63
RP1285	916.55	±150	7.5	10.0	6,500	3,800	+5	23	38	53	f_c+5
RP1103	924.5	±250	11.1	15.0	6,000	3,800	+5	34	49	64	f_c+6

RO and RP Series Notes

- Frequency aging is the change in f_c with time and is specified at +65°C or less. Aging may exceed the specification for prolonged temperatures above +65°C. Typically, aging is greatest the first year after manufacture, decreasing significantly in subsequent years.
- The frequency f_c is the frequency of minimum IL with the resonator in the specified test fixture in a 50 Ω test system with VSWR ≤ 1.2:1. Typically, $f_{OSCILLATOR}$ or $f_{TRANSMITTER}$ is less than the resonator f_c . $|F_A|$ is typically ±10 ppm/year.
- One or more of the following United States patents apply: 4,454,488; 4,616,197, and others pending.
- Typically, equipment utilizing this device requires emissions testing and government approval, which is the responsibility of the equipment manufacturer.
- Unless noted otherwise, case temperature $T_C = +25°C \pm 5°C$
- The design, manufacturing process, and specifications of this device are subject to change without notice.
- Derived mathematically from one or more of the following directly measured parameters: f_c , IL, 3 dB bandwidth, f_c versus T_C , and C_O .
- Turnover temperature, T_O , is the temperature of maximum (or turnover) frequency, f_O . The nominal frequency at any case temperature, T_C , may be calculated from: $f = f_O [1 - FTC (T_O - T_C)^2]$. Typically, *oscillator* T_O is 20° less than the specified *resonator* T_O .
- This equivalent RLC model approximates RO surface mount resonator performance near the resonant frequency and is

RP Series

RP Two-Port 180° SAW Resonators

(All parameters measured in 50Ω system)

Part Number (Cont.)	RF Equivalent RLC Model							Packaging	Lid Symbol	Application - For Reference Only	
	Motional Res. R_m (Ω)		Motional Cap. C_m (fF)	Motional Ind. L_m (μ H)	Shunt Static Cap. C_O (pF)			Case Style		Typ. Circuit and Freq. (MHz)	Nom. Radio Freq. (MHz)
	Typ.	Max	Typ.	Typ.	Min.	Typ.	Max.				
Notes	5, 6, 7, 9										
RP1234	352	695	0.127215	2.31659	1.0	1.3	1.6	TO39	P1234	293.125 LO	303.825
RP1098	256	695	0.134251	1.99801	1.0	1.3	1.6	TO39	P1098	307.25 LO	318
RP1053	352	695	0.125	2100	1.0	1.3	1.6	TO39	334-A025	310.0TX	310.0
RP1239	84	167	0.336771	758.027	1.9	2.2	2.5	TO39	P1239	315.00 TX	315.00
RP1238	86	152	0.330391	462.150	2.1	2.4	2.7	TO39	P1238	407.30 LO	418.00
RP1237	93	152	0.303334	477.932	2.0	2.3	2.6	TO39	P1237	418.00TX	418.00
RP1237-1	93	152	0.305206	474.887	2.0	2.3	2.6	TO39	1237-1	418.00 TX	418.00
RP1298	82	152	0.297547	475.283	2.2	2.5	2.8	TO39	P1298	423.22 LO	433.92
RP1207-5	157	216	0.183245	734.159	1.4	1.7	2.0	TO39	1207-5	433.92 TX	433.92
RP1308	107	152	0.279470	481.378	1.4	1.7	2.0	TO39	P1308	433.92 TX	433.92
RP1102	198	463	0.106865	289.086	1.0	1.3	1.6	TO39	P1102	905.5 TX	905.5
RP1286	126	216	0.208528	147.985	1.6	1.9	2.2	TO39	P1286	905.80 LO	916.50
RP1261	157	217	0.171332	177.124	1.4	1.7	2.0	TO39	P1261	913.50 TX	913.50
RP1094	166	463	0.158119	191.3434	1.1	1.4	1.7	TO39	P1094	914.95 TX	915
RP1285	137	217	0.194528	155.005	1.7	2.0	2.3	TO39	P1285	916.50 TX	916.50
RP1103	259	463	0.118860	249.340	1.1	1.4	1.7	TO39	P1103	924.5 TX	924.5

provided for reference only. The capacitance C_O is the static (nonmotional) capacitance between the two terminals measured at low frequency (10 MHz) with a capacitance meter. The measurement includes parasitic capacitance with “NC” pads unconnected. Case parasitic capacitance is approximately 0.05 pF. Transducer parallel capacitance can be calculated as: $C_p \approx C_O - 0.05$ pF.

- 9b) This equivalent RLC model approximates RO TO39 resonator performance near the resonant frequency and is provided for reference only. The capacitance C_O is the static (nonmotional) capacitance between the two terminals measured at low frequency (10 MHz) with a capacitance meter. The measurement includes parasitic capacitance with a floating case. For usual grounded case applications (with ground connected to either pin 1 or pin 2 and to the case), add approximately 0.25 pF to C_O .
- 9c) This equivalent RLC model approximates RP TO39 resonator performance near the resonant frequency and is provided for reference only. The capacitance C_O is the measured static (nonmotional) capacitance between either pin 1 and ground or pin 2 and ground. The measurement includes case parasitic capacitance.
- 10) The typical FTC for TO-39 resonators is 0.037 ppm/°C² and the typical FTC for SMRs is 0.032 ppm/°C².
- 11) The DC insulation resistance between any two pins is a minimum of 1 M Ω .
- 12) The DC voltage between any two pins (observe ESD precautions) is \pm 30 VDC.
- 13) The case temperature is rated between -40° to +85°C.
- 14) Soldering temperature is +250°C.
- 15) Maximum nominal insertion phase shift at resonance is 180° for the RP series.