



Thin Film Chip Fuse

Document No	TCPS-XXOS004F
Issued date	2012/06/28
Page	1/19

1. Scope

This specification applies for the fuse series of thin film chip fuse made by TA-I.

2. Construction

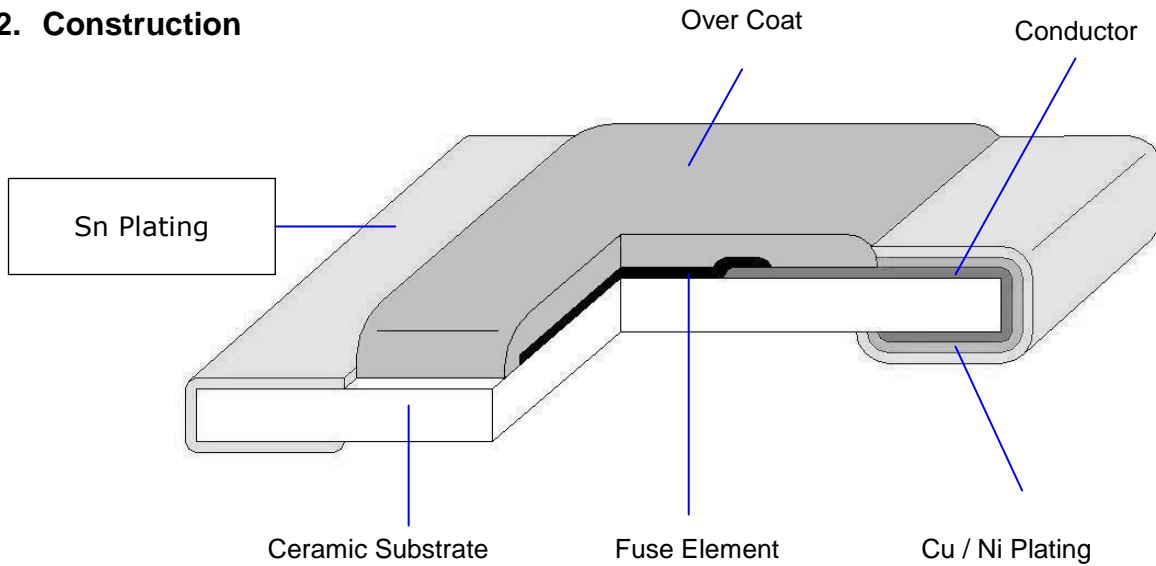

3. Type Designation

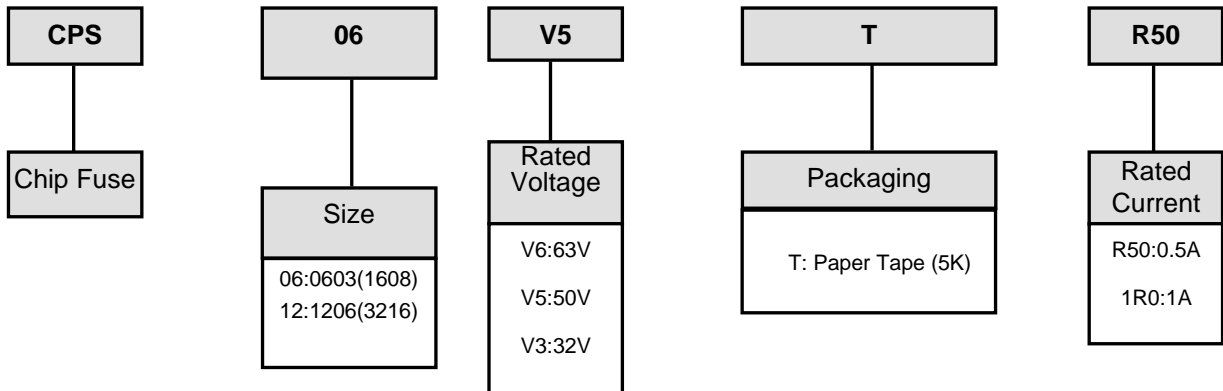



Thin Film Chip Fuse

Document No	TCPS-XXOS004F
Issued date	2012/06/28
Page	2/19

4. Dimensions

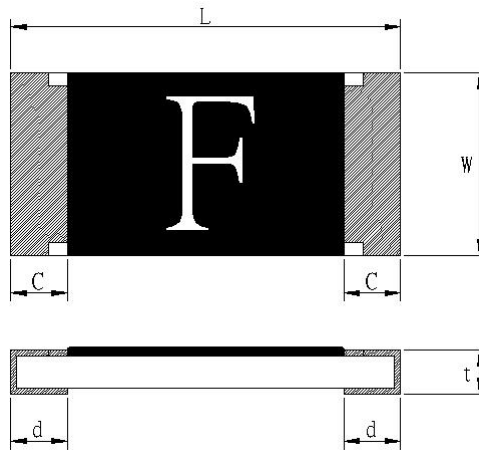

Unit: mm

Type (Inch Size code)	Dimensions (mm)				
	L	W	C	d	t
CPS06 (0603)	1.6±0.1	0.80±0.1	0.3±0.2	0.35±0.2	0.45±0.1
CPS12 (1206)	3.1±0.1	1.55±0.1	0.5±0.3	0.50±0.2	0.60±0.1

5. Applications and ratings

Part Designation	Marking	Rated Current	Fusing Time	Resistance (mΩ) Tolerance±25%	Rated Voltage	Breaking Capacity	Body Temperature rising
CPS06V5TR50	F	0.50A	Open within 1~120sec.at 200% rated current	264	DC 50V	DC50V 50A	<75°C at 100% rated current
CPS06V3TR63	I	0.63A		200	DC 32V	DC32V 50A	
CPS06V3TR80	K	0.80A		143			
CPS06V3T1R0	L	1.00A		83			
CPS06V3T1R25	M	1.25A		54			
CPS06V3T1R50	P	1.50A		42			
CPS06V3T1R60	N	1.60A		40			
CPS06V3T2R0	S	2.00A		28			
CPS06V3T2R50	T	2.50A		21.5			
CPS06V3T3R00	3	3.00A		18			
CPS06V3T3R15	U	3.15A		16			
CPS06V3T4R0	W	4.00A		13			
CPS06V3T5R0	Y	5.00A		9.5			
CPS06V3T6R0	6	6.00A		6			



Thin Film Chip Fuse

Document No	TCPS-XXOS004F
Issued date	2012/06/28
Page	3/19

Part Designation	Marking	Rated Current	Fusing Time	Resistance (mΩ) Tolerance±25%	Rated Voltage	Breaking Capacity	Body Temperature rising
CPS12V6TR50	F	0.50A	Open within 1~120sec. at 200% rated current	738.5	DC 63V	DC63V 50A	<75°C at 100% rated current
CPS12V6TR80	K	0.80A		215			
CPS12V6T1R0	L	1.00A		163.5			
CPS12V6T1R25	M	1.25A		100			
CPS12V6T1R50	P	1.50A		68.5			
CPS12V6T2R0	S	2.00A		48.5			
CPS12V3T2R50	T	2.50A		35	DC 32V	DC32V 50A	
CPS12V3T3R00	3	3.00A		27			
CPS12V3T4R0	W	4.00A		14			
CPS12V3T5R0	Y	5.00A		11			
CPS12V3T7R0	Z	7.00A		7.5			

6. Temperature Derating Curve

6.1 Normal Ambient Temperature: 25°C

6.2 Operating Temperature: -20°C~105°C, whit proper Derating factor as below:

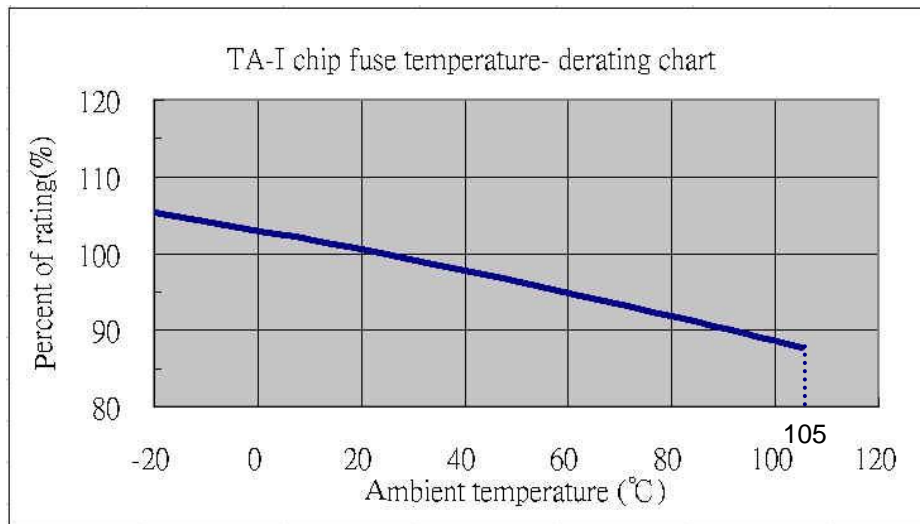



Thin Film Chip Fuse

Document No	TCPS-XXOS004F
Issued date	2012/06/28
Page	4/19

7. Reliability Tests

Parameter	Requirement	Test Method
Carrying capacity	No fusing	Rated current ,4hr
Fusing Time	Within 1~120sec.	200% of its rated current
Interrupting Ability	No mechanical damages	After the fuse is interrupted ,rated voltage applied for 30sec again
Bending Test	No mechanical damages	Distance between holding points: 90mm, Bending:3mm,1time ,30sec
Resistance to solder Heat	±20%	260°C±5°C,10±1second
Solderability	95% coverage minimum	235°C±5°C, 2±0.5second 245°C±5°C, 2±0.5second (Lead Free)
Temperature Rise	<75°C	100% of its rated current, Measure of surface temperature
Resistance to Dry Heat	±20%	105°C±5°C,1000 hrs
Resistance to Solvent	No evident damages on protective coating and marking	23°C±5°C of Isopropyl alcohol 90second
Residual Resistance	10kΩ and more	Measure DC resistance after fusing
Thermal Shock	ΔR< 10 %	-20°C/+25°C/+125°C/+25°C, 10 cycles

8. Marking

Symbol for Rating Current

Symbol	F	I	K	L	<u>M</u>	P	N	S	T	3	U	W	Y	Z
Rating Current(A)	0.5	0.63	0.8	1	1.25	1.5	1.6	2	2.5	3	3.15	4	5	7



9. Taping & Reel

9.1 Taping Dimensions

4mm pitch paper

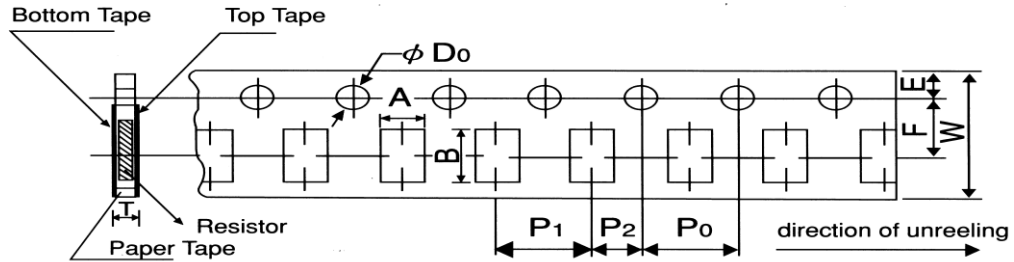

Packing	Type	A	B	W	F	E	P ₁	P ₂	P ₀	D ₀	T
Paper Tape	CPS06	1.1±0.1	1.9±0.1	8.0±0.2	3.5±0.05	1.75±0.1	4.0±0.1	2.0±0.05	4.0±0.1	φ 1.5 +0.1 -0	0.64±0.1
Paper Tape	CPS12	2.0±0.15	3.6±0.2	8.0±0.2	3.5±0.05	1.75±0.1	4.0±0.1	2.0±0.05	4.0±0.1	φ 1.5 +0.1 -0	0.84±0.1

Unit: mm

Type series		Paper Tape
		4 mm pitch
		180mm/R
CPS	06	5000
CPS	12	5000



Thin Film Chip Fuse

Document No	TCPS-XXOS004F
Issued date	2012/06/28
Page	6/19

9.2 Reel Specifications

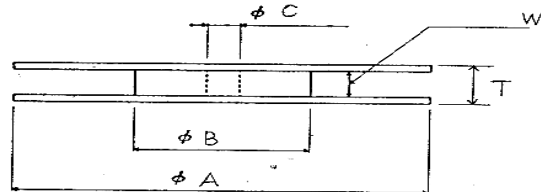
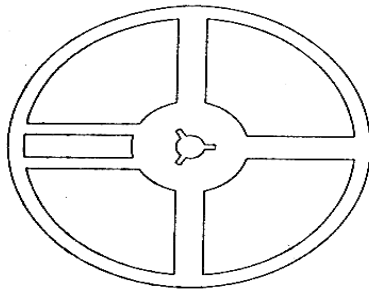

Unit: mm

Series	ϕA	ϕB	ϕC	W	T
CPS06 CPS12	178±2.0	60.0±1.0	13.0±1.0	9.0±1.0	11.4±2.0

9.3 Peel –off force :

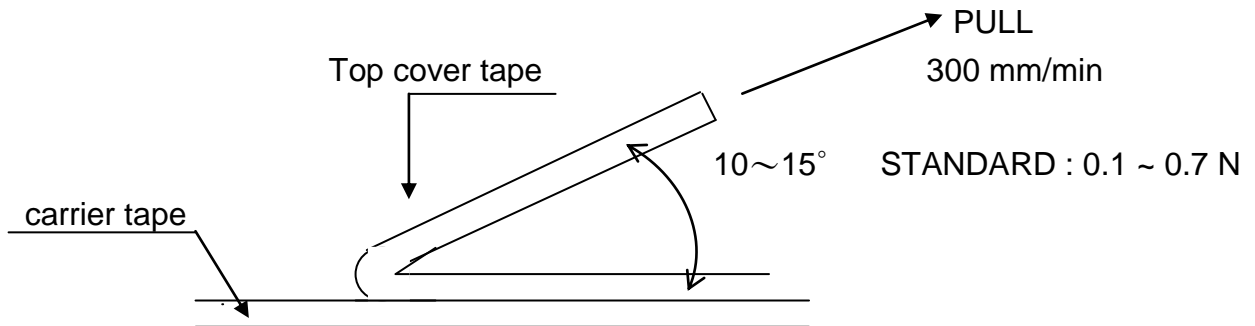

10. Storage Conditions:

Temperature: 5°C~35°C, Humidity: 40%~75%

11. Shelf Life:

2 years from manufacturing date



Thin Film Chip Fuse

Document No	TCPS-XXOS004F
Issued date	2012/06/28
Page	7/19

12. Label

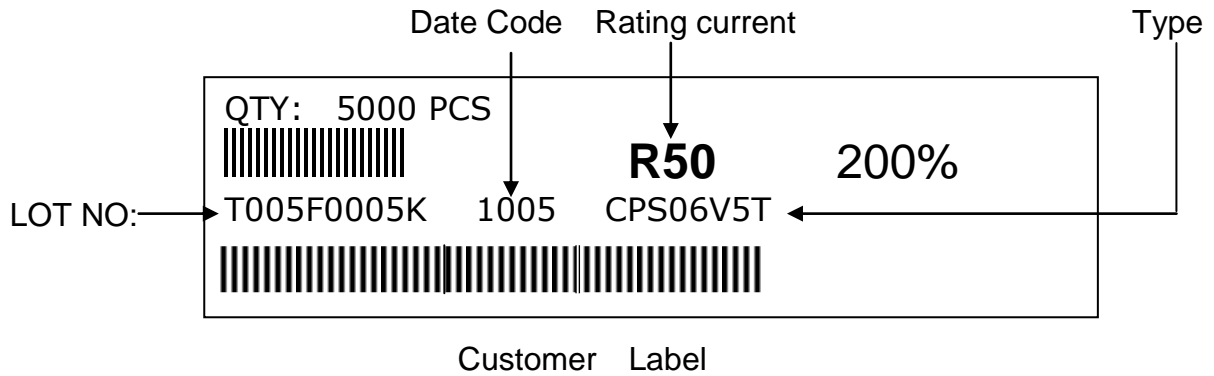

13. Recommended land patterns

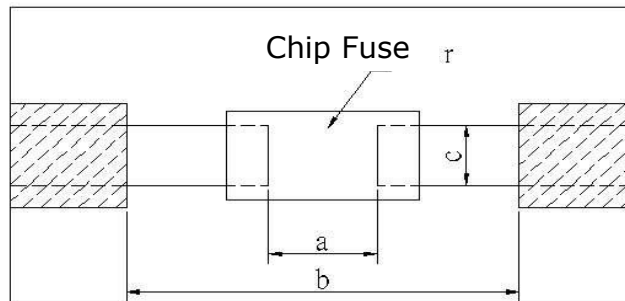

Type	Size	Land pattern		
		Dimension		
		a	b	c
CPS	06 (0603)	0.7~0.9	2.0~2.2	0.8~1.0
CPS	12 (1206)	2.0~2.4	4.4~5.0	1.5~1.8



Thin Film Chip Fuse

Document No	TCPS-XXOS004F
Issued date	2012/06/28
Page	8/19

14. Recommend IR – Reflow profile : (solder : Sn96.5 / Ag3 / Cu0.5)

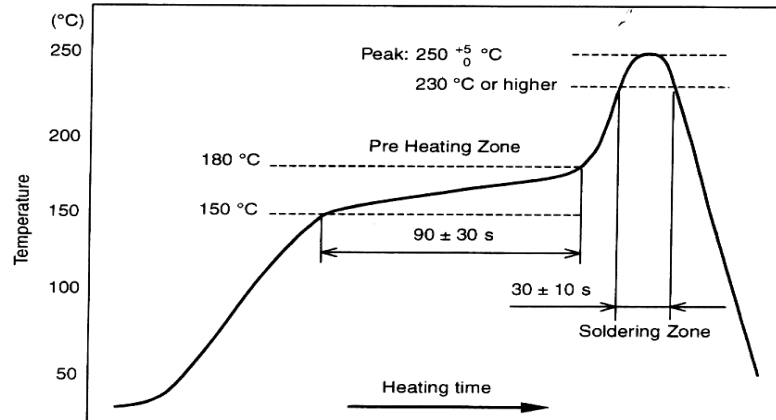

Peak : $250 \begin{smallmatrix} +5 \\ -0 \end{smallmatrix} \text{ } ^\circ\text{C}$, 5 sec

Pre – heat Zone : 150 to 180 °C , $90 \pm 30 \text{ sec}$

Soldering Zone : 230°C or higher , $30 \pm 10 \text{ sec}$

15. Approval by UL248-14

The fuses have been approved by UL.

File No. of UL Recognition is E241710

16. ECN

Engineering Change Notice: The customer will be informed with ECN if there is significant modification on the characteristics and materials described in Approval Sheet.



Thin Film Chip Fuse

Document No	TCPS-XXOS004F
Issued date	2012/06/28
Page	9/19

17. Manufacturing Country & City :

TA-I TECHNOLOGY CO., LTD. (Taiwan– Tao Yuan)

Tel: (+886) 3-3246169 Fax : (+886) 3-3246167

Associated companies :

(1)TA-I TECHNOLOGY (SU ZHOU) CO., LTD. (China – Su Zhou)

Tel : (+86) 512-63457879 Fax : (+86) 512-63457869

(2) TA-I TECHNOLOGY ELECTRONIC (DONGGUAN) CO., LTD. (China –Dongguan)

Tel : (+86) 769-8339-4790~3 Fax : (+86) 769-8339-4794

(3) FORTUNE TASK RESISTOR FACTORY (China – Dongguan)

Tel : (+86) 769-8339-4790~3 Fax : (+86) 769-8339-4794

(4) TAI OHM ELECTRONICS (M) SDN. BHD. (Malaysia – Penang)

Tel : (+60) 4- 3900480 Fax : (+60) 4-3901481

(5) P.T.TAI ELECTRONIC Indonesia (Indonesia – Jakarta)

Tel : (+62) 21-89830123 Fax : (+62) 21-89830703



Document No	TCPS-XXOS004F
Issued date	2012/06/28
Page	10/19

Selection Guideline of Fuse:

■ Checklist of selection factors

- ⊙ Normal operating current
- ⊙ Normal operating voltage (AC or DC)
- ⊙ Ambient Temperature
- ⊙ Overload current and length of time in which the fuse must open .
- ⊙ Type of fuse (SMD or Tube) and physical size limitation (0603 or 1206)
- ⊙ Agency Approval required (e.g., UL248-14)

■ Normal operating current

e.g., Rectangular Wave , If $I_p = 1.5 A$, Normal operating current = 1.5 A

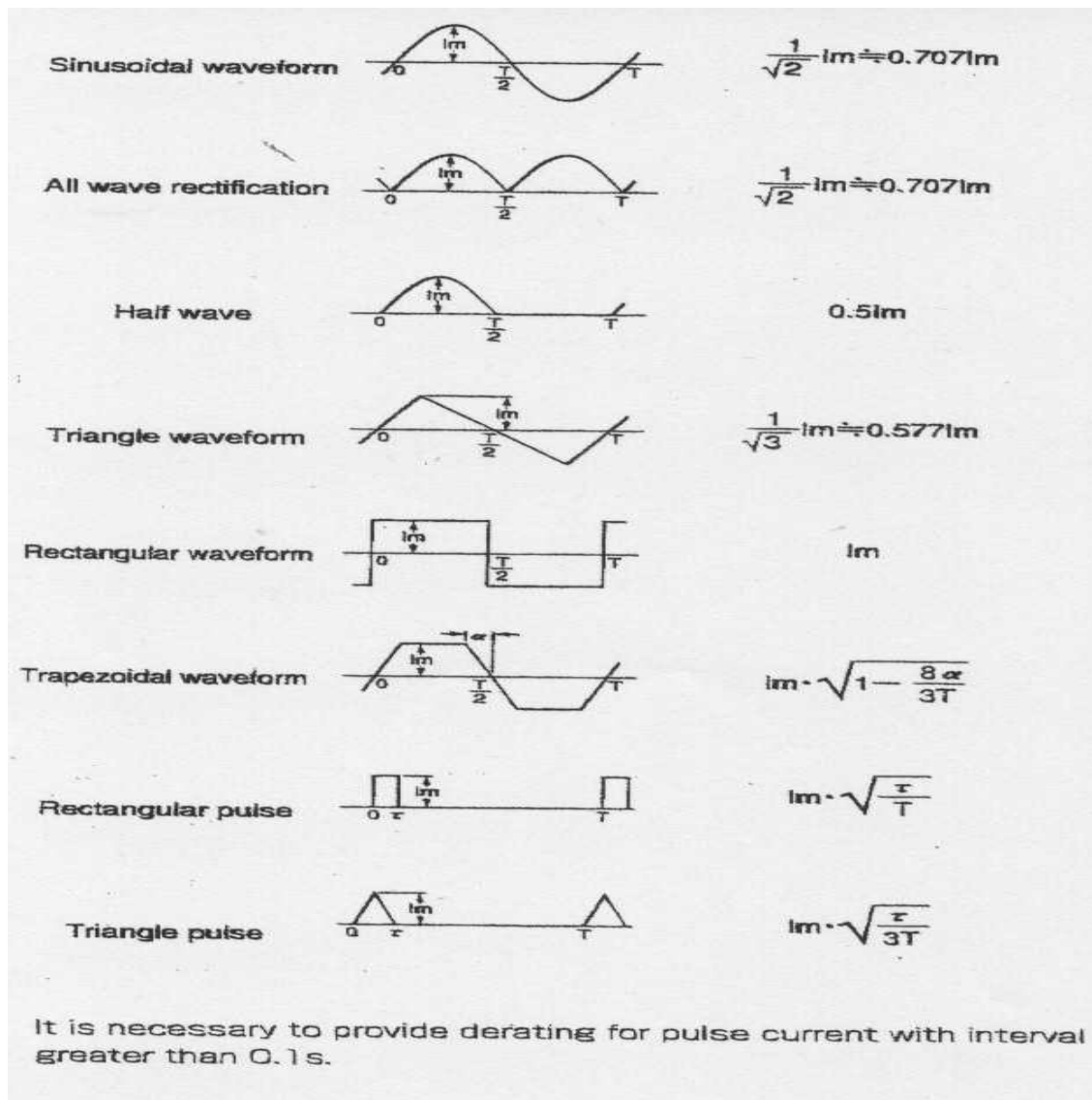



Thin Film Chip Fuse

Document No	TCPS-XXOS004F
Issued date	2012/06/28
Page	11/19

Derating ratio for different ambient Temperature

Referring to bottom figure and select the appropriate derating ratio :

e.g., Ambient temperature is 60 degree C

the derating ratio \approx 0.95

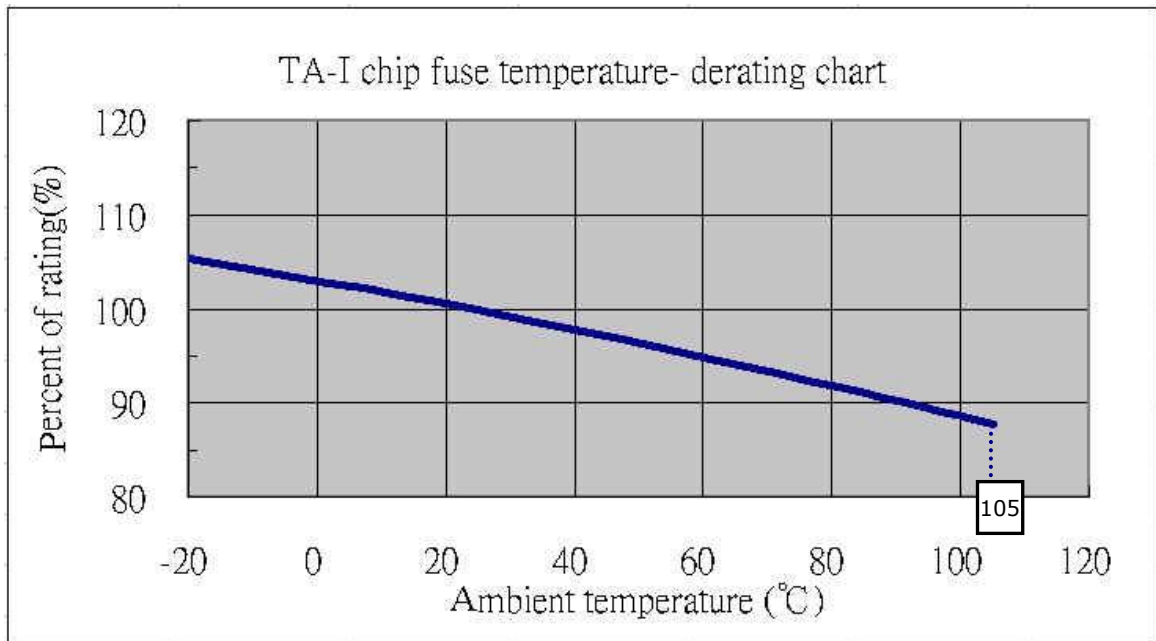

Calculating the required rating of fuse needed .

Safety coefficient : 70 % is safety coefficient from practical experience

$$\frac{\text{Normal Operating Current}}{0.7 \times \text{derating ratio}} < \text{rating current of fuse}$$

\swarrow Safety coefficient \searrow Ambient temperature

e.g.,

Condition : Normal operating current =3.5 A

Ambient temperature 40 °C : Derating ratio \approx 0.95

$$\frac{3.5}{0.7 \times 0.95} < \text{rating current of fuse}$$

5.263 < rating current of fuse



Thin Film Chip Fuse

Document No	TCPS-XXOS004F
Issued date	2012/06/28
Page	12/19

■ Determination of the type of fuse

e.g., Condition :

- ◆ Calculating value = 5.263 A , 5.263A < rating current of fuse
- ◆ Normal operating voltage : DC 12 V
- ◆ Following bottom index-table :

Suggesting use CPS06V3T6R0 .

Part Designation	Marking	Rated Current	Rated Voltage	Part Designation	Marking	Rated Current	Rated Voltage
CPS06V5TR50	F	0.5A	50V	CPS12V6TR50	F	0.50A	63V
CPS06V3TR63	I	0.63A	32V	CPS12V6TR80	K	0.80A	63V
CPS06V3TR80	K	0.80A	32V	CPS12V6T1R0	L	1.00A	63V
CPS06V3T1R0	L	1.00A	32V	CPS12V6T1R25	<u>M</u>	1.25A	63V
CPS06V3T1R25	<u>M</u>	1.25A	32V	CPS12V6T1R50	P	1.50A	63V
CPS06V3T1R50	P	1.50A	32V	CPS12V6T2R0	S	2.00A	63V
CPS06V3T1R60	N	1.60A	32V	CPS12V3T2R50	T	2.50A	32V
CPS06V3T2R0	S	2.00A	32V	CPS12V3T3R00	3	3.00A	32V
CPS06V3T2R50	T	2.50A	32V	CPS12V3T4R0	W	4.00A	32V
CPS06V3T3R00	3	3.00A	32V	CPS12V3T5R0	Y	5.00A	32V
CPS06V3T3R15	U	3.15A	32V	CPS12V3T7R0	Z	7.00A	32V
CPS06V3T4R0	W	4.00A	32V				
CPS06V3T5R0	Y	5.00A	32V				
CPS06V3T6R0	<u>6</u>	6.00A	32V				

■ Inrush current :

- ◆ Considering inrush waveform & calculate I^2t (A²s) value
- ◆ Choosing fuse's I^2t (A²s) value > calculate I^2t (A²s) value
- ◆ Considering Ratio of I^2t repeat numbers to blowing
- ◆ Confirm with us

e.g., choosing 0603 Fuse

Condition :

1. Rectangular Wave , $I_p = 9 \text{ A}$, $t = 1 \text{ (ms)}$,
 Calculate $I_p^2t = 9^2 \times 1 \times 10^{-3} = 0.081 \text{ (A}^2\text{s)}$
2. Choosing CPS06V3T6R0 ($I^2t = 1.86 \text{ (A}^2\text{s)}$) , \Rightarrow Page 13 index-table
3. Inrush shock : 100,000 times (≈ 0.35) \Rightarrow Inrush derating ratio

Calculating :

\Rightarrow Inrush 100,000 times

1. Choosing fuse's I^2t (A²s) value X Derating ratio > calculate I^2t (A²s) value



Thin Film Chip Fuse

Document No	TCPS-XXOS004F
Issued date	2012/06/28
Page	13/19

2. $1.86 \times 0.35 = 0.651 \text{ (A}^2\text{s)}$

3. $0.651 > 0.081$

The fuse is able to meet circuit's application

TA-I FUSE $I^2t \text{ (A}^2\text{ s)}$			
Part Number	Typical $I^2t \text{ (A}^2\text{ s)}$	Part Number	Typical $I^2t \text{ (A}^2\text{ s)}$
CPS06V5TR50	0.009	CPS12V6TR50	0.027
CPS06V3TR63	0.014	CPS12V6TR80	0.072
CPS06V3TR80	0.023	CPS12V6T1R0	0.134
CPS06V3T1R0	0.036	CPS12V6T1R25	0.233
CPS06V3T1R25	0.056	CPS12V6T1R50	0.305
CPS06V3T1R50	0.081	CPS12V6T2R0	0.509
CPS06V3T1R60	0.092	CPS12V3T2R50	0.777
CPS06V3T2R0	0.145	CPS12V3T3R00	1.285
CPS06V3T2R50	0.229	CPS12V3T4R0	2.374
CPS06V3T3R00	0.332	CPS12V3T5R0	5.510
CPS06V3T3R15	0.365	CPS12V3T7R0	10.170
CPS06V3T4R0	0.574		
CPS06V3T5R0	0.927		
CPS06V3T6R0	1.860		

Note*: Typical I^2t value is measured at 10x-rated current, Application with surge over 10x-rated current.

Please confirm with us.

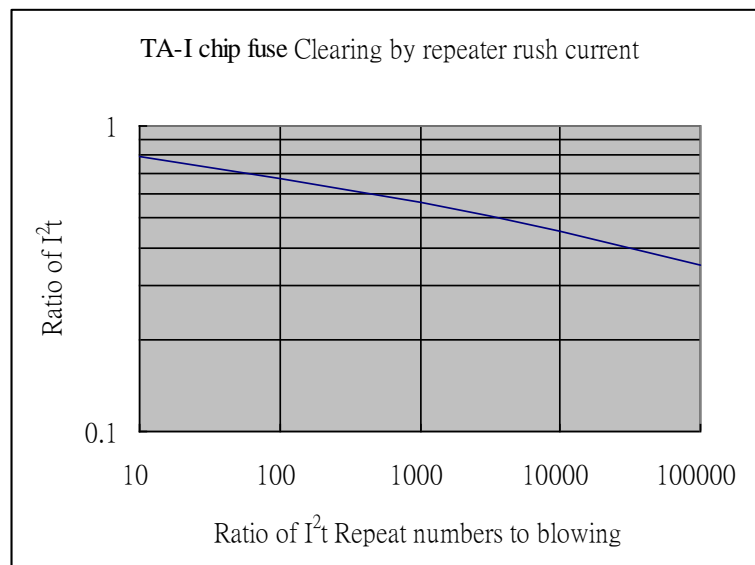



Inrush Waveform

Sinusoidal waveform (1 cycle)		$\frac{1}{2} Im^2 t$
Sinusoidal waveform (1/2 cycle)		$\frac{1}{2} Im^2 t$
Triangle waveform		$\frac{1}{3} Im^2 t$
Rectangular waveform		$Im^2 t$
Trapezoidal waveform		$\frac{1}{3} Im^2 t_1 + Im^2 (t_2 - t_1) + \frac{1}{3} Im^2 (t_3 - t_2)$
Various waveform 1		$I_1 I_2 t + \frac{1}{3} (I_1 - I_2)^2 t$
Various waveform 2		$\frac{1}{3} I_1^2 t_1 + \{I_1 I_2 + \frac{1}{3} (I_1 - I_2)^2\} (t_2 - t_1) + \frac{1}{3} I_2^2 (t_3 - t_2)$
Charge/Discharge waveform		$\frac{1}{2} Im^2 \tau$
Lightning surge waveform		$Im^2 \{t_1/3 + 0.721 (t_2 - t_1)\}$



Thin Film Chip Fuse

Document No	TCPS-XXOS004F
Issued date	2012/06/28
Page	15/19

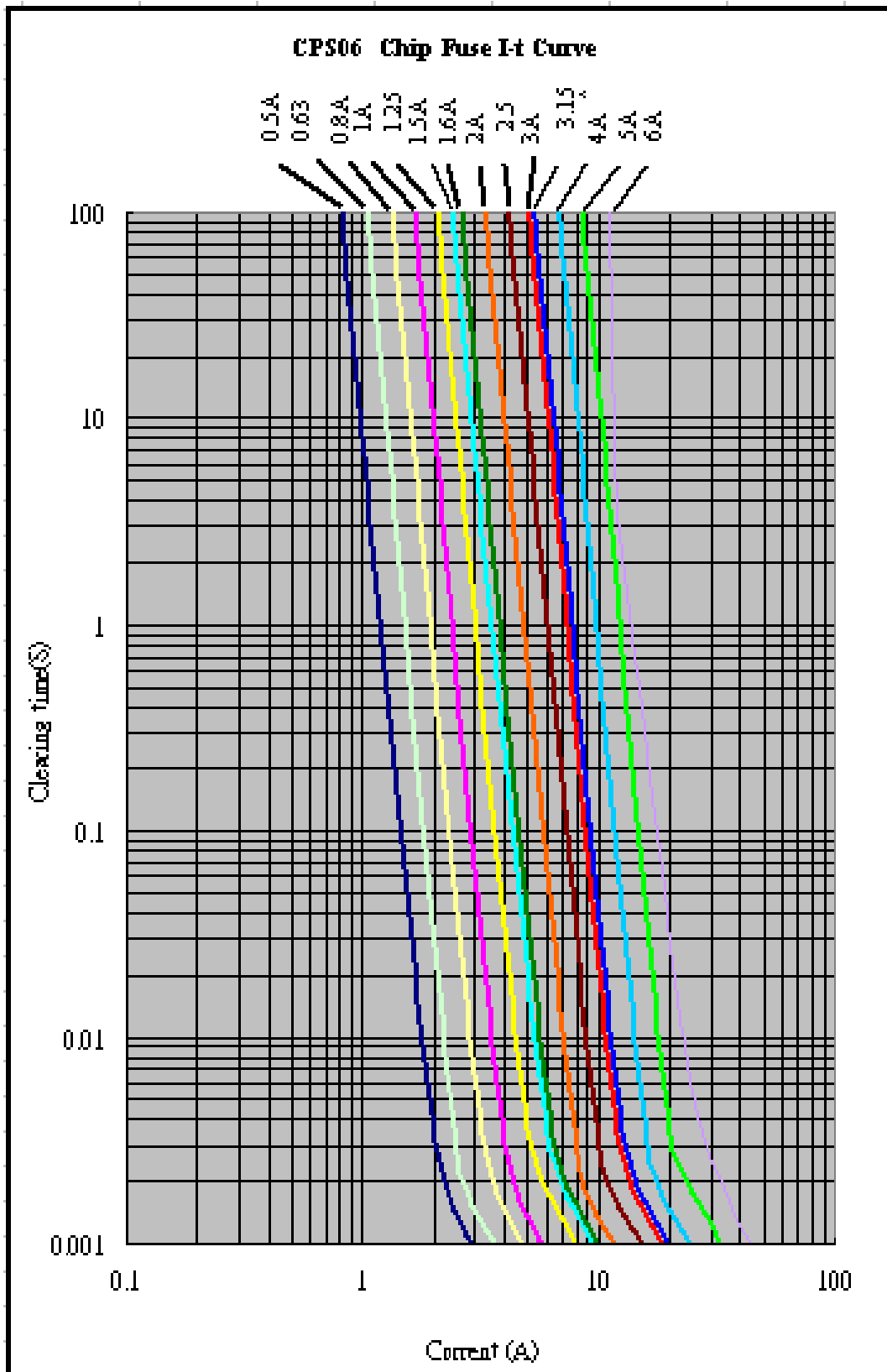



Thin Film Chip Fuse

Document No	TCPS-XXOS004F
Issued date	2012/06/28
Page	16/19

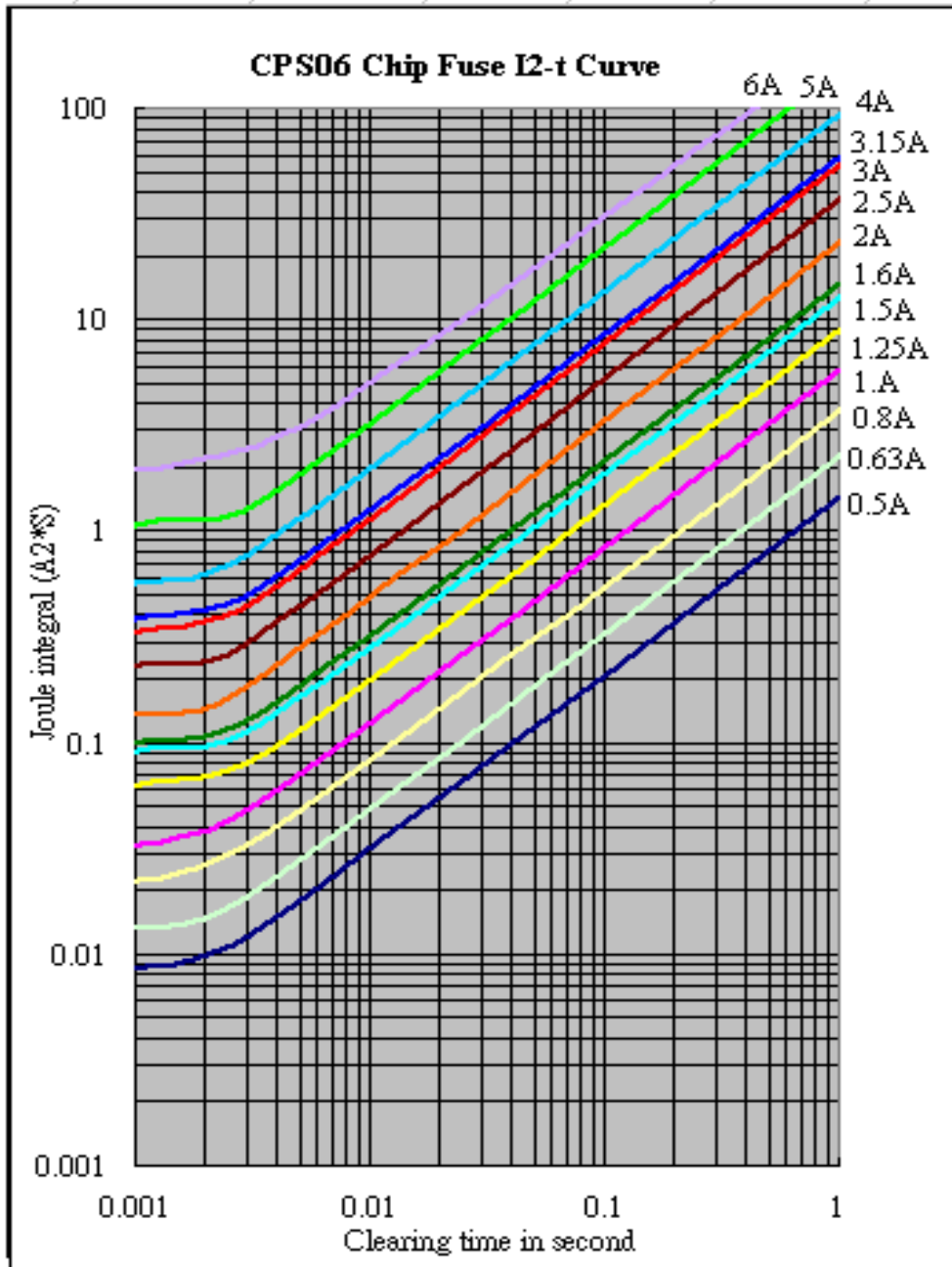



Thin Film Chip Fuse

Document No	TCPS-XXOS004F
Issued date	2012/06/28
Page	17/19

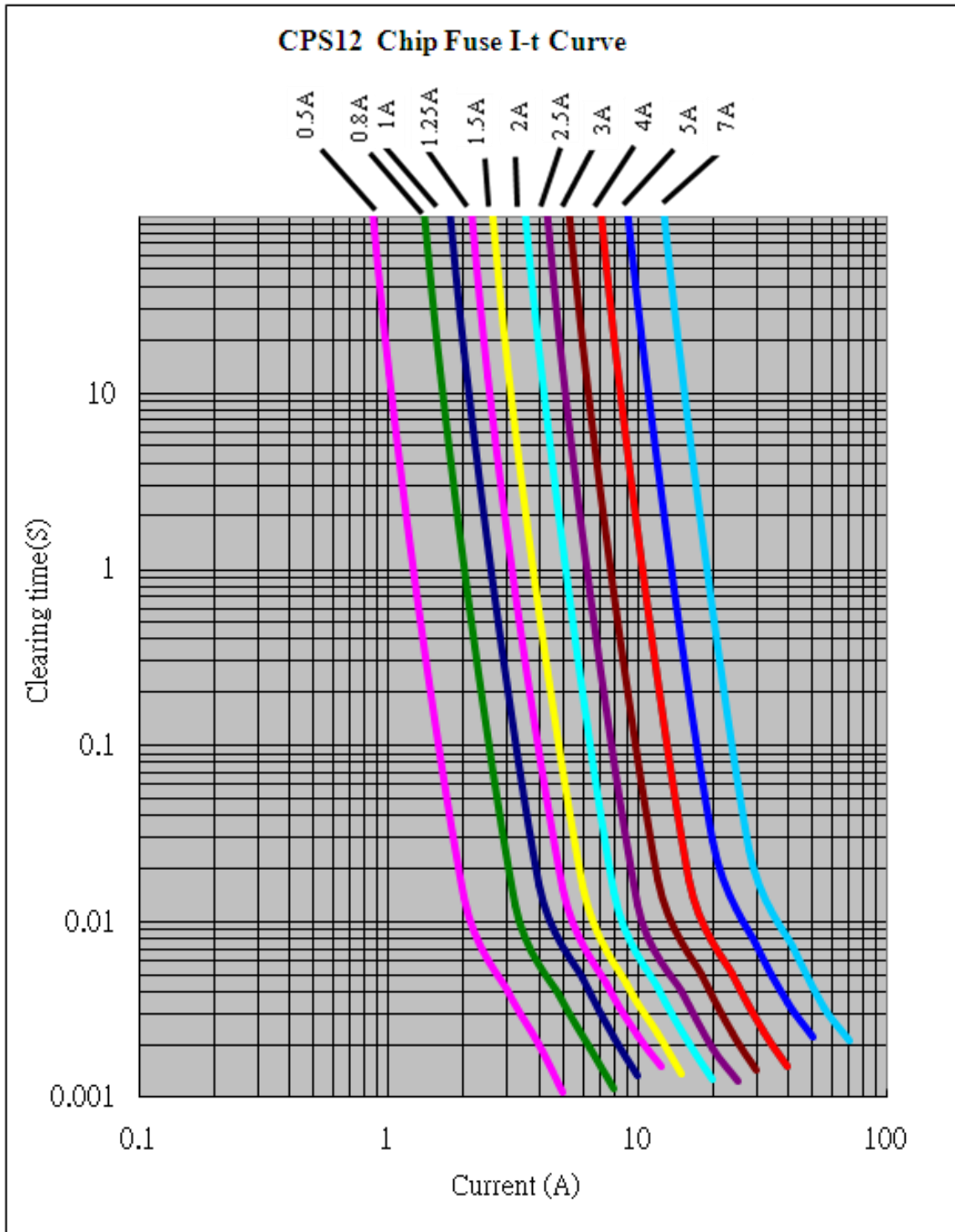



Thin Film Chip Fuse

Document No	TCPS-XXOS004F
Issued date	2012/06/28
Page	18/19

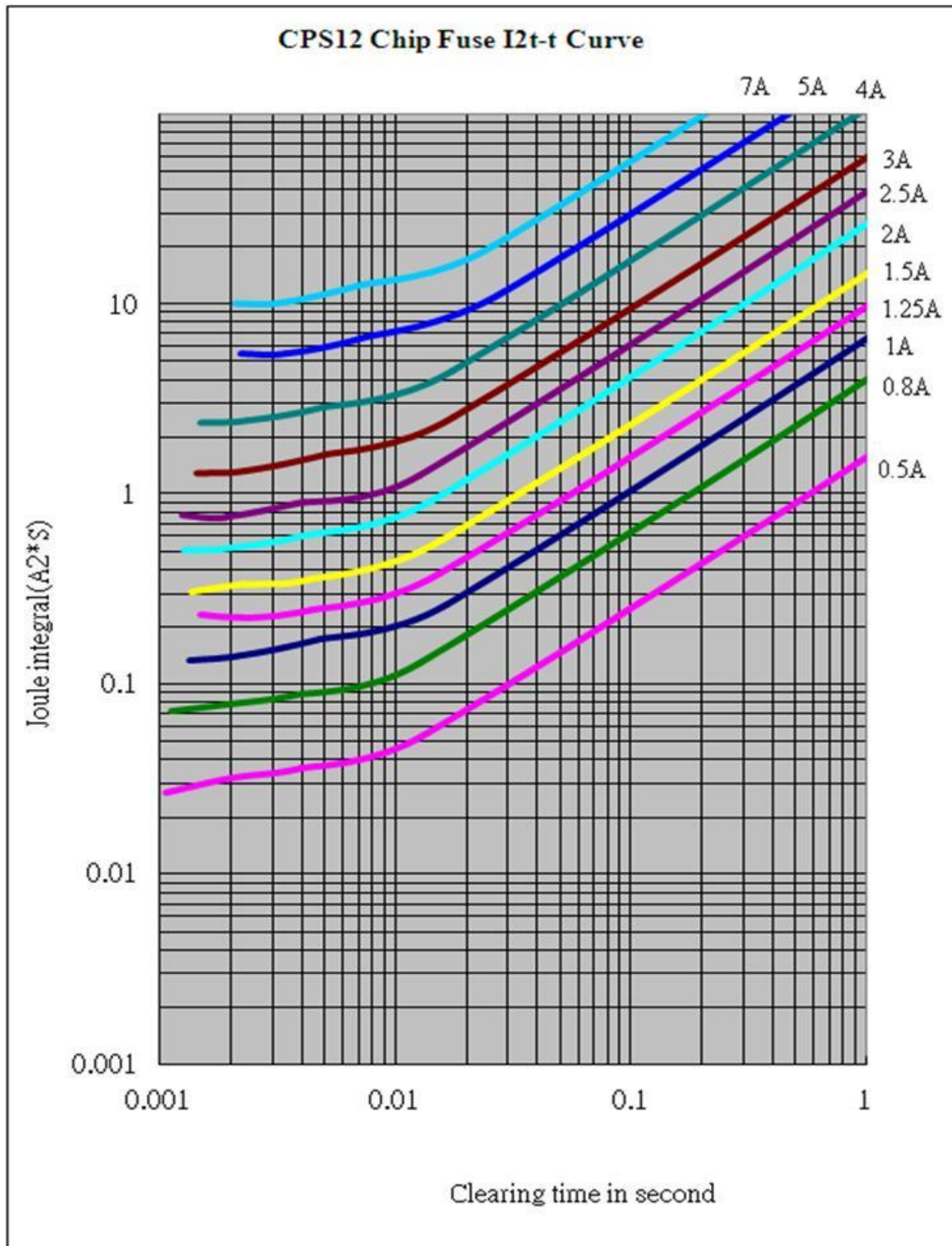



Thin Film Chip Fuse

Document No	TCPS-XXOS004F
Issued date	2012/06/28
Page	19/19

Revise record

Date	Content	Owner
Oct.14.2010	Addiction : 1.Fuse的內阻值 2.Fuse 的 I-T Cuve	Andy
2010/11/19	Before : Resistance (mΩ) Typ.* After : Resistance (mΩ) Tolerance±25%	Andy
2011/02/18	Before : CPS06V3 Rated voltage and Breaking Capacity : DC 32V After : CPS06V3 Rated voltage and Breaking Capacity : AC/DC 32V	Cash