

REV.	DESCRIPTION	DATE	APPROVED
B	Engineering Update w/o Changes	03/01/04	M. C.
C	Mounting Hole Update	04/09/09	T. Y.
D	Removed -102 and -134 Parts	08/25/09	T. Y.
E	Tolerance Update on .475" Thickness	09/09/10	T. Y.
F	Updated Notes with Mounting Instructions	02/05/14	J.C.

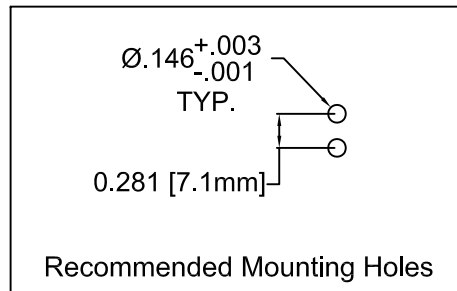

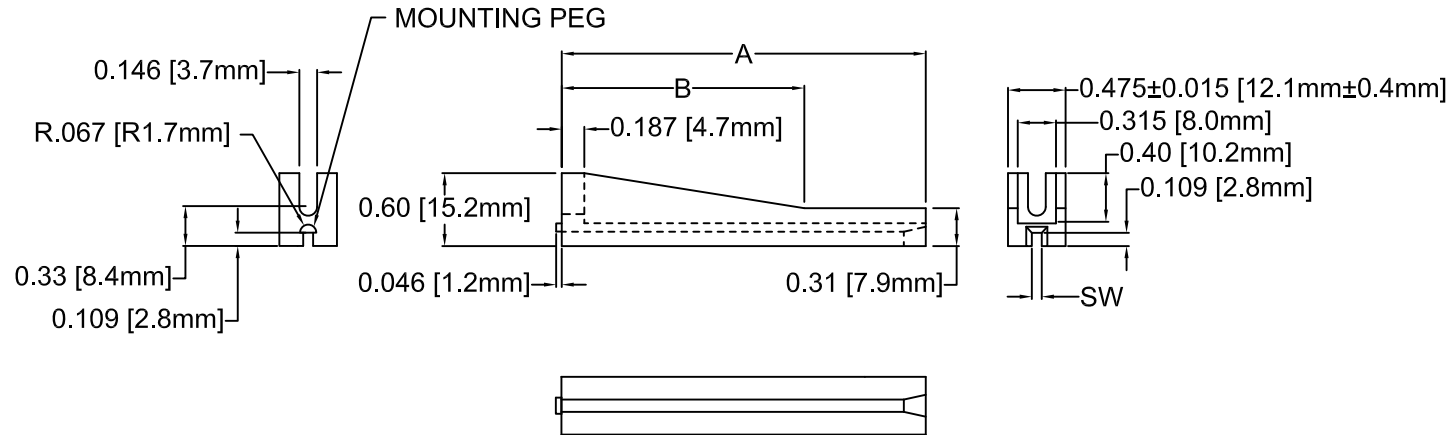

PART NO.	A ±.015 (.38)	B ±.015 (.38)	SW 1/16" PCB
VG2-2	2.0 (50.8)	1.5 (38.1)	.076 (1.9)
VG2-25	2.5 (63.5)	1.5 (38.1)	
VG2-3	3.0 (76.2)	2.0 (50.8)	
VG2-35	3.5 (88.9)		
VG2-4	4.0 (101.6)		
VG2-45	4.5 (114.3)		
VG2-5	5.0 (127.0)		
VG2-55	5.5 (139.7)		
VG2-6	6.0 (152.4)		

3. MOUNTING INSTRUCTIONS: INSERT MOUNTING PEG INTO .146" HOLE AND TAPPING SCREW THROUGH SECOND .146" HOLE. PITCH IS .281".

2. MATERIAL: NYLON 6, 10% GLASS, 94V-0, BLACK.

1. GENERAL SPECIFICATIONS: BIVAR MOLDED COMPONENT SPECIFICATION BV00-E101.

STANDARD TOLERANCE ( UNLESS OTHERWISE SPECIFIED )		 4 THOMAS, IRVINE, CA. 92618 TEL: (949) 951-8808 FAX: (949) 951-3974	
DECIMALS	ANGULAR		
.X ±.1	X° ± 1°		TITLE: VERTICAL PCB CARD GUIDE
.XX ±.01			PART NO: VG2-XX-XXX
.XXX ±.005			REVISION: F
DESIGNED: David Green	DATE: 11/22/02	CAGE CODE : 32559	SHEET # 1 OF 1
CHECKED: M. Chen	DATE: 11/22/02	CAD GENERATED DOCUMENT, DO NOT MEASURE DRAWING.	