

## PROFIBUS Compatible Isolated RS485 Interface

### Functional Diagram

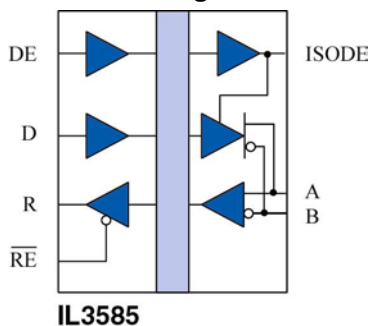

$V_{ID} (A-B)$	DE	RE	R	D	Mode
$\geq 200 \text{ mV}$	L	L	H	X	Receive
$\leq -200 \text{ mV}$	L	L	L	X	Receive
$\geq 1.5 \text{ V}$	H	L	H	H	Drive
$\leq -1.5 \text{ V}$	H	L	L	L	Drive
X	X	H	Z	X	Hi Z R

### Features

- 3.3 / 5 V Input Supply Compatible
- 2500  $V_{RMS}$  Isolation (1 min)
- 20 ns Propagation Delay
- 40 Mbps Data Rate
- 5 ns Pulse Skew
- 20 kV/us Transient Immunity
- Thermal Shutdown Protection
- $-40^{\circ}\text{C}$  to  $+85^{\circ}\text{C}$  Temperature Range
- PROFIBUS Compliant
- 16 Pin SOIC Package
- UL1577 Approval Pending
- IEC 61010-1 Approval Pending

### Applications

- Security Networks
- ProfiBus DP and FMS Networks
- Building Environmental Controls
- Industrial Control Networks
- Gaming Systems
- Factory Automation

### Description

The IL3585 is a galvanically isolated, high-speed differential bus transceiver, designed for bi-directional data communication on balanced transmission lines. Isolation is achieved through patented\* Isolooop<sup>®</sup> technology. The IL3585 offers an exceptional 2.5 V differential output into a 54  $\Omega$  load, which translates to better data integrity over longer cable lengths, even at data rates as high as 40 Mbps. The device is also compatible with 3.3V input supplies, allowing interface to standard microcontrollers without the need for additional level shifting components.

The IL3585 has current limiting and thermal shutdown features to protect against output short circuits and bus contention situations which may cause excessive power dissipation.

## Absolute Maximum Ratings<sup>(1)</sup>

Parameters	Symbol	Min.	Typ.	Max.	Units	Test Conditions
Storage Temperature	$T_S$	-65		150	°C	
Ambient Operating Temperature	$T_A$	-40		100	°C	
Voltage Range at A or B Bus Pins		-7		12	V	
Supply Voltage <sup>(1)</sup>	$V_{DD1}, V_{DD2}$	-0.5		7	V	
Digital Input Voltage		-0.5		$V_{DD}+0.5$	V	
Digital Output Voltage		-0.5		$V_{DD}+1$	V	

## Recommended Operating Conditions

Parameters	Symbol	Min.	Typ.	Max.	Units	Test Conditions
Supply Voltage	$V_{DD1}$ $V_{DD2}$	3.0 4.5		5.5 5.5	V	
Input Voltage at any Bus Terminal (separately or common mode)	$V_I$ $V_{IC}$			12 -7	V	
High-Level Digital Input Voltage	$V_{IH}$	2.4 3.0			V	$V_{DD1}=3.3\text{ V}$ $V_{DD1}=5.0\text{ V}$
Low-Level Digital Input Voltage	$V_{IL}$			0.8	V	
Differential Input Voltage <sup>(2)</sup>	$V_{ID}$			+12/-7	V	
High-Level Output Current (Driver)	$I_{OH}$	-60		60	mA	
High-Level Digital Output Current (Receiver)	$I_{OH}$	-8		8	mA	
Low-Level Output Current (Driver)	$I_{OL}$	-60		60	mA	
Low-Level Digital Output Current (Receiver)	$I_{OL}$	-8		8	mA	
Ambient Operating Temperature	$T_A$	-40		85	°C	
Digital Input Signal Rise and Fall Times	$t_{IR}, t_{IF}$					DC Stable

## Insulation Specifications

Parameters	Symbol	Min.	Typ.	Max.	Units	Test Conditions
Creepage Distance (external)		8.077				
Barrier Impedance $\Omega \parallel \text{pF}$			$>10^{14} \parallel 7$			
Leakage Current			0.2		$\mu\text{A}_{RMS}$	240 $V_{RMS}$ , 60 Hz

## Safety & Approvals

### IEC61010-1

TUV Certificate Numbers: *Approval Pending*

### Classification

Model	Package	Pollution Degree	Material Group	Max. Working Voltage
IL3585	SOIC (0.3")	II	III	300 $V_{RMS}$

### UL 1577

Component Recognition program. File #: *Approval Pending*  
 Rated 2500 $V_{RMS}$  for 1 minute (SOIC)

## Electrostatic Discharge Sensitivity

This product has been tested for electrostatic sensitivity to the limits stated in the specifications. However, NVE recommends that all integrated circuits be handled with appropriate care to avoid damage. Damage caused by inappropriate handling or storage could range from performance degradation to complete failure.

## Pin Connections

1	V <sub>DD1</sub>	Input Power Supply
2	GND <sub>1</sub>	Input Power Supply Ground Return. (Pin 2 is internally connected to Pin 8)
3	R	Output Data from Bus
4	$\overline{\text{RE}}$	Read Data Enable (if $\overline{\text{RE}}$ is high, R= high impedance)
5	DE	Drive Enable
6	D	Data Input to Bus
7	NC	No Internal Connection
8	GND <sub>1</sub>	Input Power Supply Ground Return. (Pin 8 is internally connected to Pin 2)
9	GND <sub>2</sub>	Output Power Supply Ground Return. (Pin 9 is internally connected to Pin 15)
10	ISODE	Isolated DE Output for us in Profibus applications where the state of the isolated drive enable node needs to be monitored.
11	NC	No Internal Connection
12	A	Non-inverting bus line
13	B	Inverting bus line
14	NC	No Internal Connection
15	GND <sub>2</sub>	Output Power Supply Ground Return. (Pin 15 is internally connected to Pin 9)
16	V <sub>DD2</sub>	Output Power Supply

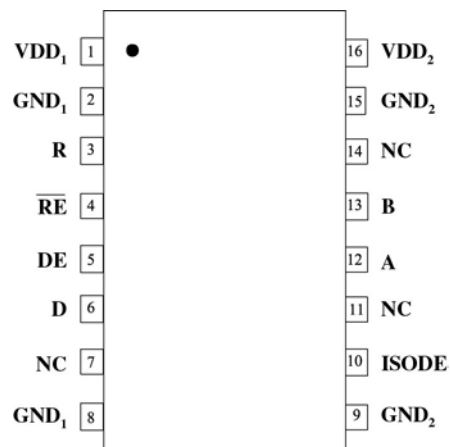

## Driver Section

Electrical Specifications are  $T_{min}$  to  $T_{max}$  unless otherwise stated.

Parameters	Symbol	Min.	Typ. <sup>(5)</sup>	Max.	Units	Test Conditions
Input Clamp Voltage	$V_{IK}$			-1.5	V	$I_L = -18$ mA
Output voltage	$V_O$			$V_{DD}$	V	$I_O = 0$
Differential Output Voltage <sup>(2)</sup>	$ V_{OD1} $			$V_{DD}$	V	$I_O = 0$
Differential Output Voltage <sup>(2)</sup>	$ V_{OD2} $	2.5	3	5	V	$R_L = 54 \Omega$ , $V_{DD} = 5$ V
Differential Output Voltage <sup>(2)(6)</sup>	$V_{OD3}$	2.3		5	V	$R_L = 54 \Omega$ , $V_{DD} = 4.5$ V
Change in Magnitude of Differential Output Voltage <sup>(7)</sup>	$\Delta V_{OD} $			$\pm 0.2$	V	$R_L = 54 \Omega$ or $100 \Omega$
Common Mode Output Voltage	$V_{OC}$			3	V	$R_L = 54 \Omega$ or $100 \Omega$
Change in Magnitude of Common Mode Output Voltage <sup>(7)</sup>	$\Delta V_{OC} $			$\pm 0.2$	V	$R_L = 54 \Omega$ or $100 \Omega$
Output Current <sup>(4)</sup>	$I_O$			1 -0.8	mA	Output Disabled, $V_O = 12$ $V_O = -7$
High Level Input Current	$I_{IH}$			10	$\mu$ A	$V_I = 3.5$ V
Low Level Input Current	$I_{IL}$			-10	$\mu$ A	$V_I = 0.4$ V
Absolute  Short-circuit Output Current	$I_{OS}$	60		250	$\mu$ A	$-7$ V > $V_O$ < $12$ V
Supply Current ( $V_{DD2} = +5$ V)	$I_{DD2}$		5	8	mA	No Load (Outputs Enabled)
( $V_{DD1} = +5$ V)	$I_{DD1}$		4	6		
( $V_{DD1} = +3.3$ V)	$I_{DD1}$		3	4		
Switching Specifications						
Parameters	Symbol	Min.	Typ. <sup>(5)</sup>	Max.	Units	Test Conditions
Maximum Data Rate		40			Mbps	$R_L = 54 \Omega$ , $C_L = 50$ pF
Differential Output Prop Delay	$t_D(OD)$		20	30	ns	$R_L = 54 \Omega$ , $C_L = 50$ pF
Pulse Skew <sup>(10)</sup>	$t_S(P)$		1	6	ns	$R_L = 54 \Omega$ , $C_L = 50$ pF
Differential Output Rise & Fall Time	$t_r(OD)$		5	8	ns	$R_L = 54 \Omega$ , $C_L = 50$ pF
Output Enable Time To High Level	$t_{PZH}$		20	30	ns	$R_L = 54 \Omega$ , $C_L = 50$ pF
Output Enable Time To Low Level	$t_{PZL}$		20	30	ns	$R_L = 54 \Omega$ , $C_L = 50$ pF
Output Disable Time From High Level	$t_{PHZ}$		20	30	ns	$R_L = 54 \Omega$ , $C_L = 50$ pF
Output Disable Time From Low Level	$t_{PLZ}$		20	30	ns	$R_L = 54 \Omega$ , $C_L = 50$ pF
Skew Limit <sup>(3)</sup>	$t_{SK}(LIM)$		2	12	ns	$R_L = 54 \Omega$ , $C_L = 50$ pF

**Notes:** These apply to both driver and receiver sections

- All Voltage values are with respect to network ground except differential I/O bus voltages.
- Differential input/output voltage is measured at the noninverting terminal A with respect to the inverting terminal B.
- Skew limit is the maximum propagation delay difference between any two devices at 25°C.
- The power-off measurement in ANSI Standard EIA/TIA-422-B applies to disabled outputs only and is not applied to combined inputs and outputs.
- All typical values are at  $V_{DD1}, V_{DD2} = 5$  V or  $V_{DD1} = 3.3$  V and  $T_A = 25^\circ\text{C}$ .
- While  $-7$  V <  $V_{CM}$  <  $12$  V, the minimum  $V_{OD2}$  with a  $54 \Omega$  load is either  $\frac{1}{2} V_{OD1}$  or  $2.3$  V, whichever is greater.
- $\Delta|V_{OD}|$  and  $\Delta|V_{OC}|$  are the changes in magnitude of  $V_{OD}$  and  $V_{OC}$ , respectively, that occur when the input is changed from one logic state to the other.
- This applies for both power on and power off, refer to ANSI standard RS-485 for exact condition. The EIA/TIA-422-B limit does not apply for a combined driver and receiver terminal.
- Includes 10 ns read enable time. Maximum propagation delay is 25 ns after read assertion.
- Pulse skew is defined as the  $|t_{PLH} - t_{PHL}|$  of each channel.
- Absolute Maximum specifications mean the device will not be damaged if operated under these conditions. It does not guarantee performance.

## Receiver Section

Electrical Specifications are  $T_{min}$  to  $T_{max}$  unless otherwise stated.

Parameters	Symbol	Min.	Typ. <sup>(5)</sup>	Max.	Units	Test Conditions
Positive-going Input Threshold Voltage	$V_{IT+}$			0.2	V	$-7V > V_{CM} < 12V$
Negative-going Input Threshold Voltage	$V_{IT-}$	-0.2			V	$-7V > V_{CM} < 12V$
Hysteresis Voltage ( $V_{IT+} - V_{IT-}$ )	$V_{HYS}$		40		mV	$V_{CM} = 0V, T = 25^{\circ}C$
High Level Digital Output Voltage	$V_{OH}$	$V_{DD} - 0.2$	$V_{DD}$		V	$V_{ID} = 200mV$ $I_{OH} = -20\mu A$
Low Level Digital Output Voltage	$V_{OL}$			0.2	V	$V_{ID} = -200mV$ $I_{OH} = 20\mu A$
High-impedance-state output current	$I_{OZ}$			$\pm 1$	$\mu A$	$V_O = 0.4$ to ( $V_{DD2} - 0.5$ ) V
Line Input Current <sup>(8)</sup>	$I_I$			1	mA	$V_I = 12V$
				-0.8	mA	$V_I = -7V$
Input Resistance	$R_I$	20			k $\Omega$	
Supply Current ( $V_{DD2} = +5V$ )	$I_{DD2}$		5	8	mA	No load Outputs Enabled
( $V_{DD1} = +5V$ )	$I_{DD1}$		4	6		
( $V_{DD1} = +3.3V$ )	$I_{DD1}$		3	4		

### Switching Characteristics @ 5 V

Parameters	Symbol	Min.	Typ. <sup>(5)</sup>	Max.	Units	Test Conditions
Maximum Data Rate		40			Mbps	$R_L = 54\Omega, C_L = 50pF$
Propagation Delay <sup>(9)</sup>	$t_{PD}$		27	35	ns	$V_O = -1.5$ to $1.5V$ , $C_L = 15pF$
Pulse Skew <sup>(10)</sup>	$t_{SK}(P)$		1	6	ns	$V_O = -1.5$ to $1.5V$ , $C_L = 15pF$
Skew Limit <sup>(3)</sup>	$t_{SK}(LIM)$		2	12	ns	$R_L = 54\Omega, C_L = 50pF$
Output Enable Time To High Level	$t_{PZH}$		15	25	ns	$C_L = 15pF$
Output Enable Time To Low Level	$t_{PZL}$		15	25	ns	$C_L = 15pF$
Output Disable Time From High Level	$t_{PHZ}$		15	25	ns	$C_L = 15pF$
Output Disable Time From Low Level	$t_{PLZ}$		15	25	ns	$C_L = 15pF$

### Switching Characteristics @ 3.3 V

Parameters	Symbol	Min.	Typ. <sup>(5)</sup>	Max.	Units	Test Conditions
Maximum Data Rate		40			Mbps	$R_L = 54\Omega, C_L = 50pF$
Propagation Delay <sup>(9)</sup>	$t_{PD}$		30	38	ns	$V_O = -1.5$ to $1.5V$ , $C_L = 15pF$
Pulse Skew <sup>(10)</sup>	$t_{SK}(P)$		1	6	ns	$V_O = -1.5$ to $1.5V$ , $C_L = 15pF$
Skew Limit <sup>(3)</sup>	$t_{SK}(LIM)$		4	12	ns	$R_L = 54\Omega, C_L = 50pF$
Output Enable Time To High Level	$t_{PZH}$		17	27	ns	$C_L = 15pF$
Output Enable Time To Low Level	$t_{PZL}$		17	27	ns	$C_L = 15pF$
Output Disable Time From High Level	$t_{PHZ}$		17	27	ns	$C_L = 15pF$
Output Disable Time From Low Level	$t_{PLZ}$		17	27	ns	$C_L = 15pF$

## Power Consumption

Isoloop devices achieve their low power consumption by detecting the edge transitions of the input logic signal and converting these to narrow current pulses. This technique creates a supply current which is proportional to data rate, which has obvious advantages over optocouplers whose power consumption is dependent on mark:space ratio.

**Table 2. Typical Dynamic Supply Currents.**

Data Rate (Mbps)	I <sub>DD1</sub>	I <sub>DD2</sub>
1	300 $\mu$ A	300 $\mu$ A
10	3 mA	3 mA
20	6 mA	6 mA
40	12 mA	12 mA

## Power Supplies

It is required that low ESR capacitors such as ceramic are used to decouple the supplies. Both V<sub>DD1</sub> and V<sub>DD2</sub> must be bypassed with 47 nF capacitors. These should be placed as close as possible to V<sub>DD</sub> pins for proper operation. In addition, V<sub>DD2</sub> should have a 10  $\mu$ F tantalum capacitor connected in parallel with the 47 nF capacitor.

## DC Correctness

The IL3585 incorporates a patented refresh circuit which effectively maintains the correct output state with respect to data input. At power up, the bus outputs will follow the Function Table shown on Page 1. It is recommended that the DE input is always held low during power up to eliminate false drive data pulses from the bus. The use of an external power supply monitor to minimize glitches caused by slow power-up and power-down transients is not required.

## Application Information

### Receiver Features

The IL3585 receiver includes a “fail-safe if open” function that guarantees a high level receiver output if the receiver inputs are unconnected (floating). IL3585 receiver outputs have tri-state capability via the active low RE input.

### Driver Features

The RS-485 driver is a differential output device that delivers at least 1.5 V across a 54  $\Omega$  load. The drivers feature low propagation delay skew to maximize bit width and to minimize EMI. The IL3585 drivers have tri-state capability via the active high DE input.

### Receiver Data Rate, Cables and Terminations

This device is intended for network lengths up to 4000', but the maximum system data rate decreases as the transmission line length increases. Twisted pair cable should be used in all networks since they tend to pick up noise and other electromagnetically induced voltages as common mode signals, which are effectively rejected by the differential receivers in these ICs.

## IL3585 (0.3" SOIC-16 Package)

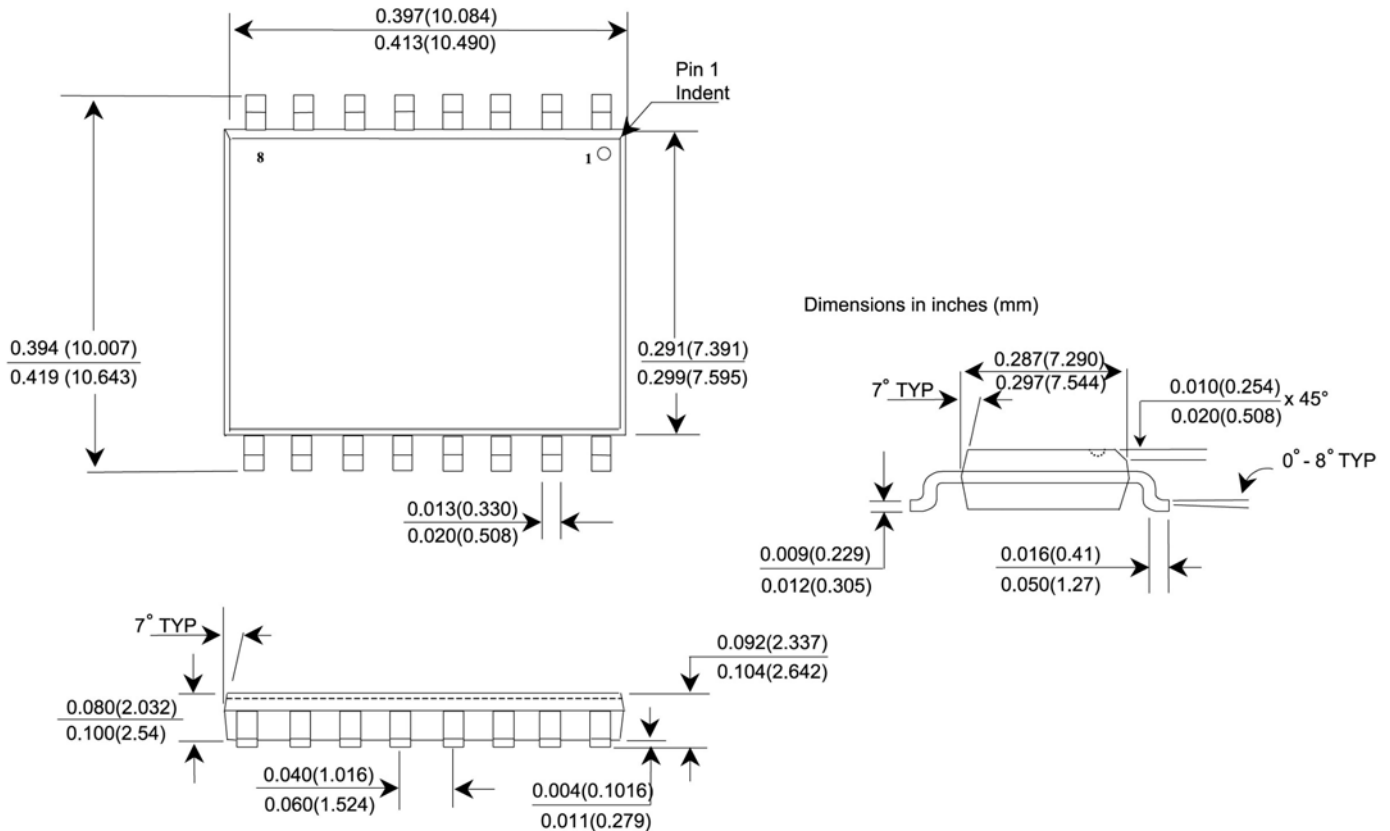

## Ordering Information and Valid part Numbers

### IL 3585 E TR13

- **Bulk Package**  
Blank = Tube  
TR13 = 13" Tape and Reel
- **Lead Frame Material**  
Blank = Tin-Lead Plating  
E = 100% Tin (Pb Free)
- **Base Part Number**  
3585 = RS485 Transceiver
- **Product Family**  
IL = Isolators

### Valid Part Numbers

IL3585  
IL3585E  
IL3585TR13  
IL3585E TR13

## About NVE

An ISO 9001 Certified Company

NVE Corporation is a high technology components manufacturer having the unique capability to combine leading edge Giant Magnetoresistive (GMR) materials with integrated circuits to make high performance electronic components. Products include Magnetic Field Sensors, Magnetic Field Gradient Sensors (Gradiometer), Digital Magnetic Field Sensors, Digital Signal Isolators and Isolated Bus Transceivers.

NVE is a leader in GMR research and in 1994 introduced the world's first products using GMR material, a line of GMR magnetic field sensors that can be used for position, magnetic media, wheel speed and current sensing.

NVE is located in Eden Prairie, Minnesota, a suburb of Minneapolis. Please visit our Web site at [www.nve.com](http://www.nve.com) or call 952-829-9217 for information on products, sales or distribution.

NVE Corporation  
11409 Valley View Road  
Eden Prairie, MN 55344-3617 USA  
Telephone: (952) 829-9217  
Fax: (952) 829-9189  
Internet: [www.nve.com](http://www.nve.com)  
e-mail: [isoinfo@nve.com](mailto:isoinfo@nve.com)

*The information provided by NVE Corporation is believed to be accurate. However, no responsibility is assumed by NVE Corporation for its use, nor for any infringement of patents, nor rights or licenses granted to third parties, which may result from its use. No license is granted by implication, or otherwise, under any patent or patent rights of NVE Corporation. NVE Corporation does not authorize, nor warrant, any NVE Corporation product for use in life support devices or systems or other critical applications. The use of NVE Corporation's products in such applications is understood to be entirely at the customer's own risk.*

**Specifications shown are subject to change without notice.**

ISB-DS-001-IL3585-B

January 26, 2005