

TRIPLE 3-INPUT OR GATE

FEATURES

- Output capability: standard
- I_{CC} category: SSI

GENERAL DESCRIPTION

The 74HC/HCT4075 are high-speed Si-gate CMOS devices and are pin compatible with the "4075" of the "4000B" series. They are specified in compliance with JEDEC standard no. 7A. The 74HC/HCT4075 provide the 3-input OR function.

SYMBOL	PARAMETER	CONDITIONS	TYPICAL		UNIT
			HC	HCT	
t _{PHL} / t _{PLH}	propagation delay nA, nB, nC to nY	C _L = 15 pF V _{CC} = 5 V	8	10	ns
C _I	input capacitance		3.5	3.5	pF
C _{PD}	power dissipation capacitance per gate	notes 1 and 2	28	32	pF

GND = 0 V; T_{amb} = 25 °C; t_r = t_f = 6 ns

Notes

1. P_D is used to determine the dynamic power dissipation (P_D in μW):

$$P_D = C_{PD} \times V_{CC}^2 \times f_i + \sum (C_L \times V_{CC}^2 \times f_o) \text{ where:}$$

f_i = input frequency in MHz C_L = output load capacitance in pF
 f_o = output frequency in MHz V_{CC} = supply voltage in V
 ∑ (C_L × V_{CC}² × f_o) = sum of outputs

2. For HC the condition is V_I = GND to V_{CC}
 For HCT the condition is V_I = GND to V_{CC} - 1.5 V

PACKAGE OUTLINES

14-lead DIL; plastic (SOT27).
 14-lead mini-pack; plastic (SO14; SOT108A).

PIN DESCRIPTION

PIN NO.	SYMBOL	NAME AND FUNCTION
3, 1, 11	1A to 3A	data inputs
4, 2, 12	1B to 3B	data inputs
5, 8, 13	1C to 3C	data inputs
6, 9, 10	1Y to 3Y	data outputs
7	GND	ground (0 V)
14	V _{CC}	positive supply voltage

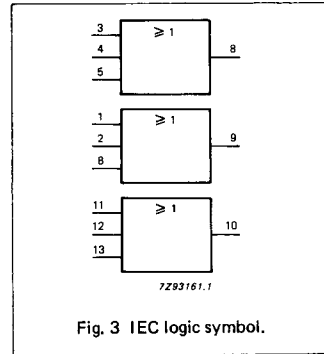
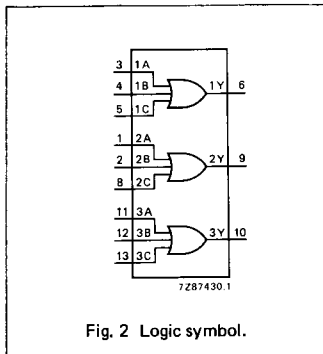
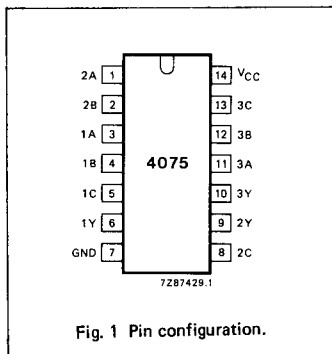

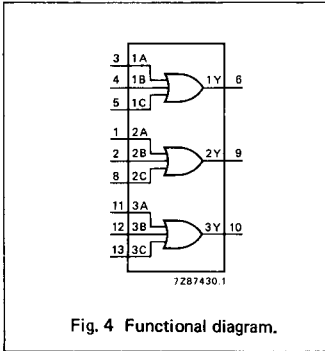

Fig. 4 Functional diagram.

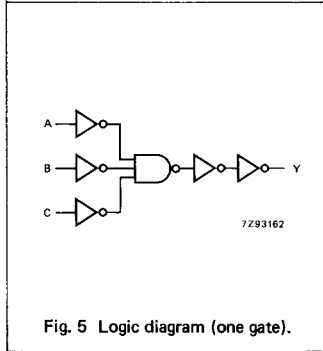

Fig. 5 Logic diagram (one gate).

FUNCTION TABLE

INPUTS			OUTPUT
nA	nB	nC	nY
L	L	L	L
H	X	X	H
X	H	X	H
X	X	H	H

H = HIGH voltage level
L = LOW voltage level
X = don't care

DC CHARACTERISTICS FOR 74HC

For the DC characteristics see chapter "HCMOS family characteristics", section "Family specifications".

Output capability: standard
I_{CC} category: SSI

AC CHARACTERISTICS FOR 74HC

GND = 0 V; t_r = t_f = 6 ns; C_L = 50 pF

SYMBOL	PARAMETER	T _{amb} (°C)						UNIT	TEST CONDITIONS		
		74HC							V _{CC} V	WAVEFORMS	
		+25			-40 to +85		-40 to +125				
		min.	typ.	max.	min.	max.	min.				max.
t _{PHL} / t _{PLH}	propagation delay nA, nB, nC to nY		28 10 8	100 20 17		125 25 21		150 30 26	ns	2.0 4.5 6.0	Fig. 6
t _{THL} / t _{TLH}	output transition time		19 7 6	75 15 13		95 19 16		110 22 19	ns	2.0 4.5 6.0	Fig. 6

DC CHARACTERISTICS FOR 74HCT

For the DC characteristics see chapter "HCMOS family characteristics", section "Family specifications".

Output capability: standard

I_{CC} category: SSI

Note to HCT types

The value of additional quiescent supply current (ΔI_{CC}) for a unit load of 1 is given in the family specifications. To determine ΔI_{CC} per input, multiply this value by the unit load coefficient shown in the table below.

INPUT	UNIT LOAD COEFFICIENT
nA, nB, nC	1.50

AC CHARACTERISTICS FOR 74HCT

GND = 0 V; t_r = t_f = 6 ns; C_L = 50 pF

SYMBOL	PARAMETER	T _{amb} (°C)						UNIT	TEST CONDITIONS		
		74HCT							V _{CC} V	WAVEFORMS	
		+25			-40 to +85		-40 to +125				
		min.	typ.	max.	min.	max.	min.		max.		
t _{PHL} / t _{PLH}	propagation delay nA, nB, nC to nY		12	24		30		36	ns	4.5	Fig. 6
t _{THL} / t _{TLH}	output transition time		7	15		19		22	ns	4.5	Fig. 6

AC WAVEFORMS

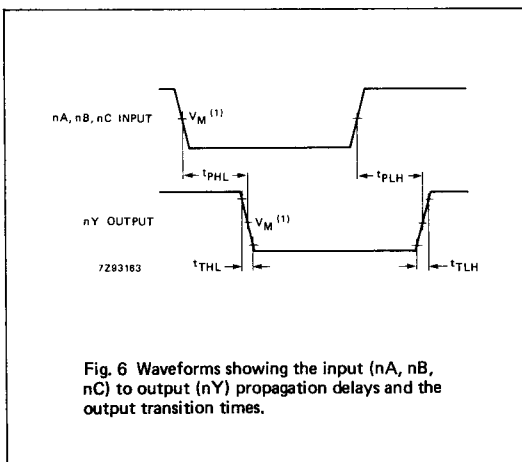

Fig. 6 Waveforms showing the input (nA, nB, nC) to output (nY) propagation delays and the output transition times.

Note to AC waveforms

(1) HC : V_M = 50%; V_I = GND to V_{CC}.
HCT: V_M = 1.3 V; V_I = GND to 3 V.