

40V, 1.7A, Boost for 10 White LED Driver

❖ GENERAL DESCRIPTION

The AX2016/A is a step-up converter designed for driving up to 10 series white LEDs for backlighting application. The AX2016/A uses current mode, 1MHz fixed frequency architecture to regulate the LED current, which is set through an external current sense resistor. Its low 300mV feedback voltage reduces power loss and improves efficiency. The OV pin monitors the output voltage and turns off the converter if an over-voltage condition is present due to an open circuit condition. The AX2016/A includes under-voltage lockout, current limiting and thermal shutdown protection preventing damage in the event of an output overload. The driver is available in small 6-pin TSOT-23 and 8-pin TDFN (2mm x 2mm) packages.

❖ FEATURES

- 2.5V to 5.5V operating input voltage range
- Drives up to 10 series White LEDs
- 1MHz Fixed Switching Frequency
- Wide range for PWM dimming (200Hz to 200KHz)
- Internal 1.7A switching current limit
- Over Voltage Protection (OVP)
- Internal Soft-start Function
- Current limit and Thermal shutdown protection
- Under voltage Lockout
- Available in the 6-pin TSOT-23 and 8-pin TDFN Packages

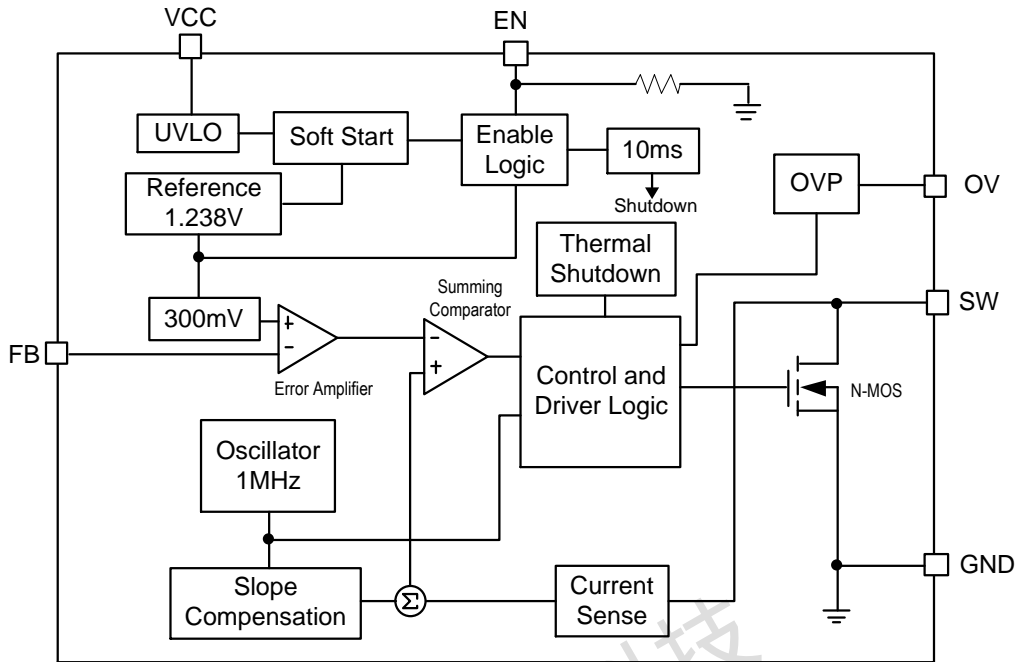
❖ BLOCK DIAGRAM

❖ PIN ASSIGNMENT

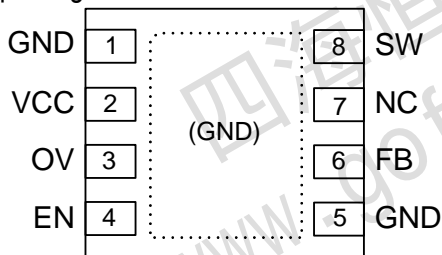
The packages of AX2016/A are TSOT-23-6L and TDFN-8L; the pin assignment is given by:

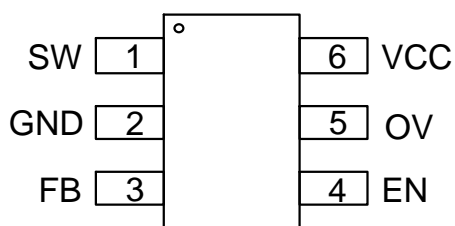

TDFN-8L (2*2)

(Top View)



TSOT-23-6L

Name	Description
GND	Ground Pin
VCC	Power Input Pin
OV	OVP Sense Pin
EN	Enable with Dimming Pin; Internal Pull-Low; Logic High Active
FB	Feedback Pin; Put a Resistor to GND to Setting the Current
NC	No Connect Pin
SW	Switch Output Pin

❖ ELECTRICAL CHARACTERISTICS

 ($V_{CC}=5V$, $I_{OUT} = 20mA$, $T_A = 25^{\circ}C$, unless otherwise noted)

Characteristics		Symbol	Conditions	Min	Typ	Max	Units
Input Voltage Range		V_{CC}		2.5	-	5.5	V
Step-Up Voltage Range		V_{OUT}		3	-	40	V
OV Sense Voltage		V_{OV}			38		V
Under Voltage Lockout		U_{VLO}	Rising	-	2.2	2.4	V
UVLO Hysteresis				-	100	-	mV
Feedback Voltage	AX2016	V_{FB}		285	300	315	mV
	AX2016A	V_{FB}		190	200	210	mV
EN Threshold	Logic-High Voltage	V_{IH}		2.0	-	-	V
	Logic-Low Voltage	V_{IL}		-	-	0.4	V
EN Hysteresis				-	200	-	mV
Operating Quiescent Current		I_{CCQ}	$I_{OUT}= 0mA$, $V_{FB} =0.5V$	-	300	500	μA
Shutdown Current		I_{SD}	$V_{EN}=0V$, $t_{EN} > 20ms$	-	1	4	μA
N-Channel MOSFET Current Limit (Note1)		I_{LIM}	Duty=50%		1.7	-	A
MOSFET On-Resistance (Note1)		$R_{DS(on)}$		-	0.6	1.0	Ω
Maximum Duty Cycle		D_{MAX}		-	88	-	%
Line Regulation			$V_{CC} = 3V$ to $5V$	-	1	-	%
Switching Frequency		F_{OSC}		0.75	1	1.25	MHz
Dimming Clock Rate		F_{DIM}		0.2	-	200	KHz
FB Input Leakage Current		I_{FB-LKG}	$V_{FB} = 0.5V$	-	0.01	100	nA
SW Leakage Current		I_{SWL}	$V_{LX} = 30V$, $V_{FB} =0.5V$	-	-	1	μA
EN Input Leakage Current	$I_{EN-LKG1}$	$V_{EN}= V_{CC}$		-	1.5	3	μA
	$I_{EN-LKG2}$	$V_{EN}= GND$		-	-	1	μA
Shutdown Delay		T_{SHDN}		-	10	-	mS
Thermal Shutdown		T_{SD}		-	160	-	$^{\circ}C$
Thermal Shutdown Hysteresis		T_{SH}		-	30	-	

Note1: Guaranteed by design.

❖ APPLICATION CIRCUIT

(1) 10 series LED application

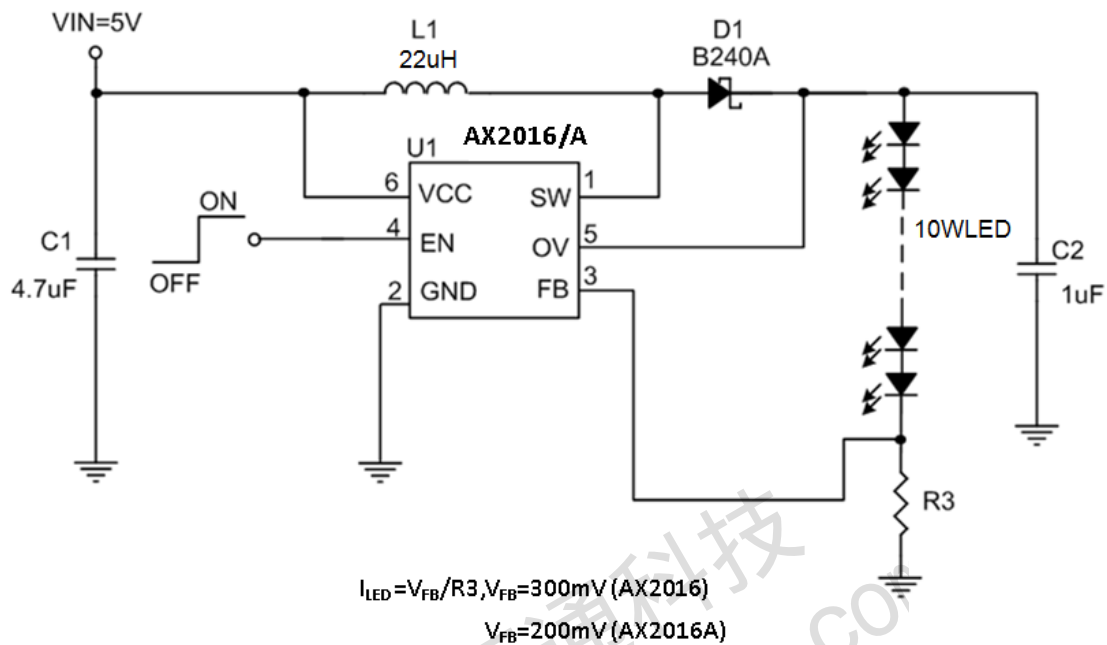

(2) LED Dimming application

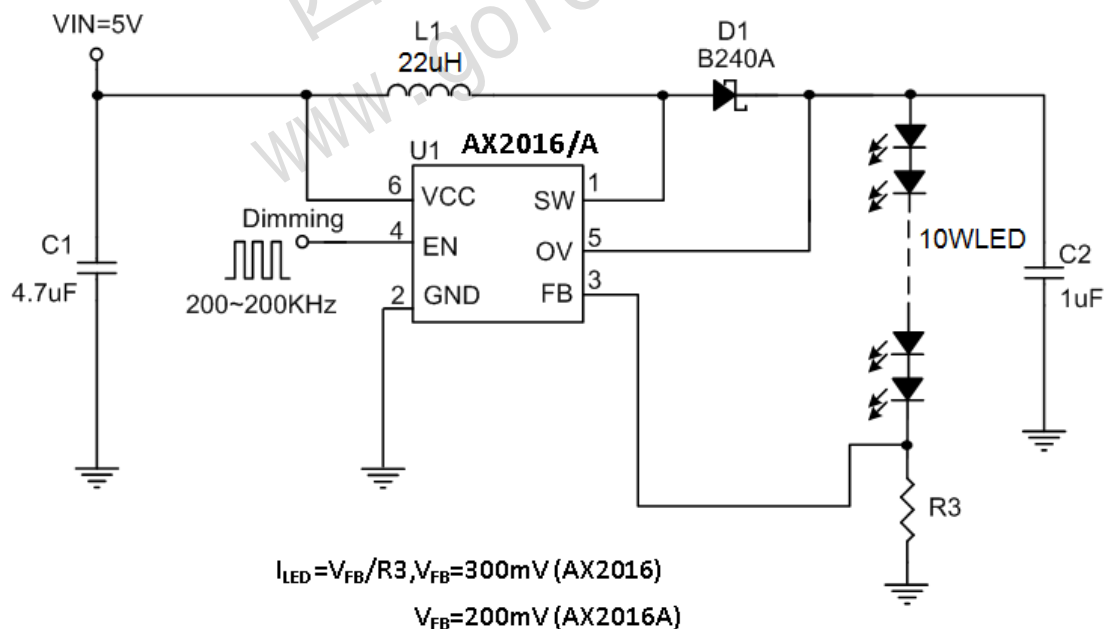

❖ APPLICATION INFORMATION

Setting the I_{LED} Current

Application circuit item shows the basic application circuit with AX2016/A adjustable output version. The external resistor sets the LED output current according to the following equation:

$$I_{LED} = (V_{FB} / R3)$$

Part No.	I _{LED}	R3	
AX2016	20mA	15Ω	6mW
	350mA	0.857Ω	105mW
AX2016A	20mA	10Ω	4mW
	350mA	0.571Ω	70mW

Over Voltage Protection

The Over Voltage Protection is detected by a junction breakdown detecting circuit. Once V_{OUT} goes over the detecting voltage, SW pin stops switching and the power N-MOSFET will be turned off. Then, the V_{OUT} will be clamped to be near V_{OVP}.

Under Voltage Lockout (UVLO)

To avoid mis-operation of the device at low input voltages an under voltage lockout is included that disables the device, if the input voltage falls below (2.25V-100mV).

Input Capacitor Selection

The input capacitor reduces the surge current drawn from the input and switching noise from the device. The input capacitor impedance at the switching frequency shall be less than input source impedance to prevent high frequency switching current passing to the input. A low ESR input capacitor sized for maximum RMS current must be used. Ceramic capacitors with X5R or X7R dielectrics are highly recommended because of their low ESR and small temperature coefficients. A 4.7μF ceramic capacitor for most applications is sufficient. For a lower output power requirement application, this value can be decreased.

Output Capacitor Selection

The output capacitor is required to keep the output voltage ripple small and to ensure regulation loop stability. The output capacitor must have low impedance at the switching frequency. Ceramic capacitors with X5R or X7R dielectrics are recommended due to their low ESR and high ripple current. A 1uF ceramic capacitors works for most of the applications. Higher capacitor values can be used to improve the load transient response.

❖ TYPICAL CHARACTERISTICS

Efficiency vs. Output Current

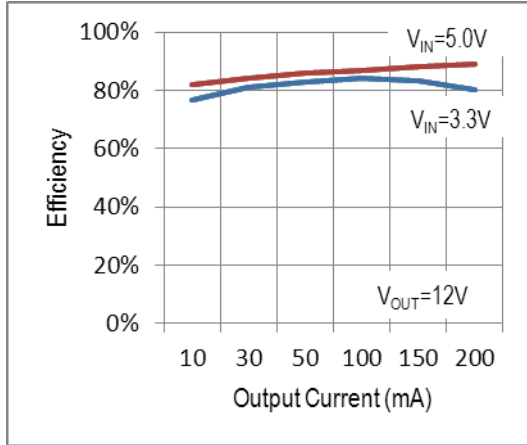

Efficiency vs. Input Voltage

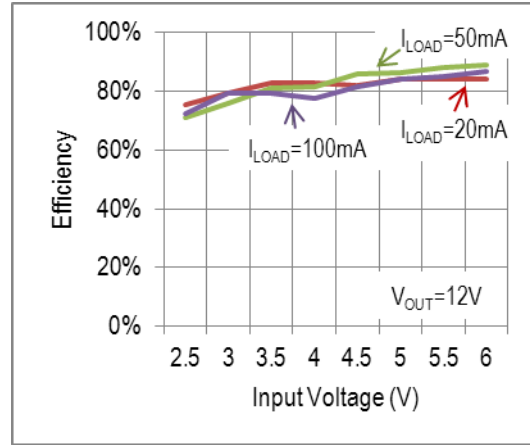

Output Voltage vs. Output Current

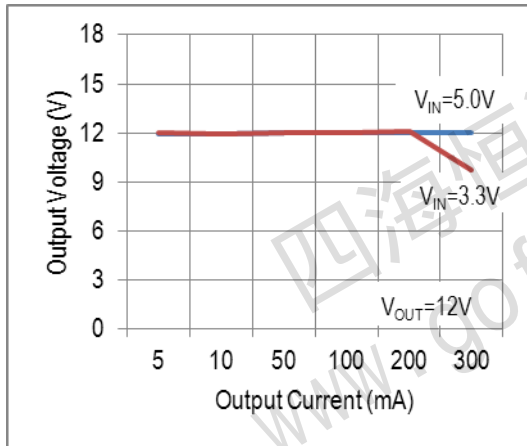

Quiescent Current vs. Input Voltage

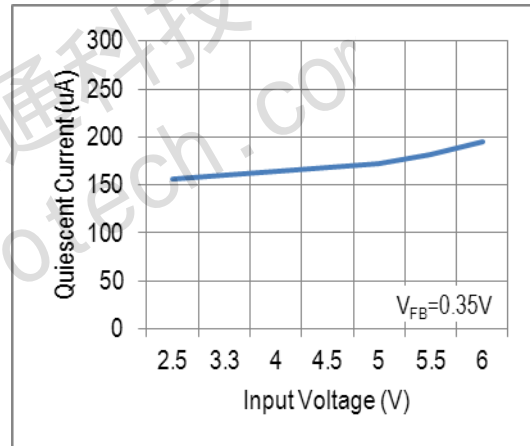

Frequency vs. Input Voltage

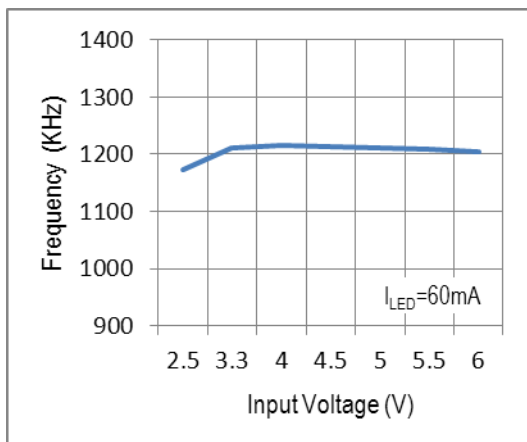

Frequency vs. Temperature

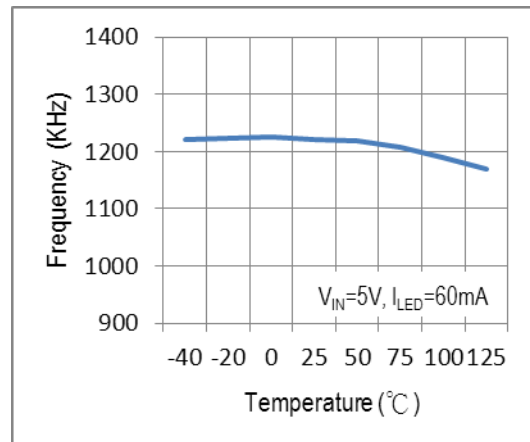

❖ TYPICAL CHARACTERISTICS (CONTINUOUS)

Reference Voltage vs. Input Voltage

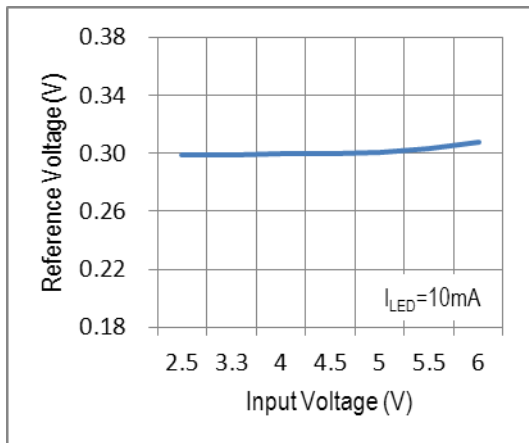

Reference Voltage vs. Temperature

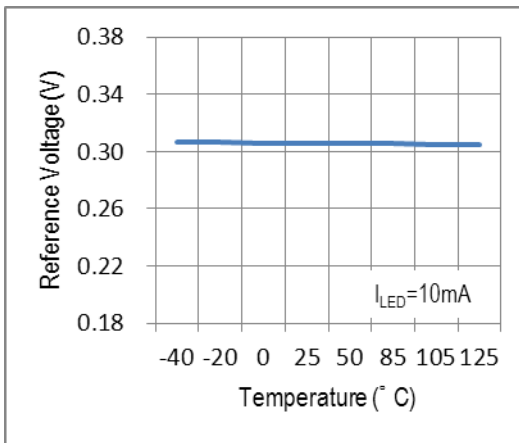

LED Current vs. Duty

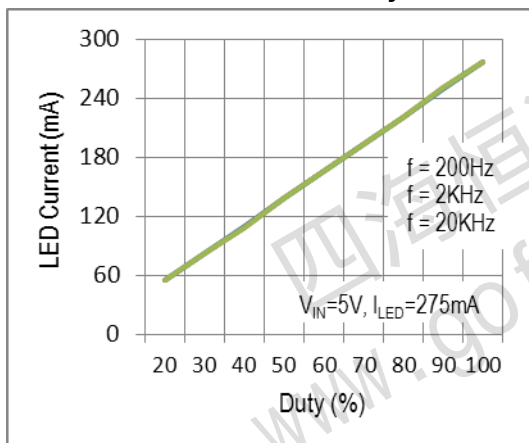

Enable Threshold vs. Input Voltage

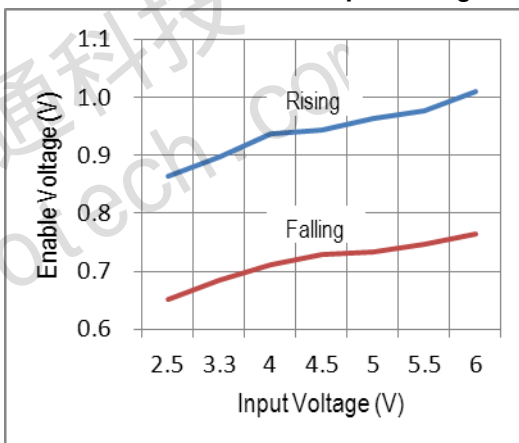

❖ TYPICAL CHARACTERISTICS (CONTINUOUS)

Power ON from V_{IN}

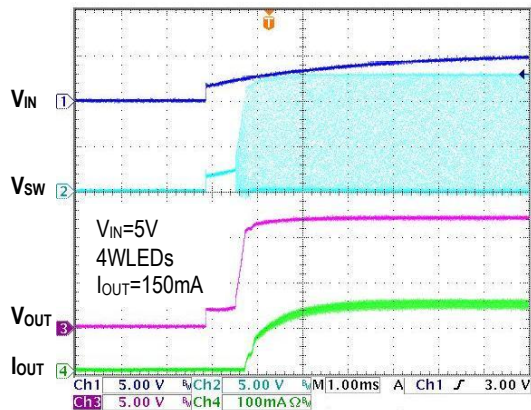

Power ON from EN

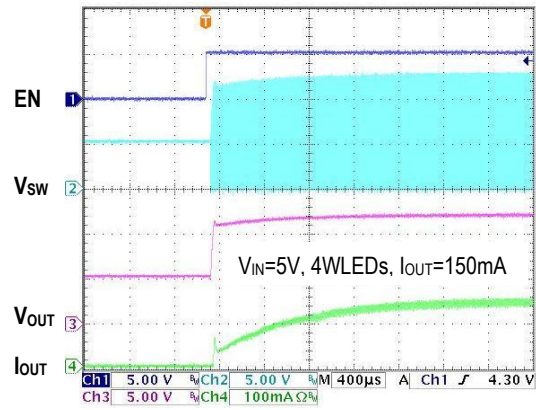

Steady State Operation

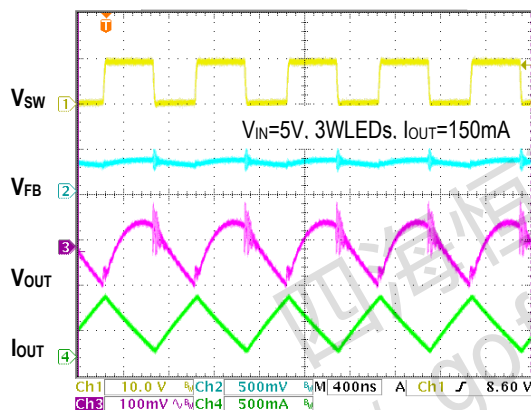

Normal Operation into OVP

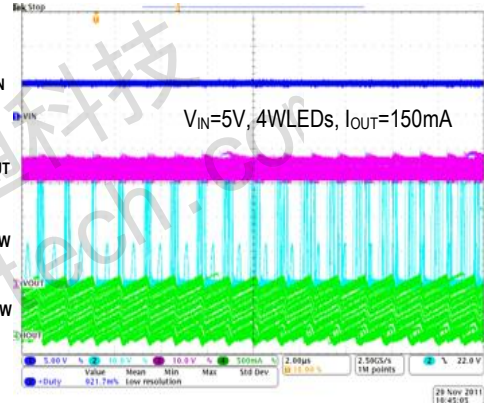

(V_{OUT} , I_{OUT} : measured by AC coupled mode)

PWM Dimming from EN (200Hz)

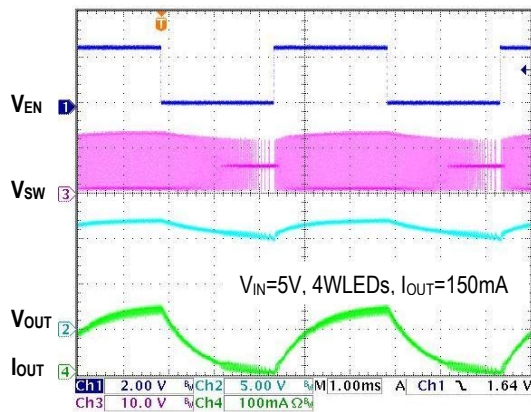

PWM Dimming from EN (20KHz)

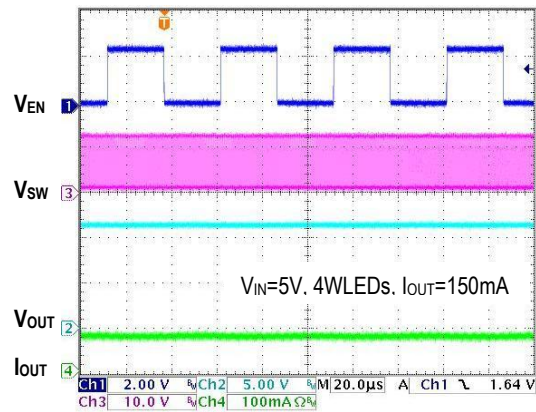

❖ PACKAGE OUTLINES

(1) TSOT-23-6L

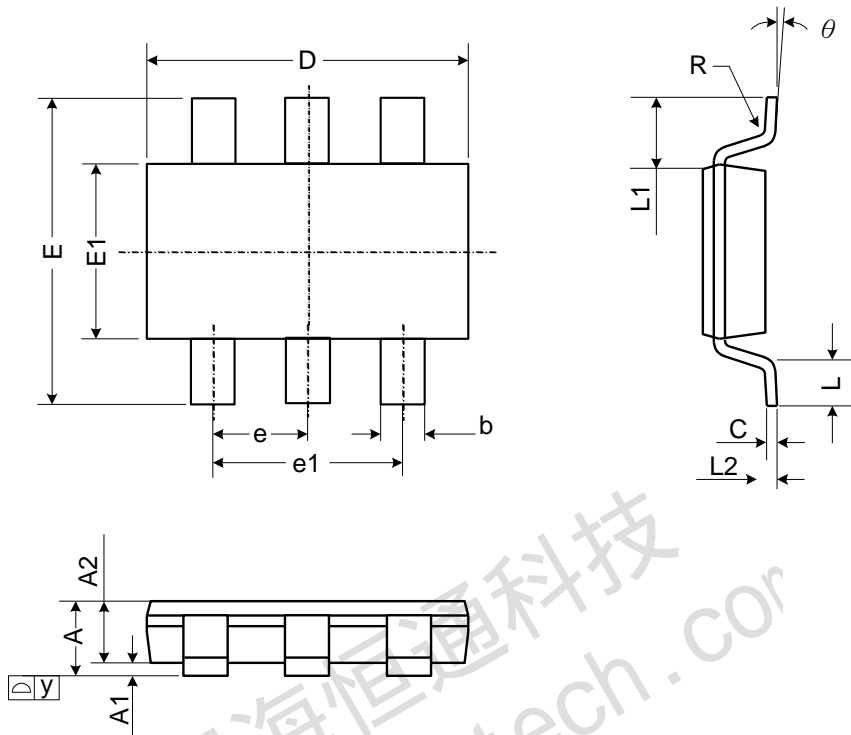

Symbol	Dimensions in Millimeters			Dimensions in Inches		
	Min.	Nom.	Max.	Min.	Nom.	Max.
A	-	-	1.10	-	-	0.043
A1	0.00	-	0.10	0	-	0.004
A2	0.70	0.90	1.00	0.028	0.035	0.039
b	0.30	0.40	0.50	0.012	0.016	0.020
C	0.08	0.14	0.20	0.003	0.006	0.008
D	2.80	2.90	3.00	0.110	0.114	0.118
E	2.60	2.80	3.00	0.102	0.110	0.118
E1	1.50	1.60	1.70	0.059	0.063	0.067
e	0.95 BSC.			0.037 BSC.		
e1	1.90 BSC.			0.075 BSC.		
L	0.30	0.45	0.60	0.012	0.018	0.024
L1	0.60 REF.			0.024 REF.		
L2	0.25 BSC.			0.010 BSC.		
y	-	-	0.10	-	-	0.004
R	0.10	-	-	0.004	-	-
θ	0°	-	8°	0°	-	8°

JEDEC outline: MO-193 AA

(2) TDFN-8L (2*2 0.75mm)

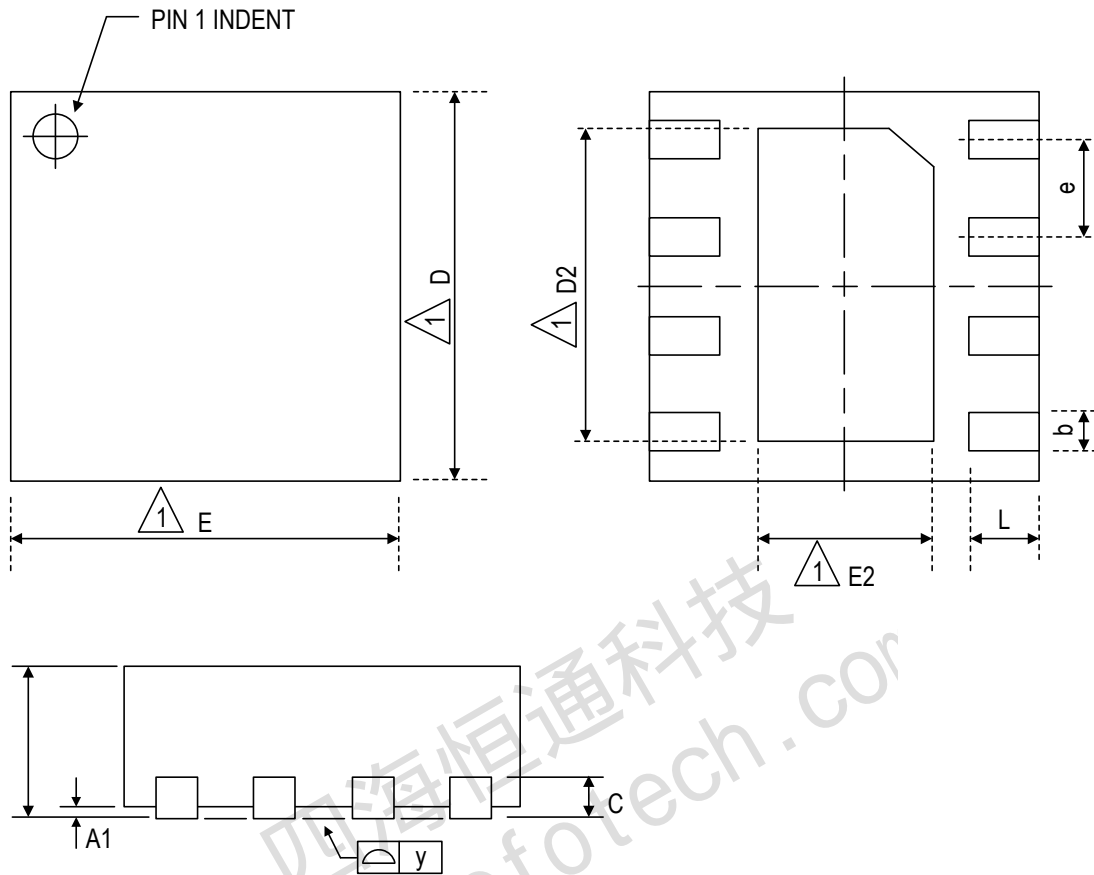

Symbol	Dimensions in Millimeters			Dimensions in Inches		
	Min.	Nom.	Max.	Min.	Nom.	Max.
A	0.70	0.75	0.80	0.028	0.03	0.031
A1	0.00	0.02	0.05	0.00	0.001	0.002
b	0.15	0.20	0.25	0.006	0.008	0.01
C	0.19	0.20	0.25	0.007	0.008	0.01
D	1.90	2.00	2.10	0.075	0.079	0.082
D2	1.00	1.60	1.65	0.061	0.063	0.065
E	1.90	2.00	2.10	0.075	0.079	0.082
E2	0.40	0.90	0.95	0.033	0.035	0.037
e	-	0.50	-	-	0.02	-
L	0.20	0.35	0.45	0.012	0.014	0.016
y	0.00	-	0.08	0.00	-	0.003