

# HT9261

## Description

The HT9261 Series are PFM step-up DC-DC converters with very low ripple noise due to the high operation frequency. The maximum operation frequency is 300KHz.

Only three components are required to realize the conversion from the battery voltage to a selected output voltage.

A driver pin (EXT) is provided for driving external power transistor to extend the output current capability where large current is required.

Enable pin (EN) is also provided so that the circuit can be powered down.

## Features

- ◆ 300KHz Maximum Operation Frequency
- ◆ 2.0V to 5.0V Output Voltage with 0.1V step
- ◆ Low Start-up Voltage: 0.8V at 1mA
- ◆  $\pm 2.5\%$  Output Voltage Accuracy
- ◆ Up to 88% Efficiency
- ◆ Output current: 300mA at 2.5V input, 3.3V output
- ◆ Low Ripple and Low Noise
- ◆ Output current extendable by External Switch

## Applications

- Power source for applications where a higher voltage than the battery voltage is required
- One to three cell battery devices
- Power source for cameras, camcorders, VCRs, PDAs, papers and hand held communication instrument

## Block Diagram

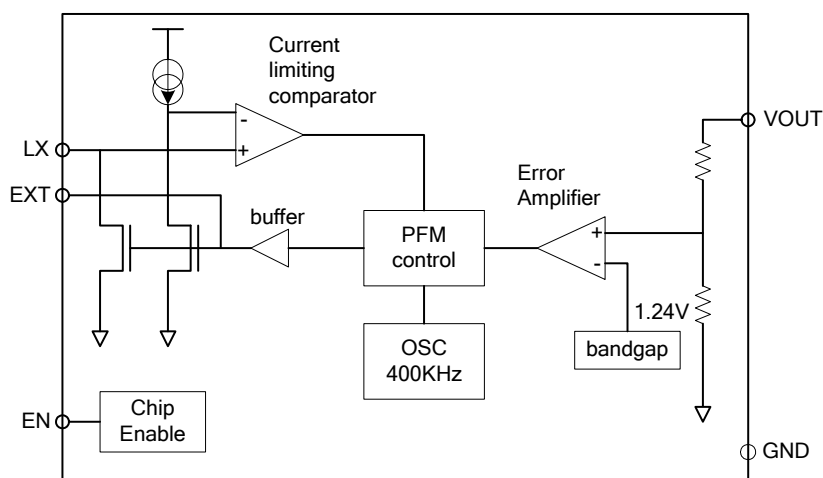

Ordering Information

# HT9261

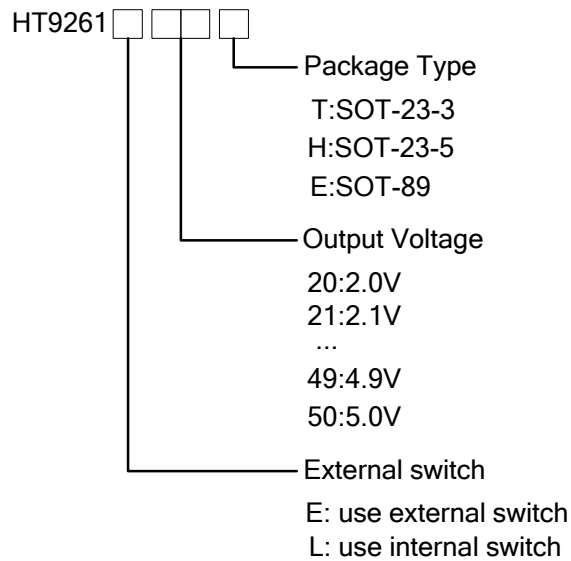

Pin Configuration (Top View)

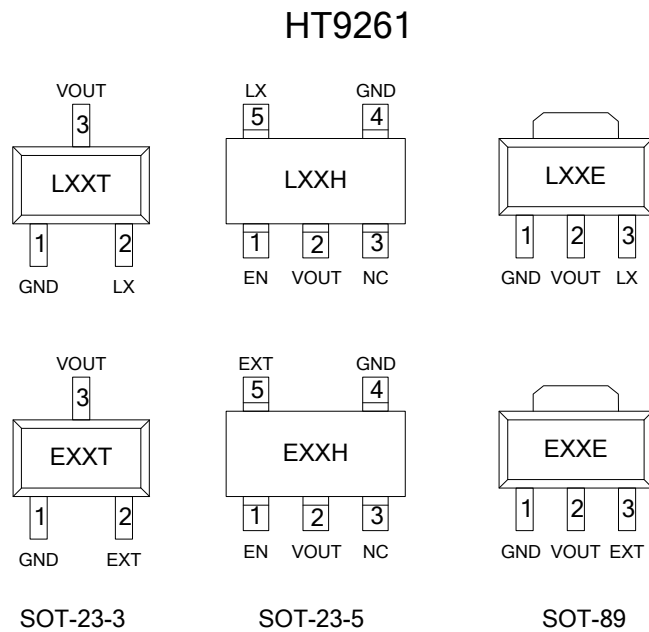

# HT9261

## Pin Description

Part Marking and Package Type						Pin Name	Pin Function
HT9261							
LXXT SOT-23-3	LXXH SOT-23-5	LXXE SOT-89	EXXT SOT-23-3	EXXH SOT-23-5	EXXE SOT-89		
2	5	3	-	-	-	LX	Switching pin
-	-	-	2	5	3	EXT	Buffer output for external transistor
3	2	2	3	2	2	VOUT	Output voltage
-	1	-	-	1	-	EN	Chip enable (active high)
1	4	1	1	4	1	GND	Ground
-	3	-	-	3	-	NC	No connection

## Absolute Maximum Ratings

Type	Symbol	Description	Value	Unit
Voltage	Vmax	Maximum voltage on VOUT and VLX pins	8	V
	Vmin-max	Voltage range on EXT and EN pins	-0.3~VOUT+0.3	
Current	ILXmax	Maximum current on LX pin	1000	mA
	IEXTmax	Maximum current on EXT pin	100	
Power dissipation	Psot-23-3	Maximum power dissipation for SOT-23-3	0.25	W
	Psot-23-5	Maximum power dissipation for SOT-23-5	0.25	
	Psot-89	Maximum power dissipation for SOT-89	0.5	
Thermal	Tmin-max	Operation temperature range	-20~85	°C
	Tstorage	Storage temperature range	-40~165	
ESD	VESD	ESD voltage for human body mode	2000	V

# HT9261

## Electronic Characteristics

Parameter	Symbol	Test Condition	Min	Typ	Max	Unit
Output Voltage accuracy	$\Delta V_{OUT}$		-2.5		2.5	%
Maximum input voltage	$V_{IN_{MAX}}$		0.7		$V_{OUT}$	V
Start-up voltage	$V_{START}$	$I_{LOAD}=1mA, V_{IN}:0 \rightarrow 2V$			0.85	V
Hold-on voltage	$V_{HOLD}$	$I_{LOAD}=1mA, V_{IN}:0 \rightarrow 2V$	0.6			V
Maximum oscillation frequency	$F_{MAX}$		200	250	300	KHz
Oscillator duty cycle	$DC_{OSC}$		75	80	85	%
Efficiency	$\eta$			85	88	%
Current limit	$I_{LIMIT}$		600	800	1000	mA
Input current at no load	$I_{IN0}$	$V_{IN}=1.8V, V_{OUT}=3.0V$			20	$\mu A$
		$V_{IN}=1.8V, V_{OUT}=5.0V$				$\mu A$
VOUT pin current at switch off	$I_{OUT0}$	Drive VOUT pin with voltage $V_{OUT}+0.5V$		6	8	$\mu A$
Input standby current	$I_{INQ}$	No load, EN="low"			1	$\mu A$
EN "High" voltage level			$0.4 * V_{OUT}$			V
EN "Low" level					0.2	V
EN "High" input current					0.1	$\mu A$
EN "low" input current			-0.1			$\mu A$
EXT output current			-5		5	mA

## Typical Characteristics (using internal switch transistor)

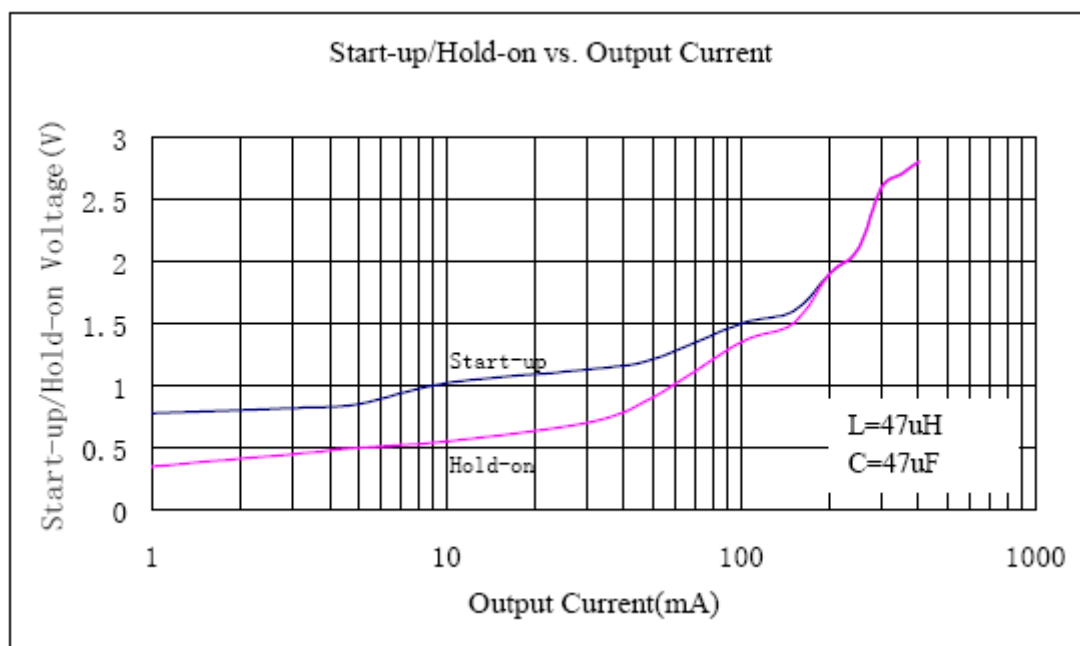

# HT9261

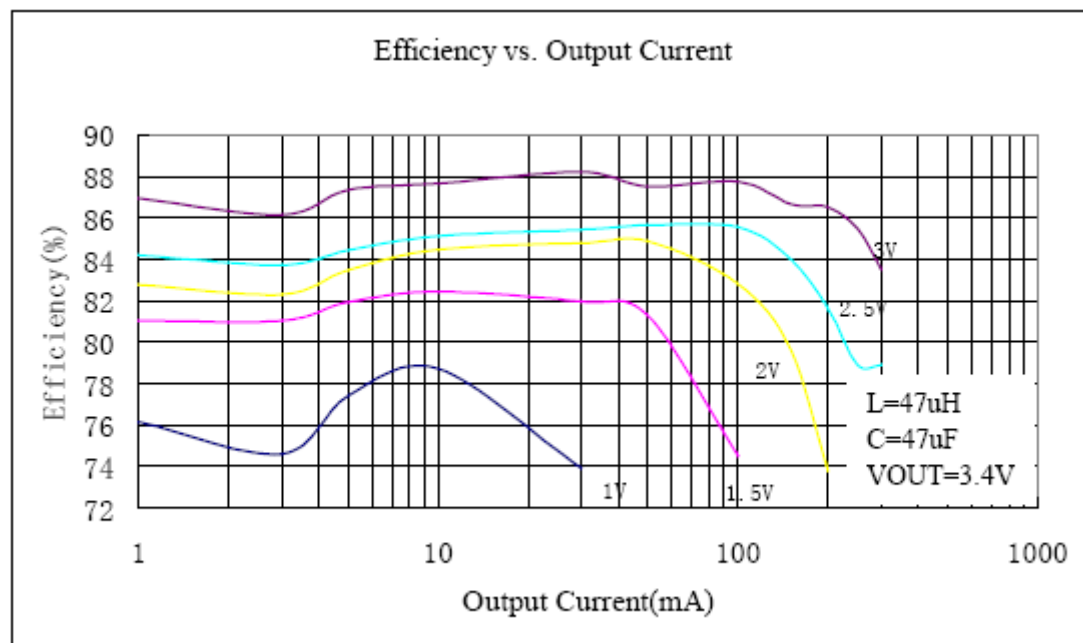
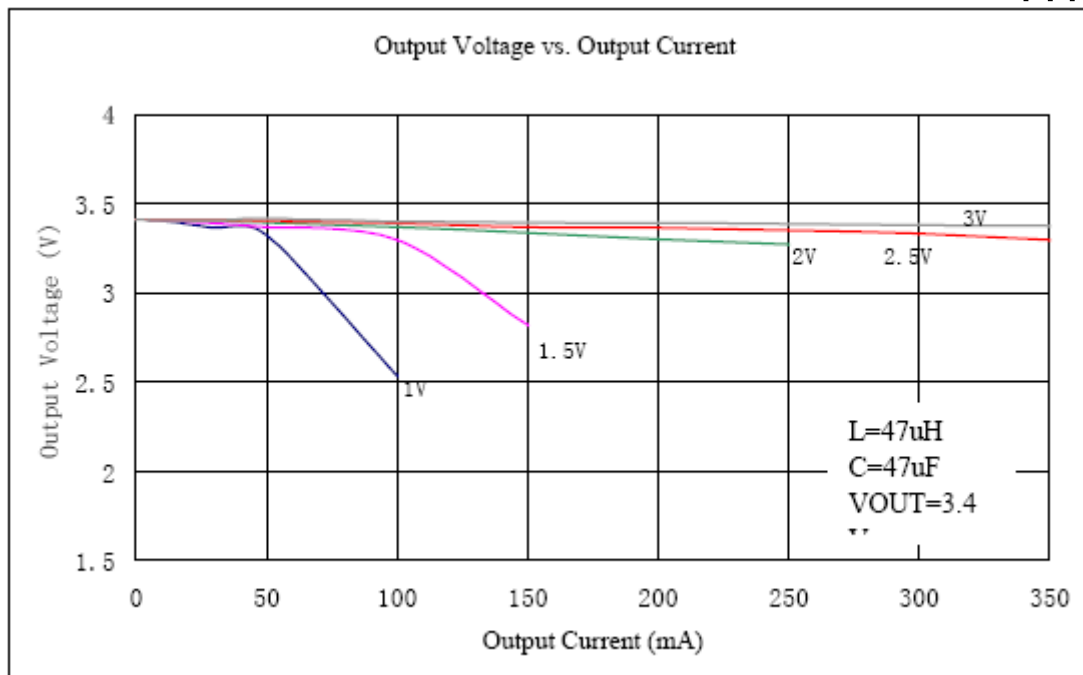

# HT9261

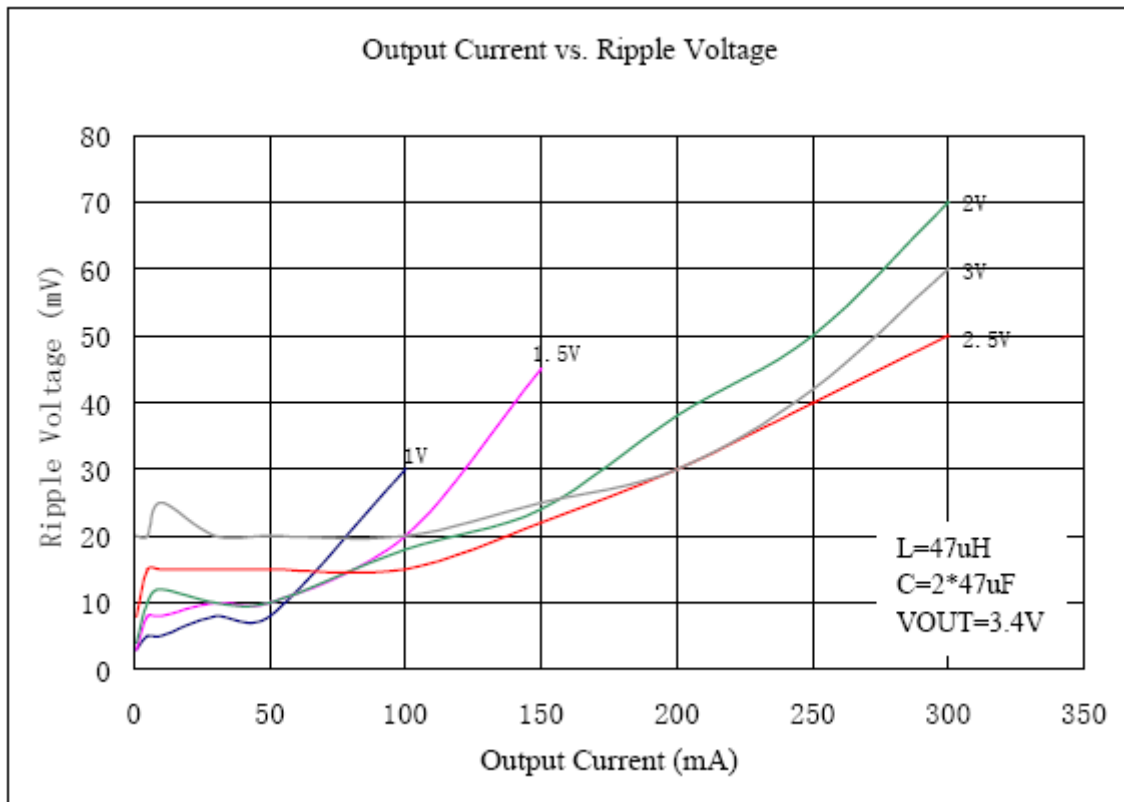
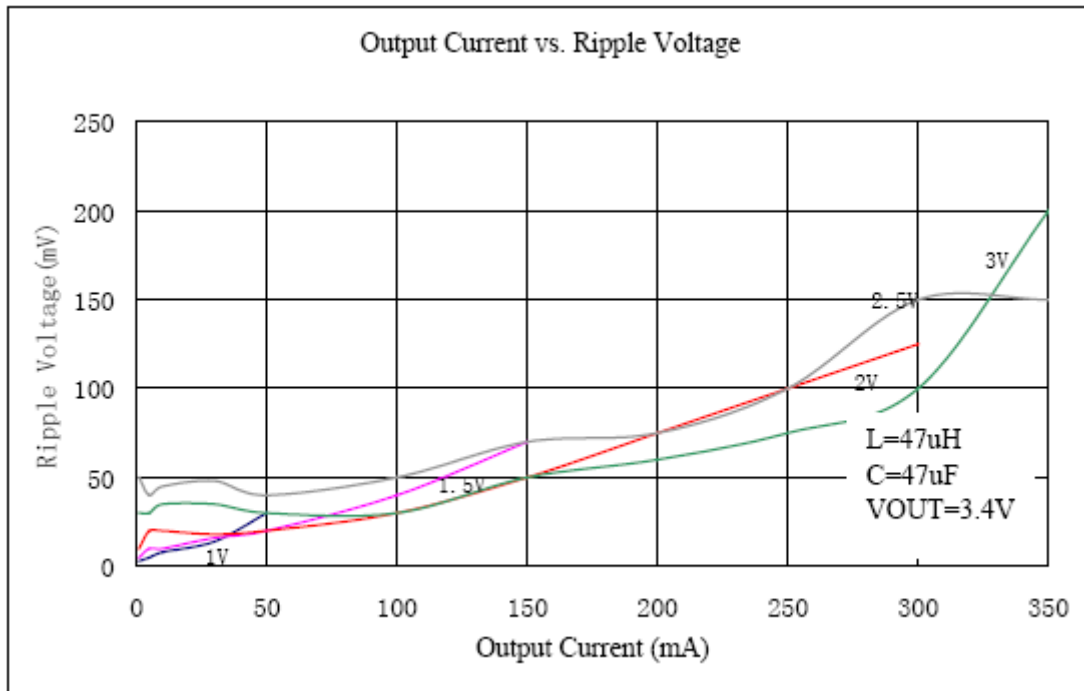

# HT9261

## Typical Applications

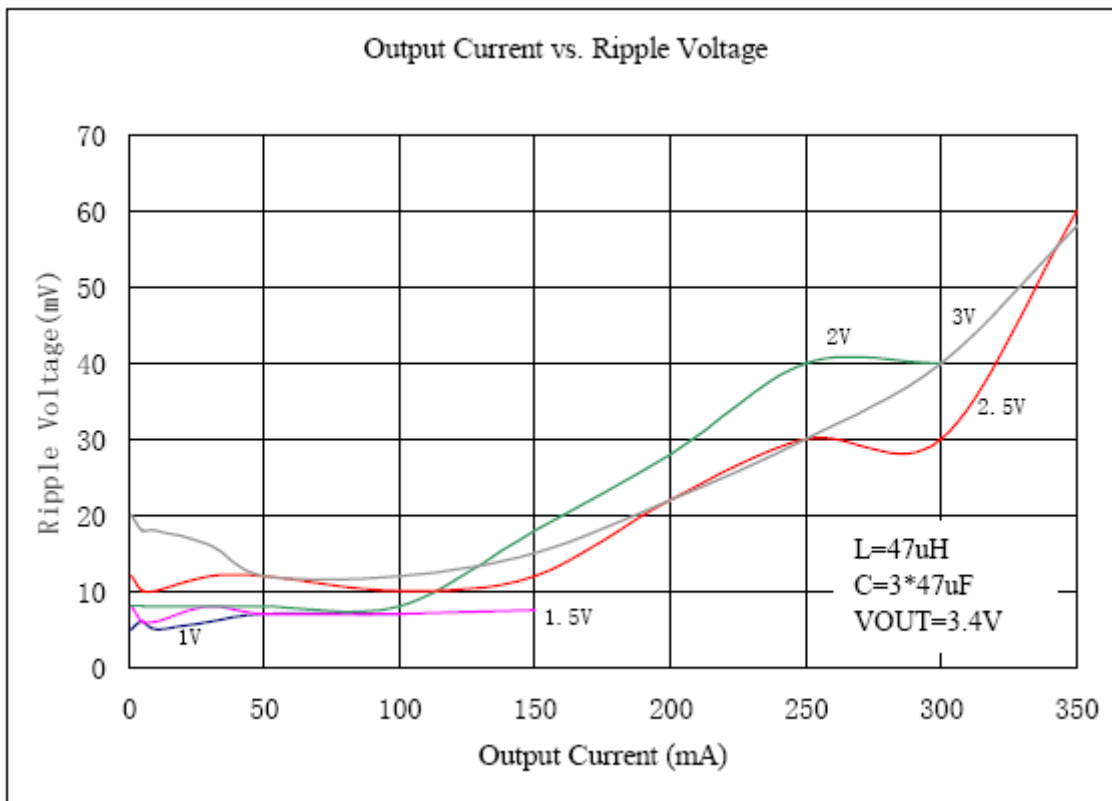

## Typical Applications

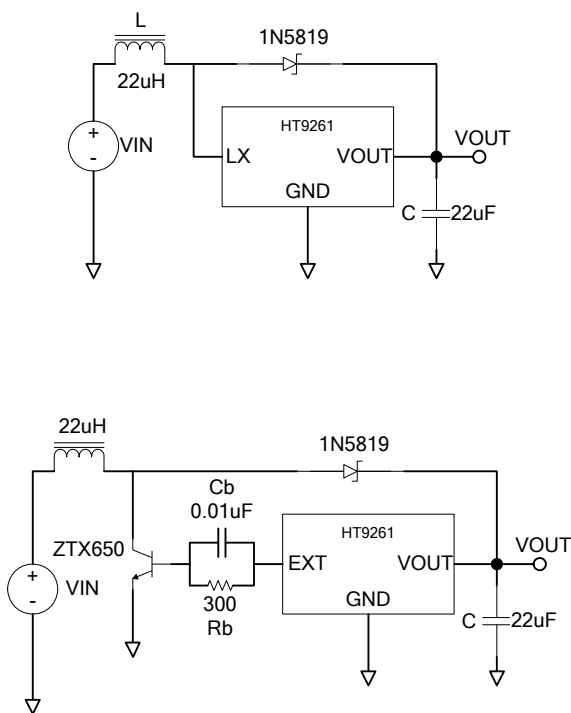

## Package

SOT- 23-3L package outline dimensions

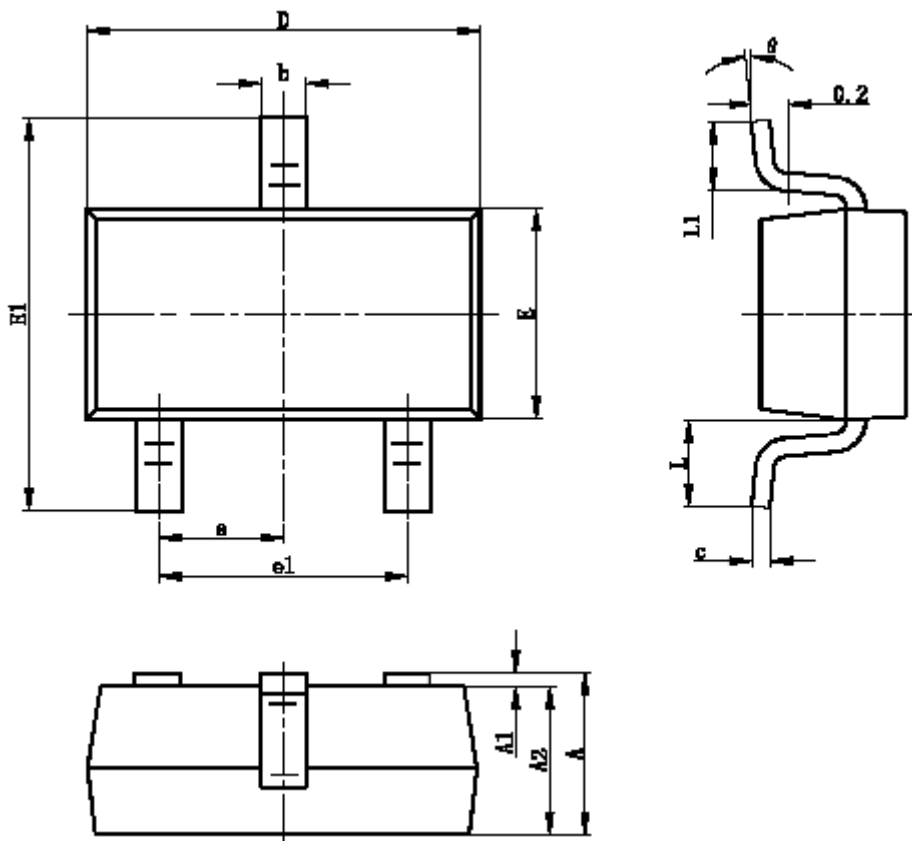

Symbol	Dimensions In Millimeters		Dimensions In Inches	
	Min	Max	Min	Max
A	1.050	1.250	0.041	0.049
A1	0.000	0.100	0.000	0.004
A2	1.050	1.150	0.041	0.045
B	0.300	0.400	0.012	0.016
c	0.100	0.200	0.004	0.008
D	2.820	3.020	0.111	0.119
E	1.500	1.700	0.059	0.067
E1	2.650	2.950	0.104	0.116
e	0.950TYP		0.037TYP	
e1	1.800	2.000	0.071	0.079
L	0.700REF		0.028REF	
L1	0.300	0.600	0.012	0.024
θ	0°	8°	0°	8°



SOT-23-5L Package outline dimensions

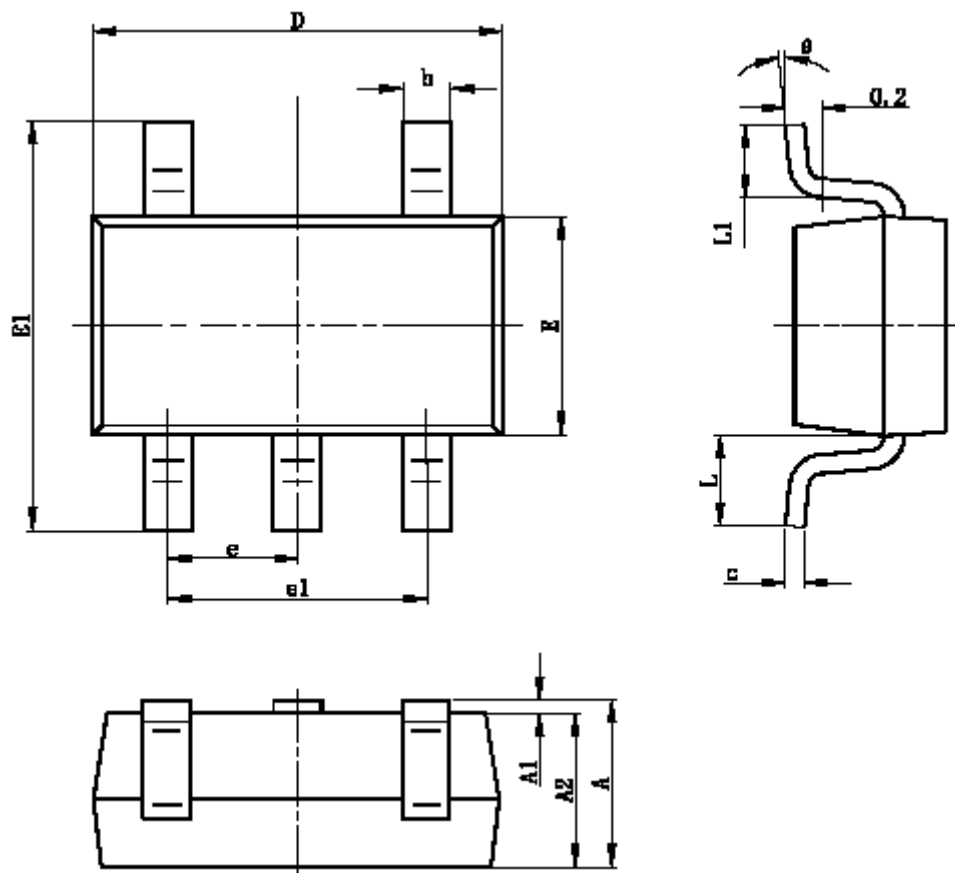

Symbol	Dimensions In Millimeters		Dimensions In Inches	
	Min	Max	Min	Max
A	1.050	1.250	0.041	0.049
A1	0.000	0.100	0.000	0.004
A2	1.050	1.150	0.041	0.045
b	0.300	0.400	0.012	0.016
c	0.100	0.200	0.004	0.008
D	2.820	3.020	0.111	0.119
E	1.500	1.700	0.059	0.067
E1	2.650	2.950	0.104	0.116
e	0.950TYP		0.037TYP	
e1	1.800	2.000	0.071	0.079
L	0.700TYP		0.028TYP	
L1	0.300	0.600	0.012	0.024
θ	0°	8°	0°	8°

## SOT-89-3L package outline dimensions

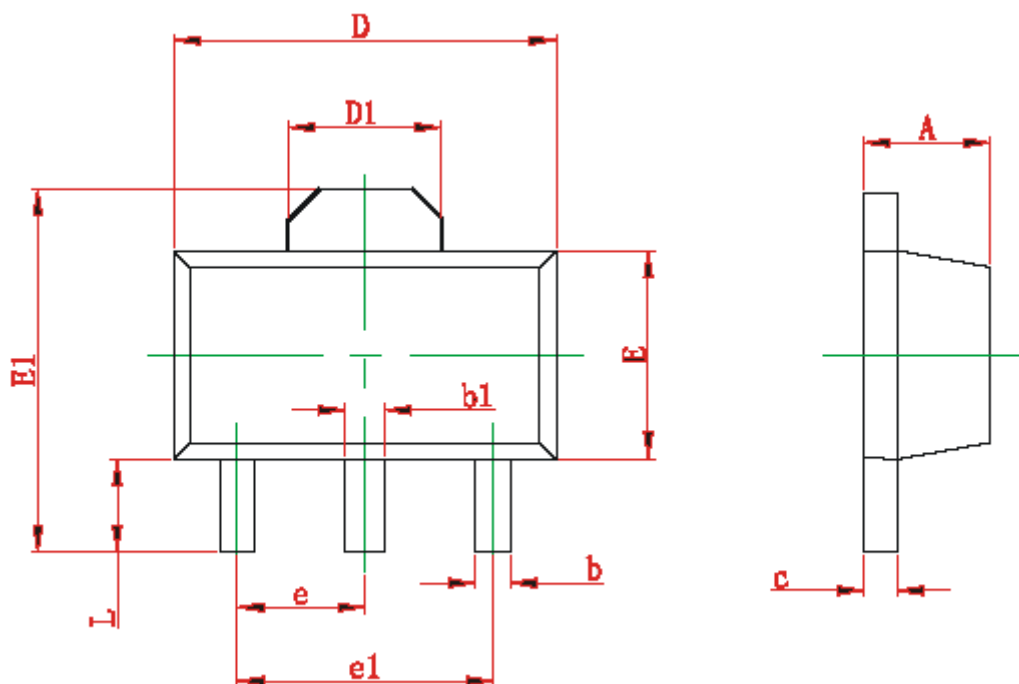

Symbol	Dimensions In Millimeters		Dimensions In Inches	
	Min	Max	Min	Max
A	1.400	1.600	0.055	0.063
b	0.320	0.520	0.013	0.197
b1	0.400	0.580	0.016	0.023
c	0.350	0.440	0.014	0.017
D	4.400	4.600	0.173	0.181
D1	1.550REF		0.061REF	
E	2.300	2.600	0.091	0.102
E1	3.940	4.250	0.155	0.167
e	1.500TYP		0.060TYP	
e1	3.000TYP		0.118TYP	
L	0.900	1.200	0.035	0.047