

### Features

- \* Meet ROHS
- \* Extra Thin (0.50Hmm) Full Color SMD Chip LED.
- \* Ultra Bright InGaN / AlInGaP Chip LED
- \* Package In 8mm Tape On 7" Diameter Reels.
- \* EIA STD Package.
- \* I.C. Compatible.
- \* Compatible With Automatic Placement Equipment.
- \* Compatible With Infrared Reflow Solder Process.

### Package Dimensions

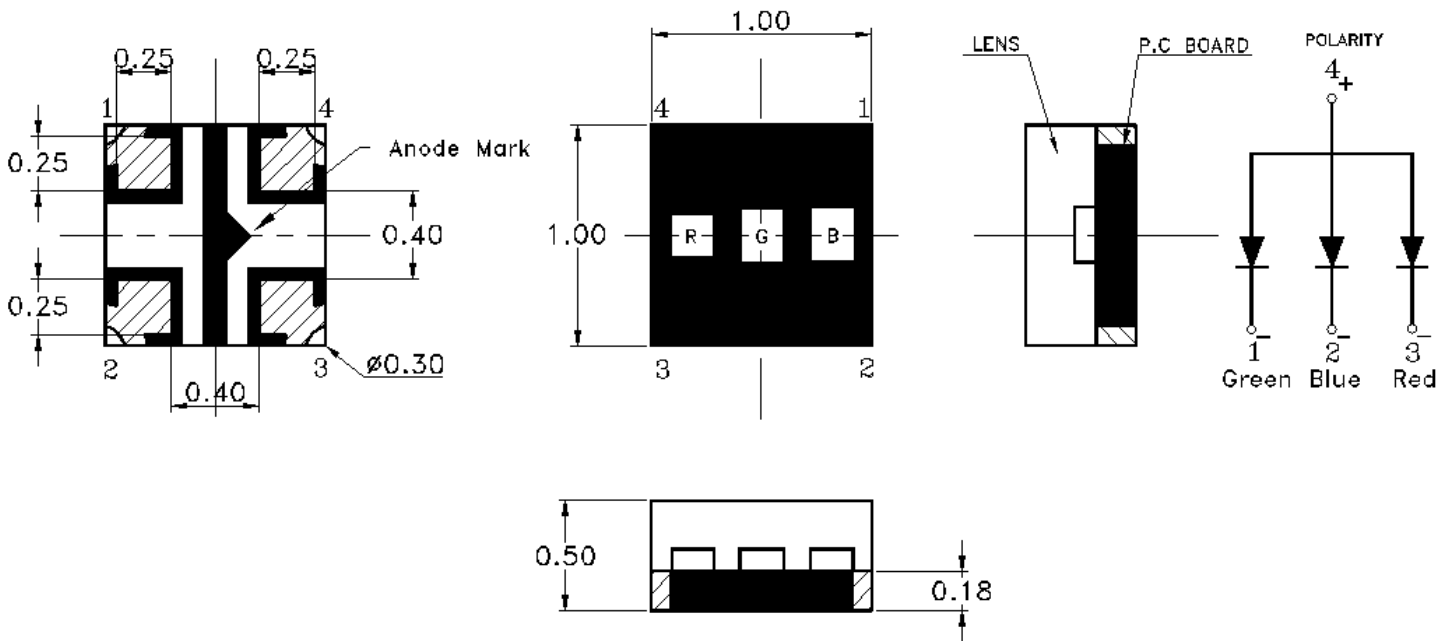

Part no.	Lens	Source Color	Pin Assignment
LTSN-B28JBGEW	White Diffused	InGaN Green	1
		InGaN Blue	2
		AlInGaP Red	3

### Notes:

1. All dimensions are in millimeters (inches).
2. Tolerance is  $\pm 0.10$  mm (.004") unless otherwise noted.

## Property of Lite-On Only

### Absolute Maximum Ratings At Ta=25°C

Parameter	LTSN-B28JBGEW			Unit
	Blue	Green	Red	
Power Dissipation	80	80	65	mW
Peak Forward Current (1/10 Duty Cycle, 0.1ms Pulse Width)	100	100	60	mA
DC forward current	20	20	25	mA
Operating Temperature Range	-30°C to + 85°C			
Storage Temperature Range	-40°C to + 85°C			
Infrared Soldering Condition	260°C For 10 Seconds			

**Suggestion Profile:**

Suggestion IR Reflow Profile For Pb Free Process

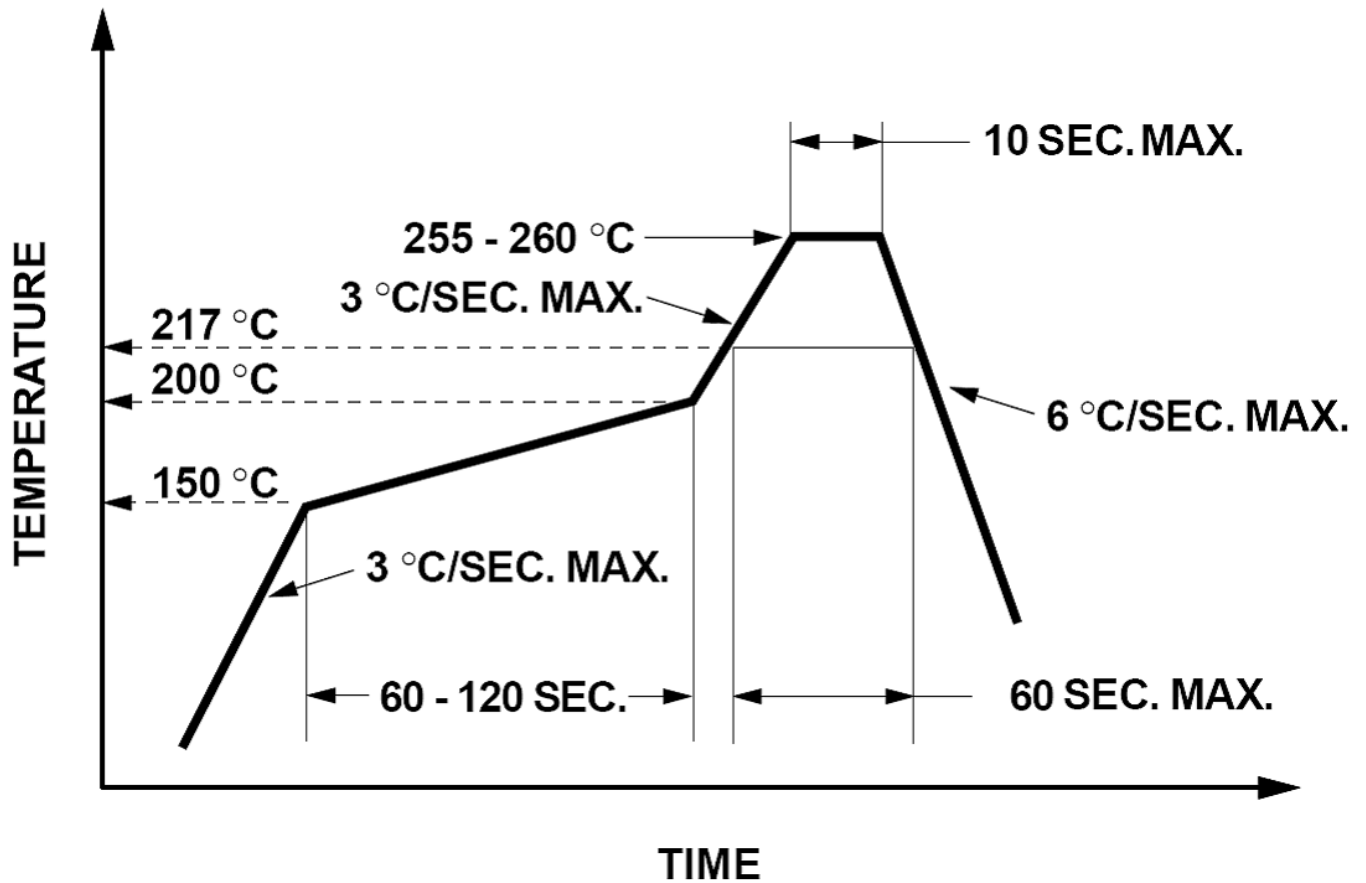

## Property of Lite-On Only

### Electrical Optical Characteristics At Ta=25°C

Parameter	Symbol		LTSN-B28JBGEW			Unit	Test Condition
			Blue	Green	Red		
Luminous Intensity	IV	MIN.	50.0	216.0	86.0	mcd	IF = 20mA Note 1
		TYP.	-	-	-		
		MAX.	125.0	450.0	216.0		
Viewing Angle	2θ1/2	TYP.	130			deg	Note 2 (Fig.5)
Peak Emission Wavelength	λPeak	TYP.	468.0	520.0	632.0	nm	Measurement @Peak (Fig.1)
Dominant Wavelength	λd	MIN.	466.0	519.0	619.0	nm	IF = 20mA Note 3
		MAX.	473.5	529.0	628.0		
Spectral Line Half-Width	Δλ	TYP.	25	35	20	nm	
Forward Voltage	VF	MIN.	2.70	2.70	1.80	V	IF = 20mA
		TYP.	-	-	-		
		MAX.	3.90	3.90	2.40		
Reverse Current	IR	MAX.	10	10	10	μA	VR = 5V Note 5

- Notes: 1. Luminous intensity is measured with a light sensor and filter combination that approximates the CIE eye-response curve.
2. θ1/2 is the off-axis angle at which the luminous intensity is half the axial luminous intensity.
3. The dominant wavelength, λd is derived from the CIE chromaticity diagram and represents the single wavelength which defines the color of the device.
4. Caution in ESD:  
Static Electricity and surge damages the LED. It is recommend to use a wrist band or anti-electrostatic glove when handling the LED. All devices, equipment and machinery must be properly grounded.
5. Reverse voltage (VR) condition is applied to IR test only. The device is not designed for reverse operation.

## Property of Lite-On Only

### Bin Code List

Luminous Intensity		Color : <u>Blue</u> , Unit : mcd @20mA	
Bin Code	Min.	Max.	
F1	50.0	60.0	
F2	60.0	72.0	
G1	72.0	86.0	
G2	86.0	104.0	
H1	104.0	125.0	

Tolerance on each Intensity bin is +/-15%

Luminous Intensity		Color : <u>Green</u> , Unit : mcd @20mA	
Bin Code	Min.	Max.	
K1	216.0	260.0	
K2	260.0	312.0	
L1	312.0	375.0	
L2	375.0	450.0	

Tolerance on each Intensity bin is +/-15%

Luminous Intensity		Color : <u>Red</u> , Unit : mcd @20mA	
Bin Code	Bin Code	Bin Code	
G2	86.0	104.0	
H1	104.0	125.0	
H2	125.0	150.0	
J1	150.0	180.0	
J2	180.0	216.0	

Tolerance on each Intensity bin is +/-15%

## Property of Lite-On Only

### Bin Code List

Dominant Wavelength		Color : <u>Blue</u> , Unit : nm @20 mA	
AC1	466.0	468.5	
AC2	468.5	471.0	
AD1	471.0	473.5	

Tolerance for each Dominate Wavelength bin is +/- 1nm

Dominant Wavelength		Color : <u>Green</u> , Unit : nm @20 mA	
AN2	519.0	521.5	
AP1	521.5	524.0	
AP2	524.0	526.5	
AQ	526.5	529.0	

Tolerance for each Dominate Wavelength bin is +/- 1nm

Dominant Wavelength		Color : <u>Red</u> , Unit : nm @20 mA	
U	619.0	622.0	
V	622.0	625.0	
W	625.0	628.0	

Tolerance for each Dominate Wavelength bin is +/- 1nm

## Bin Code on Tag Cross Table

Luminous Intensity							Unit : mcd @ 20mA			
Bin Code On Tag	Blue		Green		Red					
	Code	Range	Code	Range	Code	Range				
A1	F1	50-60	K1	216-260	G2	86-104				
A2					H1	104-125				
A3					H2	125-150				
A4					J1	150-180				
A5					J2	180-216				
A6			K2	260-312			G2	86-104		
A7							H1	104-125		
A8							H2	125-150		
A9							J1	150-180		
A10							J2	180-216		
A11			L1	312-375			G2	86-104		
A12							H1	104-125		
A13							H2	125-150		
A14							J1	150-180		
A15							J2	180-216		
A16			L2	375-450			G2	86-104		
A17							H1	104-125		
A18							H2	125-150		
A19							J1	150-180		
A20							J2	180-216		

## Bin Code on Tag Cross Table

Luminous Intensity							Unit : mcd @ 20mA			
Bin Code On Tag	Blue		Green		Red					
	Code	Range	Code	Range	Code	Range				
B1	F2	60-72	K1	216-260	G2	86-104				
B2					H1	104-125				
B3					H2	125-150				
B4					J1	150-180				
B5					J2	180-216				
B6			K2	260-312			G2	86-104		
B7							H1	104-125		
B8							H2	125-150		
B9							J1	150-180		
B10							J2	180-216		
B11			L1	312-375			G2	86-104		
B12							H1	104-125		
B13							H2	125-150		
B14							J1	150-180		
B15							J2	180-216		
B16			L2	375-450			G2	86-104		
B17							H1	104-125		
B18							H2	125-150		
B19							J1	150-180		
B20							J2	180-216		



## Bin Code on Tag Cross Table

Luminous Intensity							Unit : mcd @ 20mA			
Bin Code On Tag	Blue		Green		Red					
	Code	Range	Code	Range	Code	Range				
C1	G1	72-86	K1	216-260	G2	86-104				
C2					H1	104-125				
C3					H2	125-150				
C4					J1	150-180				
C5					J2	180-216				
C6			K2	260-312			G2	86-104		
C7							H1	104-125		
C8							H2	125-150		
C9							J1	150-180		
C10							J2	180-216		
C11			L1	312-375			G2	86-104		
C12							H1	104-125		
C13							H2	125-150		
C14							J1	150-180		
C15							J2	180-216		
C16			L2	375-450			G2	86-104		
C17							H1	104-125		
C18							H2	125-150		
C19							J1	150-180		
C20							J2	180-216		

## Bin Code on Tag Cross Table

Luminous Intensity							Unit : mcd @ 20mA			
Bin Code On Tag	Blue		Green		Red					
	Code	Range	Code	Range	Code	Range				
D1	G2	86-104	K1	216-260	G2	86-104				
D2					H1	104-125				
D3					H2	125-150				
D4					J1	150-180				
D5					J2	180-216				
D6			K2	260-312			G2	86-104		
D7							H1	104-125		
D8							H2	125-150		
D9							J1	150-180		
D10							J2	180-216		
D11			L1	312-375			G2	86-104		
D12							H1	104-125		
D13							H2	125-150		
D14							J1	150-180		
D15							J2	180-216		
D16			L2	375-450			G2	86-104		
D17							H1	104-125		
D18							H2	125-150		
D19							J1	150-180		
D20							J2	180-216		

## Bin Code on Tag Cross Table

Luminous Intensity							Unit : mcd @ 20mA			
Bin Code On Tag	Blue		Green		Red					
	Code	Range	Code	Range	Code	Range				
E1	H1	104-125	K1	216-260	G2	86-104				
E2					H1	104-125				
E3					H2	125-150				
E4					J1	150-180				
E5					J2	180-216				
E6			K2	260-312			G2	86-104		
E7							H1	104-125		
E8							H2	125-150		
E9							J1	150-180		
E10							J2	180-216		
E11			L1	312-375			G2	86-104		
E12							H1	104-125		
E13							H2	125-150		
E14							J1	150-180		
E15							J2	180-216		
E16			L2	375-450			G2	86-104		
E17							H1	104-125		
E18							H2	125-150		
E19							J1	150-180		
E20							J2	180-216		

## Bin Code on Tag Cross Table

		Dominant Wavelength		Unit : nm @ 20mA		
Bin Code On Tag	Blue		Green		Red	
	Code	Range	Code	Range	Code	Range
F1	AC1	466-468.5	AN2	519-521.5	U	619-622
F2					V	622-625
F3					W	625-628
F4			AP1	521.5-524	U	619-622
F5					V	622-625
F6					W	625-628
F7			AP2	524-526.5	U	619-622
F8					V	622-625
F9					W	625-628
F10			AQ	526.5-529	U	619-622
F11					V	622-625
F12					W	625-628
G1	AC2	468.5-471	AN2	519-521.5	U	619-622
G2					V	622-625
G3					W	625-628
G4			AP1	521.5-524	U	619-622
G5					V	622-625
G6					W	625-628
G7			AP2	524-526.5	U	619-622
G8					V	622-625
G9					W	625-628
G10			AQ	526.5-529	U	619-622
G11					V	622-625
G12					W	625-628

## Bin Code on Tag Cross Table

		Dominant Wavelength		Unit : nm @ 20mA		
Bin Code On Tag	Blue		Green		Red	
	Code	Range	Code	Range	Code	Range
H1	AD1	471-473.5	AN2	519-521.5	U	619-622
H2					V	622-625
H3					W	625-628
H4			AP1	521.5-524	U	619-622
H5					V	622-625
H6					W	625-628
H7			AP2	524-526.5	U	619-622
H8					V	622-625
H9					W	625-628
H10			AQ	526.5-529	U	619-622
H11					V	622-625
H12					W	625-628

**Property of Lite-On Only**

**Typical Electrical / Optical Characteristics Curves**

(25°C Ambient Temperature Unless Otherwise Noted)

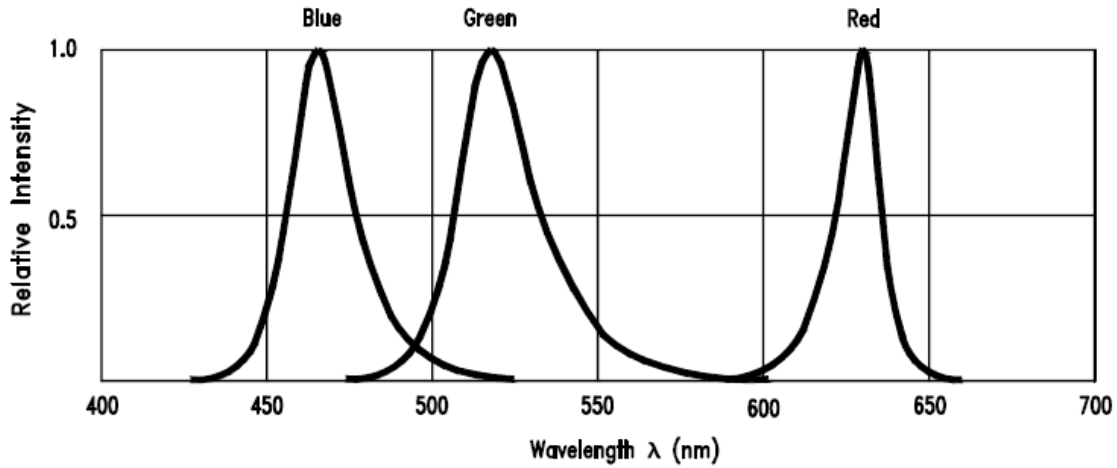

**Fig.1 Relative Intensity vs. Wavelength**

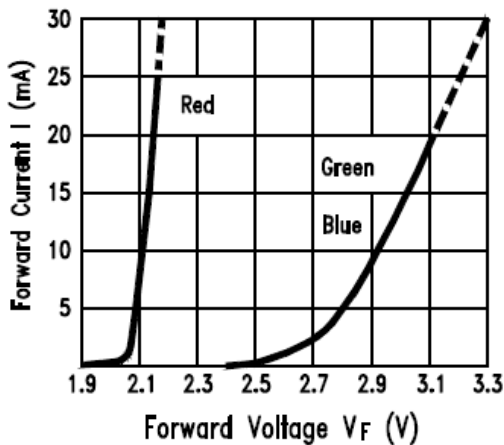

**Fig.2 Forward Current vs. Forward Voltage**

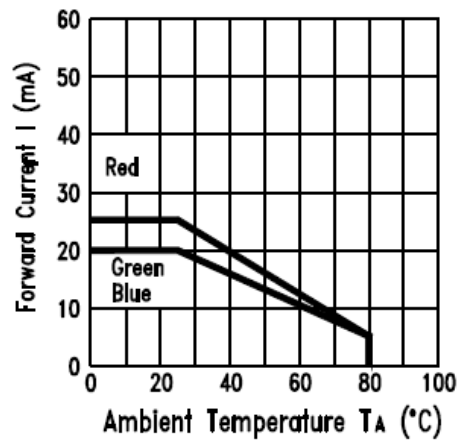

**Fig.3 Forward Current Derating Curve**

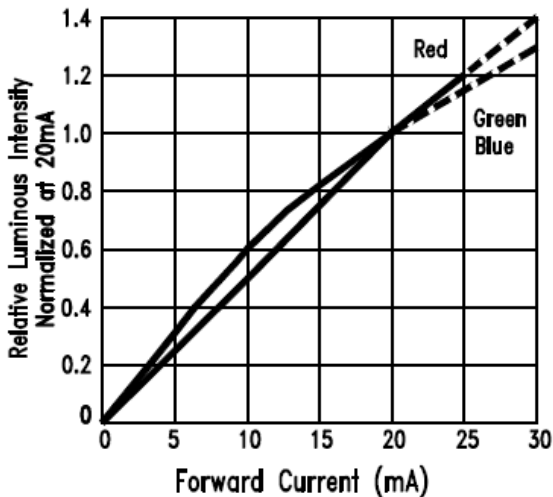

**Fig.4 Relative Luminous Intensity vs. Forward Current**

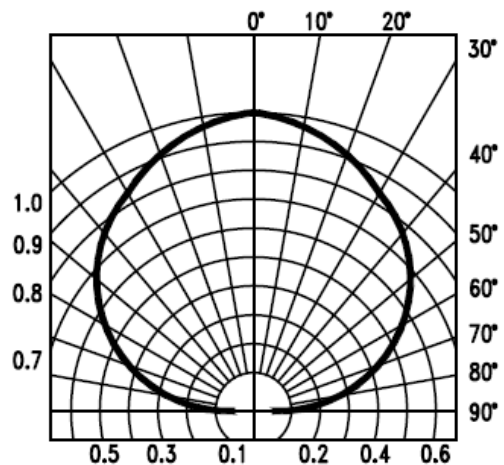
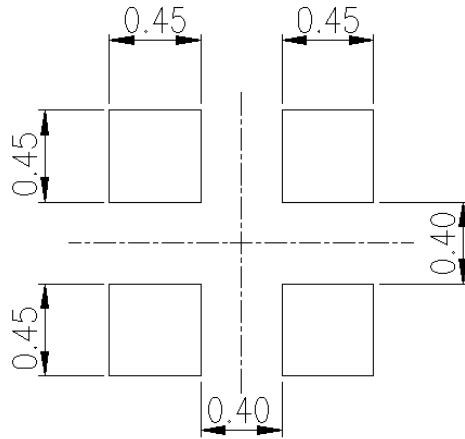

**Fig.5 Spatial Distribution**

## Cleaning

Do not use unspecified chemical liquid to clean LED they could harm the package.  
 If clean is necessary, immerse the LED in ethyl alcohol or in isopropyl alcohol at normal temperature for less one minute.

## Suggest Soldering Pad Dimensions



## Package Dimensions Of Tape And Reel

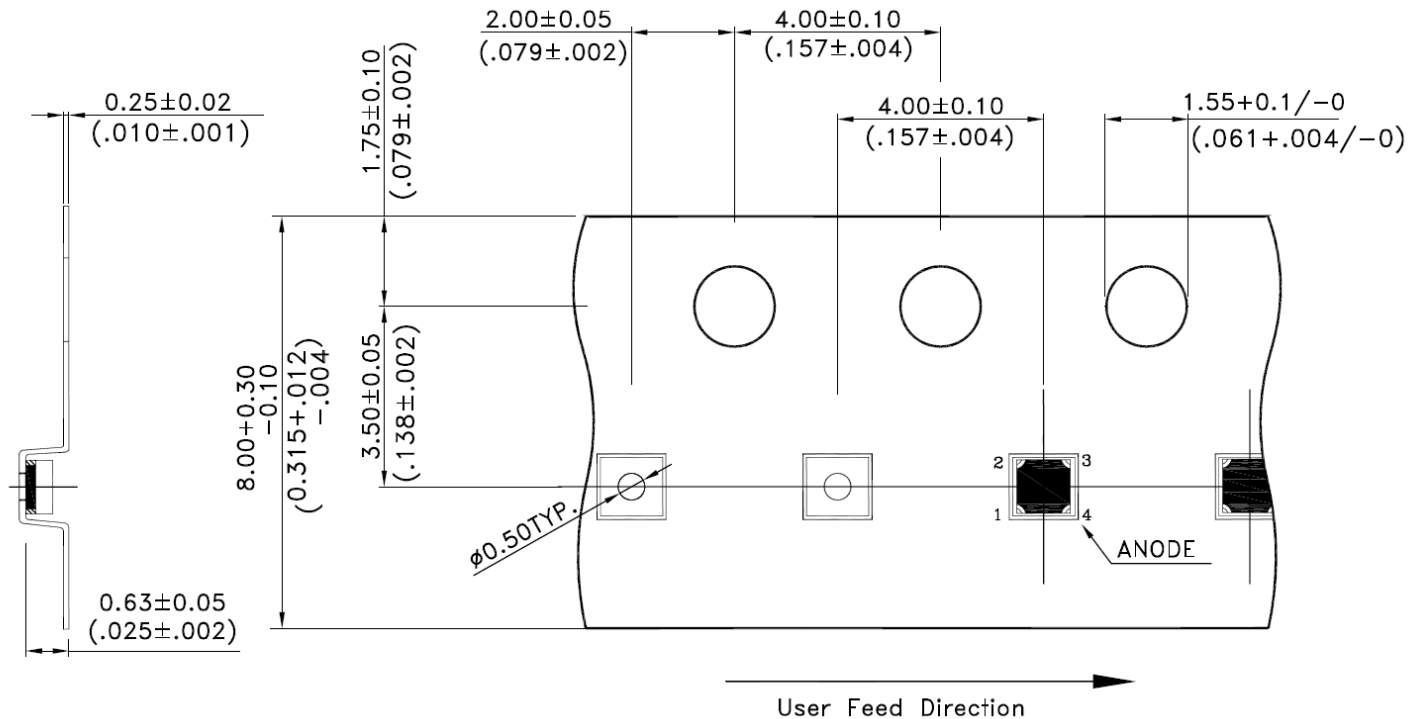

### Notes:

1. All dimensions are in millimeters (inches).

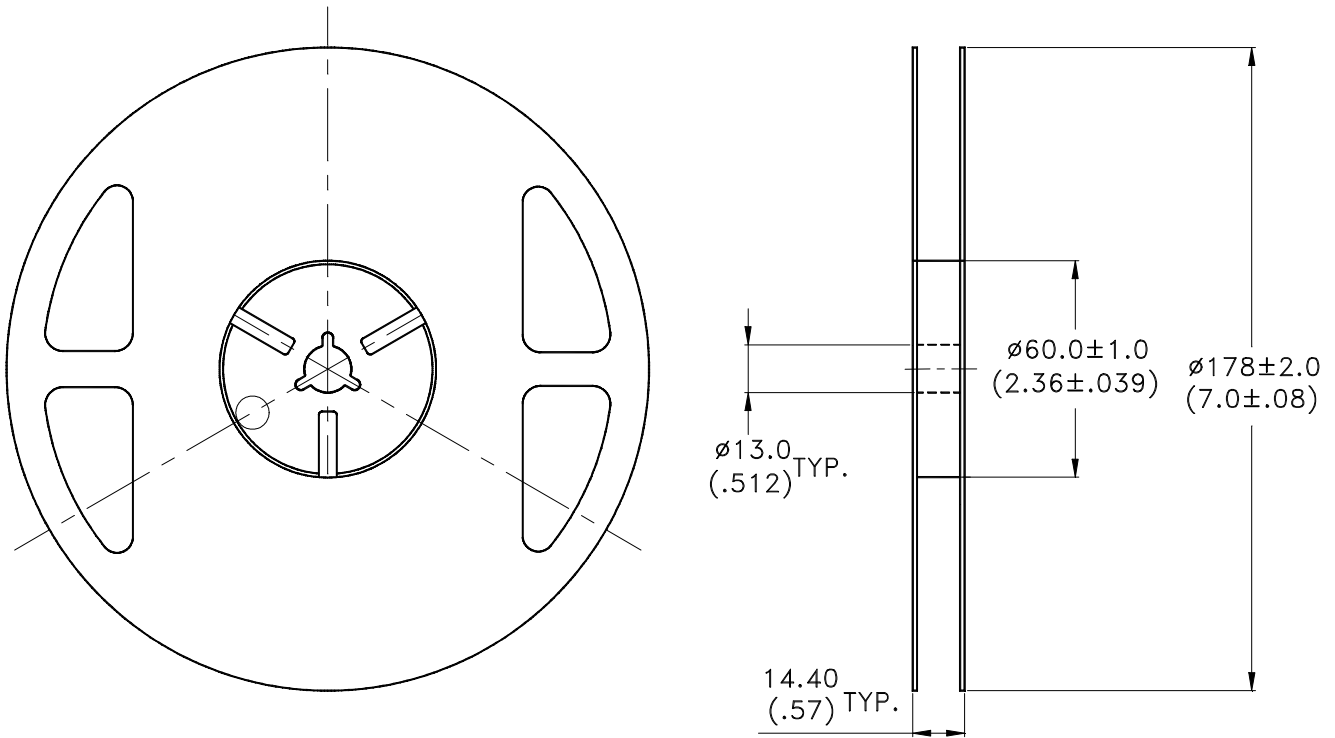

Notes:

1. Empty component pockets sealed with top cover tape.
2. 7 inch reel-2000 pieces per reel.
3. Minimum packing quantity is 500 pcs for remainders.
4. The maximum number of consecutive missing lamps is two.
5. In accordance with ANSI/EIA 481 specifications.



## CAUTIONS

### 1. Application

The LEDs described here are intended to be used for ordinary electronic equipment (such as office equipment, communication equipment and household applications). Consult Lite-on's Sales in advance for information on applications in which exceptional reliability is required, particularly when the failure or malfunction of the LEDs may directly jeopardize life or health (such as in aviation, transportation, traffic control equipment, medical and life support systems and safety devices).

### 2. Storage

The package is sealed:

The LEDs should be stored at 30°C or less and 90%RH or less. And the LEDs are limited to use within one year, while the LEDs is packed in moisture-proof package with the desiccants inside.

The package is opened:

The storage ambient for the LEDs should not exceed 30°C temperature or 60% relative humidity.

It is recommended that LEDs out of their original packaging are IR-reflowed within one week.

For extended storage out of their original packaging, it is recommended that the LEDs be stored in a sealed container with appropriate desiccant, or in a desiccators with nitrogen ambient.

LEDs stored out of their original packaging for more than one week should be baked at about 60 deg C for at least 20 hours before solder assembly.

### 3. Cleaning

Use alcohol-based cleaning solvents such as isopropyl alcohol to clean the LED if necessary.

### 4. Soldering

Recommended soldering conditions:

Reflow soldering		Soldering iron	
Pre-heat	150~200°C	Temperature	300°C Max.
Pre-heat time	120 sec. Max.	Soldering time	3 sec. Max.
Peak temperature	260°C Max.		(one time only)
Soldering time	10 sec. Max.(Max. two times)		

### Soldering notes:

Because different board designs use different number and types of devices, solder pastes, reflow ovens, and circuit boards, no single temperature profile works for all possible combinations.

However, you can successfully mount your packages to the PCB by following the proper guidelines and PCB-specific characterization.

LITE-ON Runs both component-level verification using in-house **KYRAMX98** reflow chambers and board-level assembly.

The results of this testing are verified through post-reflow reliability testing.

Profiles used at LITE-ON are based on JEDEC standards to ensure that all packages can be successfully and reliably surface mounted.

Figure on page3 shows a sample temperature profile compliant to JEDEC standards.

You can use this example as a generic target to set up your reflow process.

You should adhere to the JEDEC profile limits as well as specifications and recommendations from the solder paste manufacturer to avoid damaging the device and create a reliable solder joint.

## 5. Drive Method

An LED is a current-operated device. In order to ensure intensity uniformity on multiple LEDs connected in parallel in an application, it is recommended that a current limiting resistor be incorporated in the drive circuit, in series with each LED as shown in Circuit A below.

**Circuit model A**

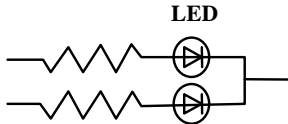

(A) Recommended circuit.

**Circuit model B**

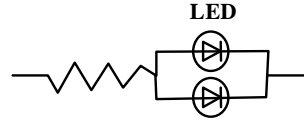

(B) The brightness of each LED might appear different due to the differences in the I-V characteristics of those LEDs.

## 6. ESD (Electrostatic Discharge)

Static Electricity or power surge will damage the LED.

Suggestions to prevent ESD damage:

- Use of a conductive wrist band or anti-electrostatic glove when handling these LEDs.
- All devices, equipment, and machinery must be properly grounded.
- Work tables, storage racks, etc. should be properly grounded.
- Use ion blower to neutralize the static charge which might have built up on surface of the LED's plastic lens as a result of friction between LEDs during storage and handling.

ESD-damaged LEDs will exhibit abnormal characteristics such as high reverse leakage current, low forward voltage, or “ no lightup ” at low currents.

To verify for ESD damage, check for “ lightup ” and Vf of the suspect LEDs at low currents.

The Vf of “ good ” LEDs should be  $>2.0V@0.1mA$  for InGaN product and  $>1.4V@0.1mA$  for AlInGaP product.

## 7. Reliability Test

Classification	Test Item	Test Condition	Reference Standard
Endurance Test	Operation Life	Ta= Under Room Temperature As Per Data Sheet Maximum Rating *Test Time= 1000HRS (-24HRS,+72HRS)	MIL-STD-750D:1026 MIL-STD-883D:1005 JIS C 7021:B-1
	High Temperature High Humidity Storage	IR-Reflow In-Board, 2 Times Ta= 65±5°C, RH= 90~95% *Test Time= 240HRS±2HRS	MIL-STD-202F:103B JIS C 7021:B-11
	High Temperature Storage	Ta= 105±5°C *Test Time= 1000HRS (-24HRS,+72HRS)	MIL-STD-883D:1008 JIS C 7021:B-10
	Low Temperature Storage	Ta= -55±5°C *Test Time=1000HRS (-24HRS,+72HRS)	JIS C 7021:B-12
Environmental Test	Temperature Cycling	105°C ~ 25°C ~ -55°C ~ 25°C 30mins 5mins 30mins 5mins 10 Cycles	MIL-STD-202F:107D MIL-STD-750D:1051 MIL-STD-883D:1010 JIS C 7021:A-4
	Thermal Shock	IR-Reflow In-Board, 2 Times 85 ± 5°C ~ -40°C ± 5°C 10mins 10mins 10 Cycles	MIL-STD-202F:107D MIL-STD-750D:1051 MIL-STD-883D:1011
	Solder Resistance	T.sol= 260 ± 5°C Dwell Time= 10 ± 1secs	MIL-STD-202F:210A MIL-STD-750D:2031 JIS C 7021:A-1
	IR-Reflow Pb Free Process	Ramp-up rate(217°C to Peak) +3°C/ second max Temp. maintain at 175(±25)°C 180 seconds max Temp. maintain above 217°C 60-150 seconds Peak temperature range 260°C+0/-5°C Time within 5°C of actual Peak Temperature (tp) 10~30 seconds Ramp-down rate +6°C/second max	MIL-STD-750D:2031.2 J-STD-020D
Solderability	T.sol= 235 ± 5°C Immersion time 2±0.5 sec Immersion rate 25±2.5 mm/sec Coverage ≥95% of the dipped surface	MIL-STD-202F:208D MIL-STD-750D:2026 MIL-STD-883D:2003 IEC 68 Part 2-20 JIS C 7021:A-2	

## 8. Others

The appearance and specifications of the product may be modified for improvement without prior notice.

**9. Suggested Checking List**

## Training and Certification

1. Everyone working in a static-safe area is ESD-certified?
2. Training records kept and re-certification dates monitored?

## Static-Safe Workstation &amp; Work Areas

1. Static-safe workstation or work-areas have ESD signs?
2. All surfaces and objects at all static-safe workstation and within 1 ft measure less than 100V?
3. All ionizer activated, positioned towards the units?
4. Each work surface mats grounding is good?

## Personnel Grounding

1. Every person (including visitors) handling ESD sensitive (ESDS) items wears wrist strap, heel strap or conductive shoes with conductive flooring?
2. If conductive footwear used, conductive flooring also present where operator stand or walk?
3. Garments, hairs or anything closer than 1 ft to ESD items measure less than 100V\*?
4. Every wrist strap or heel strap/conductive shoes checked daily and result recorded for all DLs?
5. All wrist strap or heel strap checkers calibration up to date?

Note: \*50V for Blue LED.

## Device Handling

1. Every ESDS items identified by EIA-471 labels on item or packaging?
2. All ESDS items completely inside properly closed static-shielding containers when not at static-safe workstation?
3. No static charge generators (e.g. plastics) inside shielding containers with ESDS items?
4. All flexible conductive and dissipative package materials inspected before reuse or recycles?

## Others

1. Audit result reported to entity ESD control coordinator?
2. Corrective action from previous audits completed?
3. Are audit records complete and on file?