

PRODUCT SUMMARY

SKY74091: Receiver for CDMA, AMPS, PCS, and GPS Mobile Handset Applications

Applications

- Tri-band, quad-mode handsets
- PCS and GPS phones
- CDMA and GPS phones

Features

- Two-step gain control, PCS LNA
- Three-step gain control, cellular LNA
- GPS LNA
- External resistor to adjust LNA bias current
- Independent AMPS, CDMA, PCS, and GPS mixers
- Single LO input for CDMA, PCS, and GPS mixer
- Buffered LO signal for transmit upconverter
- Single external UHF VCO for PLL circuitry
- 90 dB dynamic range VGA
- Integrated VHF oscillator and tank circuit
- VCO_ON control for current optimization
- Battery cell operation ($2.7\text{ V} < VCC < 3.3\text{ V}$)
- RFLGA™ package (48-pin, 7 x 7 mm) with down-set paddle

Description

The SKY74091 is a highly integrated, super-heterodyne receiver. This single Intermediate Frequency (IF), multi-mode, tri-band receiver is intended for use in Code Division Multiple Access (CDMA) phones in Personal Communications System (PCS), cellular CDMA, Advanced Mobile Phone System (AMPS), and Global Positioning System (GPS) modes.

Except for the Surface Acoustic Wave (SAW) filters and matching components, the device incorporates all the components required to implement the receiver chain, from the Low-Noise Amplifier (LNA) to the In-Phase and Quadrature (I/Q) demodulator stages. Three LNAs are in the front-end receiver: a three-step gain stage cellular LNA (high, mid, and bypass), a two-step gain stage PCS LNA (high, bypass), and a high gain stage GPS LNA.

After RF LNA signal amplification and filtering from the antenna, the received signal is mixed down from RF to the IF. There are separate mixers for AMPS, CDMA-cellular, CDMA-PCS, and GPS modes. To use a single IF frequency plan, the CDMA and PCS mixer outputs have been combined. Therefore, both CDMA and PCS bands use the same IF SAW filter. The AMPS differential output can be combined externally to mate to a single-ended SAW filter.

The GPS mixer is an image-reject mixer, which eliminates the need for an external RF SAW filter between the LNA and mixer. The GPS image-reject mixer has a differential output for an external L-C bandpass filter. After IF filtering, the IF signal is amplified by a Variable Gain Amplifier (VGA) and fed to an I/Q demodulator, resulting in baseband I/Q signals at the output.

The SKY74091 is also designed with a single Local Oscillator (LO) input port for the AMPS/CDMA/PCS/GPS mixer. These mixers operate at different RF frequency inputs, but have the same IF frequency output. This usually refers to a single IF plan at 183.6 MHz.

The LO_IN signal (pin 39) provides an LO port for the CDMA/PCS/GPS mixers. In the cellular band, an internal divider divides the frequency by two, which provides the LO input to the cellular mixer. In the GPS band, the UHF LO frequency is 2/3 that of the UHF VCO frequency. This allows only a single external VCO. The UHF VCO is also buffered and amplified internally, which provides the LO to drive the transmitter upconverter LO port.

The VGA has a minimum dynamic range of 90 dB with a control voltage range of 0.5 to 2.5 V, which is common to all modes. A VHF oscillator operates with external tank circuits to provide LO frequencies for the I/Q demodulator in the cellular, PCS, and GPS modes.

The noise figure, gain, and third order Input Intercept Point (IIP3) of each stage in the receiver are optimized to meet the system requirements for AMPS and CDMA modes according to TIA/EIA-98-C. The design employs SiGe BiCMOS technology for low cost, high performance, and a high level of integration.

A block diagram of the SKY74091 is shown in Figure 1.

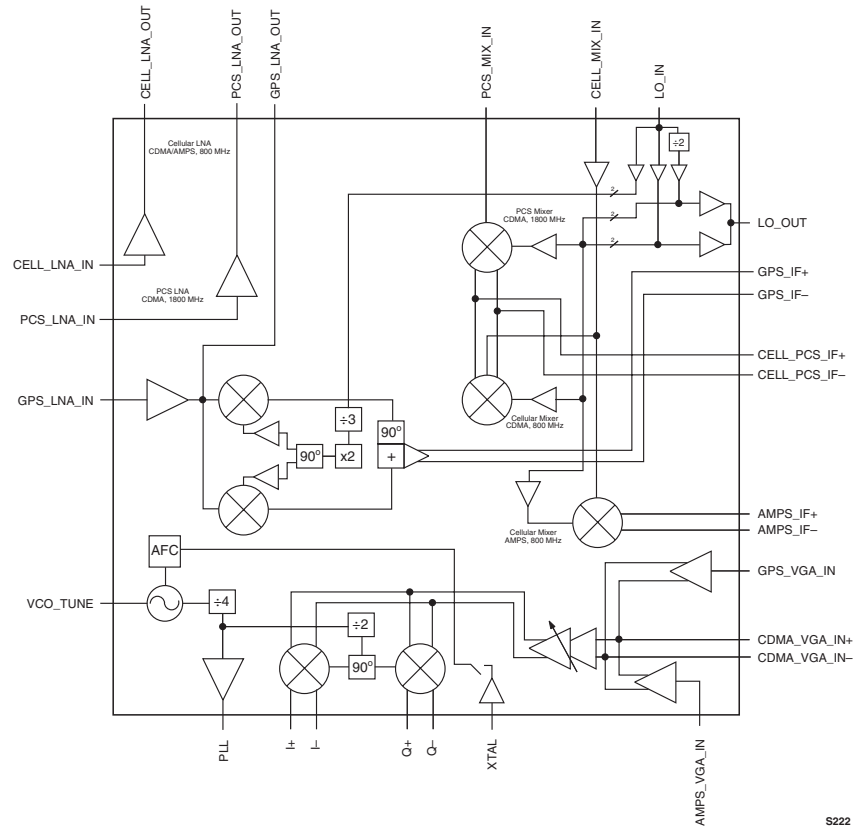

Figure 1. SKY74091 Receiver Block Diagram

Ordering Information

Model Name	Manufacturing Part Number	Product Revision
SKY74091 CDMA, AMPS, PCS, and GPS Receiver	SKY74091-11	

Copyright © 2003, 2004, Skyworks Solutions, Inc. All Rights Reserved.

Information in this document is provided in connection with Skyworks Solutions, Inc. ("Skyworks") products. These materials are provided by Skyworks as a service to its customers and may be used for informational purposes only by the customer. Skyworks assumes no responsibility for errors or omissions in these materials. Skyworks may make changes to its documentation, products, specifications and product descriptions at any time, without notice. Skyworks makes no commitment to update the information and shall have no responsibility whatsoever for conflicts, incompatibilities, or other difficulties arising from future changes to its documentation, products, specifications and product descriptions.

No license, express or implied, by estoppel or otherwise, to any intellectual property rights is granted by or under this document. Except as may be provided in Skyworks' Terms and Conditions of Sale for such products, Skyworks assumes no liability whatsoever in association with its documentation, products, specifications and product descriptions.

THESE MATERIALS ARE PROVIDED "AS IS" WITHOUT WARRANTY OF ANY KIND, EITHER EXPRESS OR IMPLIED OR OTHERWISE, RELATING TO SALE AND/OR USE OF SKYWORKS PRODUCTS INCLUDING WARRANTIES RELATING TO FITNESS FOR A PARTICULAR PURPOSE, MERCHANTABILITY, PERFORMANCE, QUALITY OR NON-INFRINGEMENT OF ANY PATENT, COPYRIGHT OR OTHER INTELLECTUAL PROPERTY RIGHT. SKYWORKS FURTHER DOES NOT WARRANT THE ACCURACY OR COMPLETENESS OF THE INFORMATION, TEXT, GRAPHICS OR OTHER ITEMS CONTAINED WITHIN THESE MATERIALS. SKYWORKS SHALL NOT BE LIABLE FOR ANY DAMAGES, INCLUDING SPECIAL, INDIRECT, INCIDENTAL, OR CONSEQUENTIAL DAMAGES, INCLUDING WITHOUT LIMITATION, LOST REVENUES OR LOST PROFITS THAT MAY RESULT FROM THE USE OF THESE MATERIALS WHETHER OR NOT THE RECIPIENT OF MATERIALS HAS BEEN ADVISED OF THE POSSIBILITY OF SUCH DAMAGE.

Skyworks products are not intended for use in medical, lifesaving or life-sustaining applications. Skyworks' customers using or selling Skyworks products for use in such applications do so at their own risk and agree to fully indemnify Skyworks for any damages resulting from such improper use or sale.

The following are trademarks of Skyworks Solutions, Inc.: Skyworks™, the Skyworks logo, and Breakthrough Simplicity™. Product names or services listed in this publication are for identification purposes only, and may be trademarks of Skyworks or other third parties. Third-party brands and names are the property of their respective owners. Additional information, posted at www.skyworksinc.com, is incorporated by reference.