

**ESD protected N-Channel Enhancement Mode MOSFET**

# MTNK5S3

$BV_{DSS}$	30V
$I_D$	100mA
$R_{DS(on)(MAX)}$	8Ω

**Description**

- Low voltage drive(2.5V drive) makes this device ideal for portable equipment.
- High speed switching
- ESD protected device
- Pb-free lead plating & halogen-free package

**Symbol**

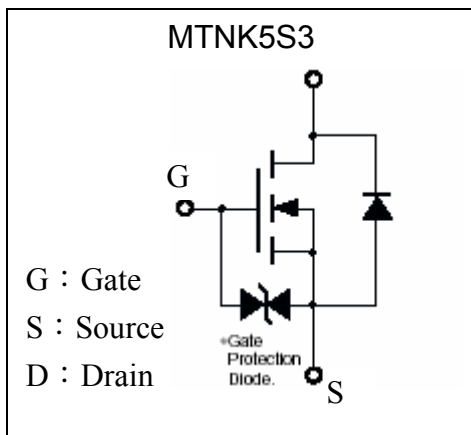

**Outline**

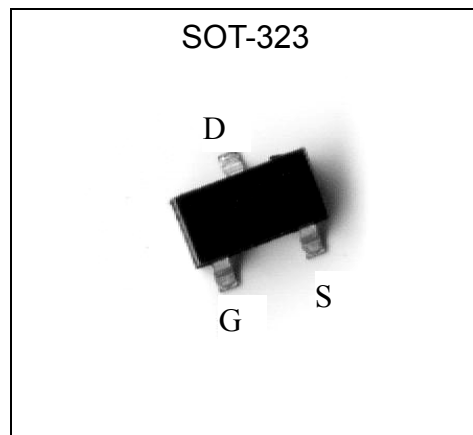

**Ordering Information**

Device	Package	Shipping
MTNK5S3-0-T1-G	SOT-323 (Pb-free lead plating & halogen-free package)	3000 pcs / Tape & Reel



**Absolute Maximum Ratings (Ta=25°C)**

Parameter	Symbol	Limits	Unit
Drain-Source Voltage	BV <sub>DSS</sub>	30	V
Gate-Source Voltage	V <sub>GS</sub>	±20	V
Drain Current	Continuous	±100	mA
	Pulsed	±200 *1	mA
Reverse Drain Current	Continuous	±100	mA
	Pulsed	±200 *1	mA
Total Power Dissipation	P <sub>D</sub>	200 *2	mW
ESD susceptibility		750 *3	V
Operating Junction and Storage Temperature Range	T <sub>j</sub> ; T <sub>stg</sub>	-55~+150	°C
Thermal Resistance, Junction-to-Ambient	R <sub>th,ja</sub>	556	°C/W

Note : \*1. Pulse Width ≤ 10μs, Duty cycle ≤1%  
 \*2. With each pin mounted on the recommended lands.  
 \*3. Human body model, 1.5kΩ in series with 100pF

**Electrical Characteristics (Ta=25°C)**

Symbol	Min.	Typ.	Max.	Unit	Test Conditions
<b>Static</b>					
BV <sub>DSS</sub>	30	-	-	V	V <sub>GS</sub> =0, I <sub>D</sub> =100μA
V <sub>GS(th)</sub>	0.8	1.3	1.5	V	V <sub>DS</sub> =3V, I <sub>D</sub> =100μA
I <sub>GSS</sub>	-	-	±1	μA	V <sub>GS</sub> =±20V, V <sub>DS</sub> =0
I <sub>DSS</sub>	-	-	100	nA	V <sub>DS</sub> =30V, V <sub>GS</sub> =0
R <sub>Ds(ON)</sub>	-	3.4	8	Ω	V <sub>GS</sub> =4V, I <sub>D</sub> =10mA
	-	6.9	13		V <sub>GS</sub> =2.5V, I <sub>D</sub> =1mA
G <sub>FS</sub>	20	50	-	mS	V <sub>DS</sub> =3V, I <sub>D</sub> =10mA
<b>Dynamic</b>					
C <sub>iss</sub>	-	12.5	-	pF	V <sub>DS</sub> =5V, V <sub>GS</sub> =0, f=1MHz
C <sub>oss</sub>	-	7.3	-		
C <sub>rss</sub>	-	3.5	-		
t <sub>d(on)</sub>	-	15	-	ns	V <sub>DD</sub> ≐ 5V, I <sub>D</sub> =10mA, V <sub>GS</sub> =5V, R <sub>L</sub> =500Ω, R <sub>G</sub> =10Ω
t <sub>r</sub>	-	35	-		
t <sub>d(off)</sub>	-	75	-		
t <sub>f</sub>	-	75	-		
<b>Source-Drain Diode</b>					
*V <sub>SD</sub>	-	0.88	1.2	V	V <sub>GS</sub> =0V, I <sub>S</sub> =100mA

\*Pulse Test : Pulse Width ≤300μs, Duty Cycle ≤2%



### Typical Characteristics

Typical Output Characteristics

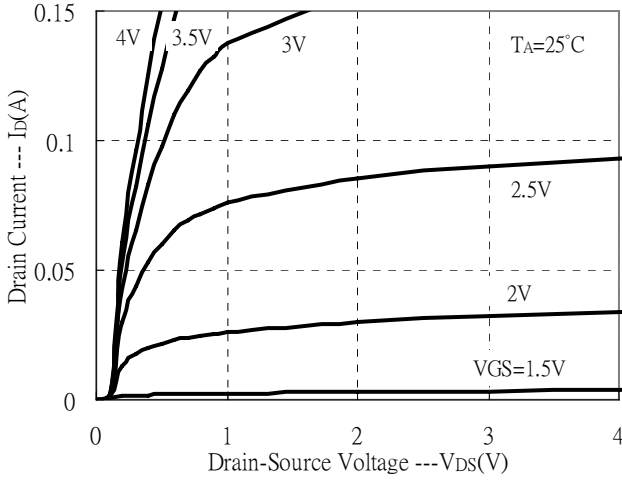

Gate Threshold Voltage vs Channel Temperature

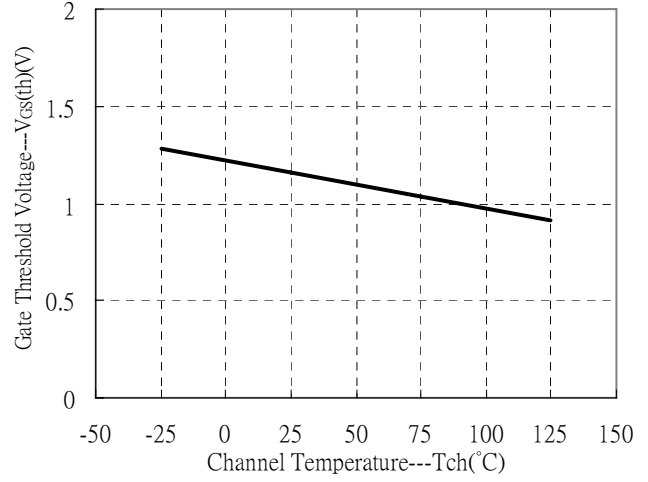

Typical Transfer Characteristics

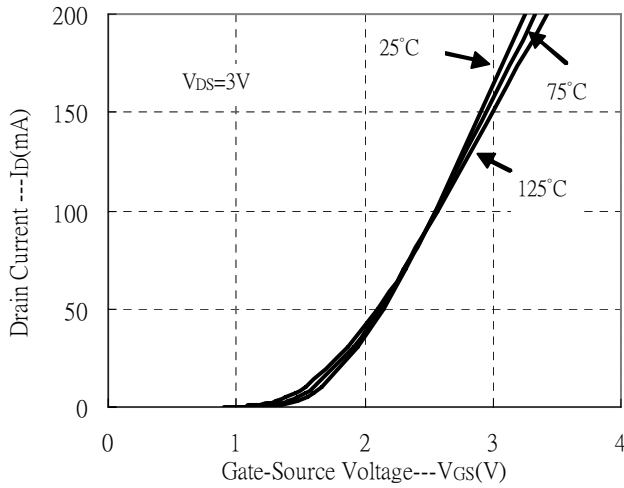

Static Drain-Source On-state Resistance with Temperature

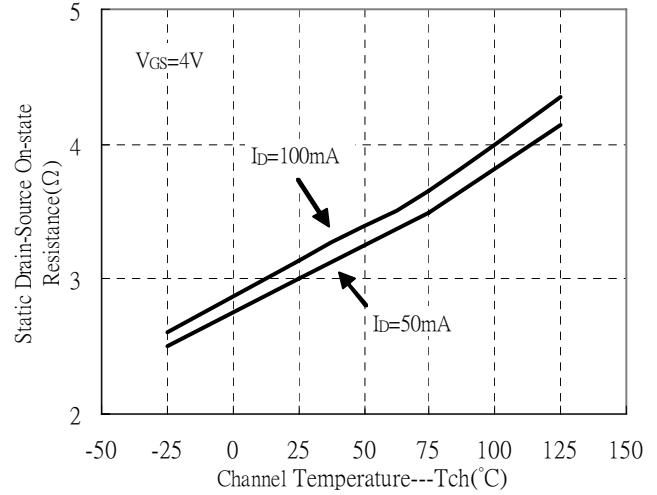

Static Drain-Source On-State resistance vs Drain Current

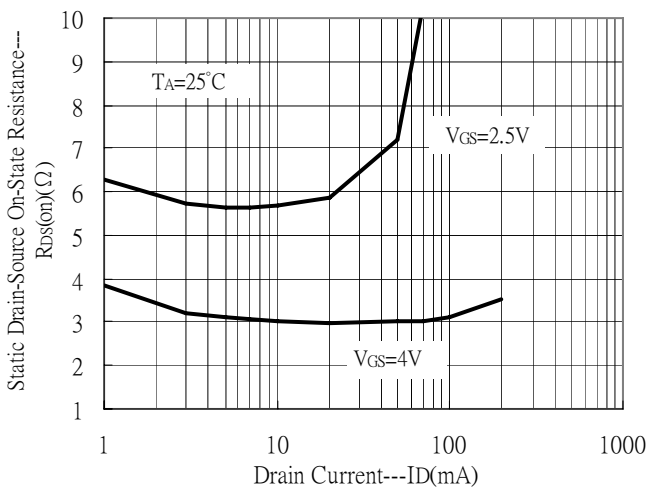

Static Drain-Source On-State resistance vs Drain Current

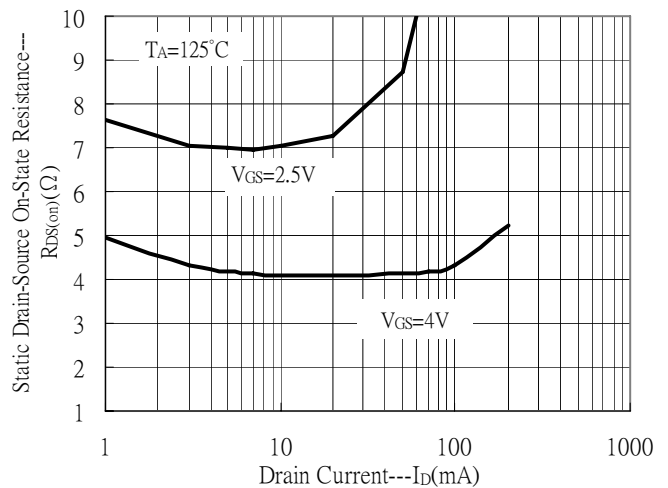

**Typical Characteristics(Cont.)**

Static Drain-Source On-State Resistance vs Drain Current

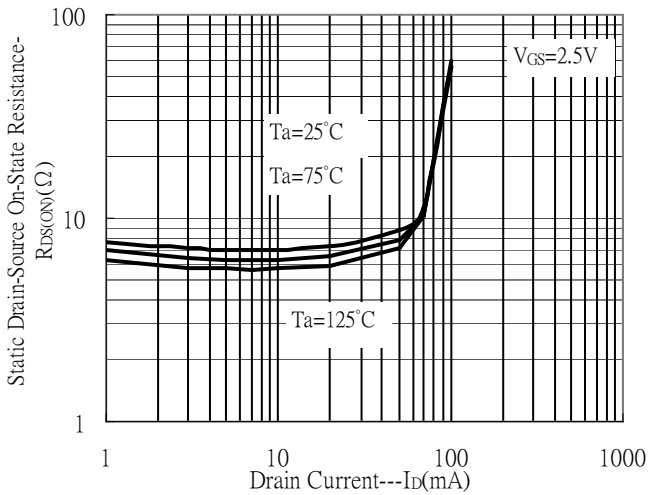

Static Drain-Source On-State Resistance vs Drain Current

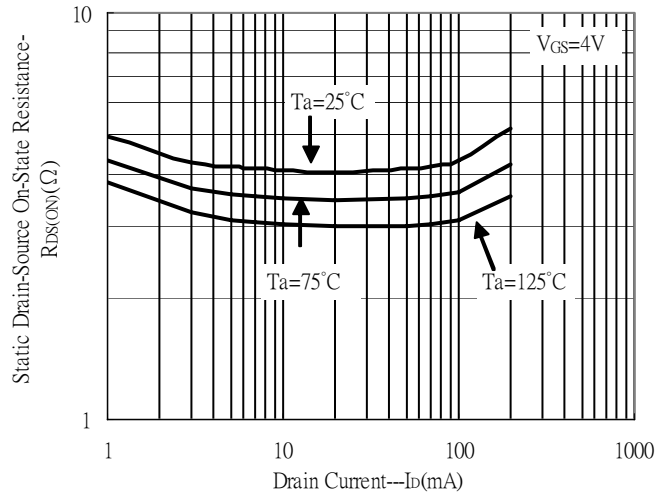

Static Drain-Source On-State Resistance vs Gate-Source Voltage

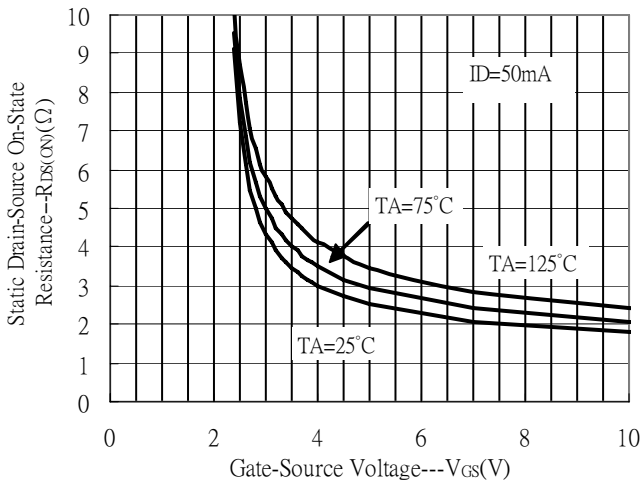

Static Drain-Source On-State Resistance vs Gate-Source Voltage

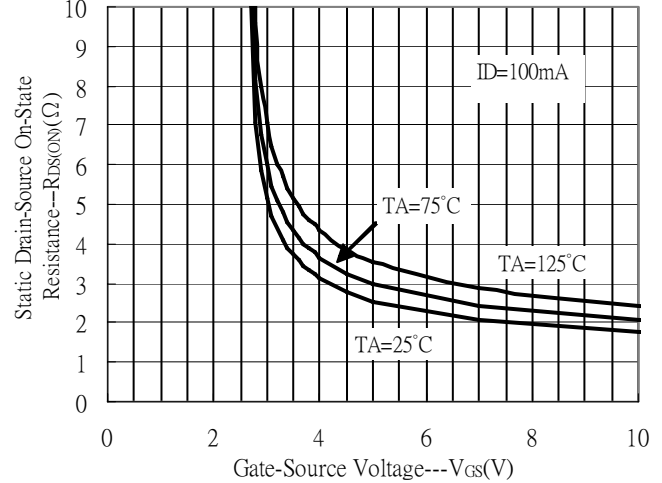

Reverse Drain Current vs Source-Drain Voltage(I)

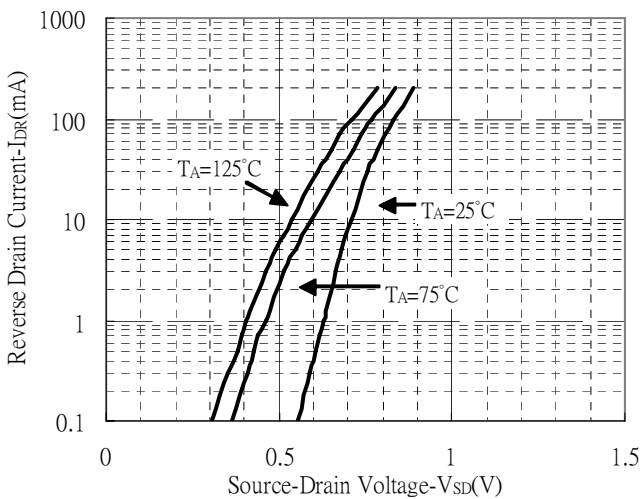

Reverse Drain Current vs Source-Drain Voltage(II)

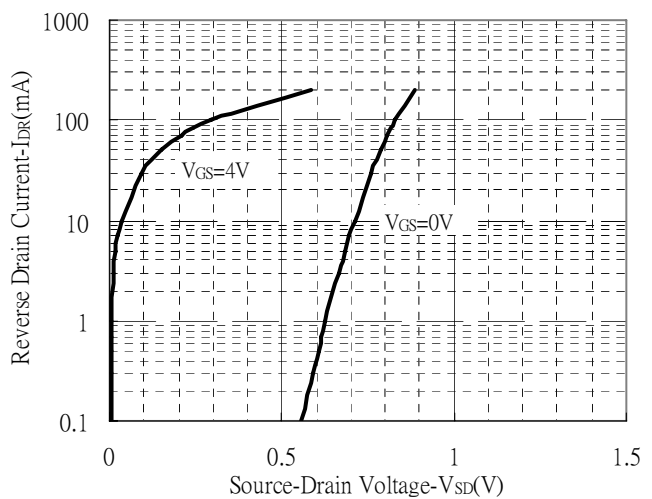



### Typical Characteristics(Cont.)

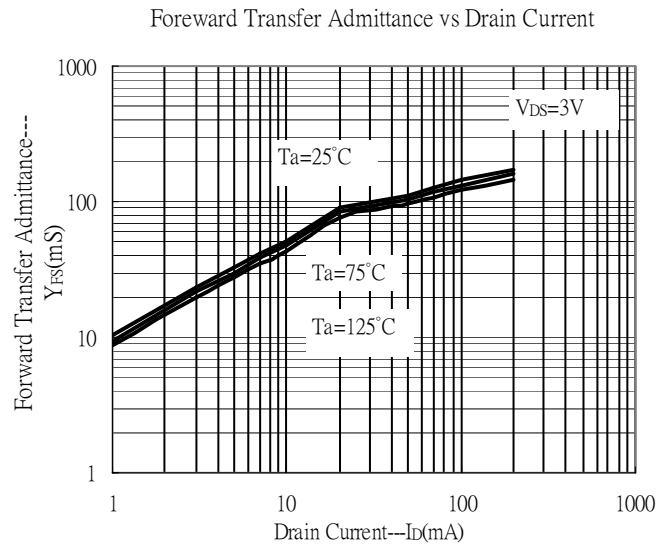
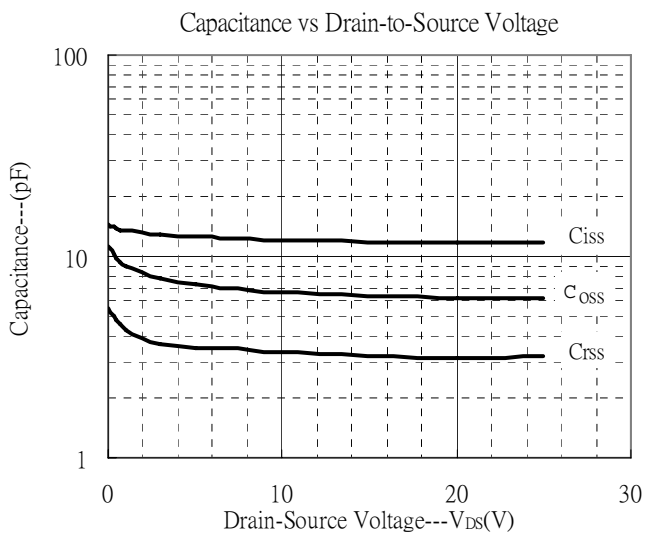

**Reel Dimension**

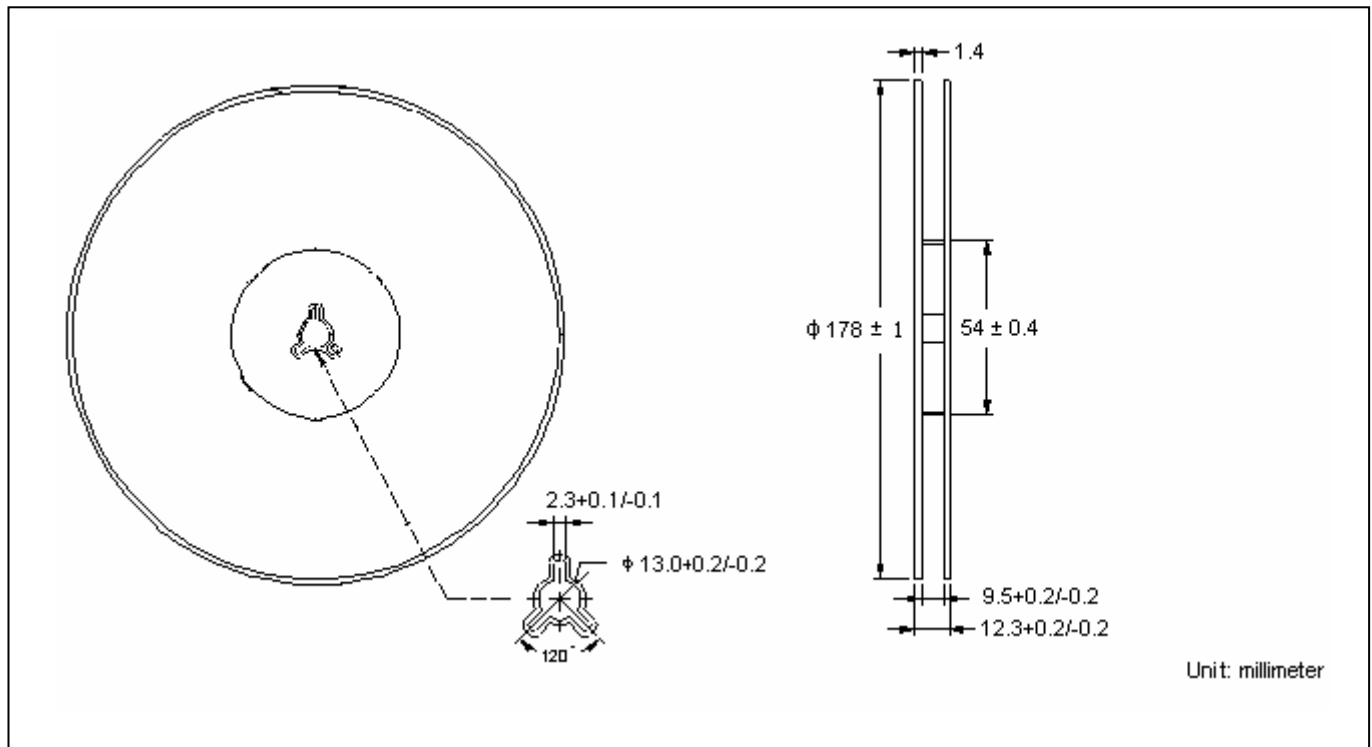

**Carrier Tape Dimension**

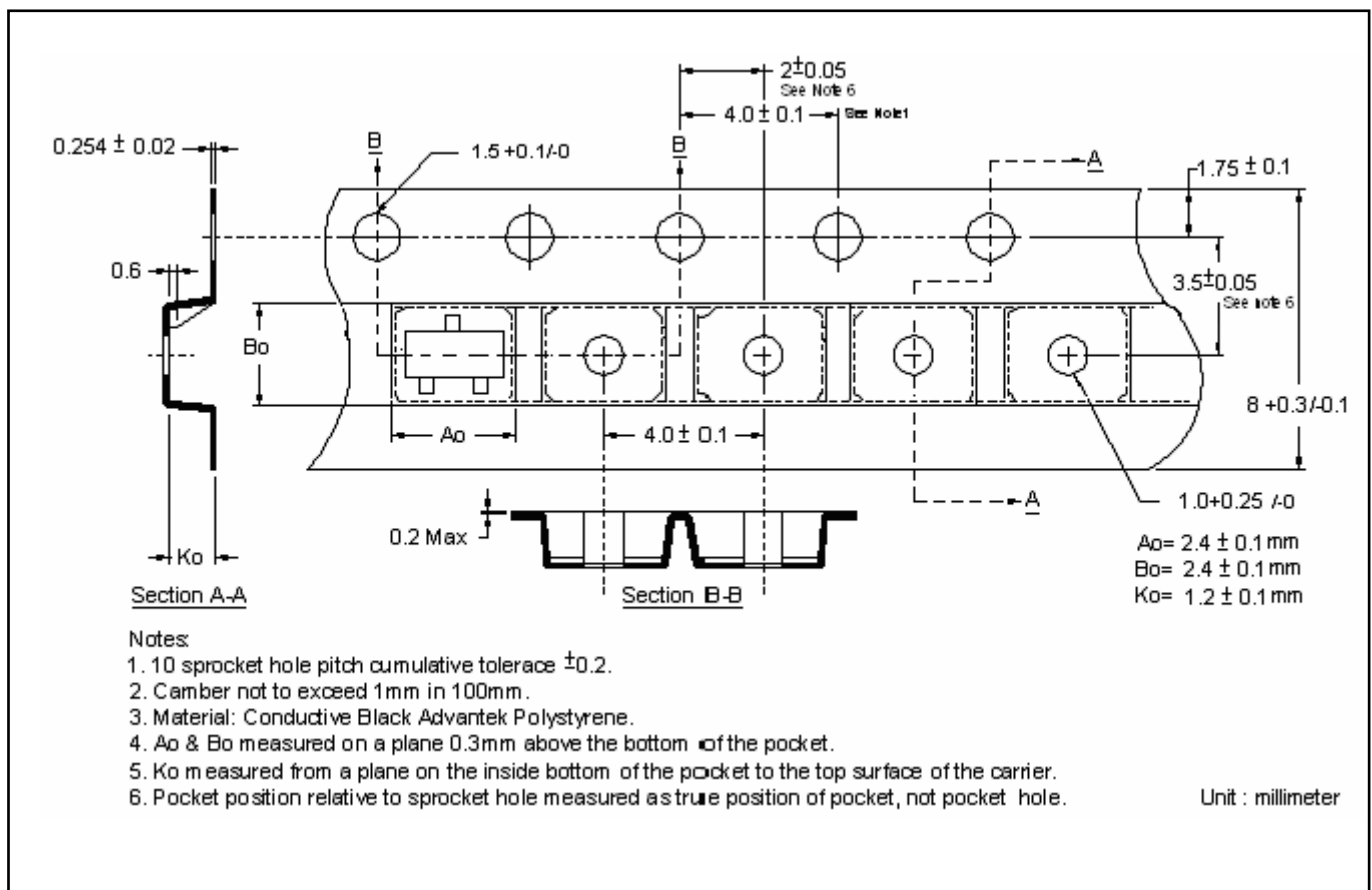

**Recommended wave soldering condition**

Product	Peak Temperature	Soldering Time
Pb-free devices	260 +0/-5 °C	5 +1/-1 seconds

**Recommended temperature profile for IR reflow**

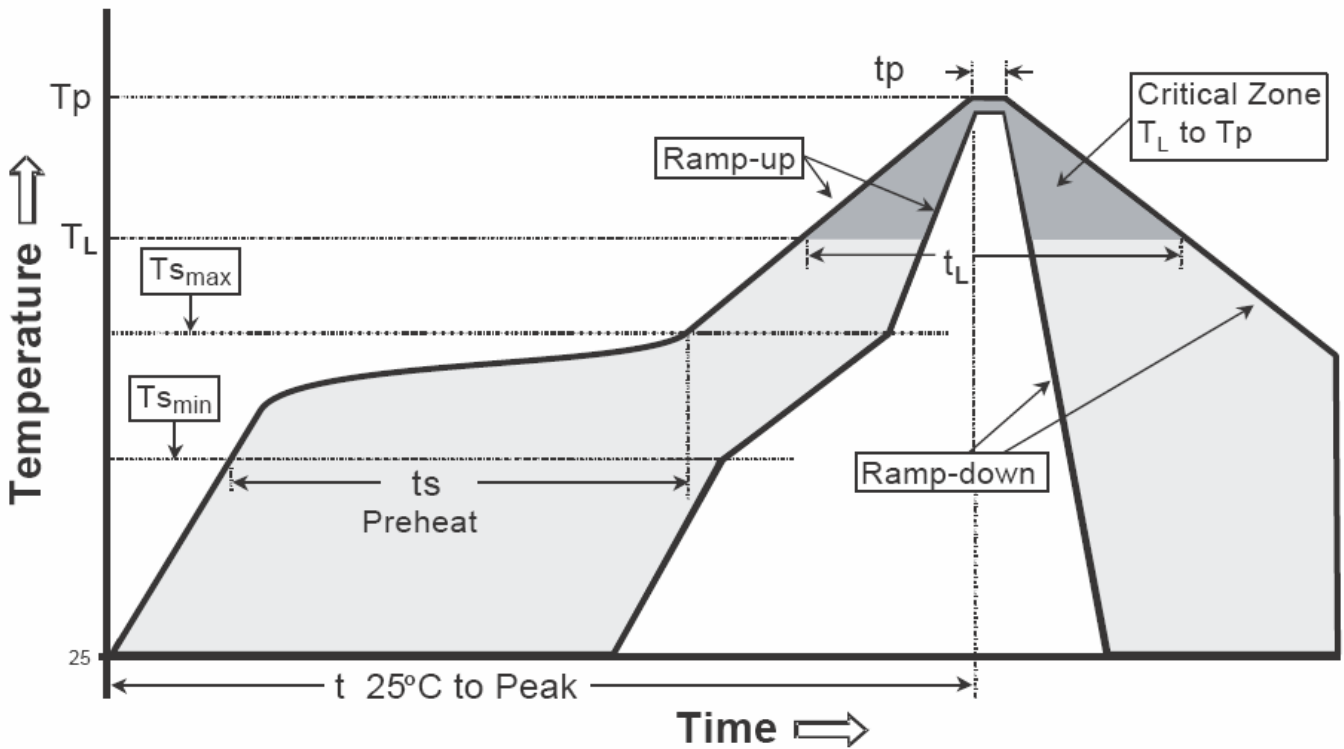

Profile feature	Sn-Pb eutectic Assembly	Pb-free Assembly
Average ramp-up rate (Tsmax to Tp)	3°C/second max.	3°C/second max.
Preheat		
-Temperature Min(Ts min)	100°C	150°C
-Temperature Max(Ts max)	150°C	200°C
-Time(ts min to ts max)	60-120 seconds	60-180 seconds
Time maintained above:		
-Temperature (Tl)	183°C	217°C
- Time (tL)	60-150 seconds	60-150 seconds
Peak Temperature(TP)	240 +0/-5 °C	260 +0/-5 °C
Time within 5°C of actual peak temperature(tp)	10-30 seconds	20-40 seconds
Ramp down rate	6°C/second max.	6°C/second max.
Time 25 °C to peak temperature	6 minutes max.	8 minutes max.

Note : All temperatures refer to topside of the package, measured on the package body surface.

**SOT-323 Dimension**

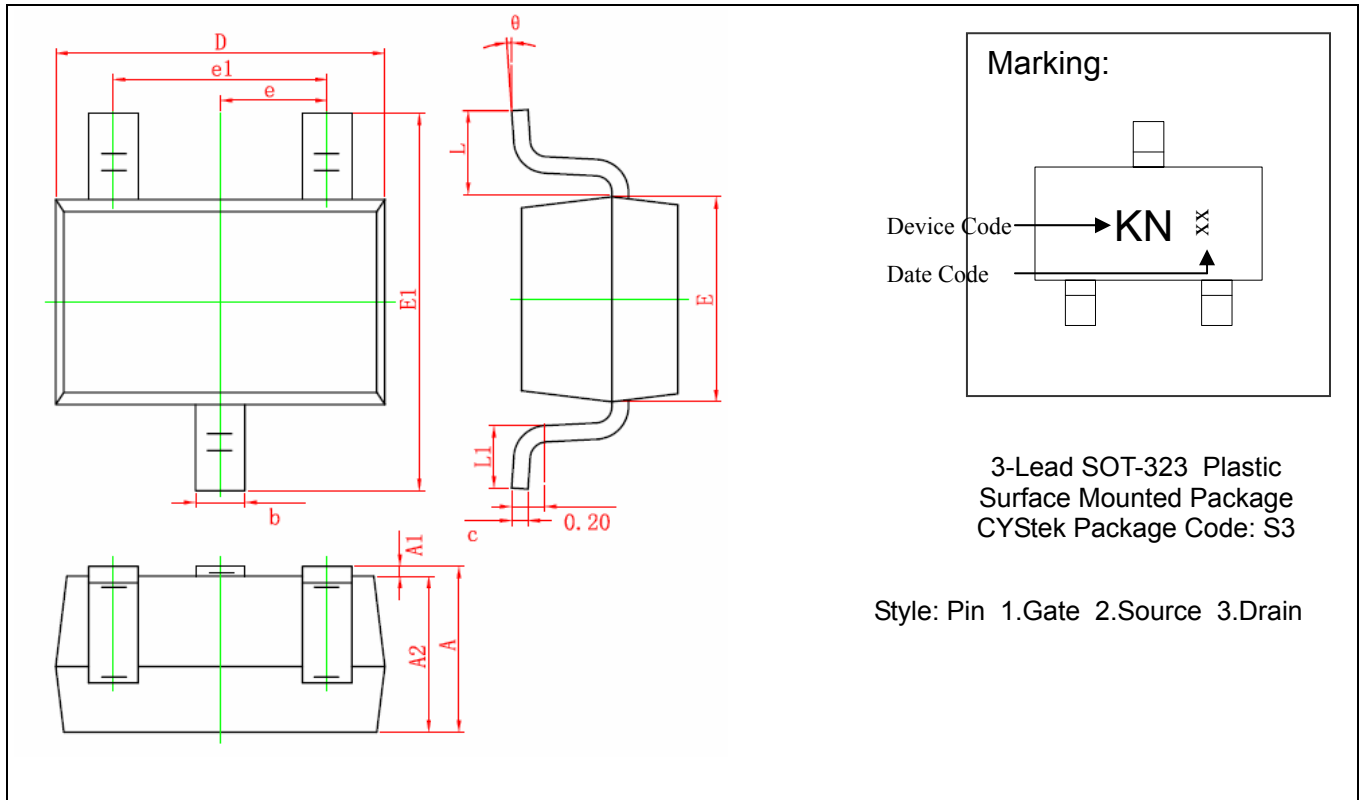

DIM	Millimeters		Inches		DIM	Millimeters		Inches	
	Min.	Max.	Min.	Max.		Min.	Max.	Min.	Max.
A	0.900	1.100	0.035	0.043	E1	2.150	2.450	0.085	0.096
A1	0.000	0.100	0.000	0.004	e	0.650	TYP	0.026	TYP
A2	0.900	1.000	0.035	0.039	e1	1.200	1.400	0.047	0.055
b	0.200	0.400	0.008	0.016	L	0.525	REF	0.021	REF
c	0.080	0.150	0.003	0.006	L1	0.260	0.460	0.010	0.018
D	2.000	2.200	0.079	0.087	θ	0°	8°	0°	8°
E	1.150	1.350	0.045	0.053					

Notes: 1.Controlling dimension: millimeters.  
 2.Maximum lead thickness includes lead finish thickness, and minimum lead thickness is the minimum thickness of base material.  
 3.If there is any question with packing specification or packing method, please contact your local CYStek sales office.

**Material:**

- Lead: Pure tin plated.
- Mold Compound: Epoxy resin family, flammability solid burning class: UL94V-0.

**Important Notice:**

- All rights are reserved. Reproduction in whole or in part is prohibited without the prior written approval of CYStek.
- CYStek reserves the right to make changes to its products without notice.
- CYStek **semiconductor products are not warranted to be suitable for use in Life-Support Applications, or systems.**
- CYStek assumes no liability for any consequence of customer product design, infringement of patents, or application assistance.