

Kit Description

Rev. 1.00 / November 2013

ZSPM8725-KIT

Evaluation Kit for the ZSPM1025C True Digital PWM Controller and the Murata OKLP-X/25-W12-C Power Block



Smart Power Management ICs



Power and Precision

ZSPM8725-KIT

Evaluation Kit for the ZSPM1025C Controller



The Analog Mixed Signal Company



Restrictions:

Zentrum Mikroelektronik Dresden AG's ZSPM8725-KIT Evaluation Kit hardware and the Pink Power Designer™ software are designed only for evaluation of the ZSPM1025C PWM Controller IC and the Murata OKLP-X/25-W12-C Power Block; laboratory setup; and module development. The kit hardware and software must not be used for module production and production test setups.

Zentrum Mikroelektronik Dresden AG (ZMD AG, ZMDI) shall not be liable for any damages arising out of defects resulting from (i) delivered hardware and software, (ii) non-observance of instructions contained in this manual, or (iii) misuse, abuse, use under abnormal conditions, or alteration by anyone other than ZMD AG. To the extent permitted by law, ZMD AG hereby expressly disclaims and User expressly waives any and all warranties, whether express, implied, or statutory, including, without limitation, implied warranties of merchantability and of fitness for a particular purpose, statutory warranty of non-infringement, and any other warranty that may arise by reason of usage of trade, custom, or course of dealing.



Important Safety Warning: These procedures can result in high currents, which can cause severe injury or death. Only trained professional staff should connect external equipment. Ensure that all staff have read and understood this document and the high voltage safety disclaimer that is included with the kit.

Contents

| | | |
|--------|--|----|
| 1 | Introduction..... | 4 |
| 1.1. | Kit Contents | 4 |
| 2 | ZSPM8725 Evaluation Board..... | 5 |
| 2.1. | Evaluation Board Overview | 5 |
| 2.2. | General Setup for the Evaluation System | 7 |
| 2.2.1. | User Instrumentation..... | 8 |
| 2.2.2. | User Computer..... | 8 |
| 3 | Software Installation and Setup..... | 8 |
| 4 | Pink Power Designer™ Software Overview..... | 9 |
| 5 | Evaluation Kit Setup for a 1.2V Output Voltage | 10 |
| 6 | Evaluation Board Hardware Setup..... | 12 |
| 6.1. | Introduction | 12 |
| 6.2. | Output Voltage Selection..... | 12 |
| 6.3. | Output Capacitor Range Selection | 13 |
| 6.3.1. | Output Capacitor Range Test Procedure | 14 |
| 6.4. | On Board Transient Loads | 14 |
| 7 | Support..... | 15 |
| 8 | Related Documents..... | 16 |
| 9 | Definitions of Acronyms..... | 16 |
| 10 | Document Revision History..... | 16 |
| | Appendix A: ZSPM8725 Evaluation Board..... | 17 |
| | Appendix B: ZSPM8725 Evaluation Board Schematic..... | 18 |

ZSPM8725-KIT

Evaluation Kit for the ZSPM1025C Controller



The Analog Mixed Signal Company



List of Figures

| | | |
|------------|--|----|
| Figure 1.1 | ZSPM8725-KIT Evaluation Kit Contents | 4 |
| Figure 2.1 | ZSPM8725-KIT Evaluation Board (Top Side)..... | 6 |
| Figure 2.2 | ZSPM8725-KIT Evaluation Board (Bottom Side) | 7 |
| Figure 2.3 | Pink Power Evaluation Kit Setup | 7 |
| Figure 4.1 | The Pink Power Designer™ GUI | 9 |
| Figure 5.1 | ZSPM8725-KIT – PMBus™ CI Connection (Bottom Side of the PCB) | 11 |
| Figure 5.2 | Control Pin Button..... | 11 |
| Figure 6.1 | J7 - Output Capacitor Range Hardware Selection | 13 |
| Figure 6.2 | J1 and J2 – Transient Load Selection | 14 |
| Figure 6.3 | Timing for the On-Board Transient Loads | 15 |

For more information, contact ZMDI via SPM@zmdi.com.

ZSPM8725-KIT

Evaluation Kit for the ZSPM1025C Controller

ZMDI[®]

The Analog Mixed Signal Company



1 Introduction

This document describes the use of ZMDI's ZSPM8725-KIT for evaluating DC/DC point-of-load (POL) applications and provides additional kit information, including the circuit diagram and board layout. The kit incorporates ZMDI's ZSPM1025C digital PWM controller IC and the Murata OKLP-X/25-W12-C Power Block to form a "smart" buck converter (a.k.a. step-down DC-to-DC converter).

The ZSPM8725-KIT Evaluation Kit hardware functions with the ZSPM1025C Pink Power Designer™ graphical user interface (GUI), which is used for monitoring the internal measurements and fault conditions of the ZSPM1025C. The GUI software must be downloaded to the user's PC from the ZMDI website to ensure receiving the latest release as described in section 3. See section 2.2.2 for the requirements for the user's PC.

The PMBus™ Communication Interface (CI) provides the interface between the ZSPM8725-KIT Evaluation Kit and the user's PC.

1.1. Kit Contents

- ZSPM8725 Evaluation Board
- PMBus™ Communication Interface (CI)
- USB Cable
- *Startup Information* document
- *Safety Disclaimer* document

Figure 1.1 ZSPM8725-KIT Evaluation Kit Contents

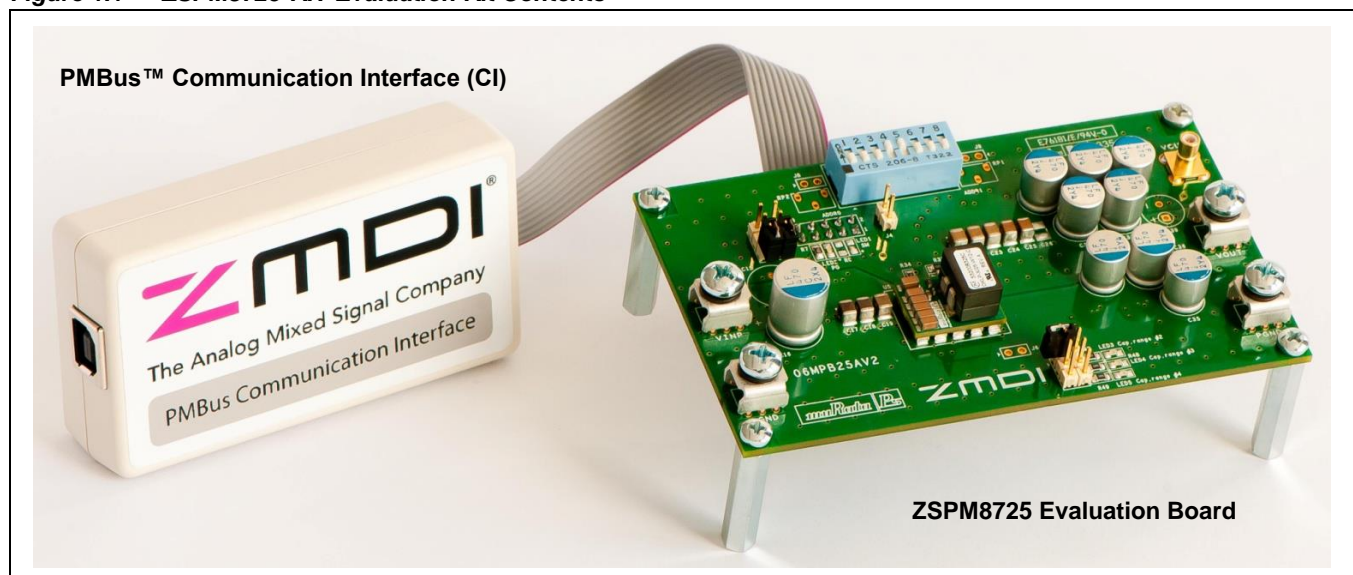



2 ZSPM8725 Evaluation Board

2.1. Evaluation Board Overview

The ZSPM8725 Evaluation Kit provides all the necessary components for a first evaluation of ZMDI's ZSPM1025C digital PWM controller. The ZSPM1025C can be configured using the two pin strap resistors to select the output voltage and the control loop performance. See the *ZSPM1025C Data Sheet* for more details.

In addition to the ZSPM1025C controller, the Evaluation Board features the Murata OKLP-X/25-W12-C Power Block. The number of output capacitors can be selected with a jumper on the Evaluation Board. The electrical specifications can be found in Table 2.1, and the schematic is provided in Appendix B.

Table 2.1 Key Design Parameters for the Evaluation Kit Power Stage

| Parameter | Value |
|------------------------|------------|
| Input voltage | 7 – 13.2V |
| Output voltage | Up to 1.2V |
| Maximum output current | 25A |
| Switching frequency | 500kHz |

The board also provides the connections needed for digital communication between the ZSPM1025C and the GUI software via the PMBus™ Communications Interface (CI).

An on-board transient load is also provided for generating load transients with high current slew rates.

Figure 2.1 shows the ZSPM8725 Evaluation Board and the board connections that will be completed in the subsequent setup steps. Do not make the connections at this point. Note that some settings for the DIP switches are not allowed; therefore, before using the kit, ensure that switches 4 and 5 are in the “ON” position and the rest of the switches are in the “OFF” position as shown in Figure 2.1.

ZSPM8725-KIT

Evaluation Kit for the ZSPM1025C Controller



Figure 2.1 ZSPM8725-KIT Evaluation Board (Top Side)

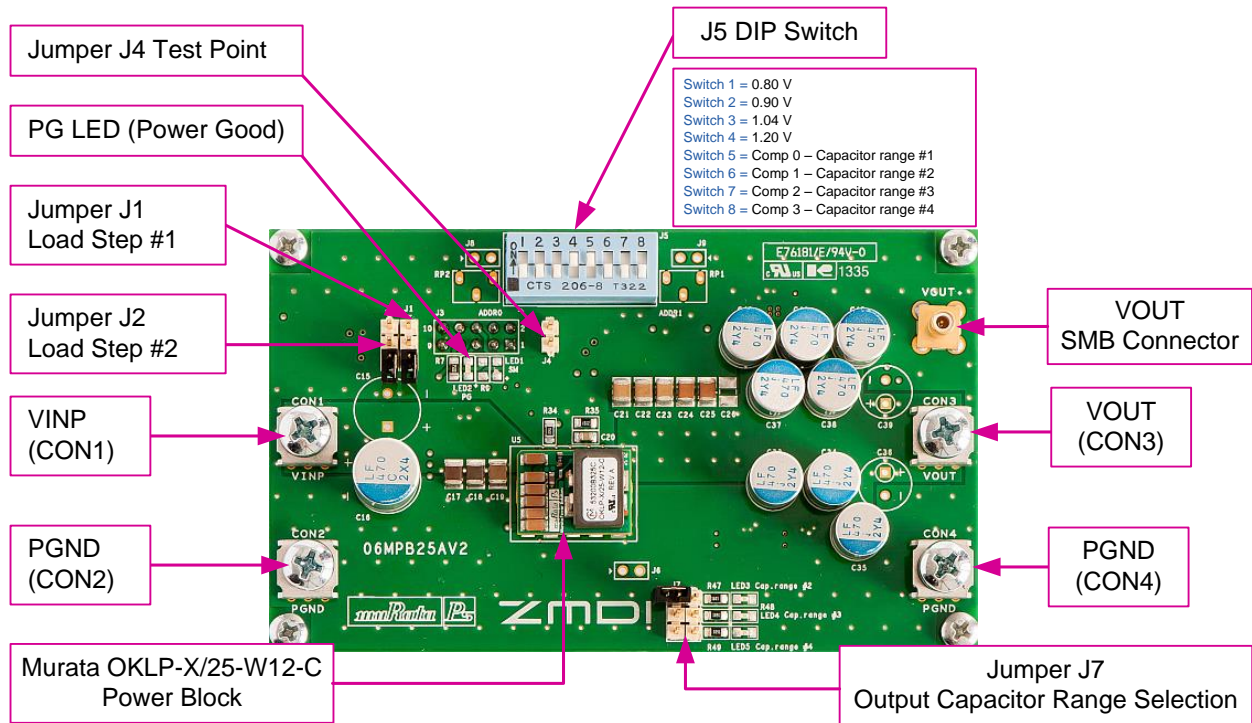

Notes:

- Jumper pins J1 and J2 are used to connect the onboard load transient found on the back of the board. The user can achieve transient load steps by placing a jumper across pins 2 and 3 on J1 and/or J2 (white arrows on the board indicate pin 1). Power resistors in series with the power MOSFETs are used as loads for the load steps, and the current level is therefore output voltage dependent. The load resistors will draw 5A and 10A at the nominal output voltage of 1.2V. Refer to section 6.4 for more information on the transient load circuit.
- Jumper J4 is a test point for the load step (can be used as a trigger for an oscilloscope).
- J5 is a DIP switch used to select configuration resistors for the CONFIG0 and CONFIG1 pins. Ensure that only one switch is on in the set of switches 1 to 4 and only one switch is on in the set of switches 5 to 8.
- Jumper J7 can be used to select the amount of capacitance connected to the output of the Murata OKLP-X/25-W12-C Power Block. Further details provided in section 6.3.
- The SMB connector on the right side of the board is intended for connection to an oscilloscope to provide a low noise measurement of the output voltage.

ZSPM8725-KIT

Evaluation Kit for the ZSPM1025C Controller



Figure 2.2 ZSPM8725-KIT Evaluation Board (Bottom Side)

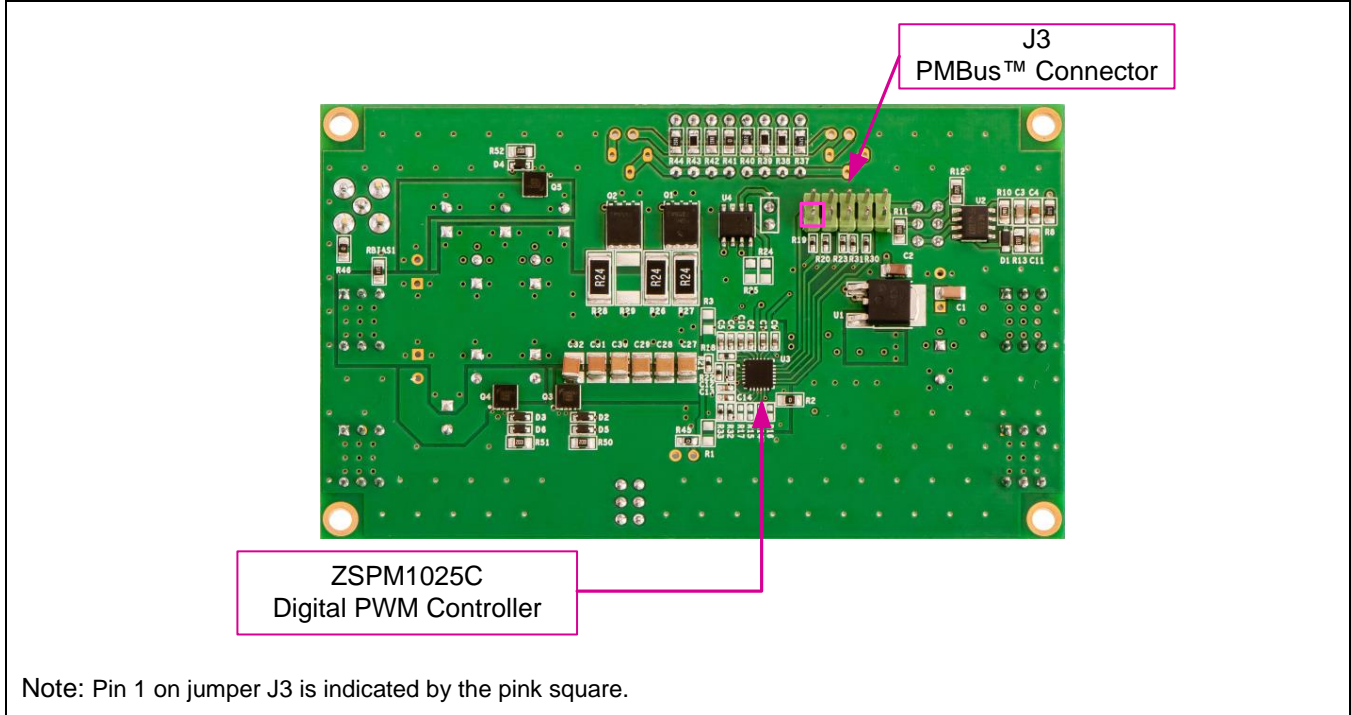

2.2. General Setup for the Evaluation System

The basic setup for using the ZSPM8725 Evaluation Kit is illustrated in Figure 2.3. The pink shaded blocks and the cables are the kit.

Figure 2.3 Pink Power Evaluation Kit Setup

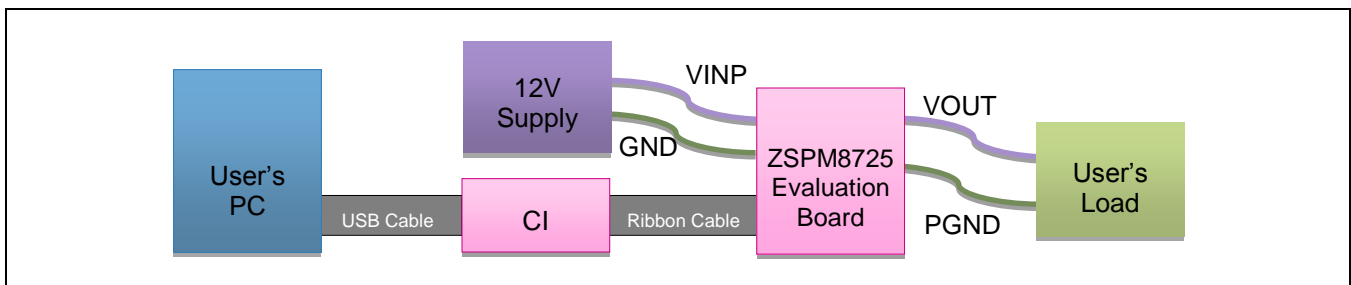



2.2.1. User Instrumentation

The following user equipment is required or recommended for demonstrating the features of the ZSPM1025C controller and the Murata OKLP-X/25-W12-C with the Evaluation Kit:

- **DC power supply:** An external power supply is required for the ZSPM8725 Evaluation Board. Its output voltage must be at least 12V with a rated output current of approximately 1A to 3A depending on the test conditions.
- **Electronic load:** An external DC load is highly recommended as the Evaluation Board features only transient loads due to constraints in power dissipation. While an electronic load can be very advantageous, load resistors could also be sufficient for testing. Ensure that the electronic load has an adequate power rating.
- **Oscilloscope:** Connecting an oscilloscope to the Evaluation Kit is strongly recommended for measuring the performance of the Evaluation Board in the time domain. The Evaluation Board features an SMB connector connected to the output of the power stage for easy connection to an oscilloscope.

2.2.2. User Computer

A Windows®-based computer (PC) is required for interfacing with the ZSPM8725 Evaluation Board through the PMBus™ Communication Interface. The user will need administrative rights on the PC to download and install the Pink Power Designer™ GUI for the kit. The PC must meet the following requirements:

- Windows® XP or Windows® 7
- Internet access

3 Software Installation and Setup

The software for the ZSPM8725 KIT is the ZSPM1025C Pink Power Designer™ graphical user interface (GUI), which is required to monitor the internal measurement and fault conditions of the ZSPM1025C. The Pink Power Designer™ must be downloaded from the ZSPM1025C product page on ZMDI's website located at www.zmdi.com/ZSPM1025c.

1. Extract the executable file *ZMDI_ZSPM1025_PPDGui_X.x.y_win32-setup.exe* from the zip file.
2. Install the Pink Power Designer™ GUI software by clicking on *ZMDI_ZSPM1025_PPDGui_X.x.y_win32-setup.exe*.



4 Pink Power Designer™ Software Overview

This section gives a brief introduction to the Pink Power Designer™ software. For full instructions for using the software, refer to the *Pink Power Designer™ Graphic User Interface (GUI) for the ZSPM1025C/D*, which is included in the software and can also be downloaded from the ZSPM1025C product page on ZMDI's web site (www.zmdi.com/ZSPM1025c). To open it, click "Help" on the top menu of the Pink Power Designer™ GUI and then click "User Guide" (see Figure 4.1).

The Pink Power Designer™ is a graphic user interface (GUI) designed by ZMDI to enable the user to monitor the internal measurements and fault conditions on the evaluation or application board. The Pink Power Designer™ GUI includes a wizard which will guide the user through a simple selection process to select the controller under test. The display is structured with a main window and a side panel on the left side for status information.

Figure 4.1 The Pink Power Designer™ GUI

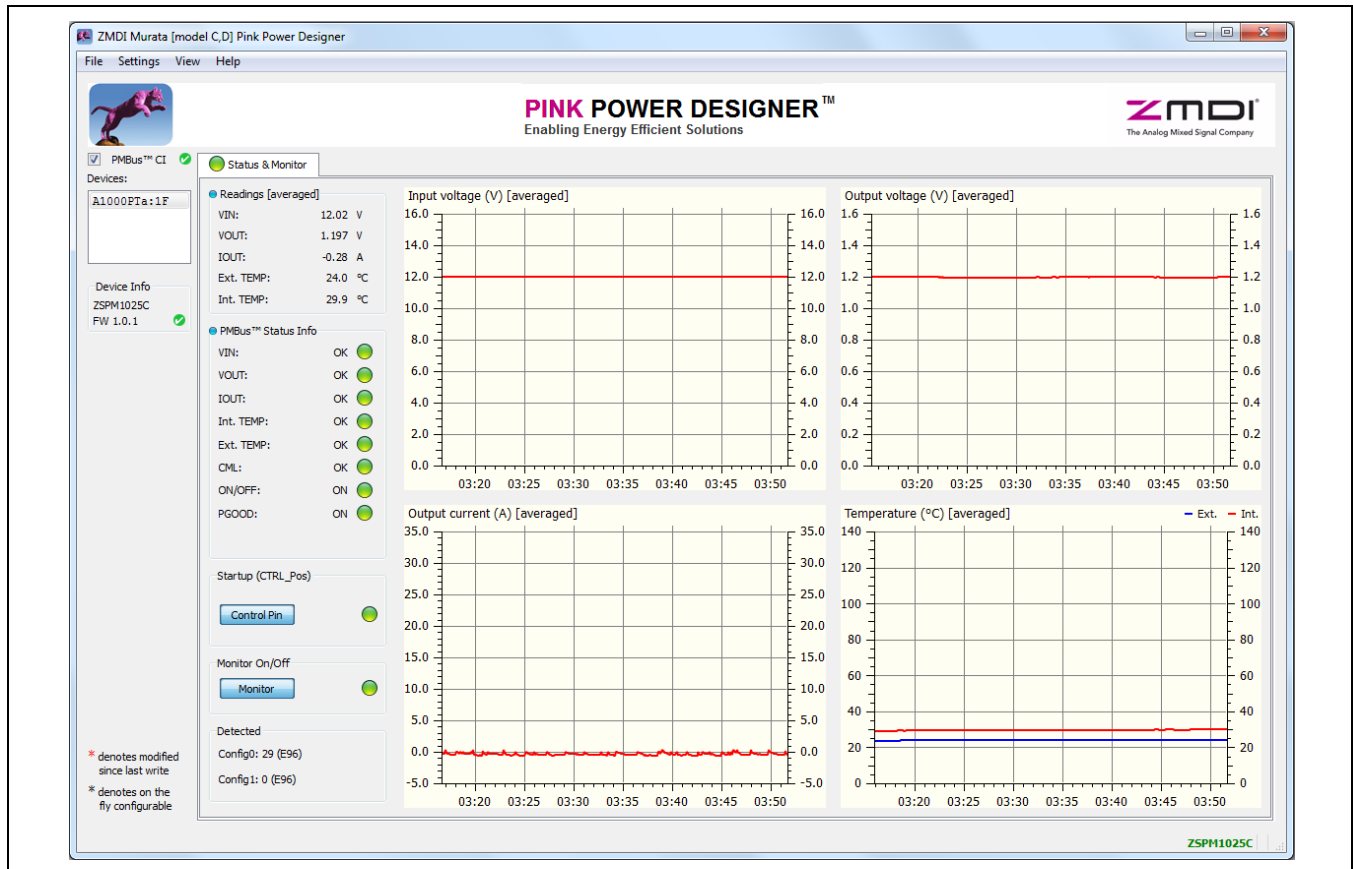



The “Murata Power Block” Wizard

Upon start-up of the GUI, a wizard will guide the user through a simple selection process. The wizard will select the correct configuration data for the ZSPM1025C controller.

The Side Panel

The side panel provides information about the status of the PMBus™ CI and the device connected to the PMBus™ CI.

The Status & Monitor Tab

The “Status & Monitor” provides monitoring of voltage, current, and temperatures. The status of the internal fault monitoring is shown.

The CONTROL pin of the ZSPM1025C can be toggled to enable or disable the output of the ZSPM8725 Evaluation Board. The pin strap configuration indexes for the CONFIG0 and CONFIG1 are displayed in the bottom left corner.

5 Evaluation Kit Setup for a 1.2V Output Voltage

This section covers the steps for powering up the ZSPM8725 Evaluation Kit for the first time.



Important Safety Warning: The following procedures can result in high currents, which can cause severe injury or death. Only trained professional staff should connect external equipment. Do not enable the power supply connected to the input terminals until indicated in the following steps.

Follow this step-by-step instruction to power up the ZSPM8725 Evaluation Board:

- Step 1:** Set switches 4 and 5 on DIP switch J5 to ON and make sure no jumper is placed on header J7. The remainder of the switches must be in the OFF position. This selects the standard configuration for the ZSPM8725 Evaluation Board. The standard configuration has an output voltage of 1.2V and operates with the lowest output capacitor range.
- Step 2:** Connect the power supply to the connectors labeled CON1 (VINP in Figure 2.1) and CON2 (PGND). Connect the load to the CON3 (VOUT) and CON4 (PGND) connectors. The load can be either a resistor or an electronic load. Connect the PMBus™ CI to connector J3 (see Figure 5.1) and to a USB port on the user’s PC.
- Step 3:** Start the Pink Power Designer™ and follow the instructions given in *Pink Power Designer™ Graphic User Interface (GUI) Guide for the ZSPM1025C/D* to select the Murata OKLP-X/25-W12-C Power Block and the ZSPM1025C controller via the Murata Power Block Wizard. Then click “Finish” to proceed to the main window of the GUI.

ZSPM8725-KIT

Evaluation Kit for the ZSPM1025C Controller



Step 4: Set the power supply voltage to 12V and enable the output of the power supply. If the power supply has no enable button make sure that the output voltage is set to 12V before connecting it to the ZSPM8725 Evaluation Board. The Pink Power Designer™ GUI will now recognize the ZSPM1025C and show the device in the status panel on the left hand side of the screen.

Note: Because the ZSPM1025C has not yet been enabled by the GUI, there should be no voltage present on the output connectors of the ZSPM8725 Evaluation Board at this time.

Step 5: Make sure that monitoring of the input voltage, output voltage, output current, and the readings of internal and external temperature is active. The virtual LED next to the “Monitor” button will be green when monitoring is enabled (see Figure 5.2). Click on the “Monitor” button to enable monitoring if the virtual LED is not green.

Step 6: Click on the “Control Pin” button located in the “Startup” subsection to enable the output of the ZSPM8725 Evaluation Board. The power-good (PG) LED on the board should be on now (see Figure 2.1) and a voltage of 1.2V should be present on the output terminals.

Figure 5.1 ZSPM8725-KIT – PMBus™ CI Connection (Bottom Side of the PCB)

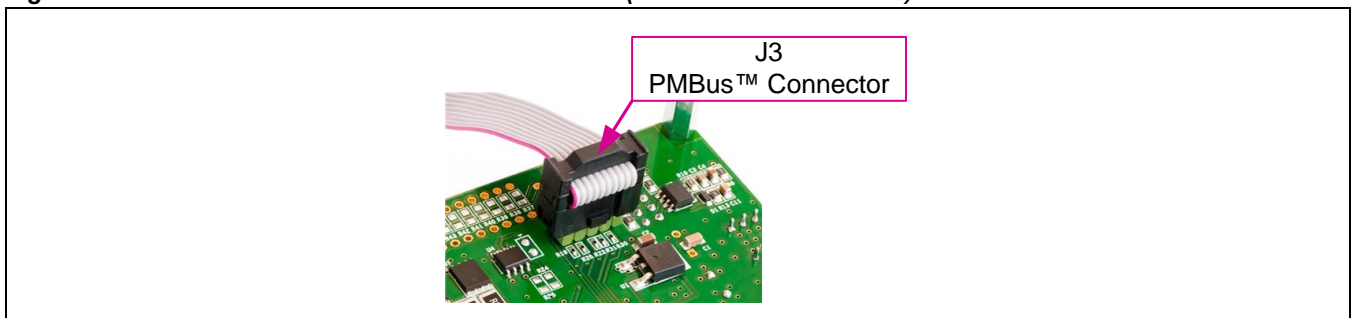
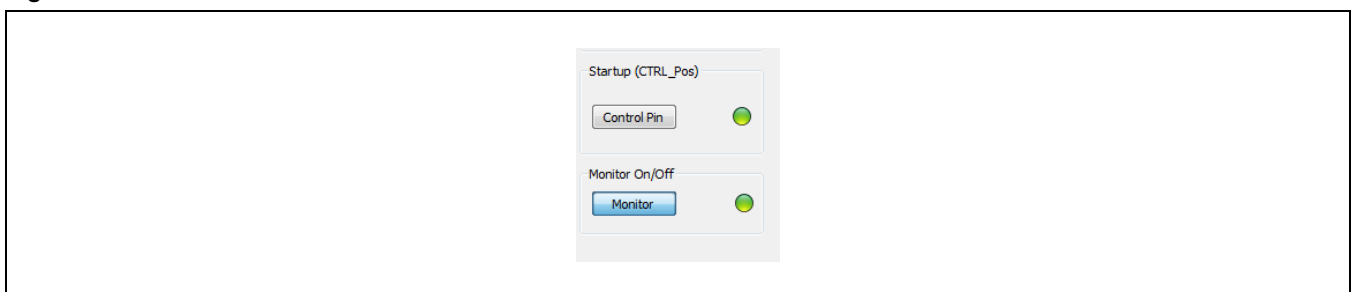

Figure 5.2 Control Pin Button





6 Evaluation Board Hardware Setup

6.1. Introduction

The ZSPM1025C PWM controller has two configuration pins that support pin strapping of the following parameters:

- Output Voltage, VOUT
- Compensation Loop Parameters
- Output Voltage Slew Rate (always set to 10 V/ms on the ZSPM8725 Evaluation Board)

The output voltage is set with a pin strap resistor between the CONFIG0 pin and the AGND pin of the ZSPM1025C that is selected with the J5 DIP switch. Refer to section 6.2 for more information on the output voltage selection on the ZSPM8725 Evaluation Board. The *ZSPM1025C Data Sheet* provides detailed information about the output voltage selection of the ZSPM1025C.



The ZSPM1025C has four pre-configured compensators that are selectable with a pin strap resistor between the CONFIG1 pin and AGND that is selected with the J5 DIP switch. The four compensators have been designed to work for specific ranges of output capacitors. Section 6.3 describes how the Evaluation Board can be configured for any of the four capacitor ranges, thereby enabling simple comparisons of the dynamic performance of the complete solution. The *ZSPM1025C Data Sheet* provides further information about the compensation loop configurations of the ZSPM1025C controller and typical performance measurements.

6.2. Output Voltage Selection

The ZSPM1025C has been pre-configured for 30 different output voltages (see the *ZSPM1025C Data Sheet*) selectable by a pin strap resistor between the CONFIG0 pin and AGND. Four common output voltages can be selected with DIP switch J5 on the ZSPM8725 Evaluation Board.

Important: Ensure that for the set of switches 1 through 4 on DIP switch J5, only one switch is in the ON position.

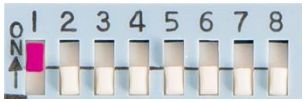
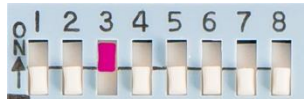
Table 6.1 ZSPM8725 Evaluation Board - Output Voltage Selection

| Output Voltage VOUT | DIP Switch J5 | Output Voltage VOUT | DIP Switch J5 |
|---------------------|---|---------------------|---|
| 0.80V |  | 1.04V |  |
| 0.90V |  | 1.20V |  |

Follow these steps to change the output voltage:

1. Make sure that the input voltage for the ZSPM8725 evaluation board is OFF
2. Select the nominal output voltage by setting the DIP switch corresponding to the required output voltage to the “ON” position. Ensure that the three remaining DIP switches are in the “OFF” position
3. Apply the input voltage to the ZSPM8725 Evaluation Board
4. Enable the output voltage by clicking the “Control Pin” in the Pink Power Designer GUI™



6.3. Output Capacitor Range Selection

The ZSPM1025C controllers have been pre-configured with four sets of compensation loop parameters. Each set of compensation parameters has been designed to match a range of output capacitor (see the *ZSPM1025C Data Sheet* for more information on the output capacitor ranges). The Evaluation Board enables the customer to test the performance of the controller for each of the four output capacitor ranges. A minimum of ceramic capacitors are always present on the output of the Murata OKLP-X/25-W12-C Power Block (capacitor range #1, no jumper on J7) and further capacitor banks can be selected with a jumper on header J7 (see Table 6.2). The type and number of capacitors connected to the output for each range are listed in Table 6.2. On the Evaluation Board, one of the three LEDs adjacent to J7 will turn green to indicate if capacitor range #2, #3, or #4 has been selected (see Figure 6.1). If none of the LEDs are on, it means that capacitor range #1 has been selected.

Figure 6.1 J7 - Output Capacitor Range Hardware Selection

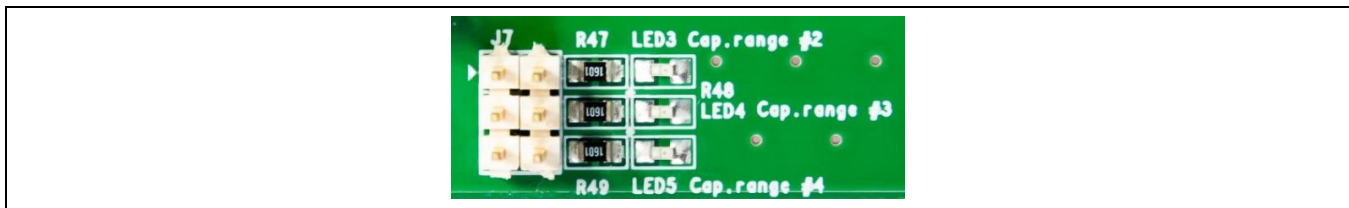

It is important to ensure that the output capacitor range selected on J7 matches the compensator selected for the ZSPM1025C. The compensator can be selected on DIP switch J5 on switches 5 through 8 (see Table 6.2).

Important: Ensure that for the set of switches 5 through 8 on DIP switch J5, only one switch is in the ON position.

The output voltage slew rate is always set to 10 V/ms on the ZSPM8725 Evaluation Board.

Table 6.2 ZSPM8725 Evaluation Board – Output Capacitor Range Selection

| Capacitor Range | Ceramic Capacitor | Bulk Electrolytic Capacitors | Header J7 | DIP Switch J5 |
|-----------------|--|------------------------------|-----------|-------------------|
| #1 | 3 x 100µF 6.3V X5R 2 x 47µF 10V X7R | None | | Comp0 Setting |
| #2 | 7 x 100µF 6.3V X5R 4 x 47µF 10V X7R | None | | Comp1 Setting |
| #3 | 3 x 100µF 6.3V X5R 2 x 47µF 10V X7R | 3 x 470µF, 7mΩ ESR | | Comp2 Setting |
| #4 | 7 x 100µF 6.3V X5R 4 x 47µF 10V X7R | 8 x 470µF, 7mΩ ESR | | Comp3 Setting |



6.3.1. Output Capacitor Range Test Procedure

To test the performance of the four selectable compensators, follow these simple steps:

1. Make sure that the input voltage for the ZSPM8725 evaluation board is OFF.
2. Select the output capacitor range via header J7.
3. Select the compensator matching the output capacitor range using positions 5 through 8 on the J5 DIP switch.
4. Select the nominal output voltage using positions 1 through 4 on the J5 DIP switch.
5. Apply the input voltage to the ZSPM8725 Evaluation Board.
6. Enable the output voltage by clicking the “Control Pin” in the Pink Power Designer GUI™.
7. Test the dynamic performance using either the on-board transient loads or an external electronic load.

6.4. On Board Transient Loads

The ZSPM8725 Evaluation Board has on-board transient loads that can be used to test the dynamic performance of the ZSPM1025C controller. The transient loads consist of a simple timer circuit driving the power MOSFET. The power MOSFET is connected in series with resistors connected across the output of the Murata OKLP-X/25-W12-C Power Block. A schematic of the transient load circuitry is provided in Appendix B.

There are two transient loads that can be enabled on headers J1 and J2 respectively (see Figure 6.2). The two loads can be enabled at the same time to achieve a larger current step. The timing signal for the transient loads has an ON time of approximately 1 millisecond with a time period of approximately 80 milliseconds (see Figure 6.3).

Important: The load current is a function of the nominal output voltage set on DIP switch J5 and the resistance of the transient load. Be sure to calculate the expected load current before enabling the transient loads.

Figure 6.2 J1 and J2 – Transient Load Selection

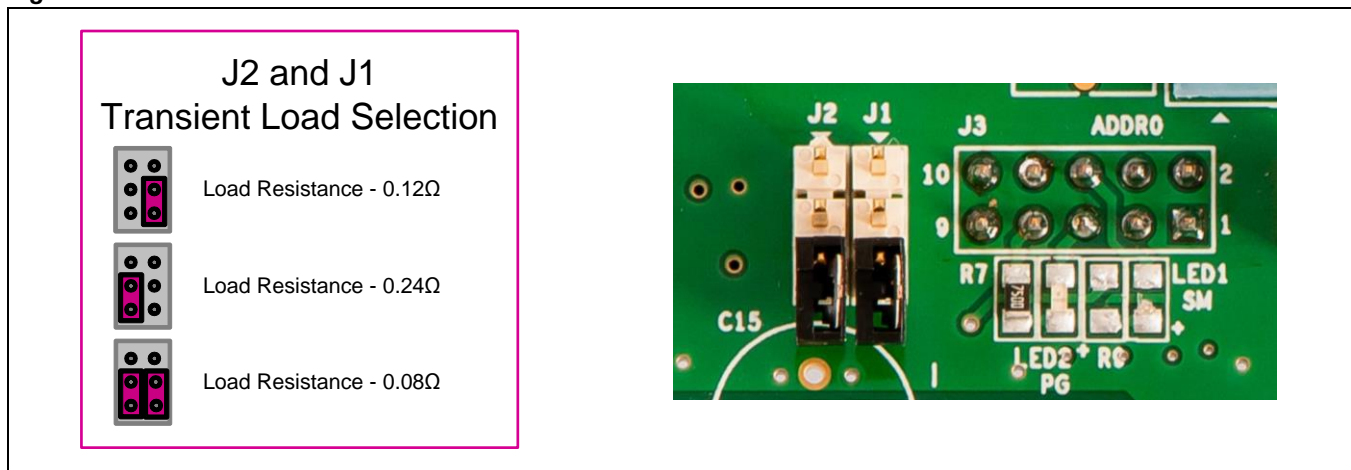
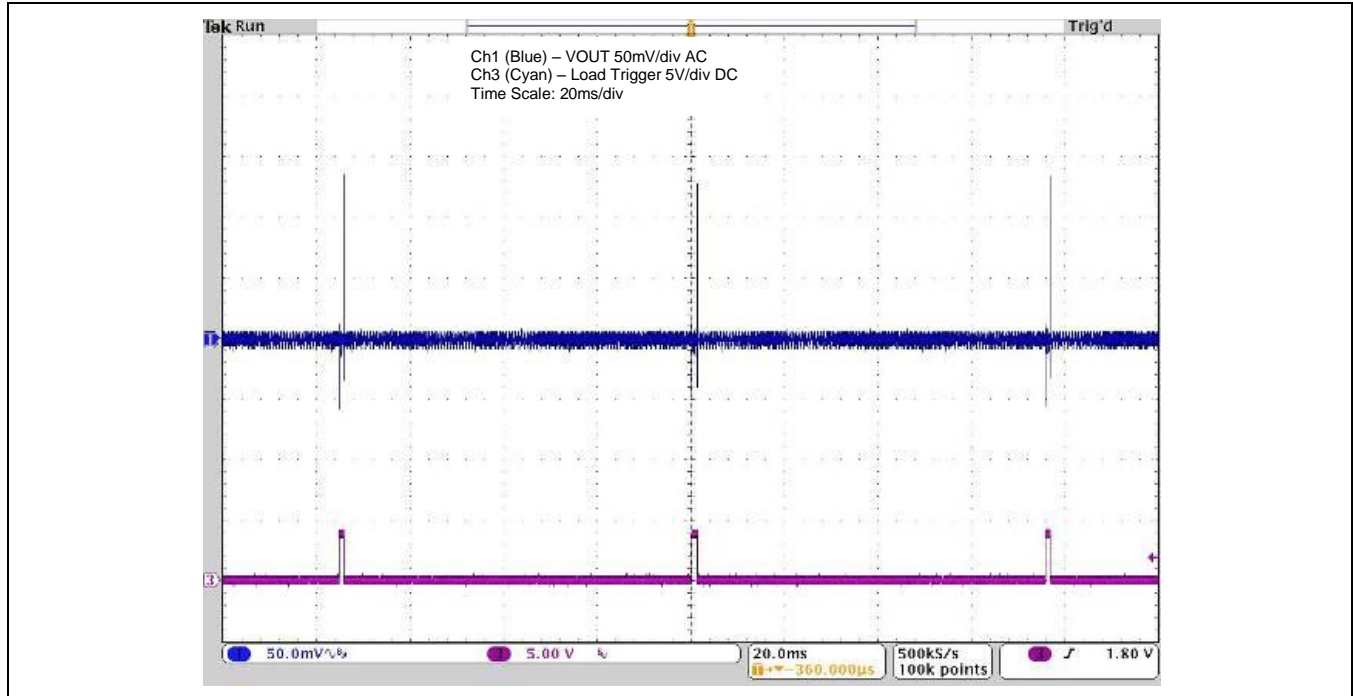



Figure 6.3 Timing for the On-Board Transient Loads



7 Support

ZMDI provides additional support tools for the ZSPM8725-KIT and the ZMDI Pink Power Designer™ on the www.zmdi.com/murata_power_block webpage. If further support is needed, contact ZMDI (also see contact information table on page 16):

Phone: +49 (351) 88227 776

Email: spm@zmdi.com

ZSPM8725-KIT

Evaluation Kit for the ZSPM1025C Controller



The Analog Mixed Signal Company



8 Related Documents

Note: X_xy refers to the current revision of the document.

| Document | File Name |
|---|--|
| ZSPM1025C Data Sheet | ZSPM1025CD_Data_Sheet_Rev_X_xy.pdf |
| Pink Power Designer™ Graphic User Interface (GUI) Guide for the ZSPM1025C/D | ZSPM1025C-D_PPD_GUI_UserGuide_Rev_X_xy.pdf |

Visit the ZSPM1025C product page at www.zmdi.com/zspm1025c on ZMDI's website www.zmdi.com or contact your nearest sales office for the latest version of these documents.

9 Definitions of Acronyms

| Term | Description |
|------|------------------------|
| DIP | Dual In-line Package |
| PWM | Pulse Width Modulation |

10 Document Revision History

| Revision | Date | Description |
|----------|-------------------|----------------|
| 1.00 | November 26, 2013 | First release. |

| Sales and Further Information | | www.zmdi.com | SPM@zmdi.com | |
|--|--|---|--|--|
| Zentrum Mikroelektronik Dresden AG Global Headquarters Grenzstrasse 28 01109 Dresden, Germany Central Office: Phone +49.351.8822.0 Fax +49.351.8822.600 | ZMD America, Inc. 1525 McCarthy Blvd., #212 Milpitas, CA 95035-7453 USA USA Phone +855.275.9634 Phone +408.883.6310 Fax +408.883.6358 | Zentrum Mikroelektronik Dresden AG, Japan Office 2nd Floor, Shinbashi Tokyu Bldg. 4-21-3, Shinbashi, Minato-ku Tokyo, 105-0004 Japan Phone +81.3.6895.7410 Fax +81.3.6895.7301 | ZMD FAR EAST, Ltd. 3F, No. 51, Sec. 2, Keelung Road 11052 Taipei Taiwan Phone +886.2.2377.8189 Fax +886.2.2377.8199 | Zentrum Mikroelektronik Dresden AG, Korea Office U-space 1 Building 11th Floor, Unit JA-1102 670 Sampyeong-dong Bundang-gu, Seongnam-si Gyeonggi-do, 463-400 Korea Phone +82.31.950.7679 Fax +82.504.841.3026 |
| European Technical Support Phone +49.351.8822.7.772 Fax +49.351.8822.87.772 | DISCLAIMER: This information applies to a product under development. Its characteristics and specifications are subject to change without notice. Zentrum Mikroelektronik Dresden AG (ZMD AG) assumes no obligation regarding future manufacture unless otherwise agreed to in writing. The information furnished hereby is believed to be true and accurate. However, under no circumstances shall ZMD AG be liable to any customer, licensee, or any other third party for any special, indirect, incidental, or consequential damages of any kind or nature whatsoever arising out of or in any way related to the furnishing, performance, or use of this technical data. ZMD AG hereby expressly disclaims any liability of ZMD AG to any customer, licensee or any other third party, and any such customer, licensee and any other third party hereby waives any liability of ZMD AG for any damages in connection with or arising out of the furnishing, performance or use of this technical data, whether based on contract, warranty, tort (including negligence), strict liability, or otherwise. | | | |
| European Sales (Stuttgart) Phone +49.711.674517.55 Fax +49.711.674517.87955 | | | | |

| | | |
|---|---|----------|
| Kit Description November 26, 2013 | © 2013 Zentrum Mikroelektronik Dresden AG — Rev. 1.00 All rights reserved. The material contained herein may not be reproduced, adapted, merged, translated, stored, or used without the prior written consent of the copyright owner. The information furnished in this publication is subject to changes without notice. | 16 of 19 |
|---|---|----------|

ZSPM8725-KIT

Evaluation Kit for the ZSPM1025C Controller



Appendix A: ZSPM8725 Evaluation Board

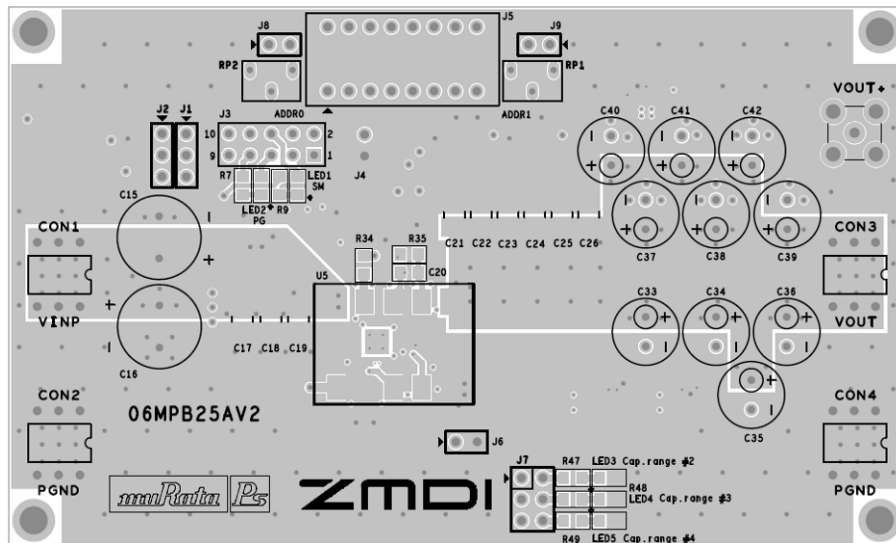

Top side

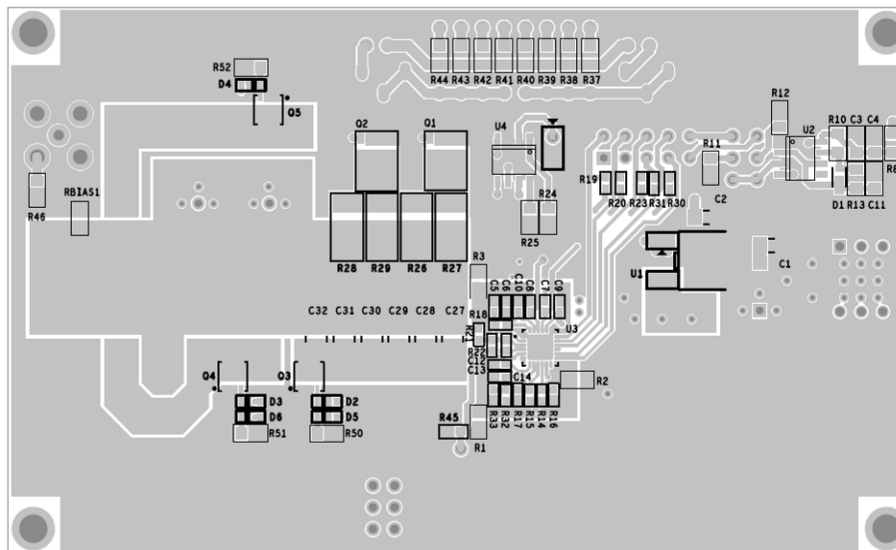

Bottom Side

ZSPM8725-KIT

Evaluation Kit for the ZSPM1025C Controller



The Analog Mixed Signal Company



Appendix B: ZSPM8725 Evaluation Board Schematic

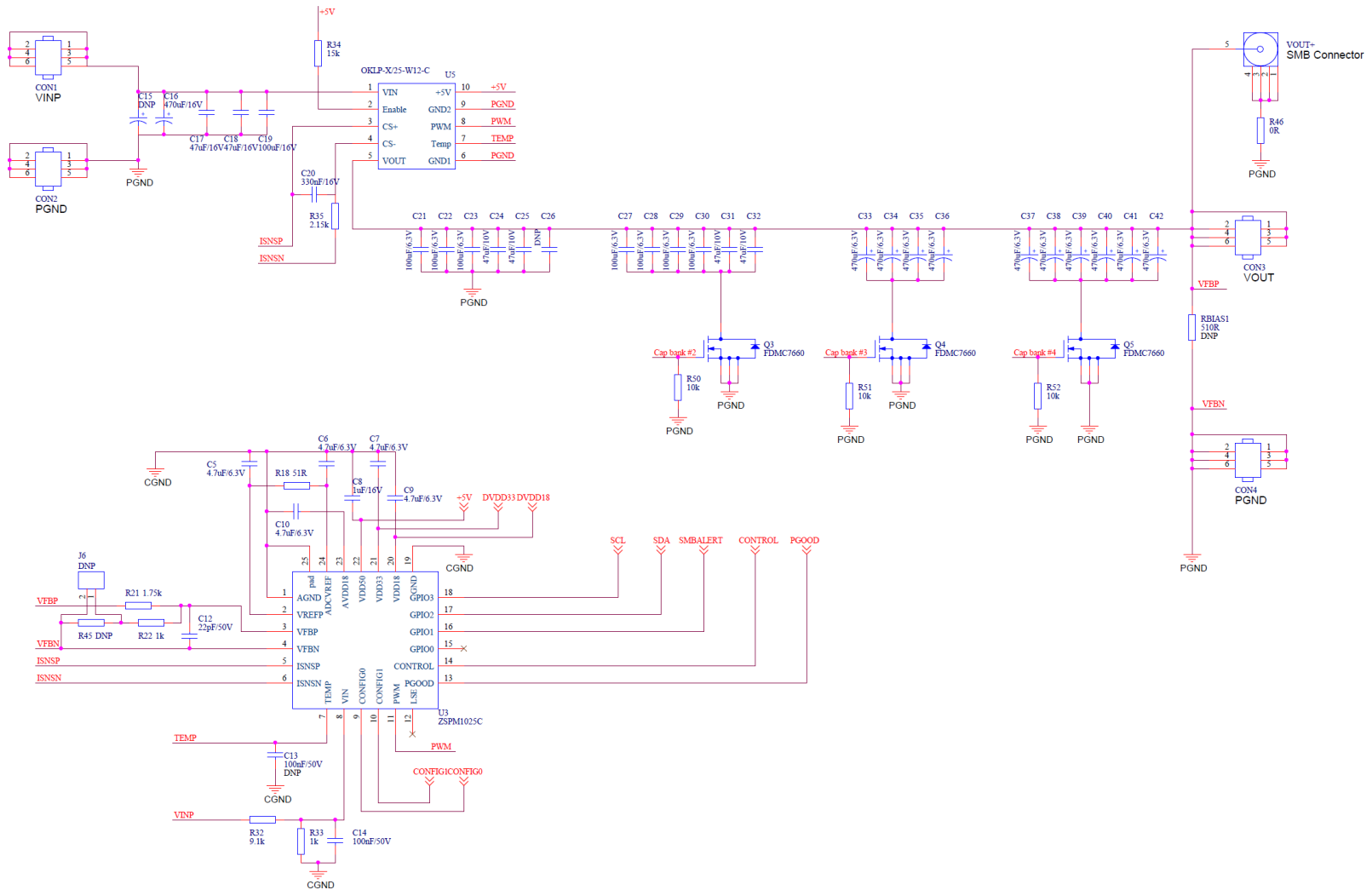

ZSPM8725-KIT

Evaluation Kit for the ZSPM1025C Controller



The Analog Mixed Signal Company

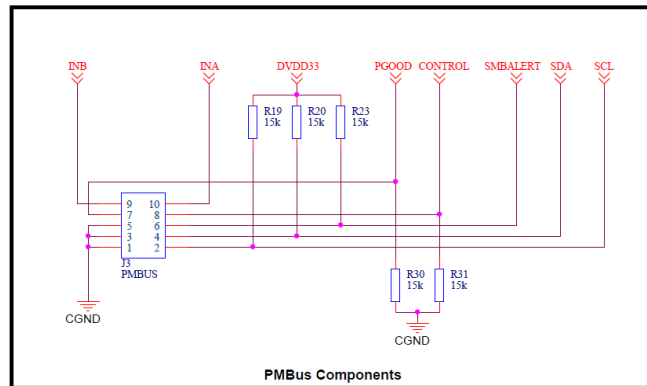
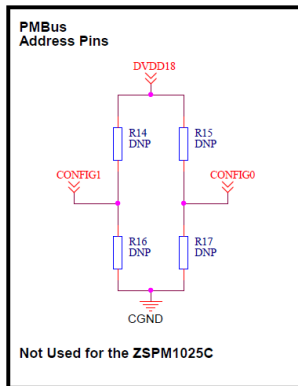
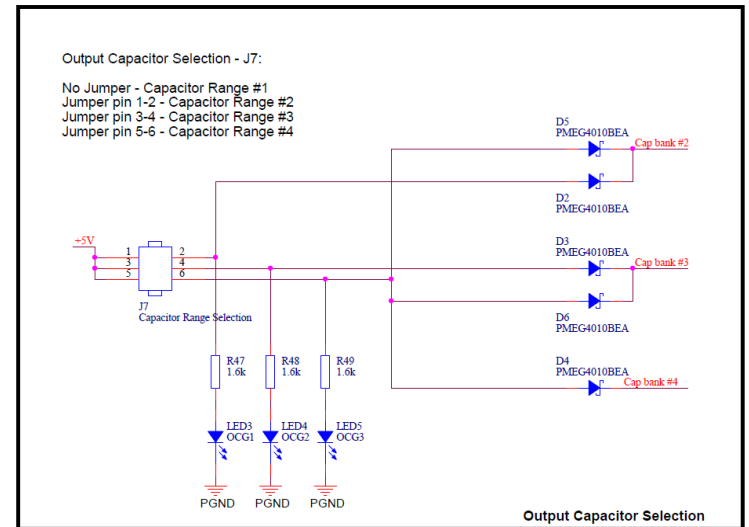
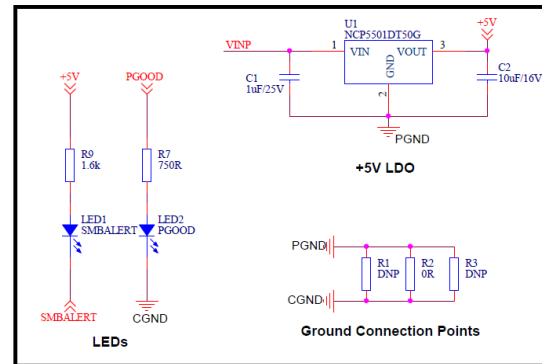
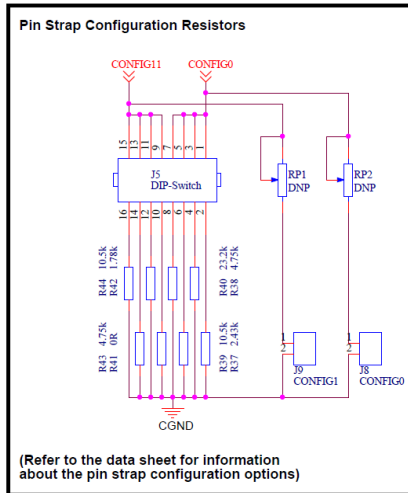
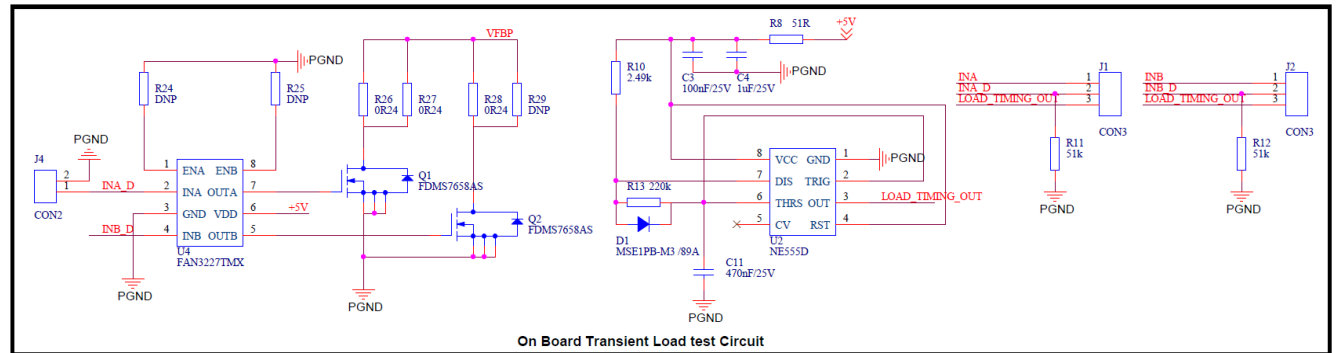

Mouser Electronics

Authorized Distributor

Click to View Pricing, Inventory, Delivery & Lifecycle Information:

[ZMDI:](#)

[ZSPM8725 KIT](#)