

# TC7SH08F, TC7SH08FU

## Features

- High speed operation :  $t_{pd} = 4.3\text{ns}$  (typ.) at  $V_{CC} = 5\text{V}$ , 15pF
- Low power dissipation :  $I_{CC} = 2\ \mu\text{A}$  (max) at  $T_a = 25^\circ\text{C}$
- High noise immunity :  $V_{NIH} = V_{NIL} = 28\% V_{CC}$  (min)
- 5.5-V tolerant inputs
- Wide operating voltage range :  $V_{CC} = 2$  to  $5.5\ \text{V}$

## Marking

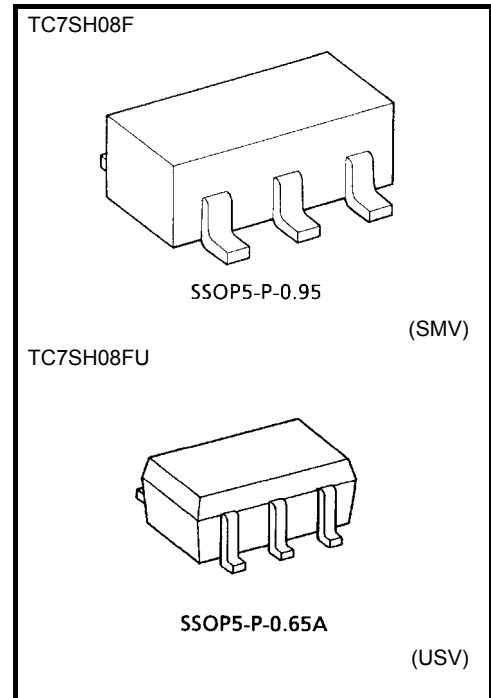
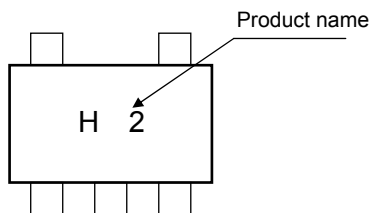

### Weight

SSOP5-P-0.95 : 0.016 g (typ.)  
SSOP5-P-0.65A : 0.006 g (typ.)

## Absolute Maximum Ratings ( $T_a = 25^\circ\text{C}$ )

Characteristics	Symbol	Rating	Unit
Supply voltage	$V_{CC}$	- 0.5 to 7	V
DC input voltage	$V_{IN}$	- 0.5 to 7	V
DC output voltage	$V_{OUT}$	- 0.5 to $V_{CC} + 0.5$	V
Input diode current	$I_{IK}$	- 20	mA
Output diode current	$I_{OK}$	$\pm 20$ (Note1)	mA
DC output current	$I_{OUT}$	$\pm 25$	mA
DC $V_{CC}$ /ground current	$I_{CC}$	$\pm 50$	mA
Power dissipation	$P_D$	200	mW
Storage temperature	$T_{stg}$	- 65 to 150	$^\circ\text{C}$
Lead temperature (10 s)	$T_L$	260	$^\circ\text{C}$

## Pin Assignment (top view)

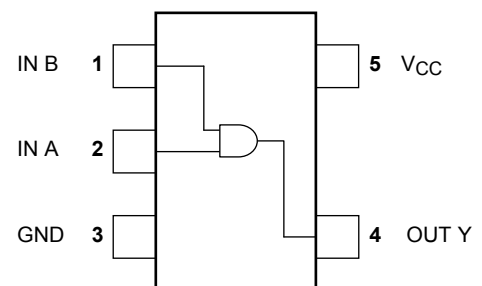

Note: Using continuously under heavy loads (e.g. the application of high temperature/current/voltage and the significant change in temperature, etc.) may cause this product to decrease in the reliability significantly even if the operating conditions (i.e. operating temperature/current/voltage, etc.) are within the absolute maximum ratings and the operating ranges.

Please design the appropriate reliability upon reviewing the TY Semiconductor Reliability Handbook ("Handling Precautions"/"Derating Concept and Methods") and individual reliability data (i.e. reliability test report and estimated failure rate, etc).

Note1:  $V_{OUT} < GND$ ,  $V_{OUT} > V_{CC}$

# TC7SH08F, TC7SH08FU

## IEC Logic Symbol

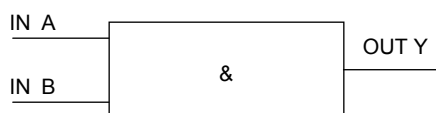

## Truth Table

A	B	Y
L	L	L
L	H	L
H	L	L
H	H	H

## Operating Ranges

Characteristics	Symbol	Rating	Unit
Supply voltage	$V_{CC}$	2.0 to 5.5	V
Input voltage	$V_{IN}$	0 to 5.5	V
Output voltage	$V_{OUT}$	0 to $V_{CC}$	V
Operating temperature	$T_{opr}$	-40 to 85	°C
Input rise and fall time	dt/dv	0 to 100 ( $V_{CC} = 3.3 \pm 0.3V$ )	ns/V
		0 to 20 ( $V_{CC} = 5.0 \pm 0.5V$ )	

# TC7SH08F, TC7SH08FU

## Electrical Characteristics

### DC Characteristics

Characteristics	Symbol	Test Condition		Ta = 25°C			Ta = -40 to 85°C		Unit	
				V <sub>CC</sub> (V)	Min	Typ.	Max	Min		Max
High-level input voltage	V <sub>IH</sub>	—		2.0	1.5	—	—	1.5	—	V
				3.0 to 5.5	V <sub>CC</sub> × 0.7	—	—	V <sub>CC</sub> × 0.7	—	
Low-level input voltage	V <sub>IL</sub>	—		2.0	—	—	0.5	—	0.5	V
				3.0 to 5.5	—	—	V <sub>CC</sub> × 0.3	—	V <sub>CC</sub> × 0.3	
High-level output voltage	V <sub>OH</sub>	V <sub>IN</sub> = V <sub>IH</sub>	I <sub>OH</sub> = -50 μA	2.0	1.9	2.0	—	1.9	—	V
				3.0	2.9	3.0	—	2.9	—	
				4.5	4.4	4.5	—	4.4	—	
			I <sub>OH</sub> = -4 mA	3.0	2.58	—	—	2.48	—	
				4.5	3.94	—	—	3.80	—	
Low-level output voltage	V <sub>OL</sub>	V <sub>IN</sub> = V <sub>IH</sub> or V <sub>IL</sub>	I <sub>OL</sub> = 50 μA	2.0	—	0	0.10	—	0.10	V
				3.0	—	0	0.10	—	0.10	
				4.5	—	0	0.10	—	0.10	
			I <sub>OL</sub> = 4 mA	3.0	—	—	0.36	—	0.44	
				4.5	—	—	0.36	—	0.44	
Input leakage current	I <sub>IN</sub>	V <sub>IN</sub> = 5.5 V or GND		0 to 5.5	—	—	±0.1	—	±1.0	μA
Quiescent supply current	I <sub>CC</sub>	V <sub>IN</sub> = V <sub>CC</sub> or GND		5.5	—	—	2.0	—	20.0	μA

# TC7SH08F, TC7SH08FU

## AC Characteristics (unless otherwise specified, Input: $t_r = t_f = 3$ ns)

Characteristics	Symbol	Test Condition		Ta = 25°C			Ta = -40 to 85°C		Unit
		V <sub>CC</sub> (V)	C <sub>L</sub> (pF)	Min	Typ.	Max	Min	Max	
Propagation delay time	t <sub>PLH</sub>	3.3 ± 0.3	15	—	6.2	8.8	1.0	10.5	ns
			50	—	8.7	12.3	1.0	14.0	
	t <sub>PHL</sub>	5.0 ± 0.5	15	—	4.3	5.9	1.0	7.0	
			50	—	5.8	7.9	1.0	9.0	
Input capacitance	C <sub>IN</sub>	—		—	4	10	—	10	pF
Power dissipation capacitance	C <sub>PD</sub>	(Note 2)		—	14	—	—	—	pF

Note 2: C<sub>PD</sub> is defined as the value of the internal equivalent capacitance which is calculated from the operating current consumption without load.

Average operating current can be obtained by the equation:

$$I_{CC(opr.)} = C_{PD} \cdot V_{CC} \cdot f_{IN} + I_{CC}$$

# TC7SH08F, TC7SH08FU

## Package Dimensions

SSOP5-P-0.95

Unit : mm

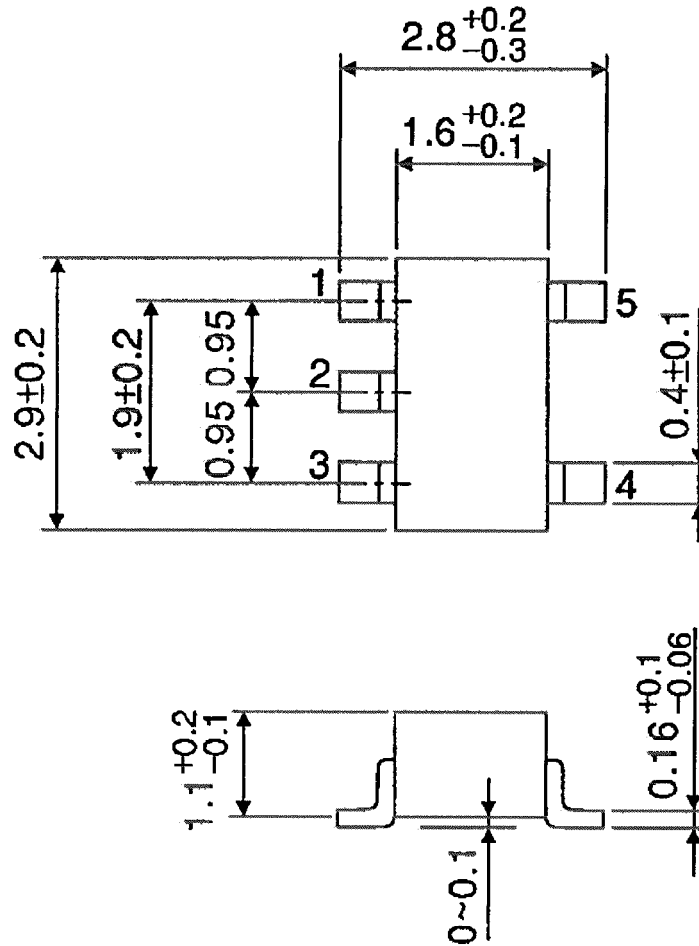

Weight: 0.016 g (typ.)

# TC7SH08F, TC7SH08FU

## Package Dimensions

SSOP5-P-0.65A

Unit : mm

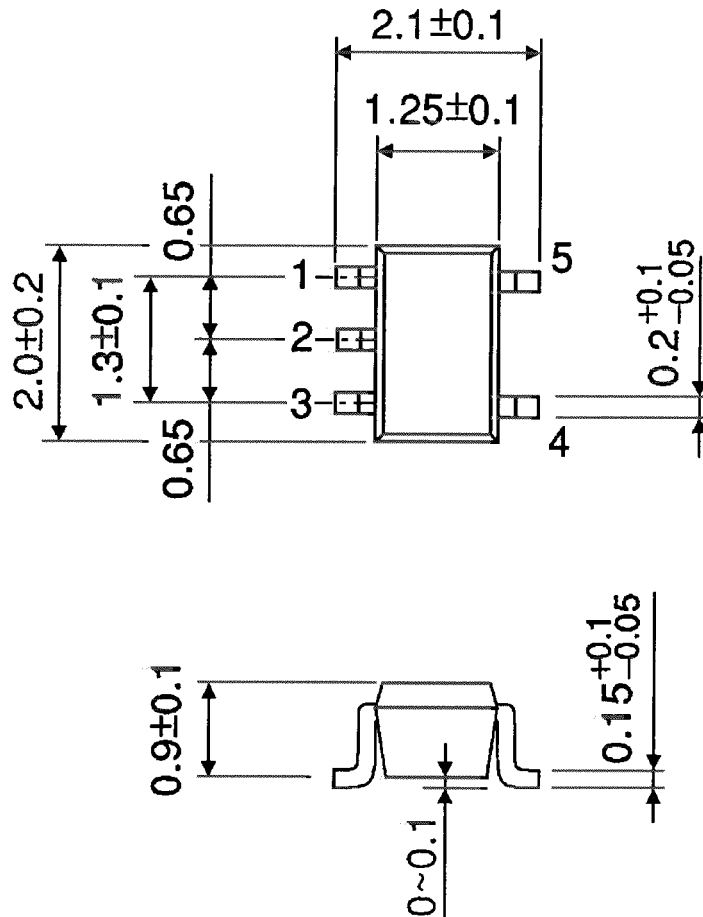

Weight: 0.006 g (typ.)