

▲ CIRCUIT: SPST

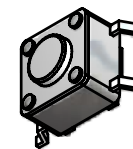

▲ ALL TERMINALS MUST BE
COPLANAR WITHIN 0.10MM
TOTAL

▲ ACTUATOR COLOR:
BLACK

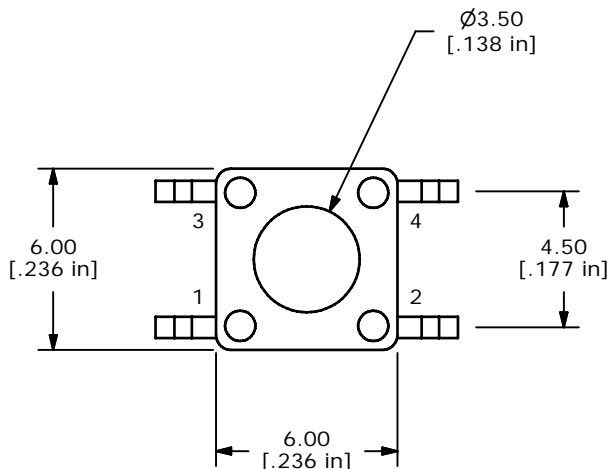
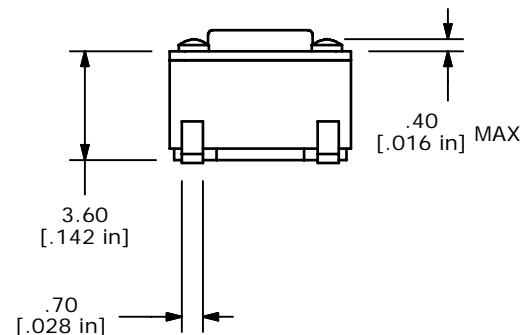
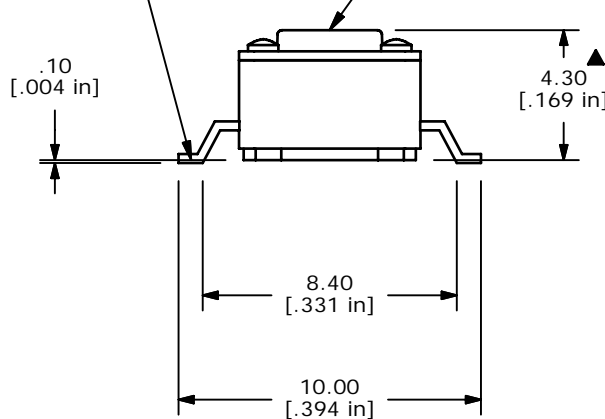

NOTES:

1. ALL DIMENSIONS IN MM
2. GENERAL TOLERANCE: X.X=±0.4
X.XX=±0.25
3. TERM. NOS. FOR REFERENCE ONLY.
4. RATING: 12VDC, 50mA
5. OPERATING FORCE: 100 ± 50 gms
6. TRAVEL: 0.25mm ±0.1
7. CONTACT RESISTANCE: 100 MILLI OHMS MAX. (INITIAL)
8. MECHANICAL/ELECTRICAL LIFE 100,000 CYCLES MIN.
9. SILVER CONTACTS
10. ▲DENOTES CRITICAL PARAMETER
11. 2002/95/EC (ROHS) COMPLIANT.
12. PACKAGING: TAPE ARND REEL, 1000 PIECES PER REEL



TITLE TL3301NF100QG

A	20787	NEW RELEASE	9/28/12	rc
REV	PCR NO	DESCRIPTION	DATE	BY

SCALE	DATE 9/28/2012	DR rc	DWG J100524	REV A
-------	-------------------	----------	----------------	----------

THE INFORMATION CONTAINED IN THIS DOCUMENT IS PROPRIETARY TO E-SWITCH AND IS NOT TO BE COPIED OR TRANSFERRED