

OV12825 12.6-megapixel product brief



Advanced 12.6-Megapixel Mobile Imaging with 1080p/60 HD Video and EIS



available in a lead-free package

The OV12825 is a 12.6-megapixel RAW CMOS image sensor designed specifically for high-performance mobile applications. Offering both DSC-quality photography and full 1080p/60 high-definition (HD) video with electronic image stabilization (EIS) makes the sensor a highly attractive solution for high-end feature and smart phone manufacturers.

With a 1/2.5-inch optical format, the OV12825 utilizes OmniVision's proven 1.4-micron OmniBSI™ backside illumination (BSI) pixel architecture to achieve best-in-class pixel performance and low-light sensitivity of 650 mV/lux-sec. The sensor has a unique binning capability that further increases sensitivity in 1080p HD video mode at 60 frames per second (fps), while still providing additional pixels for EIS. The OV12825 has an active array of 4224 x 3000 BSI pixels operating at 15 fps in full resolution. Additional benefits of OmniBSI technology

include increased quantum efficiency, reduced crosstalk and low photo response non-uniformity, which all contribute towards significant improvement in image quality and camera performance.

Offered with industry standard connectivity including 4-lane MIPI, LVDS and DVP interfaces, the OV12825 supports 10/12-bit RAW RGB and CCIR656 output formats. The sensor offers programmable controls for frame rate, mirror and flip, cropping, and windowing as well as support for horizontal and vertical sub-sampling. All required automatic image processing functions, including exposure control, gain control, white balance, band filter, 50/60 Hz frequency detection and black level calibration are programmable through the SCCB interface.

Find out more at www.ovt.com.

Applications

- Cellular and Mobile Phones
- Digital Video Camcorders (DVC)
- Digital Still Cameras (DSC)

Product Features

- ultra high performance
- automatic image control functions:
 - automatic exposure control (AEC)
 - automatic gain control (AGC)
 - automatic white balance (AWB)
 - automatic band filter (ABF)
 - automatic 50/60 Hz frequency detection
 - automatic black level calibration (ABLC)
- programmable controls for frame rate, mirror and flip, cropping, and windowing
- image quality controls: lens correction and defective pixel canceling
- support for output formats: 10/12-bit RAW RGB data (DVP), 10/12-bit RAW RGB data (MIPI/LVDS), CCIR656
- support for horizontal and vertical subsampling
- support for images sizes: 12.6 Mpixel, EIS1080p, 1080p, EIS720p, 720p, VGA, etc.
- support for binning
- standard serial SCCB interface
- digital video port (DVP) parallel output interface
- LVDS serial output interface
- MIPI serial output interface
- embedded one-time programmable (OTP) memory for part identification, etc.
- on-chip phase lock loop (PLL)
- programmable I/O drive capability
- built-in 1.5 V regulator for core

OV12825

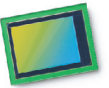

Ordering Information

- OV12825-G04A**
(color, chip probing, 200 μm backgrinding, reconstructed wafer with good die)
- OV12825-A16A**
(color, lead-free, 116-pin CSP3)

Product Specifications

- active array size:** 4224 x 3000
- power supply:**
 - core: 1.5 VDC ±5% (internal regulator optional)
 - analog: 2.6 - 3.0 V (2.8 V typical)
 - I/O: 1.7 - 3.0 V (1.8 V/2.8 V typical)
- power requirements:**
 - active: 230 mW
 - standby: 40 μA
 - power down: 40 μA
- temperature range:**
 - operating: -30°C to 70°C junction temperature
 - stable image: 0°C to 50°C junction temperature
- output formats:** 10/12-bit RGB RAW (DVP), 10/12-bit RGB RAW (MIPI/LVDS)
- lens size:** 1/2.5"
- lens chief ray angle:** 28.2° non-linear
- input clock frequency:** 6 - 27 MHz
- max S/N ratio:** 35 dB
- dynamic range:** 71 dB @ 8x gain
- maximum image transfer rate:**
 - 12.6M (10-bit): 15 fps
 - EIS1080p (10-bit): 60 fps
- sensitivity:** 650 mV/lux-sec
- scan mode:** progressive
- maximum exposure interval:** 3018 x t_{row}
- pixel size:** 1.4 μm x 1.4 μm
- dark current:** 9 mV/s @ 60°C junction temperature
- image area:** 5958.4 μm x 4216.8 μm
- package/die dimensions:**
 - CSP3: 8935 μm x 6975 μm
 - COB: 8950 μm x 6990 μm

Functional Block Diagram

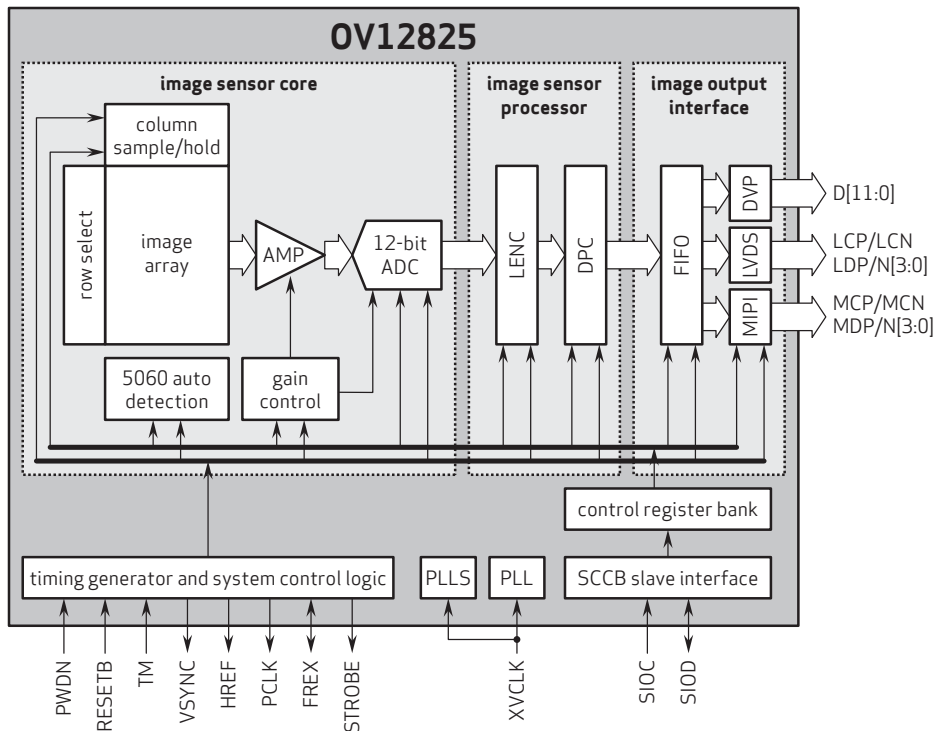

4275 Burton Drive
Santa Clara, CA 95054
USA

Tel: + 1 408 567 3000
Fax: + 1 408 567 3001
www.ovt.com

OmniVision reserves the right to make changes to their products or to discontinue any product or service without further notice. OmniVision and the OmniVision logo are registered trademarks of OmniVision Technologies, Inc. OmniBSI is a trademark of OmniVision Technologies, Inc. All other trademarks are the property of their respective owners.

