



SGM3003

Ultra Low ON-Resistance, Low Voltage, SPDT Analog Switch

GENERAL DESCRIPTION

The SGM3003 is a single, low on-resistance, low voltage, bidirectional, single-pole/double-throw (SPDT) CMOS analog switch designed to operate from a single +1.8V to +5.5V supply. Targeted applications include battery powered equipment that benefit from low R_{ON} (0.5Ω) and fast switching speeds ($t_{ON} = 21ns$, $t_{OFF} = 9ns$).

The on resistance profile is very flat over the full analog signal range. This ensures excellent linearity and low distortion when switching audio signals.

SGM3003 has one normally open switch and one normally closed switch, Each switch conducts equally well in both directions when on.

SGM3003 is available in a Green MSOP-8 package.

APPLICATIONS

Battery powered, Handheld, and Portable Equipment

Cellular/mobile Phones

Laptops, Notebooks, Palmtops

Communication Systems

Sample-and-Hold Circuits

Audio Signal Routing

Audio and Video Switching

Portable Test and Measurement

Medical Equipment

FEATURES

- **Low Voltage Operation: 1.8V to 5.5V**
- **Low On-Resistance: 0.5Ω (TYP)**
- **Low On-Resistance Flatness**
- **-3dB Bandwidth: 30MHz**
- **Fast Switching Times ($V_+ = 5V$)**
 t_{ON} 21ns
 t_{OFF} 9ns
- **Rail-to-Rail Operation**
- **Typical Power Consumption ($< 0.01\mu W$)**
- **TTL/CMOS Compatible**
- **Microsize Package**

PIN CONFIGURATION (TOP VIEW)

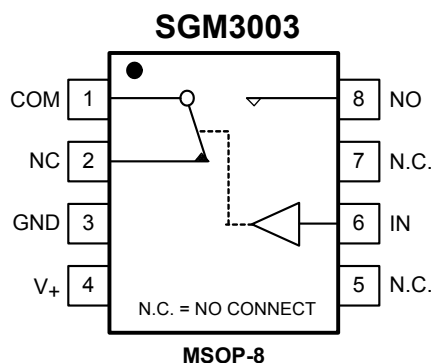

FUNCTION TABLE

LOGIC	NC	NO
0	ON	OFF
1	OFF	ON

PACKAGE/ORDERING INFORMATION

MODEL	PIN-PACKAGE	SPECIFIED TEMPERATURE RANGE	ORDERING NUMBER	PACKAGE MARKING	PACKAGE OPTION
SGM3003	MSOP-8	-40°C to +125°C	SGM3003XMS/TR	SGM3003XMS	Tape and Reel, 3000

ABSOLUTE MAXIMUM RATINGS

V₊ to GND.....-0.3V to 6V
 Analog, Digital voltage range ⁽¹⁾..... -0.3V to (V₊) + 0.3V
 Continuous Current NO, NC, or COM.....±300mA
 Peak Current NO, NC, or COM±500mA
 Operating Temperature Range.....-40°C to +125°C
 Junction Temperature.....150°C
 Storage Temperature Range.....-65°C to +150°C
 Package Thermal Resistance @ T_A = +25°C
 MSOP-8, θ_{JA}.....216°C/W
 Lead Temperature (soldering, 10s).....260°C
 ESD Susceptibility
 HBM.....2000V
 MM.....400V

NOTES:

1. Signals on NC, NO, or COM or IN exceeding V₊ will be clamped by internal diodes. Limit forward diode current to maximum current ratings.
2. Stresses beyond those listed under “Absolute Maximum Ratings” may cause permanent damage to the device. These are stress ratings only, and functional operation of the device at these or any other conditions beyond those indicated in the operational sections of the specifications is not implied. Exposure to absolute maximum rating conditions for extended periods may affect device reliability.

CAUTION

This integrated circuit can be damaged by ESD if you don't pay attention to ESD protection. SGMICRO recommends that all integrated circuits be handled with appropriate precautions. Failure to observe proper handling and installation procedures can cause damage. ESD damage can range from subtle performance degradation to complete device failure. Precision integrated circuits may be more susceptible to damage because very small parametric changes could cause the device not to meet its published specifications.

SGMICRO reserves the right to make any change in circuit design, specification or other related things if necessary without notice at any time. Please contact SGMICRO sales office to get the latest datasheet.

PIN DESCRIPTION

NAME	PIN	FUNCTION
V ₊	4	Power Supply.
GND	3	Ground.
IN	6	Digital Control Pin to Connect the COM Terminal to the NO or NC Terminals.
COM	1	Common Terminal.
NO	8	Normally-Open Terminal.
NC	2	Normally-Closed Terminal.
N.C.	5, 7	No Internal Connection.

NOTE: NO, NC and COM terminals may be an input or output.

ELECTRICAL CHARACTERISTICS(V₊ = +5V ± 10%, GND = 0V, T_A = -40°C to +125°C. Typical values are at T_A = +25°C, unless otherwise noted.)

PARAMETER	SYMBOL	CONDITIONS	SGM3003			
			+25°C	-40°C to +125°C	UNITS	MIN/MAX
ANALOG SWITCH						
Analog Signal Range	V _{NO} , V _{NC} , V _{COM}			0 V ₊	V V	MIN MAX
On-Resistance	R _{ON}	0 ≤ V _{NO} or V _{NC} ≤ V ₊ , I _{COM} = -10mA, Test Circuit 1	0.5 0.9		Ω Ω	TYP MAX
On-Resistance Flatness	R _{FLAT(ON)}	0 ≤ V _{NO} or V _{NC} ≤ V ₊ , I _{COM} = -10mA, Test Circuit 1	0.13 0.2		Ω Ω	TYP MAX
LEAKAGE CURRENTS						
Source OFF Leakage Current	I _{NC(OFF)} , I _{NO(OFF)}	V _{NO} or V _{NC} = 4.5V/1V, V _{COM} = 1V/4.5V, V ₊ = +5.5V, Test Circuit 2	±4 ±10		nA nA	TYP MAX
Channel ON Leakage Current	I _{NC(ON)} , I _{NO(ON)} , I _{COM(ON)}	V _{NO} or V _{NC} = V _{COM} = 1V or 4.5V, V ₊ = +5.5V, Test Circuit 3	±4 ±10		nA nA	TYP MAX
DIGITAL INPUTS						
Input High Voltage	V _{INH}			2.4	V	MIN
Input Low Voltage	V _{INL}			0.8	V	MAX
Input Current	I _{INL} or I _{INH}	V _{IN} = V _{INH} or V _{INL}	±0.01 ±0.1		μA μA	TYP MAX
DYNAMIC CHARACTERISTICS						
Turn-On Time	t _{ON}	V _{NO} or V _{NC} = 3V, R _L = 300Ω, C _L = 35pF, Test Circuit 4	21		ns	TYP
Turn-Off Time	t _{OFF}	V _{NO} or V _{NC} = 3V, R _L = 300Ω, C _L = 35pF, Test Circuit 4	9		ns	TYP
Charge Injection	Q	C _L = 1.0nF, V _G = 0V, R _G = 0Ω, Test Circuit 5	5		pC	TYP
Break-Before-Make Time Delay	t _D	V _{NO1} or V _{NC1} = V _{NO2} or V _{NC2} = 3V, R _L = 300Ω, C _L = 35pF, Test Circuit 6	10		ns	TYP
Off Isolation	O _{ISO}	R _L = 50Ω, C _L = 5pF, Test Circuit 7	f = 100kHz f = 10kHz	-55 -75	dB dB	TYP TYP
Total Harmonic Distortion	THD	f = 20Hz to 20kHz, V _{COM} = 3.5V _{P-P} , R _L = 600Ω, C _L = 50pF	0.065		%	TYP
-3dB Bandwidth	BW	R _L = 50Ω, C _L = 5pF, Test Circuit 8	30		MHz	TYP
Source OFF Capacitance	C _{NC(OFF)} , C _{NO(OFF)}		82		pF	TYP
Channel ON Capacitance	C _{NC(ON)} , C _{NO(ON)} , C _{COM(ON)}		380		pF	TYP
POWER REQUIREMENTS						
Power Supply Current	I ₊	V ₊ = +5.5V, V _{IN} = 0V or 5V	0.001		μA	TYP
				1	μA	MAX

ELECTRICAL CHARACTERISTICS(V₊ = +3V ± 10%, GND = 0V, T_A = -40°C to +125°C. Typical values are at T_A = +25°C, unless otherwise noted.)

PARAMETER	SYMBOL	CONDITIONS	SGM3003			
			+25°C	-40°C to +125°C	UNITS	MIN/MAX
ANALOG SWITCH						
Analog Signal Range	V _{NO} , V _{NC} , V _{COM}			0 V ₊	V V	MIN MAX
On-Resistance	R _{ON}	0 ≤ V _{NO} or V _{NC} ≤ V ₊ , I _{COM} = -10mA, Test Circuit 1	0.6 1.0		Ω Ω	TYP MAX
On-Resistance Flatness	R _{FLAT(ON)}	0 ≤ V _{NO} or V _{NC} ≤ V ₊ , I _{COM} = -10mA, Test Circuit 1	0.18 0.3		Ω Ω	TYP MAX
LEAKAGE CURRENTS						
Source OFF Leakage Current	I _{NC(OFF)} , I _{NO(OFF)}	V _{NO} or V _{NC} = 3V/1V, V _{COM} = 1V/3V, V ₊ = +3.3V, Test Circuit 2	±5 ±11		nA nA	TYP MAX
Channel ON Leakage Current	I _{NC(ON)} , I _{NO(ON)} , I _{COM(ON)}	V _{NO} or V _{NC} = V _{COM} = 1V or 3V, V ₊ = +3.3V, Test Circuit 3	±5 ±11		nA nA	TYP MAX
DIGITAL INPUTS						
Input High Voltage	V _{INH}			2.0	V	MIN
Input Low Voltage	V _{INL}			0.4	V	MAX
Input Current	I _{INL} or I _{INH}	V _{IN} = V _{INH} or V _{INL}	±0.01 ±0.1		μA μA	TYP MAX
DYNAMIC CHARACTERISTICS						
Turn-On Time	t _{ON}	V _{NO} or V _{NC} = 2V, R _L = 300Ω, C _L = 35pF, Test Circuit 4	32		ns	TYP
Turn-Off Time	t _{OFF}	V _{NO} or V _{NC} = 2V, R _L = 300Ω, C _L = 35pF, Test Circuit 4	20		ns	TYP
Charge Injection	Q	C _L = 1.0nF, V _G = 0V, R _G = 0Ω, Test Circuit 5	10		pC	TYP
Break-Before-Make Time Delay	t _D	V _{NO1} or V _{NC1} = V _{NO2} or V _{NC2} = 2V, R _L = 300Ω, C _L = 35pF, Test Circuit 6	12		ns	TYP
Off Isolation	O _{ISO}	R _L = 50Ω, C _L = 5pF, Test Circuit 7	f = 100kHz f = 10kHz	-55 -75	dB dB	TYP TYP
Total Harmonic Distortion	THD	f = 20Hz to 20kHz, V _{COM} = 2V _{P-P} , R _L = 600Ω, C _L = 50pF	0.06		%	TYP
-3dB Bandwidth	BW	R _L = 50Ω, C _L = 5pF, Test Circuit 8	30		MHz	TYP
Source OFF Capacitance	C _{NC(OFF)} , C _{NO(OFF)}		82		pF	TYP
Channel ON Capacitance	C _{NC(ON)} , C _{NO(ON)} , C _{COM(ON)}		380		pF	TYP
POWER REQUIREMENTS						
Power Supply Current	I ₊	V ₊ = +3.3V, V _{IN} = 0V or 3V	0.001		μA	TYP
				1	μA	MAX

TYPICAL PERFORMANCE CHARACTERISTICS

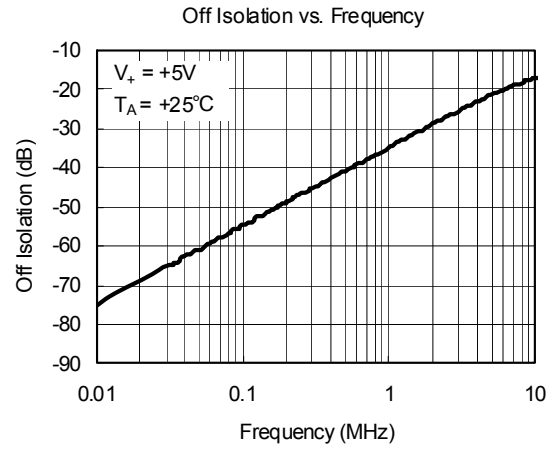
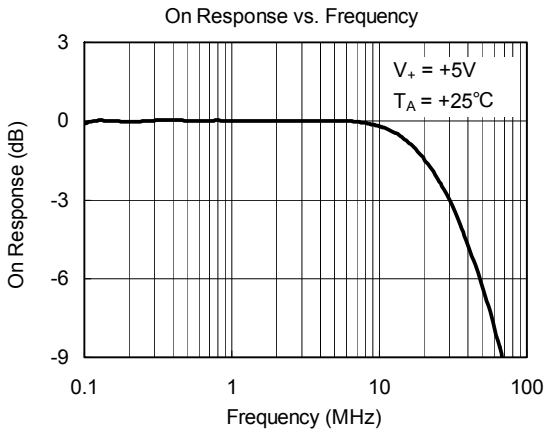

TEST CIRCUITS

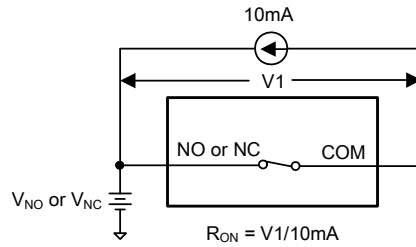

Test Circuit 1. On Resistance

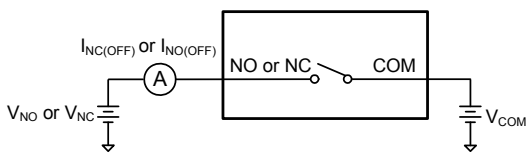

Test Circuit 2. Off Leakage

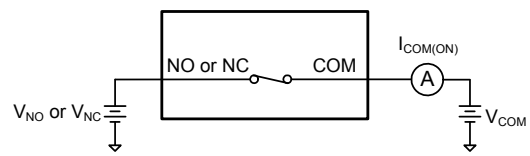

Test Circuit 3. On Leakage

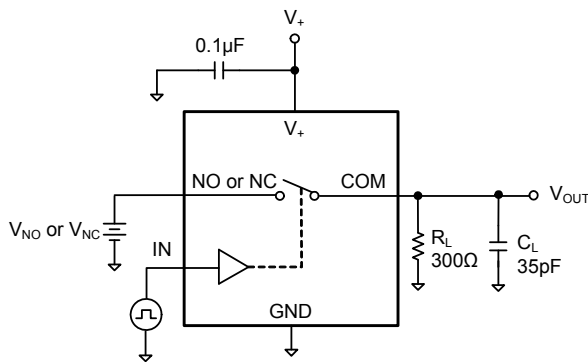

Test Circuit 4. Switching Times

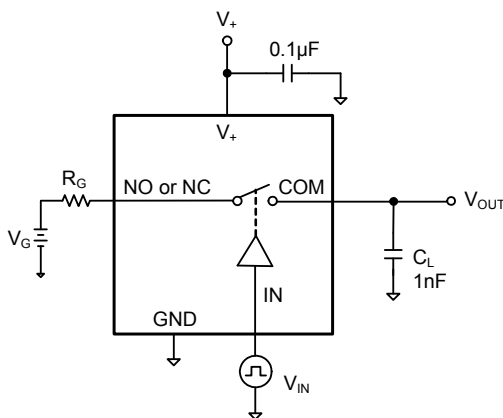
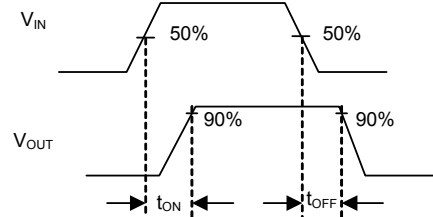

Test Circuit 5. Charge Injection

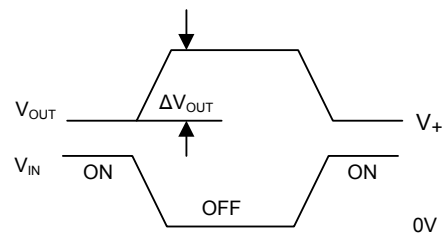

TEST CIRCUITS (Cont.)

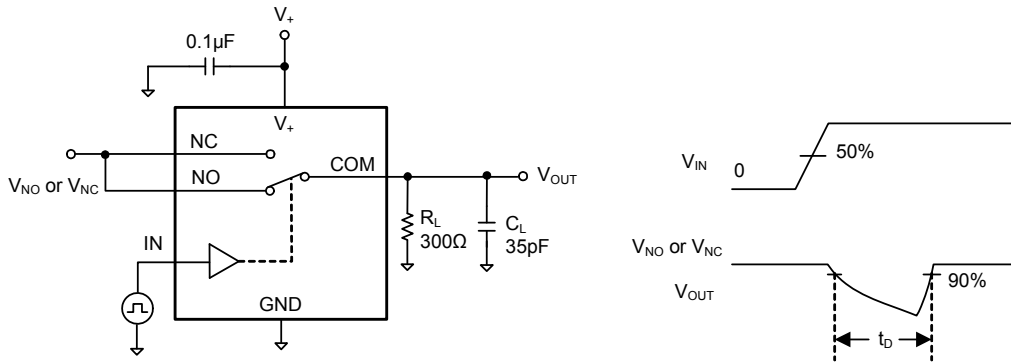

Test Circuit 6. Break-Before-Make Time Delay, t_d

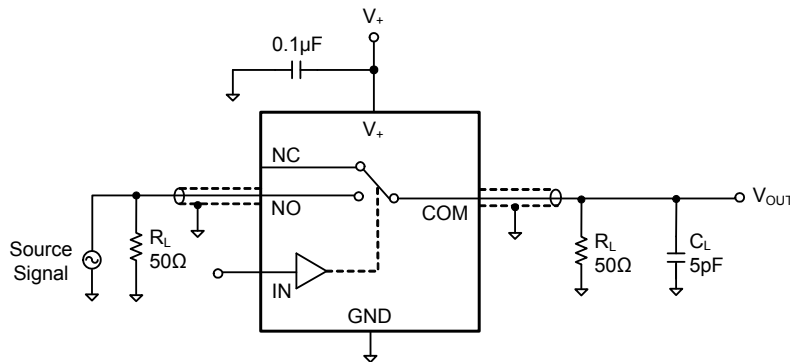

Test Circuit 7. Off Isolation

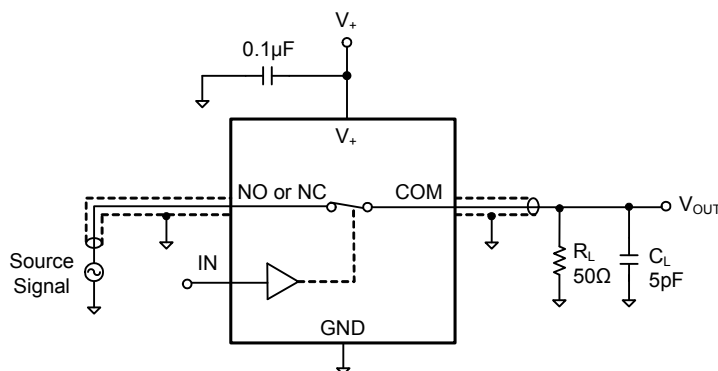

Test Circuit 8. -3dB Bandwidth

PACKAGE OUTLINE DIMENSIONS

MSOP-8

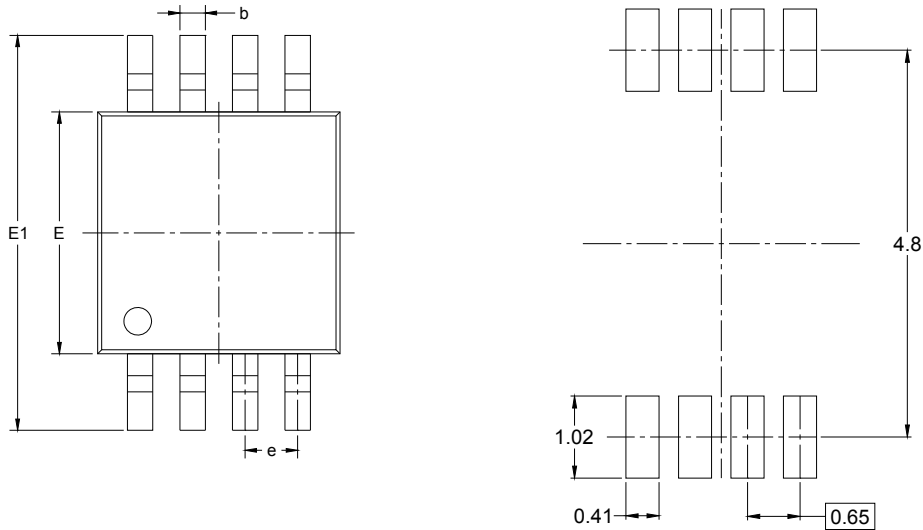

RECOMMENDED LAND PATTERN (Unit: mm)

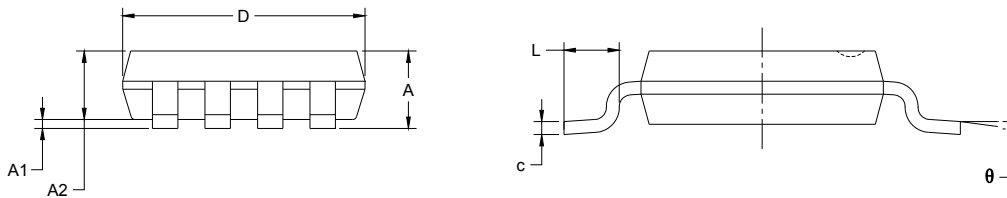

Symbol	Dimensions In Millimeters		Dimensions In Inches	
	MIN	MAX	MIN	MAX
A	0.820	1.100	0.032	0.043
A1	0.020	0.150	0.001	0.006
A2	0.750	0.950	0.030	0.037
b	0.250	0.380	0.010	0.015
c	0.090	0.230	0.004	0.009
D	2.900	3.100	0.114	0.122
E	2.900	3.100	0.114	0.122
E1	4.750	5.050	0.187	0.199
e	0.650 BSC		0.026 BSC	
L	0.400	0.800	0.016	0.031
θ	0°	6°	0°	6°

TAPE AND REEL INFORMATION

REEL DIMENSIONS

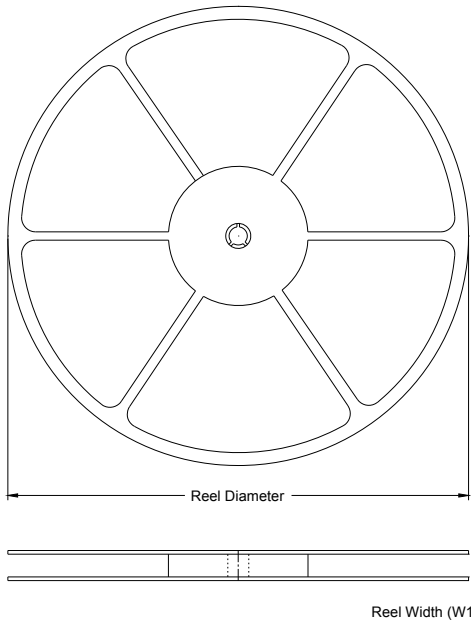

TAPE DIMENSIONS

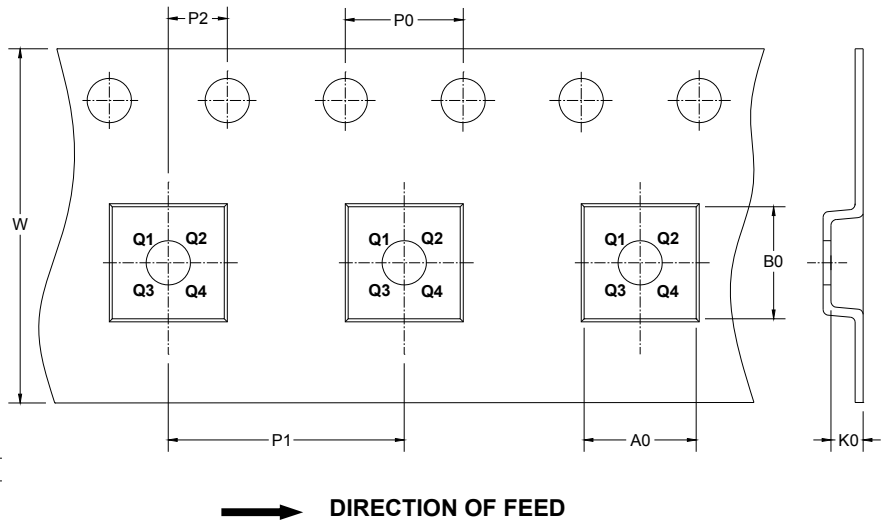

NOTE: The picture is only for reference. Please make the object as the standard.

KEY PARAMETER LIST OF TAPE AND REEL

Package Type	Reel Diameter	Reel Width W1 (mm)	A0 (mm)	B0 (mm)	K0 (mm)	P0 (mm)	P1 (mm)	P2 (mm)	W (mm)	Pin1 Quadrant
MSOP-8	13"	12.4	5.2	3.3	1.5	4.0	8.0	2.0	12.0	Q1

SGM3003

Ultra Low ON-Resistance, Low Voltage, SPDT Analog Switch

CARTON BOX DIMENSIONS

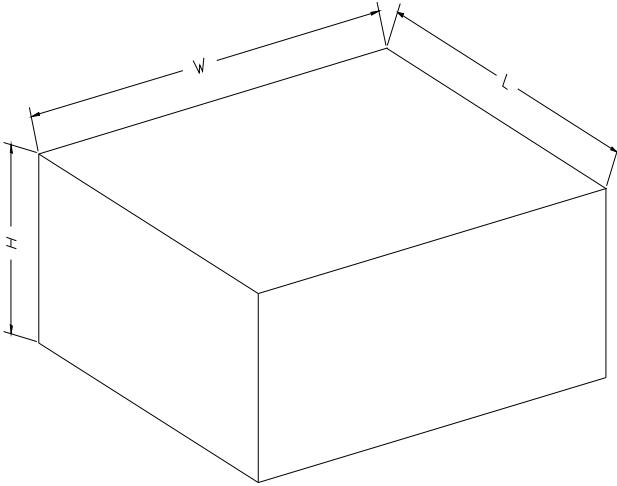

NOTE: The picture is only for reference. Please make the object as the standard.

KEY PARAMETER LIST OF CARTON BOX

Reel Type	Length (mm)	Width (mm)	Height (mm)	Pizza/Carton
13"	386	280	370	5