

DASH NO.	M CODE	MADE FROM
----------	--------	-----------

# GSD

1203-29-9

**REVISIONS**

ISSUE	CHANGES
0	ER 39597 DRK 08/25/06
1	CN 39971 C DRK 06/18/07

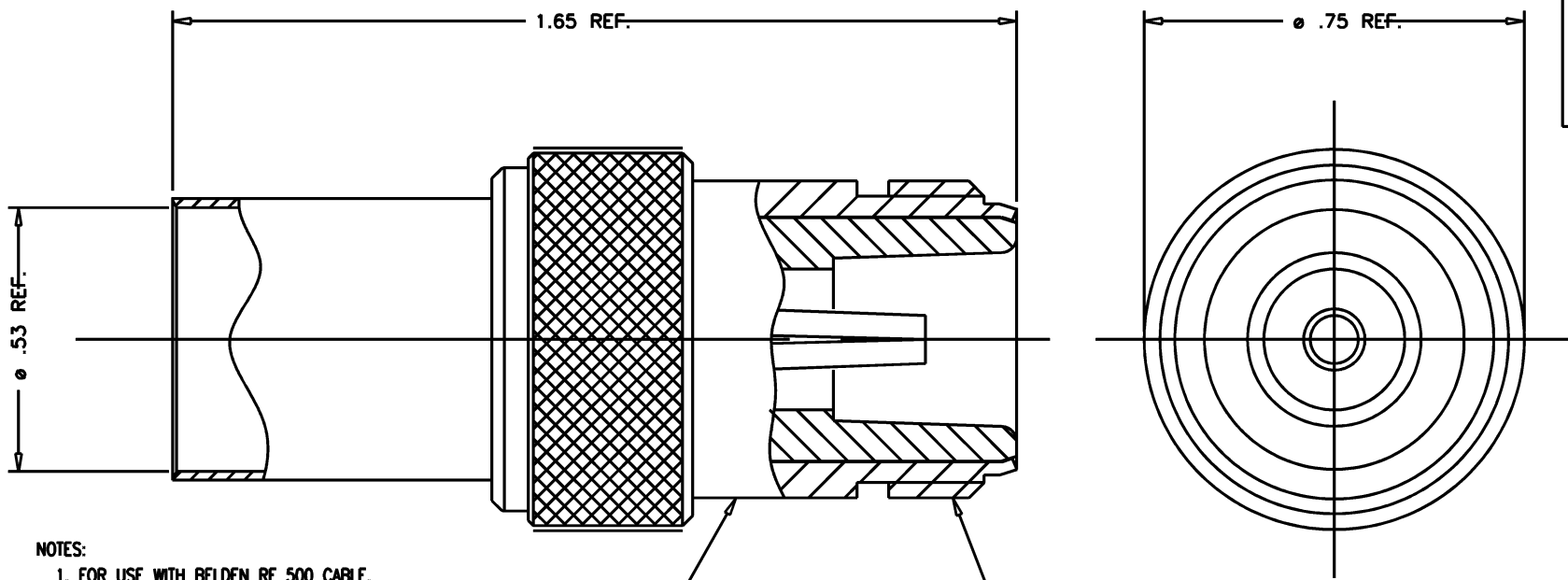

**NOTES:**

1. FOR USE WITH BELDEN RF 500 CABLE.
2. FOR CABLING INSTRUCTIONS SEE 3-800.
3. FOR CRIMPING USE DIE KTH-2279.
4. INTERFACE PER MIL-STD-348, FIG. 304-2.
5. CRIMPING SLEEVE AND CENTER CONTACT TO BE SUPPLIED UNASSEMBLED.
6. MATERIALS:  
 INSULATOR: TEFLON.  
 K-GRIP SLEEVE: COMMERCIAL BRONZE.  
 CENTER CONTACT: BER. COPPER, ASTM-B196.  
 ALL OTHER METAL PARTS: BRASS.
7. FINISHES:  
 CENTER CONTACT: GOLD, ASTM-B488.  
 ALL OTHER METAL PARTS: KINGS TARNISH RESISTANT NICKEL FINISH (TR-5).
8. ELECTRICAL CHARACTERISTICS:  
 NOMINAL IMPEDANCE: 50 OHMS.  
 WORKING VOLTAGE: 1000 VRMS.  
 FREQUENCY RANGE: DC TO 11 GHZ.

STAMP: KINGS 1203-29-9  
YRWK(DATE CODE)

5/8-24UNEF-2A THREAD

SCALE 4:1

APPROX SURFACE AREA

USED ON

REF: EQR 933

JACK, N

DRAWN DRK	DATE 10/05/05
-----------	---------------

DESIGN DRK	DATE 10/05/05
------------	---------------

APPR.	DATE
-------	------

A Winchester Electronics Company

1203-29-9

# GSD