

### Description

The KIT5033C is a photo interrupter high-performance standard type, combines high-output GaAs IRED with high sensitive phototransistor..

### Features

- Snap-in mount
- GAP : 5.0mm
- 3 kinds of mounting plate thicknesses :  
1.0mm, 1.2mm, 1.6mm
- RoHS compliant



### Applications

- Printers.
- Copiers
- ATM
- Ticket vending machines

### Absolute Maximum Ratings (T<sub>a</sub>=25°C, Unless otherwise specified)

Characteristic		Symbol	Ratings	Unit
Input	Power Dissipation	P <sub>D</sub>	75	mW
	Forward Current	I <sub>F</sub>	50	mA
	Reverse Voltage	V <sub>R</sub>	6	V
	Peak Forward Current <sup>*1</sup>	I <sub>FP</sub>	1	A
Output	Collector Current	I <sub>C</sub>	20	mA
	Collector-Emitter Voltage	V <sub>CEO</sub>	35	V
	Emitter-Collector Voltage	V <sub>ECO</sub>	6	V
Operating Temperature <sup>*2</sup>		T <sub>opr</sub>	-30 ~ +95	°C
Storage Temperature <sup>*2</sup>		T <sub>stg</sub>	-40 ~ +100	°C

\*1 : Pulse width (tw) ≤ 100μs, Period (T) = 10msec.

\*2 : No icebond or dew.

The contents of this data sheet are subject to change without advance notice for the purpose of improvement. When using this product, would you please refer to the latest specifications.

## Electrical Characteristics (T<sub>a</sub>=25°C)

Characteristic		Symbol	Test Condition	Min.	Typ.	Max.	Unit
Input	Forward Voltage	V <sub>F</sub>	I <sub>F</sub> =20mA	-	1.2	1.4	V
	Peak Wavelength	λ <sub>p</sub>	I <sub>F</sub> =20mA	-	940	-	nm
	Reverse Current	I <sub>R</sub>	V <sub>R</sub> =5V	-	-	10	uA
Output	Dark Current	I <sub>CEO</sub>	V <sub>CE</sub> =10V, E=0lux	-	1	100	nA
	Peak Wavelength	λ <sub>p</sub>	-	-	880	-	nm
Transfer Characteristics	Collector Current	I <sub>C</sub>	V <sub>CE</sub> =5.0V, I <sub>F</sub> =20mA	0.5	-	15.0	mA
	C-E Saturation Voltage	V <sub>CE(sat)</sub>	I <sub>C</sub> =0.5mA, I <sub>F</sub> =20mA	-	-	0.4	V
Response Time	Rise Time	t <sub>r</sub>	V <sub>CC</sub> =5.0V, I <sub>C</sub> =2mA RL=100Ω	-	3	15	usec
	Fall Time	t <sub>f</sub>		-	4	20	usec

\* Circuit for Measuring Response Time

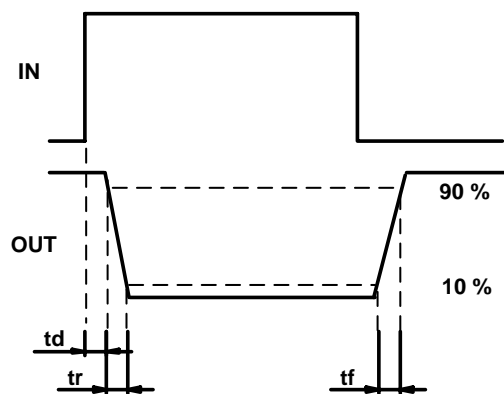
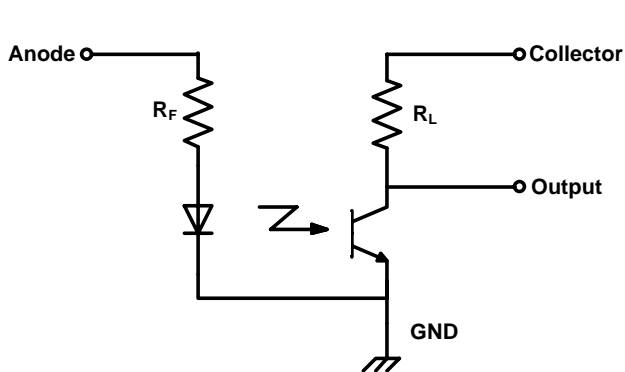

The contents of this data sheet are subject to change without advance notice for the purpose of improvement. When using this product, would you please refer to the latest specifications.

## Characteristics

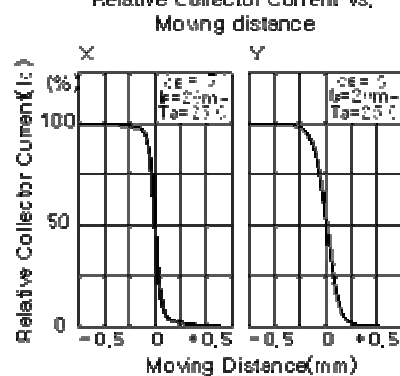
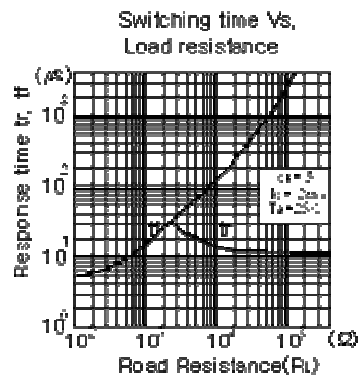
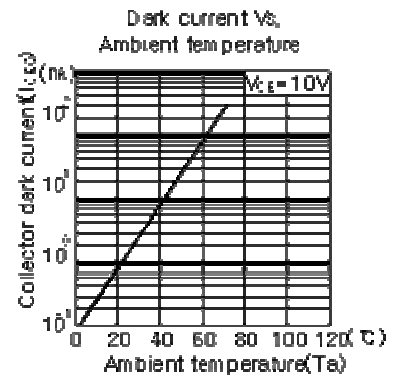
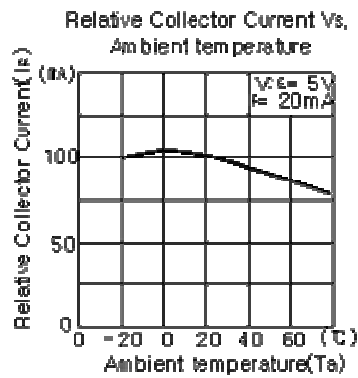
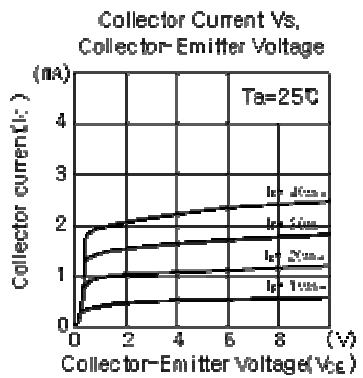
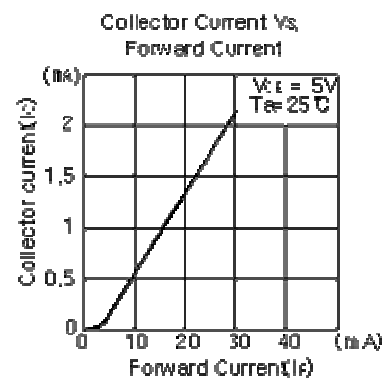
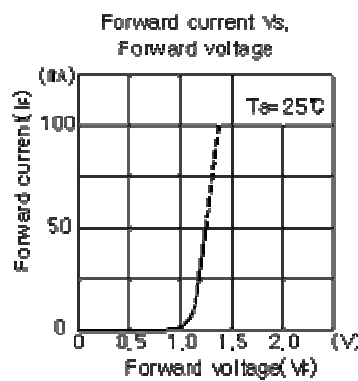
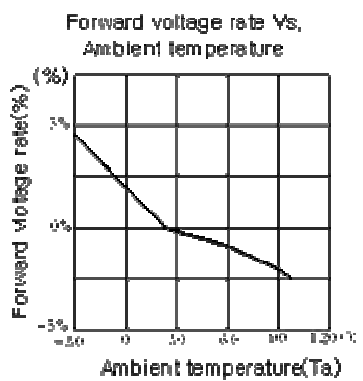
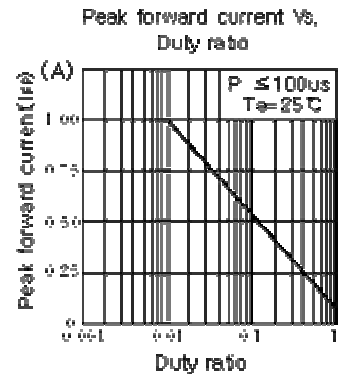
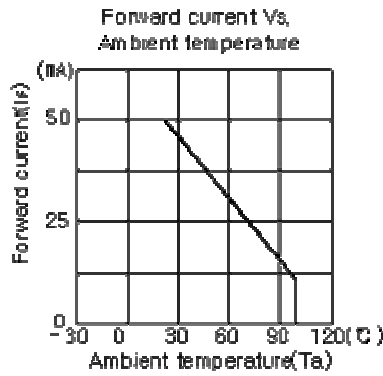
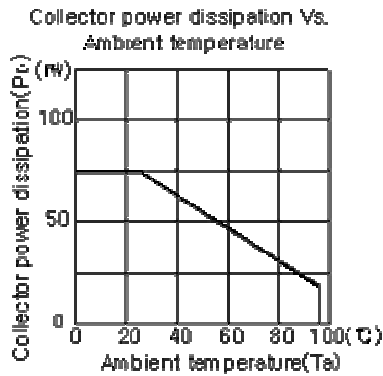

Method of measuring position detection characteristic

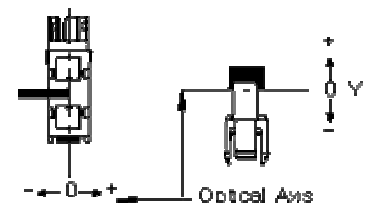

The contents of this data sheet are subject to change without advance notice for the purpose of improvement. When using this product, would you please refer to the latest specifications.

## Package Outline Dimensions

(ALL DIMENSIONS IN MILLIMETERS)

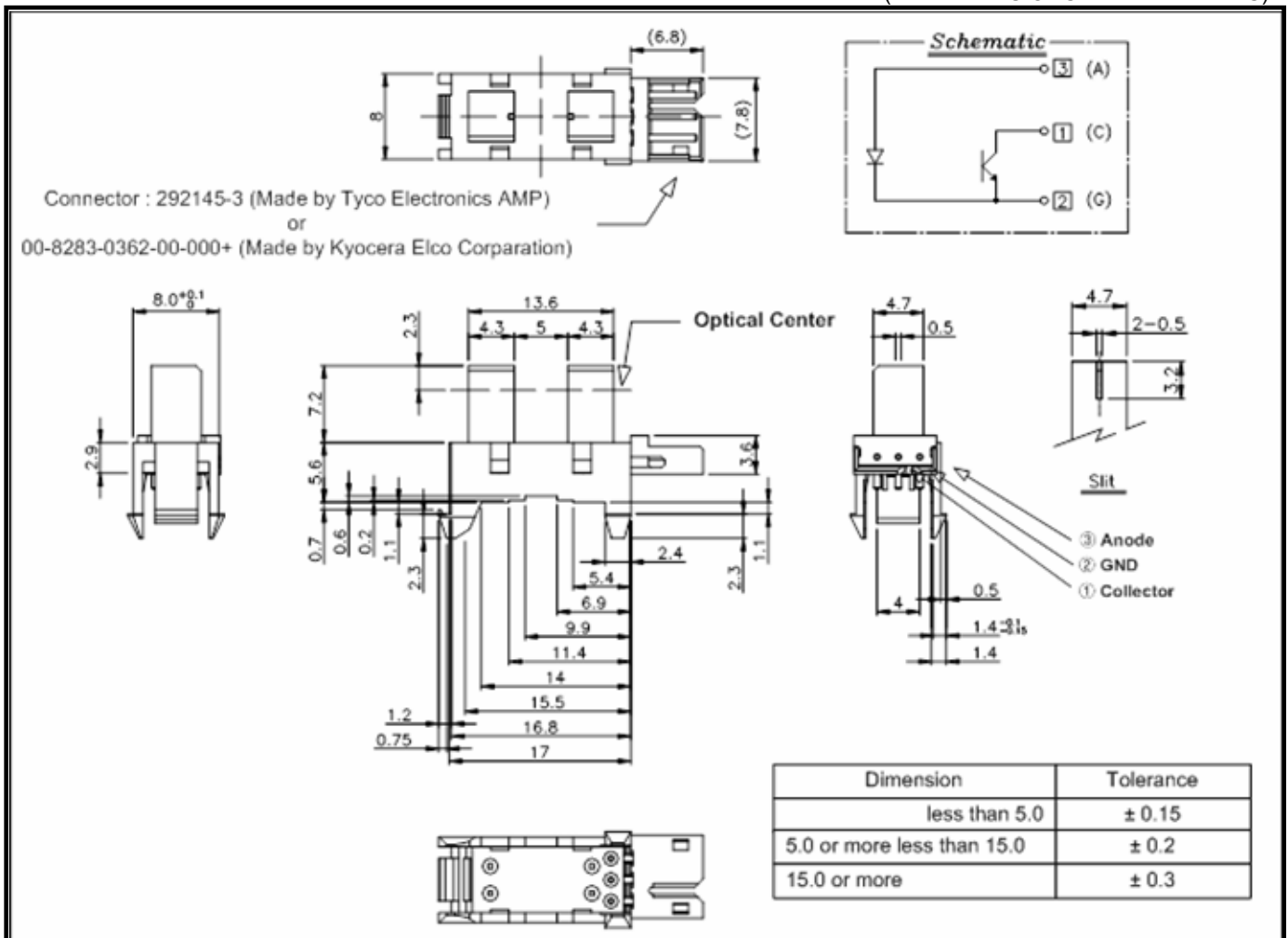

The contents of this data sheet are subject to change without advance notice for the purpose of improvement. When using this product, would you please refer to the latest specifications.