

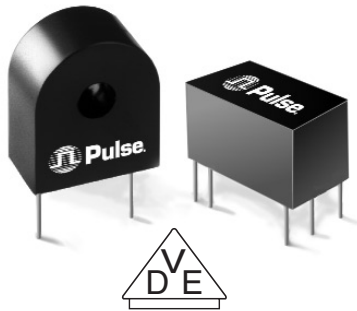



THT CURRENT SENSE TRANSFORMERS & INDUCTORS



-  VDE Approved
-  Designed for switching power supply applications
-  Transformer meets IEC950 insulation requirements
-  Frequency range from 20kHz to 200kHz

Electrical Specifications @ 25°C — Operating Temperature -40°C to 130°C

| Part Number Transformer with 2-1 T Primaries | Schem. Figure | Part Number Transformer with 1T Primary | Schem. Figure | Part Number Inductor without Primary | Schem. Figure | Turns Ns | Secondary Inductance MH (MIN) | Secondary Inductance Test Voltage (15.75 KHz) | RS (Ω MAX) | RT (Ω NOM) | Primary Unipolar Amp μ Sec. Rating (MAX) | Primary Bipolar Amp μ Sec. Rating (MAX) |
|--|---------------|---|---------------|--------------------------------------|---------------|----------|-------------------------------|---|------------|------------|--|---|
| — | 1C | PE-63586 | 1A | PE-51686 | 2A | 50 | 5.0 | 0.5 | 0.7 | 50 | 150 | 300 |
| PE-64487 | 1C | PE-63587 | 1A | PE-51687 | 2A | 100 | 20.0 | 1.0 | 1.40 | 100 | 300 | 600 |
| PE-64488 | 1C | PE-63588 | 1A | PE-51688 | 2A | 200 | 80.0 | 2.0 | 4.50 | 200 | 600 | 1200 |
| PE-64517 | 1D | PE-63617 | 1B | PE-51717 | 2B | 50CT | 5.0 | 0.5 | 0.7 | 50 | 150 | 300 |
| PE-64518 | 1D | PE-63618 | 1B | PE-51718 | 2B | 100CT | 20.0 | 1.0 | 1.40 | 100 | 300 | 600 |
| PE-64519 | 1D | PE-63619 | 1B | PE-51719 | 2B | 200CT | 80.0 | 2.0 | 4.50 | 200 | 600 | 1200 |
| — | — | PE-63691 | 1B | — | — | 300CT | 180.0 | 3.0 | 11.0 | 300 | 900 | 1800 |

NOTES:

- Maximum ratings specified with rated secondary terminating resistance and 1 turn primary.
- Amp-microsecond (AμSec.) rating of primary equals volt microsecond (VμSec.) rating of secondary when secondary is terminated in rated resistance. (Amp—microseconds is equal to the product of a square pulse of current in amps, times the current pulse width in microseconds.
- Maximum operating temperature 105°C (ambient plus rise).
- When terminated with rated terminating resistance, the inductor scale factor is Vout = 1 volt per amp. for center tapped units terminating resistance for each half of winding is listed value divided by two.
- 1 turn primary peak sense current is 20 amps for all parts listed above.

Mechanicals

Schematics

Transformer

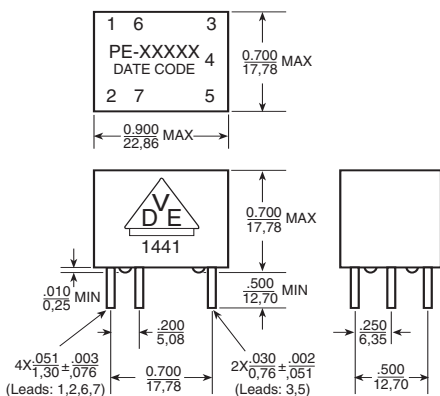

Inductor

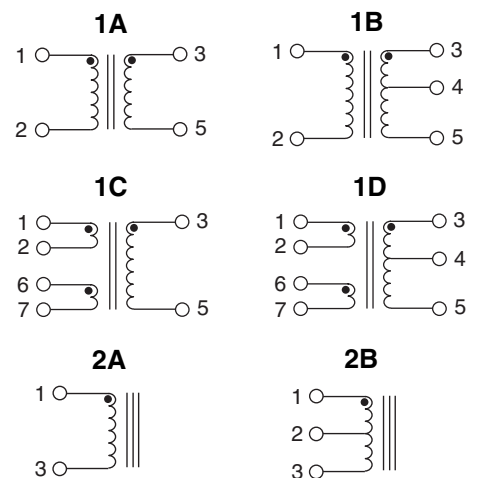
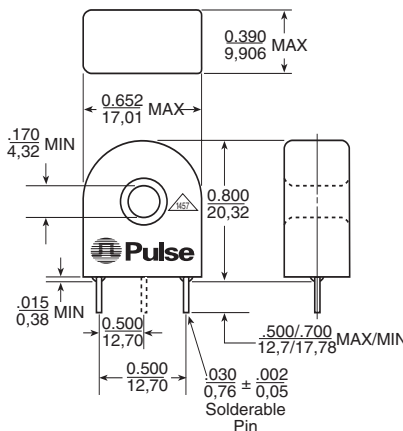

Dimensions: $\frac{\text{Inches}}{\text{mm}}$ Unless otherwise specified, all tolerances are $\pm \frac{.005}{0.13}$

For More Information :

UNITED STATES (Worldwide)

12220 World Trade Drive
San Diego, CA 92128
U.S.A.
<http://www.pulseeng.com>
TEL: 858 674 8100
FAX: 858 674 8262

UNITED KINGDOM (Northern Europe)

1 & 2 Huxley Road
The Surrey Research Park
Guildford, Surrey GU2 5RE
United Kingdom
TEL: 44 1483 401700
FAX: 44 1483 401701

FRANCE (Southern Europe)

Zone Industrielle
F-39270
Orgelet
France
TEL: 33 3 84 35 04 04
FAX: 33 3 84 25 46 41

SINGAPORE (Southern Asia)

150 Kampong Ampat
#07-01/02
KA Centre
Singapore 368324
TEL: 65 6287 8998
FAX: 65 6280 0080

TAIWAN, R.O.C. (Northern Asia)

3F-4, No. 81, Sec. 1
HsinTai Wu Road
Hsi-Chih, Taipei Hsien
Taiwan, R.O.C.
Tel: 886 2 2698 0228
FAX: 886 2 2698 0948

HONG KONG (China/Hong Kong)

9/F, Phase 2, Tai Sang
Shatin Warehouse Centre
6 Wong Chuk Yeung Street
Fotan, Shatin, Hong Kong
TEL: 852 2788 6588
FAX: 852 2776 1055

DISTRIBUTOR

Performance warranty of products offered on this data sheet is limited to the parameters specified. Data is subject to change without notice. Other brand and product names mentioned herein may be trademarks or registered trademarks of their respective owners.