



MPC5645S



416 TEPBGA
27 mm x 27 mm



208 LQFP
28 mm x 28 mm



176 LQFP
24 mm x 24 mm

MPC5645S Microcontroller Data Sheet

- Dual-issue, 32-bit Power Architecture Book E compliant CPU core complex (e200z4d)
 - Memory Management Unit (MMU)
 - 4 KB, 2/4-way instruction cache
- 2 MB on-chip ECC flash memory with:
 - Flash memory controller
 - Prefetch buffers
- 64 KB on-chip ECC SRAM
- 1 MB on-chip non-ECC graphics SRAM with two-port graphics SRAM controller
- Memory Protection Unit (MPU) with up to 16 region descriptors and 32-byte region granularity to provide basic memory access permission and ensure separation between different codes and data
- Interrupt Controller (INTC) with 181 peripheral interrupt sources and eight software interrupts
- Two Frequency-Modulated Phase-Locked Loops (FMPLLs)
 - Primary FMPLL (FMPLL0) provides a system clock up to 125 MHz
 - Auxiliary FMPLL (FMPLL1) is available for use as an alternate, modulated or non-modulated clock source to eMIOS modules, QuadSPI and as alternate clock to the DCU and DCU-Lite for pixel clock generation
- Crossbar switch architecture enables concurrent access of peripherals, flash memory or RAM from multiple bus masters
- 16-channel Enhanced Direct Memory Access controller (eDMA) with multiple transfer request sources using a DMA channel multiplexer
- Boot Assist Module (BAM) with 8 KB dedicated ROM for embedded boot code supports boot options including download of boot code via a serial link (CAN or SCI)
- Two Display Control Units (DCU3 and DCULite) for direct drive of up to two TFT LCD displays up to XGA resolution
- Timing Controller (TCON) and RSDS interface for the DCU3 module
- 2D OpenVG 1.1 and raster graphics accelerator (GFX2D)
- Video Input Unit (VIU2) supporting 8/10-bit ITU656 video input, YUV to RGB conversion, video down-scaling, de-interlacing, contrast adjustment and brightness adjustment.
- DRAM controller supporting DDR1, DDR2, and LPDDR1 DRAMs
- Stepper Motor Controller (SMC)
 - High-current drivers for up to six instrument cluster gauges driven in full dual H-bridge configuration
 - Stepper motor return-to-zero and stall detection module
 - Stepper motor short circuit detection
- Sound Generator Module (SGM)
 - 4-channel mixer
 - Supports PCM wave playback and synthesized tones
 - Optional PWM or I²S outputs
- Two 16-channel Enhanced Modular Input Output System (eMIOS) modules
 - Support a range of 16-bit Input Capture, Output Compare, Pulse Width Modulation and Quadrature Decode functions
- 10-bit Analog-to-Digital Converter (ADC) with a maximum conversion time of 1 μ s
 - Up to 20 internal channels
 - Up to 8 external channels
- Three Deserial Serial Peripheral Interface (DSPI) modules for full-duplex, synchronous, communications with external devices
- QuadSPI serial flash memory controller
 - Supports single, dual and quad IO serial flash memory
 - Interfaces to external, memory-mapped serial flash memories
 - Supports simultaneous addressing of 2 external serial flashes to achieve up to 80 MB/s read bandwidth

Freescale reserves the right to change the detail specifications as may be required to permit improvements in the design of its products.

© Freescale Semiconductor, Inc., 2010-2011. All rights reserved.

Table of Contents

1	Overview	4	4	Electrical characteristics	62
1.1	Device comparison	4	4.1	Introduction	62
1.2	Block diagram	6	4.2	Parameter classification	62
1.3	Feature details	7	4.3	Absolute maximum ratings	63
1.3.1	Low-power operation	7	4.4	Recommended operating conditions	64
1.3.2	e200z4d core	9	4.5	Thermal characteristics	66
1.3.3	Crossbar switch (XBAR)	9	4.5.1	General notes for specifications at maximum junction temperature	68
1.3.4	Enhanced Direct Memory Access (eDMA)	10	4.6	EMI (electromagnetic interference) characteristics	71
1.3.5	Interrupt Controller (INTC)	10	4.7	Power management	71
1.3.6	QuadSPI serial flash memory controller	11	4.7.1	Voltage regulator electrical characteristics	71
1.3.7	System Integration Unit Lite (SIUL)	11	4.7.2	Voltage monitor electrical characteristics	73
1.3.8	On-chip flash memory with ECC	12	4.7.3	Low voltage domain power consumption	73
1.3.9	SRAM	12	4.8	DC electrical specifications	75
1.3.10	On-chip graphics SRAM	12	4.9	RESET electrical characteristics	83
1.3.11	Memory Protection Unit (MPU)	12	4.10	Fast external crystal oscillator (4–16 MHz) electrical characteristics	86
1.3.12	2D Graphics Accelerator (GFX2D)	13	4.11	Slow external crystal oscillator (32 KHz) electrical characteristics	87
1.3.13	Display Control Unit (DCU3)	13	4.12	FMPLL electrical characteristics	88
1.3.14	Display Control Unit Lite (DCULite)	14	4.13	Fast internal RC oscillator (16 MHz) electrical characteristics	89
1.3.15	Timing Controller (TCON) and RSDS interface	14	4.14	Slow internal RC oscillator (128 kHz) electrical characteristics	89
1.3.16	RLE decoder	15	4.15	Flash memory electrical characteristics	90
1.3.17	DRAM controller	15	4.16	ADC parameters	90
1.3.18	Video Input Unit (VIU2)	16	4.16.1	Input Impedance and ADC Accuracy	91
1.3.19	Boot Assist Module (BAM)	16	4.16.2	ADC electrical characteristics	96
1.3.20	Enhanced Modular Input/Output System (eMIOS)	16	4.17	AC specifications	97
1.3.21	Analog-to-Digital Converter (ADC)	17	4.18	AC timing	102
1.3.22	Deserial Serial Peripheral Interface (DSPI)	17	4.18.1	IEEE 1149.1 interface timing	102
1.3.23	FlexCAN	18	4.18.2	Nexus debug interface	105
1.3.24	Serial communication interface module (LINFlex)	18	4.18.3	Interface to TFT LCD Panels (DCU3 and DCULite)	106
1.3.25	Inter-Integrated Circuit (I2C) controller modules	19	4.18.4	RSDS interface to TFT LCD panels	110
1.3.26	System clocks and clock generation modules	19	4.18.5	DRAM Interface	112
1.3.27	Periodic Interrupt Timer (PIT)	20	4.18.6	Video Input Unit timing	116
1.3.28	Real Time Counter (RTC)	20	4.18.7	External Interrupt (IRQ) and Non-Maskable Interrupt (NMI) Timing	117
1.3.29	System Timer Module (STM)	21	4.18.8	eMIOS timing	117
1.3.30	Software Watchdog Timer (SWT)	21	4.18.9	FlexCAN timing	118
1.3.31	Stepper Motor Controller (SMC)	21	4.18.10	Deserial Serial Peripheral Interface (DSPI)	118
2	Pinout and signal descriptions	24	4.18.11	I ² C timing	124
2.1	176 LQFP package pinout	24	4.18.12	QuadSPI timing	125
2.2	208 LQFP package pinout	25	4.18.13	TCON/RSDS timing	127
2.3	416 TEPBGA package pinout	25	5	Package mechanical data	128
2.4	Signal description	27	5.1	176 LQFP	129
2.4.1	Pad configuration during reset phases	27	5.2	208 LQFP	131
2.4.2	Voltage supply pins	27	5.3	416 TEPBGA	135
2.4.3	System pins	29	6	Ordering information	137
2.4.4	Nexus pins	30	7	Revision history	138
2.4.5	DRAM interface	31			
2.4.6	VIU muxing	34			
2.4.7	SGM muxing	35			
2.4.8	RSDS special function muxing	35			
2.4.9	Functional ports	36			
3	System design information	61			
3.1	Power-up sequencing	61			

- RLE decoder supporting memory to memory decoding of RLE data in conjunction with eDMA
- Four local interconnect network (LINFlex) controller modules
 - Capable of autonomous message handling (master), autonomous header handling (slave mode), and UART support
 - Compliant with LIN protocol rev 2.1
- Three controller-area network (FlexCAN) modules
 - Compliant with the CAN protocol version 2.0 C
 - 64 configurable buffers
 - Programmable bit rate of up to 1 Mb/s
- Four Inter-Integrated Circuit (I²C) internal bus controllers with master/slave bus interface
- Low-power loop controlled pierce crystal oscillator supporting 4–16MHz external crystal or resonator
- Real Time Counter (RTC) with clock source from internal 128 kHz or 16 MHz oscillator supporting autonomous wake-up with 1 ms resolution with maximum timeout of 2 seconds
 - Support for real time counter (RTC) with clock source from external 32 KHz crystal oscillator, supporting wake-up with 1 s resolution and maximum timeout of one hour
 - RTC optionally clocked by fast 4–16 MHz external oscillator
- System timers:
 - Four-channel 32-bit System Timer Module (STM)
 - Eight-channel 32-bit Periodic Interrupt Timer (PIT) module (including ADC trigger)
 - Software Watchdog Timer (SWT)
- System Integration Unit Lite (SIUL) module to manage external interrupts, GPIO and pad control
- System Status and Configuration Module (SSCM)
 - Provides information for identification of the device, last boot mode, or debug status
 - Provides an entry point for the censorship password mechanism
- Clock Generation Module (MC_CGM) to generate system clock sources and provide a unified register interface, enabling access to all clock sources
- Clock Monitor Unit (CMU)
 - Monitors the integrity of the fast (4–16 MHz) external crystal oscillator and the primary FMPLL (FMPLL0)
 - Acts as a frequency meter, measuring the frequency of one clock source and comparing it to a reference clock
- Mode Entry Module (MC_ME)
 - Controls the device power mode, i.e., RUN, HALT, STOP, or STANDBY
 - Controls mode transition sequences
 - Manages the power control, voltage regulator, clock generation and clock management modules
- Power Control Unit (MC_PCU) to implement standby mode entry/exit and control connections to power domains
- Reset Generation Module (MC_RGM) to manage reset assertion and release to the device at initial power-up
- Nexus Development Interface (NDI) per IEEE-ISTO 5001-2008 Class 3 standard with additional Class 4 features:
 - Watchpoint Triggering
 - Processor Overrun Control
- Device/board boundary-scan testing supported per Joint Test Action Group (JTAG) of IEEE (IEEE 1149.1)
- On-chip voltage regulator controller for regulating the 3.3–5 V supply voltage down to 1.2 V for core logic (requires external ballast transistor)
- Package:¹
 - 176 LQFP, 0.5 mm pitch, 24 mm × 24 mm outline
 - 208 LQFP, 0.5 mm pitch, 28 mm × 28 mm outline
 - 416 TEPBGA, 1mm ball pitch, 27 mm × 27 mm outline

1. See the device comparison table for package offerings for each device in the family.

1 Overview

The MPC5645S represents a new generation of 32-bit microcontrollers targeting single-chip automotive instrument cluster applications. MPC5645S devices are part of the MPC56xxS family of Power Architecture®-based devices. This family has been designed with an emphasis on providing cost-effective and high quality graphics capabilities in order to satisfy the increasing market demand for color Thin Film Transistor (TFT) displays within the vehicle cockpit. Traditional cluster functions, such as gauge drive, real time counter, and sound generation are also integrated on each device.

Devices in the MPC56xxS family contain between 256 KB and 2 MB internal flash memory. The family allows for easy expansion and covers a broad range of cluster applications from low to high-end enabling users to design a complete platform around one common architecture. Serial flash memory and DRAM interfaces are provided to allow even greater system flexibility.

The MPC5645S is designed to reduce development and production costs of TFT-based instrument cluster displays by providing a single-chip solution with the processing and storage capacity to host and execute real-time application software and drive TFT displays directly.

The MPC5645S features a 2D OpenVG graphics accelerator, Video Input Unit (VIU2) and two on-chip display control units (DCU3 and DCULite) designed to drive two color TFT displays simultaneously. The MPC5645S includes an enhanced QuadSPI Serial Flash Controller and an optional DRAM controller allowing graphics RAM expansion externally.

The MPC5645S is compatible with the existing development infrastructure of current Power Architecture devices and are supported with software drivers, operating systems and configuration code to assist with application development.

1.1 Device comparison

Table 1. MPC5645S device comparison

Feature	MPC5645S		
Package	176 LQFP	208 LQFP	416 TEPBGA
CPU	e200z4d 4 KB Instruction-Cache 16-entry Memory Management Unit (MMU) Floating Point Unit (FPU) Signal Processing Extension (SPE)		
Execution speed	Static–125 MHz		
Flash memory (ECC)	2 MB		
RAM (ECC)	64 KB		
On-chip graphics RAM (no ECC)	1 MB		
MPU	16 entry		
eDMA	16 channels		
DRAM controller	No		Yes
OpenVG Graphics Accelerator (GFX2D)	Yes (OpenVG 1.1)		
Display Control Unit (DCU3)	Yes		
Display Control Unit Lite (DCULite)	No	Yes	
Timing Controller (TCON) and RSDS interface	No	Yes	
Video Input Unit (VIU2)	Yes		

Table 1. MPC5645S device comparison (continued)

Feature	MPC5645S		
	176 LQFP	208 LQFP	416 TEPBGA
Package	176 LQFP	208 LQFP	416 TEPBGA
QuadSPI serial flash interface	Yes		
Stepper Motor Controller (SMC)	4 motors	6 motors	
Stepper Stall Detect (SSD)	Yes		
Sound Generator Module (SGM)	Yes		
32 kHz external crystal oscillator	Yes		
Real Time Counter and Autonomous Periodic Interrupt (RTC/API)	Yes		
Periodic interrupt timer (PIT)	8 ch, 32-bit		
Software Watchdog Timer (SWT)	Yes		
System Timer Module (STM)	4 ch, 32-bit		
Timed I/O ¹	20 ch, 16-bit: IC / OC / OPWM 8 ch, 16-bit: IC / OC 4 ch, 16-bit: IC / OC / OPWM / QDEC		
Analog-to-Digital Converter (ADC) ²	16 channels, 10-bit	20 channels, 10-bit	
CAN (64 mailboxes)	3 × FlexCAN		
CAN sampler	Yes		
Serial communication interface	3 × LINFlex	4 × LINFlex	
SPI	2 × DSPI	3 × DSPI	
I ² C	4		
GPIO	128	150	177 ³
Debug	Nexus Class 3 (4×MDO) ⁴		Nexus Class 3 (12×MDO)

¹ IC-Input Capture, OC-Output Compare, OPWM-Output Pulse Width Modulation, QDEC- Quadrature Decode Mode

² Support for external multiplexer enabling up to 8 channels

³ The 416-pin GPIO count does not include the DRAM interface, which is dedicated to DRAM only.

⁴ Nexus pins are multiplexed with other functional pins on 176 LQFP and 208 LQFP package options.

1.2 Block diagram

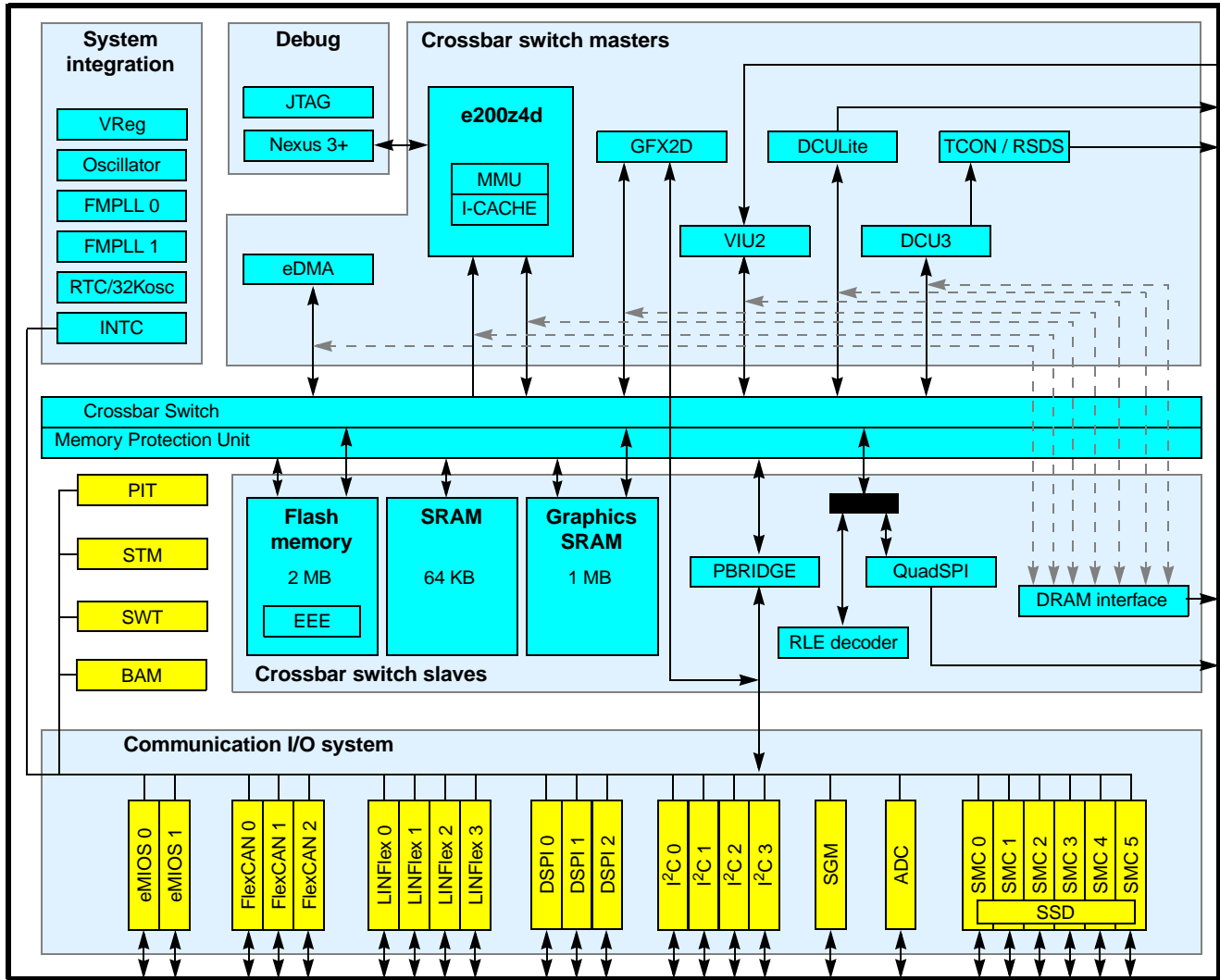

- | | | | |
|----------------|--|----------------|---|
| ADC | – Analog-to-Digital Converter | PBRIDGE | – Peripheral Bridge |
| BAM | – Boot Assist Module | PIT | – Periodic Interrupt Timer |
| eDMA | – Enhanced Direct Memory Access Controller | RLE | – Run Length Encoding |
| DCU3 | – Display Control Unit | RSDS | – Reduced-Swing Differential Signal interface |
| DCULite | – Display Control Unit Lite | RTC | – Real Time Clock |
| DSPI | – Serial Peripherals Interface | SGM | – Sound Generator Module |
| eMIOS | – Enhanced Modular Input/Output System | SMC | – Stepper Motor Controller |
| FlexCAN | – Controller Area Network Controller | SSD | – Stepper Stall Detect |
| FMPLL | – Frequency-Modulated Phase-Locked Loop | STM | – System Timer Module |
| GFX2D | – OpenVG Graphics Accelerator | SWT | – Software Watchdog Timer |
| INTC | – Interrupt Controller | TCON | – Timing Controller |
| JTAG | – Joint Test Action Group interface | VIU2 | – Video Input Unit |
| MMU | – Memory Management Unit | VReg | – Voltage regulator |
| QuadSPI | – Quad IO serial flash interface | | |

Figure 1. MPC5645S block diagram

1.3 Feature details

1.3.1 Low-power operation

The MPC5645S is designed for optimized low-power operation and dynamic power management of the CPU and peripherals. Power management features include software-controlled clock gating of peripherals and multiple power domains to minimize leakage in low-power modes.

There are three low-power modes:

- STANDBY
- STOP
- HALT

and five dynamic power modes — RUN[0..3] and DRUN. All low-power modes use clock gating to halt the clock for all or part of the device.

STANDBY mode turns off the power to the majority of the chip to offer the lowest power consumption mode.

The device can be awakened from STANDBY mode via from any of up to 23 I/O pins, a reset or from a periodic wake-up using a low power oscillator. If required, it is possible to enable the internal 16 MHz oscillator, the external 4–16 MHz oscillator, and the external 32 KHz oscillator.

In STANDBY mode the contents of the CPU, on-chip peripheral registers, and potentially some of the volatile memory are lost. The two possible configurations in STANDBY mode are:

- The device retains 64 KB of the on-chip SRAM, but the content of the graphics SRAM is lost.
- The device retains 8 KB of the on-chip SRAM, but the content of the graphics SRAM is lost.

STOP mode maintains power to the entire device allowing the retention of all on-chip registers and memory, and providing a faster recovery low power mode than the lowest-power STANDBY mode. There is no need to reconfigure the device before executing code. The clocks to the CPU and peripherals are halted and can be optionally stopped to the oscillator or PLL at the expense of a slower start-up time.

STOP is entered from RUN mode only. Wake-up from STOP mode is triggered by an external event or by the internal periodic wake-up, if enabled.

RUN modes are the main operating modes where the entire device can be powered and clocked and from which most processing activity is done. Four dynamic RUN modes are supported—RUN0 - RUN3. The ability to configure and select different RUN modes enables different clocks and power configurations to be supported with respect to each other and to allow switching between different operating conditions. The necessary peripherals, clock sources, clock speed, and system clock prescalers can be independently configured for each of the four RUN modes of the device.

HALT mode is a reduced activity, low power mode intended for moderate periods of lower processing activity. In this mode the CPU system clocks are stopped but user-selected peripheral tasks can continue to run. It can be configured to provide more efficient power management features (switch-off PLL, flash memory, main regulator, etc.) at the cost of longer wake up latency. The system returns to RUN mode as soon as an event or interrupt is pending.

[Table 2](#) summarizes the operating modes of the MPC5645S.

Table 2. Operating mode summary

Operating mode	SoC features					Clock sources						Periodic Wake-up	Wake-up input	VREG mode	Wake-up time ¹							
	CPU GFX accelerator DRAM controller	Peripherals	Flash	SRAM	Graphics RAM	Primary PLL	Auxiliary PLL	16MHz IRC	4-16MHz OSC	128KHz IRC	32KHz X OSC				VREG start-up	IRC Wake-up	Flash Recovery	OSC Stabilization	PLL Lock	S/W Reconfig	Mode switch over	
RUN	On	OP	OP	OP ²	On	OP	OP	On	OP	On	OP	—	—	FP	—	—	—	—	—	—	—	—
HALT	CG	OP	OP	OP ²	On	OP	OP	On	OP	On	OP	OP	OP	FP	—	—	—	—	—	—	—	30 μs ³
STOP	CG	CG	CG	OP ²	CG	CG	CG	OP	OP	On	OP	OP	OP	LP	350 μs	4 μs	20 μs	1 ms	200 μs	—	—	30 μs ³
STANDBY	Off	Off	Off	64K ⁴	Off	Off	Off	OP	OP	On	OP	OP	OP	LP	350 μs	8 μs	100 μs	1 ms	200 μs	Var	—	28 μs
	Off	Off	Off	8K ⁵	Off	Off	Off	OP	OP	On	OP	OP	OP	LP	200 μs	8 μs	100 μs	1 ms	200 μs	Var	—	28 μs
POR															500 μs	8 μs	100 μs	1 ms	200 μs			BAM ⁶

Table key:

- On — Powered and clocked
- OP — Optionally configurable to be enabled or disabled (clock gated)
- CG — Clock Gated, Powered but clock stopped
- Off — Powered off and clock gated
- FP — VREG Full Performance mode
- LP — VREG Low Power mode, reduced output capability of VREG but lower power consumption
- Var — Variable duration, based on the required reconfiguration and execution clock speed
- BAM — Boot Assist Module Software and Hardware used for device start-up and configuration

¹ A high level summary of some key durations that need to be considered when recovering from low power modes. This does not account for all durations at wake up. Other delays will be necessary to consider including, but not limited to the external supply start-up time.

IRC Wake-up time must not be added to the overall wake-up time as it starts in parallel with the VREG.

All other wake-up times must be added to determine the total start-up time.

² Either 64 KB or 8 KB available.

³ Flash configured in disabled mode.

⁴ 64 KB of the RAM contents is retained, but not accessible in STANDBY mode.

⁵ 8 KB of the RAM contents is retained, but not accessible in STANDBY mode.

⁶ Dependent on boot option after reset.

Additional notes on low power operation:

- Fast wake-up using the on-chip 16 MHz internal RC oscillator allows rapid execution from RAM on exit from low power modes
- The 16 MHz internal RC oscillator supports low speed code execution and clocking of peripherals when it is selected as the system clock and can also be used as the PLL input clock source to provide fast start-up without the external oscillator delay
- The device includes an internal voltage regulator that includes the following features:
 - Regulates input to generate all internal supplies
 - Manages power gating
 - External ballast transistor for high power regulator

- Low-Power and Ultra-Low-Power regulators support operation when in STOP and STANDBY modes, respectively, to minimize power consumption
- Startup on-chip regulators in <math><350\mu\text{s}</math> for rapid exit of STOP and STANDBY modes
- Low voltage detection on main supply and 1.2 V regulated supplies

1.3.2 e200z4d core

The e200z4d Power Architecture[®] core provides the following features:

- Dual issue, 32-bit *Power Architecture Book E* compliant CPU
- Implements the VLE APU for reduced code footprint
- In-order execution and retirement
- Precise exception handling
- Branch processing unit
 - Dedicated branch address calculation adder
 - Branch target prefetching using 8-entry BTB
- Supports independent instruction and data accesses to different memory subsystems, such as SRAM and Flash memory via independent Instruction and Data BIUs.
- Load/store unit
 - 2 cycle load latency
 - Fully pipelined
 - Big and Little endian support
 - Misaligned access support
- 64-bit General Purpose Register file
- Dual AHB 2.v6 64-bit System buses
- Memory Management Unit (MMU) with 16-entry fully-associative TLB and multiple page size support
- 4 KB, 2/4-Way Set Associative Instruction Cache
- Signal Processing Extension (SPE1.1) APU supporting SIMD fixed-point operations using the 64-bit General Purpose Register file
- Embedded Floating-Point (EFP2) APU supporting scalar and vector SIMD single-precision floating-point operations, using the 64-bit General Purpose Register file
- Nexus Class 3 real-time Development Unit
- Dynamic power management of execution units, cache and MMU

1.3.3 Crossbar switch (XBAR)

The XBAR multi-port crossbar switch supports simultaneous connections between seven master ports and eight slave ports. The crossbar supports a 32-bit address bus width and a 64-bit data bus width.

The crossbar allows concurrent transactions to occur from any master port to any slave port but one of those transfers must be an instruction fetch from internal flash. If a slave port is simultaneously requested by more than one master port, arbitration logic selects the higher priority master and grants it ownership of the slave port. All other masters requesting that slave port are stalled until the higher priority master completes its transactions. Requesting masters having equal priority are granted access to a slave port in round-robin fashion, based upon the ID of the last master to be granted access.

The crossbar provides the following features:

- Seven master ports:
 - e200z4d core instruction port
 - e200z4d core complex load/store data port

Overview

- eDMA controller
- DCU
- DCULite
- VIU
- 2D Graphics Accelerator (GFX2D)
- Seven slave ports:
 - Platform Flash Controller (2 Ports)
 - Platform SRAM Controller
 - Graphics SRAM Controller (2 Ports)
 - QuadSPI serial flash Controller and RLE Decoder
 - Peripheral Bridge
- 32-bit internal address bus, 64-bit internal data bus
- Programmable Arbitration Priority
 - Requesting masters can be treated with equal priority and will be granted access to a slave port in round-robin fashion, based upon the ID of the last master to be granted access, or a priority order can be assigned by software at application run time
- Temporary dynamic priority elevation of masters

1.3.4 Enhanced Direct Memory Access (eDMA)

The eDMA module is a controller capable of performing complex data movements via 16 programmable channels, with minimal intervention from the host processor. The hardware micro architecture includes a DMA engine which performs source and destination address calculations, and the actual data movement operations, along with an SRAM-based memory containing the transfer control descriptors (TCD) for the channels. This implementation is utilized to minimize the overall block size. The eDMA module provides the following features:

- 16 channels support independent 8-, 16-, or 32-bit single value or block transfers
- Supports variable sized queues and circular queues
- Source and destination address registers are independently configured to post-increment or remain constant
- Each transfer is initiated by a peripheral, CPU, periodic timer interrupt or eDMA channel request
- Each DMA channel can optionally send an interrupt request to the CPU on completion of a single value or block transfer
- DMA transfers possible between system memories, QuadSPI, RLE Decoder, DSPIs, I²C, ADC, eMIOS, and General Purpose I/Os (GPIOs)
- Programmable DMA Channel Mux allows assignment of any DMA source to any available DMA channel with up to a total of 64 potential request sources

1.3.5 Interrupt Controller (INTC)

The INTC (interrupt controller) provides priority-based preemptive scheduling of interrupt requests, suitable for statically scheduled hard real-time systems.

For high priority interrupt requests, the time from the assertion of the interrupt request from the peripheral to when the processor is executing the interrupt service routine (ISR) has been minimized. The INTC provides a unique vector for each interrupt request source for quick determination of which ISR needs to be executed. It also provides an ample number of priorities so that lower priority ISRs do not delay the execution of higher priority ISRs. To allow the appropriate priorities for each source of interrupt request, the priority of each interrupt request is software configurable.

When multiple tasks share a resource, coherent accesses to that resource need to be supported. The INTC supports the priority ceiling protocol for coherent accesses. By providing a modifiable priority mask, the priority can be raised temporarily so that all tasks which share the resource can not preempt each other.

Multiple processors can assert interrupt requests to each other through software settable interrupt requests. These same software settable interrupt requests also can be used to break the work involved in servicing an interrupt request into a high priority portion and a low priority portion. The high priority portion is initiated by a peripheral interrupt request, but then the ISR asserts a software settable interrupt request to finish the servicing in a lower priority ISR. Therefore these software settable interrupt requests can be used instead of the peripheral ISR scheduling a task through the RTOS. The INTC provides the following features:

- Unique 9-bit vector for each of the possible 128 separate interrupt sources
- Eight software triggerable interrupt sources
- 16 priority levels with fixed hardware arbitration within priority levels for each interrupt source
- Ability to modify the ISR or task priority
 - Modifying the priority can be used to implement the Priority Ceiling Protocol for accessing shared resources
- External non maskable interrupt directly accessing the main CPU critical interrupt mechanism
- 32 external interrupts

1.3.6 QuadSPI serial flash memory controller

The QuadSPI module enables use of external serial flash memories supporting single, dual, and quad modes of operation. It features the following:

- Maximum serial clock frequency 80 MHz
- Memory mapped read access for AHB crossbar switch masters
- Automatic serial flash read command generation by CPU, eDMA, DCU, or DCULite read access on AHB bus
- Supports single, dual, and quad serial flash read commands
- Simultaneous mode:
 - Supports concurrent read of two external serial flashes
 - The quad data streams from the two flashes can be recombined in the QuadSPI to achieve up to 80 MB/s read bandwidth with 80 MHz serial flash
- 16×64-bit buffer with speculative fetch and buffer flush mechanisms to maximize read bandwidth of serial flash
- DMA support
- All Serial Flash program, erase, read, and configuration commands available via IP bus interface

1.3.7 System Integration Unit Lite (SIUL)

The SIUL controls MCU reset configuration, pad configuration, external interrupt, general purpose I/O (GPIO), internal peripheral multiplexing, and the system reset operation.

The GPIO features the following:

- Up to four levels of internal pin multiplexing, allowing exceptional flexibility in the allocation of device functions for each package
- Centralized general purpose input output (GPIO) control
- All GPIO pins can be independently configured to support pull-up, pull down, or no pull
- Reading and writing to GPIO supported both as individual pins and 16-bit wide ports
- All peripheral pins can be alternatively configured as both general purpose input or output pins except ADC channels which support alternative configuration as general purpose inputs
- Direct readback of the pin value supported on all digital output pins through the SIU
- Configurable digital input filter that can be applied to up to 24 general purpose input pins for noise elimination on external interrupts
- Register configuration protected against change with soft lock for temporary guard or hard lock to prevent modification until next reset

1.3.8 On-chip flash memory with ECC

The MPC5645S microcontroller has the following flash memory features:

- 2 MB of flash memory
 - Typical flash memory access time: 0 wait-state for buffer hits, 3 wait-states for page buffer miss at 125 MHz
 - Two 4×128-bit page buffers with programmable prefetch control
 - One set of page buffers can be allocated for code-only, fixed partitions of code and data, all available for any access
 - One set of page buffers allocated to Display Controller Units, Graphics Accelerator, and the eDMA
 - 64-bit ECC with single-bit correction, double-bit detection for data integrity
- Small block flash arrangement to support features such as boot block, EEPROM Emulation, operating system block
 - 8×16 KB
 - 2×64 KB
 - 2×128 KB
 - 6×256 KB
- Hardware managed flash writes, erase and verify sequence
- Censorship protection scheme to prevent Flash content visibility

1.3.9 SRAM

The MPC5645S microcontroller has 64 KB general-purpose on-chip SRAM with the following features:

- Typical SRAM access time: 1 wait-state for reads and 32-bit writes
- 32-bit ECC with single-bit correction, double bit detection for data integrity
- Supports byte (8-bit), half word (16-bit), word (32-bit), and double-word (64-bit) writes for optimal use of memory
- User transparent ECC encoding and decoding for byte, half word, and word accesses
- Separate internal power domains applied to 56 KB and 8 KB SRAM blocks during STANDBY modes to retain contents during low power mode

1.3.10 On-chip graphics SRAM

The MPC5645S microcontroller has 1 MB on-chip graphics SRAM with the following features:

- Two crossbar slave ports:
 - One dedicated to the 2D Graphics Accelerator (GFX2D) access
 - One dedicated to all other crossbar masters
- Usable as general purpose SRAM
- Supports byte (8-bit), half word (16-bit), word (32-bit), and double-word (64-bit) writes for optimal use of memory
- RAM controller with hardware RAM fill function supporting all-zeroes or all-ones SRAM initialization
- Independent data buffers (one per AHB port) for maximum system performance
 - Optimized for burst transfers (read + write)
 - Programmable read prefetch capabilities

1.3.11 Memory Protection Unit (MPU)

The MPU features the following:

- Sixteen region descriptors for per master protection
- Start and end address defined with 32-byte granularity

- Overlapping regions supported
- Protection attributes can optionally include process ID
- Protection offered for 4 concurrent read ports
- Read and write attributes for all masters
- Execute and supervisor/user mode attributes for processor masters

1.3.12 2D Graphics Accelerator (GFX2D)

- Native vector graphics rendering
 - Compatible with OpenVG1.1
 - Complete hardware OpenVG 1.1 rendering pipeline
 - Both geometry and pixel processing
 - Adaptive processing of Bezier curves and strokes
- 16-sample edge anti-aliasing
 - High image quality, font scalability, etc.
 - 4× Rotated Grid Supersampling (RGSS) AA for Flash
- 3D perspective texturing, reflections, and shadowing
- Shading (linear or radial gradient)
- Separate 2D engine for BitBlt, fill, and ROP operations
- Significant performance improvement when compared to software or 3D GPU-based OpenVG implementations

1.3.13 Display Control Unit (DCU3)

The DCU3 is a display controller designed to drive TFT LCD displays up to WVGA resolution using direct blit graphics and video.

The DCU3 generates all the necessary signals required to drive the TFT LCD displays: up to 24-bit RGB data bus, Pixel Clock, Data Enable, Horizontal-Sync, and Vertical-Sync.

The flexible architecture of the DCU3 enables the display of OpenVG-rendered frame buffer content and direct blit rendered graphics simultaneously.

An optional Timing Controller (TCON) and RSDS interface is available to directly drive the row and column drivers of a display panel.

Internal memory resource of the device allows to easily handle complex graphics contents (pictures, icons, languages, fonts).

The DCU3 supports 4-plane blending and 16 graphics layers. Control Descriptors (CDs) associated with each of the 16 layers enable effective merging of different resolutions into one plane to optimize use of internal memory buffers. A layer may be constructed from graphic content of various resolutions including indexed colors of 1, 2, 4, and 8 bpp, direct colors of 16, 24, and 32 bpp, and a YUV 4:2:2 color space. The ability of the DCU3 to handle input data in resolutions as low as 1bpp, 2bpp, and 4bpp enables a highly efficient use of internal memory resources of the MPC5645S. A special tiled mode can be enabled on any of the 16 layers to repeat a pattern optimizing graphic memory usage.

A hardware cursor can be managed independently of the layers at blending level increasing the efficient use of the internal DCU3 resources.

To secure the content of all critical information to be displayed, a safety mode can be activated to check the integrity of critical data along the whole system data path from the memory to the TFT pads.

The DCU3 features the following:

- Display color depth: up to 24 bpp
- Generation of all RGB and control signals for TFT
- Four-plane blending

Overview

- Maximum number of Input Layers: 16 (fixed priority)
- Dynamic Look-Up-Table (Color and Gamma Look-Up)
- α -blending range: up to 256 levels
- Transparency Mode
- Gamma Correction
- Tiled mode on all the layers
- Hardware Cursor
- Supports YCrCb 4:2:2 input data format
- RLE decode inline supporting direct read of RLE compressed images from system memory
- Critical display content integrity monitoring for Functional Safety support
- Internal Direct Memory Access (DMA) module to transfer data from internal and / or external memory

The DCU3 also features a Parallel Data Interface (PDI) to receive external digital video or graphic content into the DCU3. The PDI input is directly injected into the DCU3 background plane FIFO. When the PDI is activated, all the DCU3 synchronization is extracted from the external video stream to guarantee the synchronization of the two video sources.

The PDI can be used to:

- Connect a video camera output directly to the PDI
- Connect a secondary display driver as slave with a minimum of extra cost
- Connect a device gathering various Video sources
- Provide flexibility to allow the DCU to be used in slave mode (external synchronization)

The PDI features the following:

- Supported color modes:
 - 8-bit mono
 - 8-bit color multiplexed
 - RGB565
 - 16-bit/18-bit RAW color
- Supported synchronization modes:
 - embedded ITU-R BT.656-4 (RGB565 mode 2)
 - HSYNC, VSYNC
 - Data Enable
- Direct interface with DCU3 background plane FIFO
- Synchronization generation for the DCU3

1.3.14 Display Control Unit Lite (DCULite)

The DCULite is a display controller designed to enable the MPC5645S to drive a second TFT LCD display up to XGA resolution using direct blit graphics and video. The DCULite includes all features of the DCU3, including the PDI with the following exceptions:

- Reduced from 4-plane to 2-plane blending
- Reduced from 16 layers to 4 layers
- Reduced CLUT size

1.3.15 Timing Controller (TCON) and RSDS interface

The TCON enables direct drive of the row and column drivers of display panels enabling emulation of TCON ICs used in display panels.

- Programmable Timing Generation unit featuring 12 waveform generators allowing high degree of flexibility in panel waveform generation
- Reduced Swing Differential Signaling (RSDS) interface for RGB data and pixel clock
- Conforms to “RSDS ‘Intra Panel’ Interface Specification” Rev. 1.0 (National Semiconductor)

1.3.16 RLE decoder

The RLE decoder is a crossbar slave sharing a slave port with the QuadSPI module. The platform eDMA is used to stream compressed image data into and extract decompressed data out of the RLE Decoder.

- Lossless decompression
- Pixel formats supported: 8 bpp, 16 bpp, 24 bpp, and 32 bpp
- AHB mapped read and write registers in RLE_DEC to achieve higher throughput
- Programmable fill levels of read and write buffers for initiating burst transfers
- Crop feature: Support for selectively reading out a part of decompressed image data taking complete compressed data for the full image as input

1.3.17 DRAM controller

The DRAM controller is a multi-port DRAM controller supporting LPDDR1, DDR-1, and DDR-2 memories. The DRAM controller listens to the incoming requests to the seven buses in parallel and then sends commands to the DRAM from the highest priority bus at the current time

The seven incoming 64-bit buses are:

- DCU3
- DCULite
- e200z4d core — instruction bus
- e200z4d core — data bus
- VIU2
- GFX2D
- eDMA

The DRAM controller features the following:

- Supports CAS latency of 2, 3, and 4 clock cycles
- Master buses
 - 7 incoming master buses
 - Supports 16-byte and 32-byte bursts
 - Supports byte enables
 - Supports 4-bit priority signal for each bus
- Write buffer contains five 32-byte entries
- Supports 16-wide and 32-wide DDR1, DDR2, and LPDDR1 DRAM devices
- Controller supports one chip select, 8-bank DRAM system
- Supports dynamic on-die termination in the host device and in the DRAM
- Supports memory sizes as small as 64 Mbit

1.3.18 Video Input Unit (VIU2)

The VIU2 is a crossbar master module accepting an ITU656 compatible video input stream on a parallel interface, converting the pixel data to RGB or YUV format and transferring the video image to internal frame buffer memory or external DRAM if available.

- Supports 8-bit/10-bit ITU656 video input
- Output formats:
 - RGB888
 - RGB565
 - 8-bit monochrome
 - YCrCb 4:2:2
- Video downscaling
- Contrast and Brightness adjustment
- De-interlace for interlaced video image
- Internal DMA engine for data transfer to memory

1.3.19 Boot Assist Module (BAM)

The BAM is a block of read-only memory that is programmed once by Freescale. The BAM program is executed every time the MCU is powered-on or reset in normal mode. The BAM supports different modes of booting. They are:

- Booting from internal flash memory
- Serial boot loading (A program is downloaded into RAM via FlexCAN or LINFlex and then executed)
- Booting from external memory

Additionally the BAM:

- Enables and manages the transition of the MCU from reset to user code execution
- Configures device for serial bootloader
- Enables multiple bootcode starting locations out of reset through implementation of search for valid Reset Configuration Halfword

1.3.20 Enhanced Modular Input/Output System (eMIOS)

This device has two eMIOS modules, each with 16 channels supporting a range of 16-bit Input Capture, Output Compare, Pulse Width Modulation, and Quadrature Decode functions.

- Selectable clock source from primary FMPLL, secondary FMPLL, external 4 - 16 MHz oscillator or 16 MHz Internal RC oscillator on a per module basis
- Timed I/O channels with 16-bit counter resolution
- Buffered updates
- Support for shifted PWM outputs to minimize occurrence of concurrent edges
- Edge aligned output pulse width modulation
 - Programmable pulse period and duty cycle
 - Supports 0% and 100% duty cycle
 - Shared or independent time bases
- Programmable phase shift between channels
- 4 channels of Quadrature Decode
- DMA transfer support

1.3.21 Analog-to-Digital Converter (ADC)

The ADC features the following:

- 10-bit A/D resolution
- 0–5 V or 0–3.3 V common mode conversion range
- Supports conversions speeds of up to 1 μ s
- 20 internal and 8 external channels support
- Up to 20 single-ended inputs channels
 - 10 channels configured as input only pins
 - 10-bit \pm 2 counts accuracy (TUE)
 - 10 channels configured to have alternate function as general purpose input/output pins
 - 10-bit \pm 3 counts accuracy (TUE)
- External multiplexer support to increase up to 27 channels
 - Automatic 1 \times 8 multiplexer control
 - External multiplexer connected to a dedicated input channel
 - Shared register between the 8 external channels
- Result register available for every non-multiplexed channel
- Configurable Left or Right aligned result format
- Supports for one-shot, scan, and injection conversion modes
- Injection mode status bit implemented on adjacent 16-bit register for each result
 - Supports Access to Result and injection status with single 32-bit read
- Independently enabling of function for channels:
 - Pre-sampling
 - Offset error cancellation
 - Offset Refresh
- Conversion Triggering support
 - Internal conversion triggering from periodic interrupt timer (PIT)
- Four configurable analog comparator channels offering range comparison with triggered alarm
 - Greater than
 - Less than
 - Out of range
- All unused analog pins available as general purpose input pins
- Selected unused analog pins available as general purpose pins
- Power Down mode
- Optional support for DMA transfer of results

1.3.22 Deserial Serial Peripheral Interface (DSPI)

The DSPI modules provide a synchronous serial interface for communication between the MCU and external devices.

The DSPI features:

- Full duplex, synchronous transfers
- Master or slave operation
- Programmable master bit rates
- Programmable clock polarity and phase
- End-of-transmission interrupt flag
- Programmable transfer baud rate

Overview

- Programmable data frames from 4 to 16 bits
- Up to 3 chip select lines available, depending on package and pin multiplexing, enable 8 external devices to be selected using external muxing from a single DSPI
- Eight clock and transfer attributes registers
- Chip select strobe available as alternate function on one of the chip select pins for de-glitching
- FIFOs for buffering up to 4 transfers on the transmit and receive side
- General purpose I/O functionality on pins when not used for SPI
- Queueing operation possible through use of eDMA

1.3.23 FlexCAN

The MPC5645S includes up to three controller area network (FlexCAN) modules. The FlexCAN module is a communication controller implementing the CAN protocol according to Bosch Specification version 2.0B. The CAN protocol was designed to be used primarily as a vehicle serial data bus, meeting the specific requirements of this field: real-time processing, reliable operation in the EMI environment of a vehicle, cost-effectiveness, and required bandwidth.

Each FlexCAN module offers the following:

- Compliant with CAN protocol specification, Version 2.0B active
- 64 mailboxes, each configurable as transmit or receive
 - Mailboxes configurable while module remains synchronized to CAN bus
- Transmit features
 - Supports configuration of multiple mailboxes to form message queues of scalable depth
 - Arbitration scheme according to message ID or message buffer number
 - Internal arbitration to guarantee no inner or outer priority inversion
 - Transmit abort procedure and notification
- Receive features
 - Individual programmable filters for each mailbox
 - 8 mailboxes configurable as a 6-entry receive FIFO
 - 8 programmable acceptance filters for receive FIFO
- Programmable clock source
 - System clock
 - Direct oscillator clock to avoid PLL jitter
- Listen only mode capabilities
- CAN Sampler
 - Can catch the 1st message sent on the CAN network while the MCU is stopped, which guarantees a clean startup of the system without missing messages on the CAN network
 - The CAN sampler is connected to one of the CAN RX pins

1.3.24 Serial communication interface module (LINFlex)

The MPC5645S devices include up to four LINFlex modules and support for LIN Master mode, LIN Slave mode, and UART mode. The modules are LIN state machine compliant to the LIN 1.3, 2.0, and 2.1 Specifications and handle LIN frame transmission and reception without CPU intervention.

Other features include:

- Autonomous LIN frame handling
- Message buffer to store identifier and up to eight data bytes
- Supports message length of up to 64 bytes

- Detection and flagging of LIN errors
- Sync field; Delimiter; ID parity; Bit, Framing; Checksum and Timeout errors
- Classic or extended checksum calculation
- Configurable Break duration of up to 36-bit times
- Programmable Baud rate prescalers (13-bit mantissa, 4-bit fractional)
- Diagnostic features
 - Loop back
 - Self Test
 - LIN bus stuck dominant detection
- Interrupt driven operation with 16 interrupt sources
- LIN slave mode features
 - Autonomous LIN header handling
 - Autonomous LIN response handling
 - Discarding of irrelevant LIN responses using up to 16 ID filters
- UART mode
 - Full-duplex operation
 - Standard non return-to-zero (NRZ) mark/space format
 - Data buffers with 4-byte receive, 4-byte transmit
 - Configurable word length (8-bit or 9-bit words)
 - Error detection and flagging
 - Parity, noise, and framing errors
 - Interrupt driven operation with 4 interrupts sources
 - Separate transmitter and receiver CPU interrupt sources
 - 16-bit programmable baud-rate modulus counter and 16-bit fractional
 - Two receiver wakeup methods

1.3.25 Inter-Integrated Circuit (I²C) controller modules

The MPC5645S includes four I²C modules. Each module features the following:

- Two-wire bi-directional serial bus for on-board communications
- Compatibility with I²C bus standard
- Multi-master operation
- Software-programmable for one of 256 different serial clock frequencies
- Software-selectable acknowledge bit
- Interrupt-driven, byte-by-byte data transfer
- Arbitration-lost interrupt with automatic mode switching from master to slave
- Calling address identification interrupt
- Start and stop signal generation/detection
- Repeated START signal generation
- Acknowledge bit generation/detection
- Bus-busy detection

1.3.26 System clocks and clock generation modules

The system clock on the MPC5645S can be derived from an external oscillator, an on-chip FMPLL, or the internal 16 MHz oscillator.

Overview

The source system clock frequency can be changed via an on-chip programmable clock divider ($\div 1$ to $\div 32$). An additional programmable peripheral bus clock divider (ratios $\div 1$ to $\div 15$) is also available.

The MPC5645S has two on-chip FMPLLs (primary and secondary). Each features the following:

- Input clock frequency from 4 MHz to 16 MHz
- Lock detect circuitry continuously monitors lock status
- Loss Of Clock (LOC) detection for reference and feedback clocks
- On-chip loop filter (for improved electromagnetic interference performance and reduction of number of external components required)
- Support for frequency ramping from PLL

The primary FMPLL module is for use as a system clock source. The secondary FMPLL is available for use as an alternate, modulated or non-modulated clock source to eMIOS modules and as alternate clock to the DCU for pixel clock generation.

The fast external oscillator provides the following features:

- Input frequency range 4–16 MHz
- Square-wave input mode
- Oscillator input mode 3.3 V (5.0 V)
- Automatic level control
- Low power consumption
- PLL reference

The MPC5645S also includes the following oscillators:

- 32 KHz low power external oscillator for slow execution, low power, and RTC
- Dedicated internal 128 kHz RC oscillator for low power mode operation and self wake-up
 - $\pm 10\%$ accuracy across voltage and temperature (after factory trimming)
 - Trimming registers to support improved accuracy with in-application calibration
- Dedicated 16 MHz internal RC oscillator
 - Used as default clock source out of reset
 - Provides a clock for rapid start-up from low power modes
 - Provides a back-up clock in the event of PLL or External Oscillator clock failure
 - Offers an independent clock source for the SWT
 - $\pm 5\%$ accuracy across voltage and temperature (after factory trimming)
 - Trimming registers to support frequency adjustment with in-application calibration

1.3.27 Periodic Interrupt Timer (PIT)

The PIT features the following:

- Eight general purpose interrupt timers
- Two dedicated interrupt timers for triggering ADC conversions
- 32-bit counter resolution
- Clocked by system clock frequency

1.3.28 Real Time Counter (RTC)

The Real Time Counter supports wake-up from Low Power modes or Real Time Clock generation

- Configurable resolution for different timeout periods
 - 1 s resolution for >1 hour period
 - 1 ms resolution for 2 second period

- Selectable clock sources from external 32 KHz crystal, external 4–16 MHz crystal, internal 128 kHz RC oscillator or divided internal 16 MHz RC oscillator

1.3.29 System Timer Module (STM)

The STM is a 32-bit timer designed to support commonly required system and application software timing functions. The STM includes a 32-bit up counter and four 32-bit compare channels with a separate interrupt source for each channel. The counter is driven by the system clock divided by an 8-bit prescale value (1 to 256).

- One 32-bit up counter with 8-bit prescaler
- Four 32-bit compare channels
- Independent interrupt source for each channel
- Counter can be stopped in debug mode

1.3.30 Software Watchdog Timer (SWT)

The SWT features the following:

- Watchdog supporting software activation or enabled out of Reset
- Supports normal or windowed mode
- Watchdog timer value writable once after reset
- Watchdog supports optional halting during low power modes
- Configurable response on timeout: reset, interrupt, or interrupt followed by reset
- Clock source: 128 kHz RC oscillator

1.3.31 Stepper Motor Controller (SMC)

The SMC module is a PWM motor controller suitable to drive instruments in a cluster configuration or any other loads requiring a PWM signal. The motor controller has twelve PWM channels associated with two pins each (24 pins in total) driving up to 6 stepper motors.

The SMC module includes the following features:

- 10/11-bit PWM counter
- 11-bit resolution with selectable PWM dithering function
- Left, right, or center aligned PWM
- Output slew rate control
- Output Short Circuit Detection

This module is suited for, but not limited to, driving small stepper and air core motors used in instrumentation applications. This module can be used for other motor control or PWM applications that match the frequency, resolution, and output drive capabilities of the module.

1.3.32 Stepper Stall Detect (SSD)

The SSD module provides a circuit to measure and integrate the induced voltage on the non-driven coil of a stepper motor using full steps when the gauge pointer is returning to zero (RTZ).

The SSD module features the following:

- Programmable full step state
- Programmable integration polarity
- Blanking (recirculation) state
- 16-bit integration accumulator register

Overview

- 16-bit modulus down counter with interrupt

1.3.33 Sound Generator Module (SGM)

The SGM features the following:

- 4-channel audio mixer
- Each channel capable of independent Tone generation or Wave playback
- Individual channel volume control (8-bit resolution)
- Tone Mode:
 - Programmable Tone frequency
 - Programmable amplitude envelope: attack, duration, and decay
 - Programmable number of tone pulses and inter-tone duration
- Wave Mode:
 - One FIFO per channel working in conjunction with eDMA
 - Supports standard audio sampling rates (4 kHz, 8 kHz, 11.025 kHz, 16 kHz, 22.050 kHz, 32 kHz, 44.100 kHz, 48 kHz)
 - Same sample rate applies to all channels
 - 8-bit, 12-bit, 16-bit input data formats
 - Programmable wave duration and inter-wave duration
 - Repeat mode with programmable number of wave playbacks
- SGM Output:
 - 16-bit PWM channel
 - Integrated I²S master interface for connection to external audio DAC

1.3.34 IEEE 1149.1 JTAG controller (JTAGC)

JTAGC features the following:

- Backward compatible to standard JTAG IEEE 1149.1-2001 test access port (TAP) interface
- Support for boundary scan testing

1.3.35 Nexus Development Interface (NDI)

The Nexus 3 module is compliant with Class 3 of the IEEE-ISTO 5001-2008 standard, with additional Class 4 features available. The following features are implemented:

- Program Trace via Branch Trace Messaging (BTM). Branch trace messaging displays program flow discontinuities (direct and indirect branches, exceptions, etc.), allowing the development tool to interpolate what transpires between the discontinuities. Thus static code may be traced.
- Data Trace via Data Write Messaging (DWM) and Data Read Messaging (DRM). This provides the capability for the development tool to trace reads and/or writes to selected internal memory resources.
- Ownership Trace via Ownership Trace Messaging (OTM). OTM facilitates ownership trace by providing visibility of which process ID or operating system task is activated. An Ownership Trace Message is transmitted when a new process/task is activated, allowing the development tool to trace ownership flow.
- Run-time access to embedded processor memory map via the JTAG port. This allows for enhanced download/upload capabilities.
- Watchpoint Messaging via the auxiliary pins provides visibility when debugging.
- Watchpoint Trigger enablement of Program and/or Data Trace Messaging enhances debug capability.

- Data Acquisition Messaging (DQM) allows code to be instrumented to export customized information to the Nexus Auxiliary Output Port.
- Address Translation Messaging via program correlation messages displays updates to the TLB for use by the debugger in correlating virtual and physical address information.
- Auxiliary interface for higher data input/output.
- Registers for Program Trace, Data Trace, Ownership Trace, and Watchpoint Trigger.
- All features are controllable and configurable via the JTAG port.
- Nexus Auxiliary port is supported on the 416BGA package.

2 Pinout and signal descriptions

2.1 176 LQFP package pinout

Figure 2 shows the pinout for the 176-pin LQFP package.

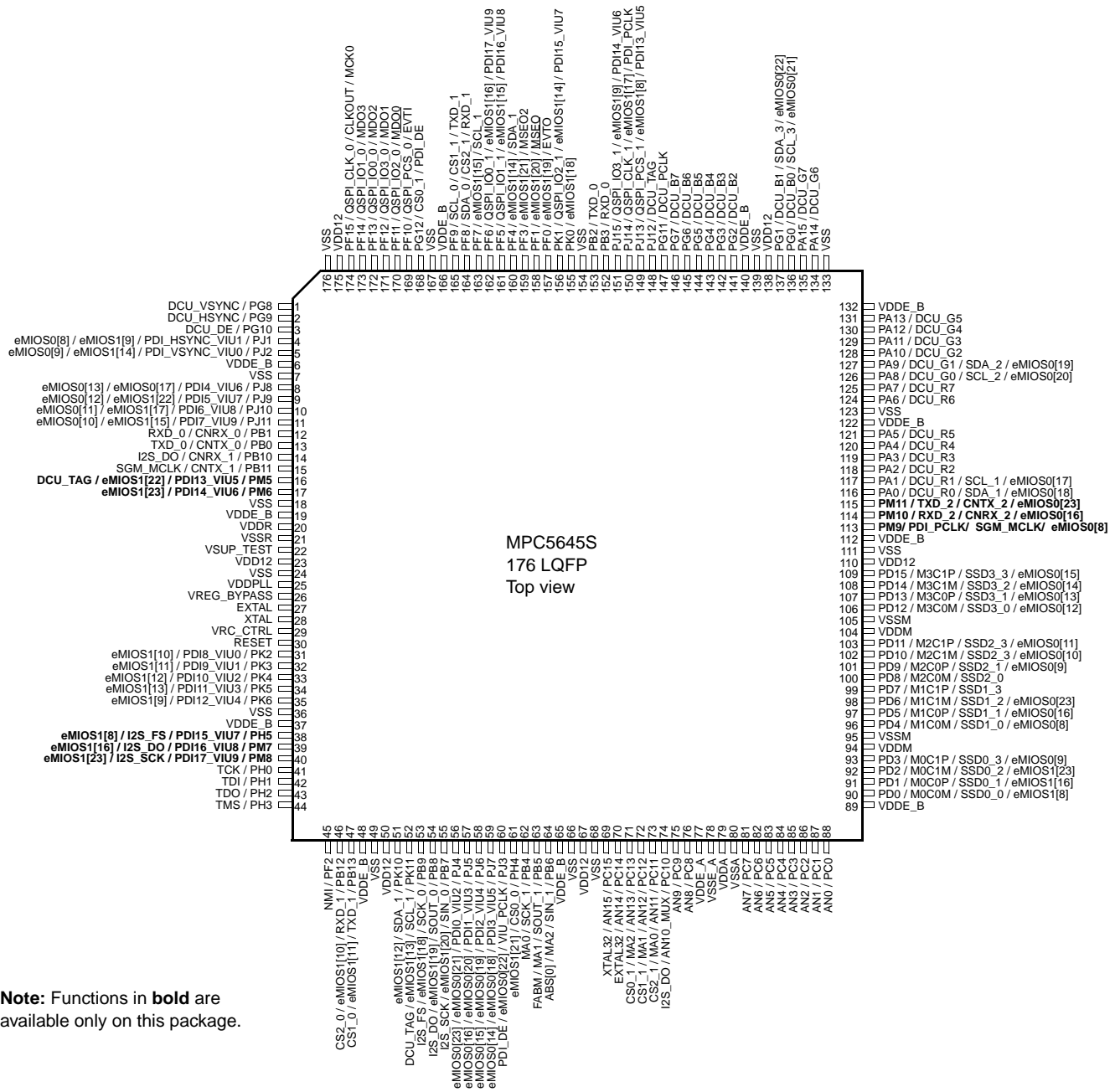

Figure 2. 176-pin LQFP pinout

2.2 208 LQFP package pinout

Figure 3 shows the pinout for the 208-pin LQFP package.

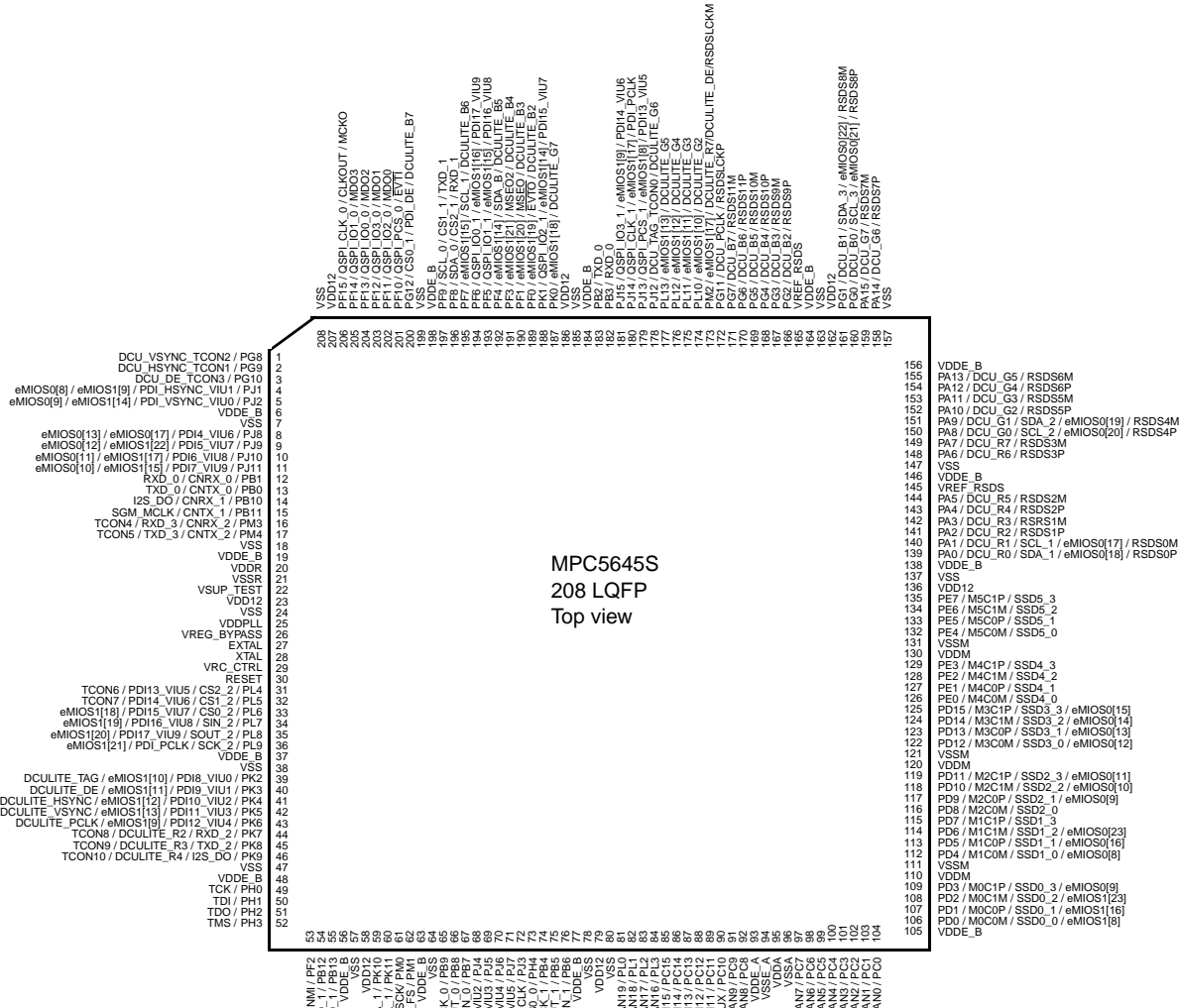

Figure 3. 208-pin LQFP pinout

2.3 416 TEPBGA package pinout

Figure 4 shows the pinout for the 416 TEPBGA package.

	1	2	3	4	5	6	7	8	9	10	11	12	13	14	15	16	17	18	19	20	21	22	23	24	25	26								
A	ddr_dq[26]	ddr_dq[27]	ddr_dq[28]	ddr_dq[29]	30]	31]	ddr_ba[0]	ddr_ba[1]	ddr_ba[2]	ddr_addr[0]	ddr_addr[4]	ddr_addr[6]	ddr_addr[8]	ddr_addr[12]	PG12	PF14	PF10	PF8	PF5	PF3	PK0	PB3	PJ12	PL11	PG7	PG6								
B	ddr_dq[25]	VSS	ddr_dqs[3]	ddr_dm[3]	VSS	ddr_cas	ddr_ras	VSS	ddr_web	ddr_addr[1]	VSS	ddr_addr[7]	ddr_addr[9]	VSS	ddr_addr[15]	PF13	VDDE	PF15	VSS	PF1	VDDE	PJ15	PL13	VDDE	VSS	PG5								
C	ddr_dq[23]	VDDE_DDR	VSS	ddr_dq[24]	VDDE_DDR	VSS	ddr_dram_clk	VDDE_DDR	VSS	ddr_addr[2]	VDDE_DDR	VSS	ddr_addr[10]	VDDE_DDR	VSS	PF12	VSS	PF7	VDDE	PF0	VSS	PJ14	PL12	PL10	PG3	PG4								
D	ddr_dq[21]	ddr_dq[20]	ddr_dq[21]	ddr_dq[22]	ddr_odt	VDD33_DR	ddr_dram_clkb	ddr_cke	ddr_cs	ddr_addr[3]	ddr_addr[5]	VDD33_DR	ddr_addr[11]	ddr_addr[13]	ddr_addr[14]	PF11	PF9	PF6	PF4	PK1	PB2	PJ13	PM2	VREF_RSDS2	PG2	PG1								
E	ddr_dq[17]	VSS	VDDE_DDR	ddr_dq[18]																			PG11	VSS	VDDE	PG0								
F	ddr_dq[16]	MVTT3	VSS	VDD33_DR																			PA15	PA14	PA13	PA12								
G	ddr_dq[15]	ddr_dqs[2]	ddr_dm[2]	ddr_dq[14]																			PA11	PA9	PA8	PA7								
H	ddr_dq[13]	VSS	VDDE_DDR	ddr_dq[12]																			PA10	VDDE	VSS	VA6								
J	ddr_dq[11]	MVTT2	VSS	MVREF																			PA3	VREF_RSDS1	PA5	PA4								
K	ddr_dq[9]	ddr_dqs[1]	ddr_dm[1]	ddr_dq[10]	VDD12								VSS	VDD12	VSS	VDD12	VSS	VDD12	VSS	VDD12	VSS									PA2	VSS	PA1	PA0	
L	ddr_dq[8]	VSS	VDDE_DDR	ddr_dq[7]	VSS								VDD12	VSS	VDD12	VSS	VDD12	VSS	VDD12	VSS	VDD12	VSS									PM13	PM12	VDDE	PJ0
M	ddr_dq[5]	MVTT1	VSS	ddr_dq[6]	VDD12								VSS	VSS	VSS	VSS	VSS	VSS	VDD12	VSS									PO7	PO6	PO5	PO4		
N	ddr_dq[3]	ddr_dqs[0]	VDDE_DDR	ddr_dq[4]	VSS								VDD12	VSS	VSS	VSS	VSS	VSS	VSS	VDD12									PO3	VDDE	PO2	PO1		
P	ddr_dq[1]	VSS	ddr_dm[0]	ddr_dq[2]	VDD12								VSS	VSS	VSS	VSS	VSS	VSS	VDD12	VSS									PO0	PN15	P25	PN14		
R	ddr_dq[0]	MVTT0	VSS	VDD33_DR	VSS								VDD12	VSS	VSS	VSS	VSS	VSS	VSS	VDD12									PE7	PE6	PN13	PN12		
T	PG10	PG9	VDDE_DDR	PG8	VDD12								VSS	VDD12	VSS	VDD12	VSS	VDD12	VSS	VDD12	VSS									PE5	PE4	PE3	PE2	
U	PJ9	PJ8	PJ2	PJ1	VSS								VDD12	VSS	VDD12	VSS	VDD12	VSS	VDD12	VSS	VDD12									PE1	VSSM	VDDM	PE0	
V	PB1	VSS	PJ11	PJ10																			PD15	PD14	PD13	PD12								
W	RESET	PB10	VDDE	PB0																			PD11	VDDM	VSSM	PD10								
Y	VSS	PM4	PM3	PB11																			PD9	PD8	PD7	PD6								
AA	XTAL	VREG_BY_PASS	VRC_CTRL	VDDREG																			PD5	VSSM	VDDM	PD4								
AB	EXTAL	PL4	VSS	VDDPLL																			PD3	PD2	PD1	PD0								
AC	VSUP_TEST	PL5	PN0	PK4	PK6	PH0	PF2	PB13	PK11	PN2	PN4	PN8	PB9	PB7	PJ7	PB5	MCKO	MDO6	MDO10	MVO0	PC0	VDDA	VSSEH_ADC	PC3	PC1	PC2								
AD	PL6	VDDE	PN1	VSS	PK7	PH1	VDDE	EVTI	MSEO	VSS	PN5	PN9	VDDE	PJ4	PJ3	VSS	MSEO2	MDO7	VDDE	MDO1	PC6	VSSA	VDDEH_ADC	PC4	PC7	PC5								
AE	PL7	VSS	PK2	VDDE	PK8	PH2	VSS	EVTO	PM0	VDDE	PN6	PN10	VSS	PJ5	PH4	VDDE	MDO4	MDO8	VSS	MDO2	PL1	PL0	PC10	PC11	PC9	PC8								
AF	PL8	PL9	PK3	PK5	PK9	PH3	PB12	PK10	PM1	PN3	PN7	PN11	PB8	PJ6	PB4	PB6	MDO5	MDO9	MDO11	MDO3	PL3	PL2	PC15	PC14	PC13	PC12								
	1	2	3	4	5	6	7	8	9	10	11	12	13	14	15	16	17	18	19	20	21	22	23	24	25	26								

Figure 4. 416 TEPBGA pinout

2.4 Signal description

The following sections provide signal descriptions and related information about the signals' functionality and configuration.

2.4.1 Pad configuration during reset phases

All pads have a fixed configuration under reset.

During the power-up phase, all pads are forced to tristate.

After power-up phase, all pads are floating with the following exceptions:

- PB[5] (FAB) is pull-down. Without external strong pull-up the device starts fetching from flash memory.
- RESET pad is driven low. This is released only after PHASE2 reset completion.
- Fast (4-16 MHz) external oscillator pads (EXTAL, XTAL) are tristate.
- The following pads are pull-up:
 - PB[6]
 - PH[0]
 - PH[1]
 - PH[3]

2.4.2 Voltage supply pins

Voltage supply pins are used to provide power to the device. Two dedicated pins are used for 1.2 V regulator stabilization.

Table 3. Voltage supply pin descriptions

Supply pin	Function	Pin number		
		176 LQFP	208 LQFP	416 TEPBGA
V_{DD12}^1	1.2 V core supply (1.08 V - 1.32 V)	23, 50, 67, 110, 138, 175	23, 58, 79, 136, 162, 186, 207	K10,K12,K14,K16,L11,L13,L15,L17,M10,M16,N11,N17,P10,P16,R11,R17,T10,T12,T14,T16,U11,U13,U15,U17
V_{SS}	1.2 V ground	7, 18, 36, 49, 66, 68, 111, 123, 133, 139, 154, 167, 176	7, 18, 38, 47, 57, 64, 78, 80, 137, 147, 157, 163, 185, 199, 208	AB3,AD10,AD16,AD4,AE13,AE19,AE2,AE7,B11,B14,B19,B2,B25,B5,B8,C12,C15,C17,C21,C3,C6,C9,E2,E24,F3,H2,H25,J3,K11,K13,K15,K17,K24,L10,L12,L14,L16,L2,M11,M12,M13,M14,M15,M17,M3,N10,N12,N13,N14,N15,N16,P11,P12,P13,P14,P15,P17,P2,P25,R10,R12,R13,R14,R15,R16,R3,T11,T13,T15,T17,U10,U12,U14,U16,V2,Y1
	VDD12 ground and VDDPLL ground (VSSPLL)	24	24	—
V_{DDE_B}	3.3 V I/O supply. This supply is shared with internal flash, 16 MHz IRC oscillator and 4–16MHz crystal oscillator.	6, 19, 37, 48, 65, 89, 112, 122, 132, 140, 166	6, 19, 37, 48, 56, 63, 77, 105, 138, 146, 156, 164, 184, 198	AD13,AD19,AD2,AD7,AE10,AE16,AE4,B17,B21,B24,C19,E25,H24,L25,N24,W3
V_{DDA}^2	3.3 V/5 V reference voltage and analog supply for A/D converter. This supply is shared with the SXOSC.	79	95	AC22
V_{SSA}	Reference ground and analog ground for A/D converter	80	96	AD22
V_{DDR}	Voltage regulator VREG supply	20	20	AA4
V_{SSR}	Voltage regulator ground	21	21	—
$V_{DDE_A}^2$	3.3 V/5 V I/O supply. This supply is shared with the SXOSC.	77	93	AD23
V_{SSE_A}	3.3 V/5 V I/O supply ground	78	94	AC23
V_{DDM}	Stepper motor 3.3 V/5 V pad supply. SSD shares this supply.	94, 104	110, 120, 130	U25,W24,AA25
V_{SSM}	Stepper motor ground	95, 105	111, 121, 131	U24,W24,AA24

Table 3. Voltage supply pin descriptions (continued)

Supply pin	Function	Pin number		
		176 LQFP	208 LQFP	416 TEPBGA
V _{DDPLL}	1.2 V PLL supply	25	25	AB4
V _{SUP_TEST} ³	9 V - 12 V flash test analog write signal	22	22	AC1
V _{DD_DR}	1.8V, 2.5V, and 3.3V DDR SDRAM supply	—	—	C2,C5,C8,C11,C14, E3,H3,L3,N3,T3
V _{DD33_DR}	Functional supply for SDRAM pads (where available must be \geq V _{DD_DR})	—	—	D6, D12, F4, R4

¹ Decoupling capacitors must be connected between these pins and the nearest V_{SS} pin.

² V_{DDA} must be at the same voltage as V_{DDDE_A}.

³ This signal needs to be connected to ground during normal operation.

2.4.3 System pins

The system pins are listed in Table 4.

Table 4. System pin descriptions

System pin	Function	I/O direction	Pad type	RESET configuration ¹	Pin number		
					176 LQFP	208 LQFP	416 TEPBGA
$\overline{\text{RESET}}$	Bidirectional reset with Schmitt-Trigger characteristics and noise filter.	I/O	M	Input, weak pull up	30	30	W1
EXTAL	Analog input to the oscillator amplifier circuit. Input for the clock generator in bypass mode.	I	X	—	27	27	AB1
XTAL	Analog output of the oscillator amplifier circuit. Needs to be grounded if oscillator bypass mode is used.	O	X	—	28	28	AA1
EXTAL32	Analog input of the 32KHz oscillator amplifier circuit.	O	S	—	70	86	AF24
XTAL32	Analog output of the 32 KHz oscillator amplifier circuit. Input for the clock generator in bypass mode.	I	S	—	69	85	AF23

Table 4. System pin descriptions (continued)

System pin	Function	I/O direction	Pad type	RESET configuration ¹	Pin number		
					176 LQFP	208 LQFP	416 TEPBGA
NMI	Non-Maskable Interrupt	I/O	S	Input, none	45	53	AC7
VRC_CTRL	Voltage Regulator external NPN Ballast base control pin		Analog	—	29	29	AA3
VREF_RSDS ²	RSDS interface reference voltage		Analog	—	—	145, 165	J24,D24
VREG_BYPASS ³	Pin used for factory testing	I	—	—	26	26	AA2

¹ Reset configuration is given as I/O direction and pull direction (for example, "Input, pullup").

² Although this signal is not a supply for RSDS pads, it needs to be terminated in an external capacitor with a value of 47 pF.

³ VREG_BYPASS should be connected to ground during normal operation.

2.4.4 Nexus pins

On the 176 LQFP and the 208 LQFP package options a reduced set of Nexus pins are optionally available, multiplexed with GPIO pins.

On the 416 TEPBGA package option all Nexus pins are dedicated to Nexus only.

Table 5. Nexus pins

System pin	Function	Pad type	PCR	Pin number ¹		
				176 LQFP	208 LQFP	416 TEPBGA
EVTI	Nexus Event In	M	PCR[80]	169	201	A17
EVTO	Nexus Event Out	M	PCR[70]	157	189	C20
MCKO	Nexus Msg Clock Out	F	PCR[85]	174	206	B18
MSEO[0]	Nexus Msg Start/End Out	M	PCR[71]	158	190	B20
MSEO[2]	Nexus Msg Start/End Out	M	PCR[73]	159	191	A20
MDO[0]	Nexus Msg Data Out	M	PCR[81]	170	202	D16
MDO[1]	Nexus Msg Data Out	M	PCR[82]	171	203	C16
MDO[2]	Nexus Msg Data Out	M	PCR[83]	172	204	B16
MDO[3]	Nexus Msg Data Out	M	PCR[84]	173	205	A16
EVTI	Nexus Event In	M	PCR[197]	n/a	n/a	AD8
EVTO	Nexus Event Out	M	PCR[198]	n/a	n/a	AE8
MCKO	Nexus Msg Clock Out	F	PCR[200]	n/a	n/a	AC17
MSEO[0]	Nexus Msg Start/End Out	M	PCR[199]	n/a	n/a	AD9
MSEO[2]	Nexus Msg Start/End Out	M	PCR[201]	n/a	n/a	AD17
MDO[0]	Nexus Msg Data Out	M	PCR[185]	n/a	n/a	AC20

Table 5. Nexus pins (continued)

System pin	Function	Pad type	PCR	Pin number ¹		
				176 LQFP	208 LQFP	416 TEPBGA
MDO[1]	Nexus Msg Data Out	M	PCR[186]	n/a	n/a	AD20
MDO[2]	Nexus Msg Data Out	M	PCR[187]	n/a	n/a	AE20
MDO[3]	Nexus Msg Data Out	M	PCR[188]	n/a	n/a	AF20
MDO[4]	Nexus Msg Data Out	M	PCR[189]	n/a	n/a	AE17
MDO[5]	Nexus Msg Data Out	M	PCR[190]	n/a	n/a	AF17
MDO[6]	Nexus Msg Data Out	M	PCR[191]	n/a	n/a	AC18
MDO[7]	Nexus Msg Data Out	M	PCR[192]	n/a	n/a	AD18
MDO[8]	Nexus Msg Data Out	M	PCR[193]	n/a	n/a	AE18
MDO[9]	Nexus Msg Data Out	M	PCR[194]	n/a	n/a	AF18
MDO[10]	Nexus Msg Data Out	M	PCR[195]	n/a	n/a	AC19
MDO[11]	Nexus Msg Data Out	M	PCR[196]	n/a	n/a	AF19

¹ On the 176 LQFP and 208 LQFP package options the Nexus pins are multiplexed with other GPIO. On the 416 TEPBGA package, there are additional dedicated Nexus pins.

2.4.5 DRAM interface

The DRAM interface pins are listed in [Table 6](#).

Table 6. DRAM interface pin summary

Port pin ¹	Function	I/O direction	Pad type	PCR	RESET config ²	Pin number
						416 TEPBGA
DRAM Data Bus						
DDR_DQ[31]	DRAM Data Bus [31]	I/O	DDR	PCR[237]	None, None	A6
DDR_DQ[30]	DRAM Data Bus [30]	I/O	DDR	PCR[238]	None, None	A5
DDR_DQ[29]	DRAM Data Bus [29]	I/O	DDR	PCR[239]	None, None	A4
DDR_DQ[28]	DRAM Data Bus [28]	I/O	DDR	PCR[240]	None, None	A3
DDR_DQ[27]	DRAM Data Bus [27]	I/O	DDR	PCR[241]	None, None	A2
DDR_DQ[26]	DRAM Data Bus [26]	I/O	DDR	PCR[242]	None, None	A1
DDR_DQ[25]	DRAM Data Bus [25]	I/O	DDR	PCR[243]	None, None	B1
DDR_DQ[24]	DRAM Data Bus [24]	I/O	DDR	PCR[244]	None, None	C4
DDR_DQ[23]	DRAM Data Bus [23]	I/O	DDR	PCR[245]	None, None	C1
DDR_DQ[22]	DRAM Data Bus [22]	I/O	DDR	PCR[246]	None, None	D4
DDR_DQ[21]	DRAM Data Bus [21]	I/O	DDR	PCR[247]	None, None	D3
DDR_DQ[20]	DRAM Data Bus [20]	I/O	DDR	PCR[248]	None, None	D2
DDR_DQ[19]	DRAM Data Bus [19]	I/O	DDR	PCR[249]	None, None	D1

Table 6. DRAM interface pin summary (continued)

Port pin ¹	Function	I/O direction	Pad type	PCR	RESET config ²	Pin number
						416 TEPBGA
DDR_DQ[18]	DRAM Data Bus [18]	I/O	DDR	PCR[250]	None, None	E4
DDR_DQ[17]	DRAM Data Bus [17]	I/O	DDR	PCR[251]	None, None	E1
DDR_DQ[16]	DRAM Data Bus [16]	I/O	DDR	PCR[252]	None, None	F1
DDR_DQ[15]	DRAM Data Bus [15]	I/O	DDR	PCR[253]	None, None	G1
DDR_DQ[14]	DRAM Data Bus [14]	I/O	DDR	PCR[254]	None, None	G4
DDR_DQ[13]	DRAM Data Bus [13]	I/O	DDR	PCR[255]	None, None	H1
DDR_DQ[12]	DRAM Data Bus [12]	I/O	DDR	PCR[256]	None, None	H4
DDR_DQ[11]	DRAM Data Bus [11]	I/O	DDR	PCR[257]	None, None	J1
DDR_DQ[10]	DRAM Data Bus [10]	I/O	DDR	PCR[258]	None, None	K4
DDR_DQ[9]	DRAM Data Bus [9]	I/O	DDR	PCR[259]	None, None	K1
DDR_DQ[8]	DRAM Data Bus [8]	I/O	DDR	PCR[260]	None, None	L1
DDR_DQ[7]	DRAM Data Bus [7]	I/O	DDR	PCR[261]	None, None	L4
DDR_DQ[6]	DRAM Data Bus [6]	I/O	DDR	PCR[262]	None, None	M4
DDR_DQ[5]	DRAM Data Bus [5]	I/O	DDR	PCR[263]	None, None	M1
DDR_DQ[4]	DRAM Data Bus [4]	I/O	DDR	PCR[264]	None, None	N4
DDR_DQ[3]	DRAM Data Bus [3]	I/O	DDR	PCR[265]	None, None	N1
DDR_DQ[2]	DRAM Data Bus [2]	I/O	DDR	PCR[266]	None, None	P4
DDR_DQ[1]	DRAM Data Bus [1]	I/O	DDR	PCR[267]	None, None	P1
DDR_DQ[0]	DRAM Data Bus [0]	I/O	DDR	PCR[268]	None, None	R1
DRAM Data Strobes						
DDR_DQS[3]	DRAM Data Strobe [3]	I/O	DDR	PCR[232]	None, None	B3
DDR_DQS[2]	DRAM Data Strobe [2]	I/O	DDR	PCR[231]	None, None	G2
DDR_DQS[1]	DRAM Data Strobe [1]	I/O	DDR	PCR[230]	None, None	K2
DDR_DQS[0]	DRAM Data Strobe [0]	I/O	DDR	PCR[229]	None, None	N2
DRAM Data Enables						
DDR_DM[3]	DRAM Data Enable [3]	Output	DDR	PCR[236]	Output, None	B4
DDR_DM[2]	DRAM Data Enable [2]	Output	DDR	PCR[235]	Output, None	G3
DDR_DM[1]	DRAM Data Enable [1]	Output	DDR	PCR[234]	Output, None	K3
DDR_DM[0]	DRAM Data Enable [0]	Output	DDR	PCR[233]	Output, None	P3
DRAM Address						

Table 6. DRAM interface pin summary (continued)

Port pin ¹	Function	I/O direction	Pad type	PCR	RESET config ²	Pin number
						416 TEPBGA
DDR_A[15]	DRAM address [15]	Output	DDR	PCR[217]	Output, None	B15
DDR_A[14]	DRAM address [14]	Output	DDR	PCR[216]	Output, None	D15
DDR_A[13]	DRAM address [13]	Output	DDR	PCR[215]	Output, None	D14
DDR_A[12]	DRAM address [12]	Output	DDR	PCR[214]	Output, None	A14
DDR_A[11]	DRAM address [11]	Output	DDR	PCR[213]	Output, None	D13
DDR_A[10]	DRAM address [10]	Output	DDR	PCR[212]	Output, None	C13
DDR_A[9]	DRAM address [9]	Output	DDR	PCR[211]	Output, None	B13
DDR_A[8]	DRAM address [8]	Output	DDR	PCR[210]	Output, None	A13
DDR_A[7]	DRAM address [7]	Output	DDR	PCR[209]	Output, None	B12
DDR_A[6]	DRAM address [6]	Output	DDR	PCR[208]	Output, None	A12
DDR_A[5]	DRAM address [5]	Output	DDR	PCR[207]	Output, None	D11
DDR_A[4]	DRAM address [4]	Output	DDR	PCR[206]	Output, None	A11
DDR_A[3]	DRAM address [3]	Output	DDR	PCR[205]	Output, None	D10
DDR_A[2]	DRAM address [2]	Output	DDR	PCR[204]	Output, None	C10
DDR_A[1]	DRAM address [1]	Output	DDR	PCR[203]	Output, None	B10
DDR_A[0]	DRAM address [0]	Output	DDR	PCR[202]	Output, None	A10
DRAM Bank Address						
DDR_BA[2]	DRAM Bank Address[2]	Output	DDR	PCR[220]	Output, None	A9
DDR_BA[1]	DRAM Bank Address[1]	Output	DDR	PCR[219]	Output, None	A8
DDR_BA[0]	DRAM Bank Address[0]	Output	DDR	PCR[218]	Output, None	A7
DRAM Control						

Table 6. DRAM interface pin summary (continued)

Port pin ¹	Function	I/O direction	Pad type	PCR	RESET config ²	Pin number
						416 TEPBGA
DDR_CAS	Column Address Strobe	Output	DDR	PCR[221]	Output, None	B6
DDR_RAS	Row Address Strobe	Output	DDR	PCR[227]	Output, None	B7
DDR_WEB	Write Enable	Output	DDR	PCR[228]	Output, None	B9
DDR_ODT	DRAM On-die termination	Output	DDR	PCR[226]	Output, Pull Down	D5
DDR_CLK	DRAM Clock	Output	DDR	PCR[225]	Output, None	C7
DDR_CLKB	DRAM Clock bar	Output	DDR	NA	Output, None	D7
DDR_CK	DRAM Clock Enable	Output	DDR	PCR[222]	Output, Pull Down	D8
DDR_CS	DRAM Chip Select	Output	DDR	PCR[223]	Output, None	D9
MVREF	DDR Reference Voltage	Input	—	NA	—	J4
MVTT	DRAM Termination Voltage	Input	—	NA	—	F2,J2,M2,R2

¹ These port pins are disabled and unpowered on packages where the DRAM interface is not bonded out.

² Reset configuration is given as I/O direction and pull direction (for example, "Input, pullup").

2.4.6 VIU muxing

The DCU3, DCULite and VIU2 modules share the same pins for input video. It is, however, possible to feed independent video streams to VIU2 and DCU3 (operating in narrow mode). [Figure 5](#) explains the pin sharing arrangement.

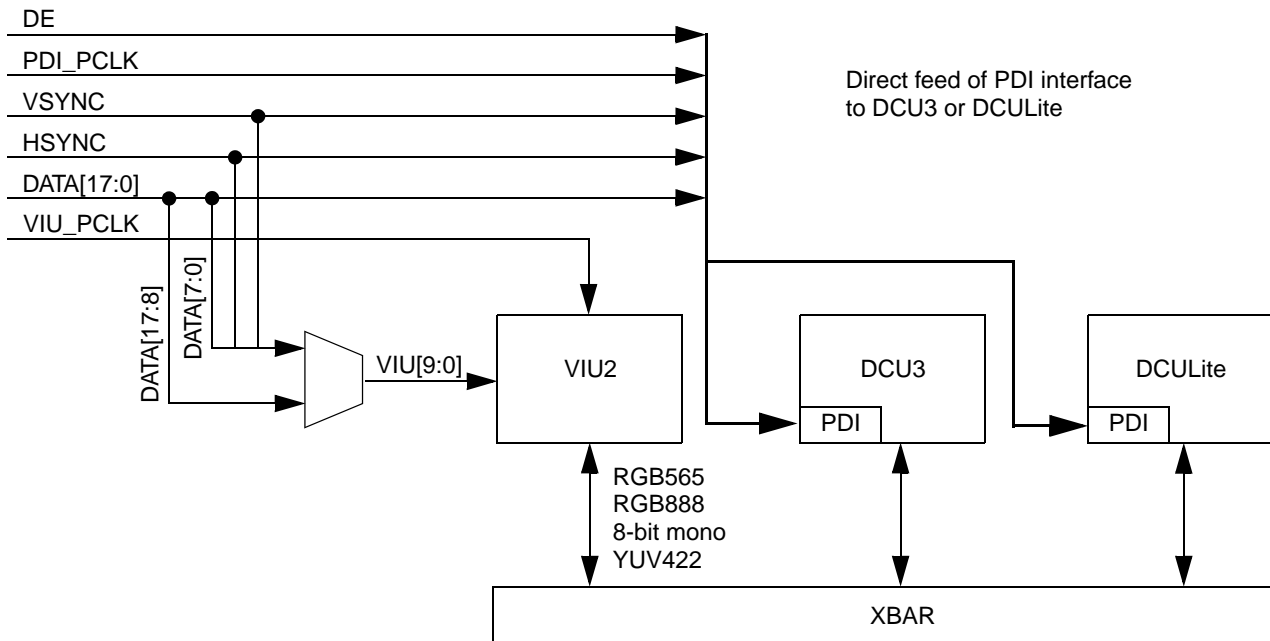

Figure 5. VIU2, DCU3, and DCULite pin sharing

VIU input data selection is done based on select bit (bit 0) of Miscellaneous control register (0xC3FE0340).

- VIU pix data: VIU[9:0]
- Select bit 1'b0: PDI[7:0], HSYNC, VSYNC
- Select bit 1'b1: PDI[17:8]

2.4.7 SGM muxing

The SGM shares pins between the PWM output signals and the I2S bus signals as shown in the “Port pin summary” table. When the PWM function is enabled in the SGM (SGMCTL[PWME]) the PWM (PWMO, PWMOA) signals are available. When the PWM function is disabled the I2S bus signals (I2S_DO, I2S_SCK) are available.

2.4.8 RSDS special function muxing

Ports PA[0:15], PG[0:7], PG[11] and PM[2] have the RSDS signalling option as a special function. The SIUL allocates pad control registers to these functions (PCR[270:282]), but because these pads share a common pin with the normal GPIO pins they do not operate in the same way as the normal GPIO ports. PG[11] in particular has a special configuration separate from the other pads.

The special-function pads are output-only, and the associated PCR[OBE] bit is controlled by the TCON_CTRL1 register (TCON_BYPASS and RSDS_MODE bits). However, the alternate function selection is taken from the associated normal GPIO pad. This allows selection of the DCU3 function as the alternate function of the pad and then the TCON module to select if the output style is TCON/RSDS or digital RGB format.

Therefore, when the TCON bypass is active (bypass disabled with or without RSDS active), it is important not to configure the normal GPIO ports for output operation with a non-DCU3 alternate function on ports PA[0:15] and PG[0:7].

For PG[11], the PCR[282] OBE bit is fully controlled by the TCON module and will become an output whenever the DCU3 alternate option is selected. Therefore, only select the DCU3 function on this pin when ready to configure it as a clock for a TFT panel.

2.4.9 Functional ports

The functional port pins are listed in [Table 7](#).

Table 7. Port pin summary

Port pin	PCR	Alternate function ¹	Function	Special function ²	Peripheral ³	I/O direction	Pad Type ⁴	RESET config ⁵	Pin number		
									176 LQFP	208 LQFP	416 TEPBGA
PORT A											
PA[0]	PCR[0]	Option 0 Option 1 Option 2 Option 3	GPIO[0] DCU_R0 SDA_1 eMIOS0[18]	RSDS0P	SIUL DCU3 I ² C_1 PWM/Timer	I/O	M / RSDS	None, none	116	139	K26
PA[1]	PCR[1]	Option 0 Option 1 Option 2 Option 3	GPIO[1] DCU_R1 SCL_1 eMIOS0[17]	RSDS0M	SIUL DCU3 I ² C_1 PWM/Timer	I/O	M / RSDS	None, none	117	140	K25
PA[2]	PCR[2]	Option 0 Option 1 Option 2 Option 3	GPIO[2] DCU_R2 — —	RSDS1P	SIUL DCU3 — —	I/O	M / RSDS	None, none	118	141	K23
PA[3]	PCR[3]	Option 0 Option 1 Option 2 Option 3	GPIO[3] DCU_R3 — —	RSDS1M	SIUL DCU3 — —	I/O	M / RSDS	None, none	119	142	J23
PA[4]	PCR[4]	Option 0 Option 1 Option 2 Option 3	GPIO[4] DCU_R4 — —	RSDS2P	SIUL DCU3 — —	I/O	M / RSDS	None, none	120	143	J26
PA[5]	PCR[5]	Option 0 Option 1 Option 2 Option 3	GPIO[5] DCU_R5 — —	RSDS2M	SIUL DCU3 — —	I/O	M / RSDS	None, none	121	144	J25
PA[6]	PCR[6]	Option 0 Option 1 Option 2 Option 3	GPIO[6] DCU_R6 — —	RSDS3P	SIUL DCU3 — —	I/O	M / RSDS	None, none	124	148	H26

Table 7. Port pin summary (continued)

Port pin	PCR	Alternate function ¹	Function	Special function ²	Peripheral ³	I/O direction	Pad Type ⁴	RESET config ⁵	Pin number		
									176 LQFP	208 LQFP	416 TEPBGA
PA[7]	PCR[7]	Option 0 Option 1 Option 2 Option 3	GPIO[7] DCU_R7 — —	RSDS3M	SIUL DCU3 — —	I/O	M / RSDS	None, none	125	149	G26
PA[8]	PCR[8]	Option 0 Option 1 Option 2 Option 3	GPIO[8] DCU_G0 SCL_2 eMIOS0[20]	RSDS4P	SIUL DCU3 I ² C_2 PWM/Timer	I/O	M / RSDS	None, none	126	150	G25
PA[9]	PCR[9]	Option 0 Option 1 Option 2 Option 3	GPIO[9] DCU_G1 SDA_2 eMIOS0[19]	RSDS4M	SIUL DCU3 I ² C_2 PWM/Timer	I/O	M / RSDS	None, none	127	151	G24
PA[10]	PCR[10]	Option 0 Option 1 Option 2 Option 3	GPIO[10] DCU_G2 — —	RSDS5P	SIUL DCU3 — —	I/O	M / RSDS	None, none	128	152	H23
PA[11]	PCR[11]	Option 0 Option 1 Option 2 Option 3	GPIO[11] DCU_G3 — —	RSDS5M	SIUL DCU3 — —	I/O	M / RSDS	None, none	129	153	G23
PA[12]	PCR[12]	Option 0 Option 1 Option 2 Option 3	GPIO[12] DCU_G4 — —	RSDS6P	SIUL DCU3 — —	I/O	M / RSDS	None, none	130	154	F26
PA[13]	PCR[13]	Option 0 Option 1 Option 2 Option 3	GPIO[13] DCU_G5 — —	RSDS6M	SIUL DCU3 — —	I/O	M / RSDS	None, none	131	155	F25
PA[14]	PCR[14]	Option 0 Option 1 Option 2 Option 3	GPIO[14] DCU_G6 — —	RSDS7P	SIUL DCU3 — —	I/O	M / RSDS	None, none	134	158	F24

Table 7. Port pin summary (continued)

Port pin	PCR	Alternate function ¹	Function	Special function ²	Peripheral ³	I/O direction	Pad Type ⁴	RESET config ⁵	Pin number		
									176 LQFP	208 LQFP	416 TEPBGA
PA[15]	PCR[15]	Option 0 Option 1 Option 2 Option 3	GPIO[15] DCU_G7 — —	RSDS7M	SIUL DCU3 — —	I/O	M / RSDS	None, none	135	159	F23
PORT B											
PB[0]	PCR[16]	Option 0 Option 1 Option 2 Option 3	GPIO[16] CANTX_0 TXD_0 —	—	SIUL FlexCAN_0 LINFlex_0 —	I/O	S	None, none	13	13	W4
PB[1]	PCR[17]	Option 0 Option 1 Option 2 Option 3	GPIO[17] CANRX_0 RXD_0 —	—	SIUL FlexCAN_0 LINFlex_0 —	I/O	S	None, none	12	12	V1
PB[2]	PCR[18]	Option 0 Option 1 Option 2 Option 3	GPIO[18] TXD_0 — —	—	SIUL LINFlex_0 — —	I/O	S	None, none	153	183	D21
PB[3]	PCR[19]	Option 0 Option 1 Option 2 Option 3	GPIO[19] RXD_0 — —	—	SIUL LINFlex_0 — —	I/O	S	None, none	152	182	A22
PB[4]	PCR[20]	Option 0 Option 1 Option 2 Option 3	GPIO[20] SCK_1 MA0 —	—	SIUL DSPI_1 ADC —	I/O	S	None, none	62	74	AF15
PB[5]	PCR[21]	Option 0 Option 1 Option 2 Option 3	GPIO[21] SOUT_1 MA1 FABM	—	SIUL DSPI_1 ADC Control	I/O	S	Input, pull- down	63	75	AC16
PB[6]	PCR[22]	Option 0 Option 1 Option 2 Option 3	GPIO[22] SIN_1 MA2 ABS[0]	—	SIUL DSPI_1 ADC Control	I/O	S	Input, pull- up	64	76	AF16

Table 7. Port pin summary (continued)

Port pin	PCR	Alternate function ¹	Function	Special function ²	Peripheral ³	I/O direction	Pad Type ⁴	RESET config ⁵	Pin number		
									176 LQFP	208 LQFP	416 TEPBGA
PB[7]	PCR[23]	Option 0 Option 1 Option 2 Option 3	GPIO[23] SIN_0 eMIOS1[20] I2S_SCK/PWMOA	—	SIUL DSPI_0 PWM/Timer SGM	I/O	S	None, none	55	67	AC14
PB[8]	PCR[24]	Option 0 Option 1 Option 2 Option 3	GPIO[24] SOUT_0 eMIOS1[19] I2S_DO/PWMO	—	SIUL DSPI_0 PWM/Timer SGM	I/O	S	None, none	54	66	AF13
PB[9]	PCR[25]	Option 0 Option 1 Option 2 Option 3	GPIO[25] SCK_0 eMIOS1[18] I2S_FS	—	SIUL DSPI_0 PWM/Timer SGM	I/O	M	None, none	53	65	AC13
PB[10]	PCR[26]	Option 0 Option 1 Option 2 Option 3	GPIO[26] CANRX_1 I2S_DO/PWMO —	—	SIUL FlexCAN_1 SGM —	I/O	S	None, none	14	14	W2
PB[11]	PCR[27]	Option 0 Option 1 Option 2 Option 3	GPIO[27] CANTX_1 SGM_MCLK —	—	SIUL FlexCAN_1 SGM —	I/O	S	None, none	15	15	Y4
PB[12]	PCR[28]	Option 0 Option 1 Option 2 Option 3	GPIO[28] RXD_1 eMIOS1[10] CS2_0	—	SIUL LINFlex_1 PWM/Timer DSPI_0	I/O	S	None, none	46	54	AF7
PB[13]	PCR[29]	Option 0 Option 1 Option 2 Option 3	GPIO[29] TXD_1 eMIOS1[11] CS1_0	—	SIUL LINFlex_1 PWM/Timer DSPI_0	I/O	S	None, none	47	55	AC8
PB[14]	—	—	Reserved	—	—	—	—	—	—	—	—
PB[15]	—	—	Reserved	—	—	—	—	—	—	—	—
PORT C											

Table 7. Port pin summary (continued)

Port pin	PCR	Alternate function ¹	Function	Special function ²	Peripheral ³	I/O direction	Pad Type ⁴	RESET config ⁵	Pin number		
									176 LQFP	208 LQFP	416 TEPBGA
PC[0]	PCR[30]	Option 0 Option 1 Option 2 Option 3	GPIO[30] — — —	ANS[0]	SIUL — — —	I/O	J	None, none	88	104	AC21
PC[1]	PCR[31]	Option 0 Option 1 Option 2 Option 3	GPIO[31] — — —	ANS[1]	SIUL — — —	I/O	J	None, none	87	103	AC25
PC[2]	PCR[32]	Option 0 Option 1 Option 2 Option 3	GPIO[32] — — —	ANS[2]	SIUL — — —	I/O	J	None, none	86	102	AC26
PC[3]	PCR[33]	Option 0 Option 1 Option 2 Option 3	GPIO[33] — — —	ANS[3]	SIUL — — —	I/O	J	None, none	85	101	AC24
PC[4]	PCR[34]	Option 0 Option 1 Option 2 Option 3	GPIO[34] — — —	ANS[4]	SIUL — — —	I/O	J	None, none	84	100	AD24
PC[5]	PCR[35]	Option 0 Option 1 Option 2 Option 3	GPIO[35] — — —	ANS[5]	SIUL — — —	I/O	J	None, none	83	99	AD26
PC[6]	PCR[36]	Option 0 Option 1 Option 2 Option 3	GPIO[36] — — —	ANS[6]	SIUL — — —	I/O	J	None, none	82	98	AD21
PC[7]	PCR[37]	Option 0 Option 1 Option 2 Option 3	GPIO[37] — — —	ANS[7]	SIUL — — —	I/O	J	None, none	81	97	AD25

Table 7. Port pin summary (continued)

Port pin	PCR	Alternate function ¹	Function	Special function ²	Peripheral ³	I/O direction	Pad Type ⁴	RESET config ⁵	Pin number		
									176 LQFP	208 LQFP	416 TEPBGA
PC[8]	PCR[38]	Option 0 Option 1 Option 2 Option 3	GPIO[38] — — —	ANS[8]	SIUL — — —	I/O	J	None, none	76	92	AE26
PC[9]	PCR[39]	Option 0 Option 1 Option 2 Option 3	GPIO[39] — — —	ANS[9]	SIUL — — —	I/O	J	None, none	75	91	AE25
PC[10]	PCR[40]	Option 0 Option 1 Option 2 Option 3	GPIO[40] — I2S_DO/PWMO —	ANS[10]	SIUL — SGM —	I/O	J	None, none	74	90	AE23
PC[11]	PCR[41]	Option 0 Option 1 Option 2 Option 3	GPIO[41] — MA0 CS2_1	ANS[11]	SIUL — ADC DSPI_1	I/O	J	None, None	73	89	AE24
PC[12]	PCR[42]	Option 0 Option 1 Option 2 Option 3	GPIO[42] — MA1 CS1_1	ANS[12]	SIUL — ADC DSPI_1	I/O	J	None, None	72	88	AF26
PC[13]	PCR[43]	Option 0 Option 1 Option 2 Option 3	GPIO[43] — MA2 CS0_1	ANS[13]	SIUL — ADC DSPI_1	I/O	J	None, None	71	87	AF25
PC[14]	PCR[44]	Option 0 Option 1 Option 2 Option 3	GPIO[44] — — —	ANS[14] EXTAL32	SIUL — — —	I/O	J	None, None	70	86	AF24
PC[15]	PCR[45]	Option 0 Option 1 Option 2 Option 3	GPIO[45] — — —	ANS[15] XTAL32	SIUL — — —	I/O	J	None, None	69	85	AF23
PORT D											

Table 7. Port pin summary (continued)

Port pin	PCR	Alternate function ¹	Function	Special function ²	Peripheral ³	I/O direction	Pad Type ⁴	RESET config ⁵	Pin number		
									176 LQFP	208 LQFP	416 TEPBGA
PD[0]	PCR[46]	Option 0 Option 1 Option 2 Option 3	GPIO[46] M0C0M SSD0_0 eMIOS1[8]	—	SIUL SMD SSD PWM/Timer	I/O	SMD	None, None	90	106	AB26
PD[1]	PCR[47]	Option 0 Option 1 Option 2 Option 3	GPIO[47] M0C0P SSD0_1 eMIOS1[16]	—	SIUL SMC SSD PWM/Timer	I/O	SMD	None, None	91	107	AB25
PD[2]	PCR[48]	Option 0 Option 1 Option 2 Option 3	GPIO[48] M0C1M SSD0_2 eMIOS1[23]	—	SIUL SMC SSD PWM/Timer	I/O	SMD	None, None	92	108	AB24
PD[3]	PCR[49]	Option 0 Option 1 Option 2 Option 3	GPIO[49] M0C1P SSD0_3 eMIOS0[9]	—	SIUL SMC SSD PWM/Timer	I/O	SMD	None, None	93	109	AB23
PD[4]	PCR[50]	Option 0 Option 1 Option 2 Option 3	GPIO[50] M1C0M SSD1_0 eMIOS0[8]	—	SIUL SMC SSD PWM/Timer	I/O	SMD	None, None	96	112	AA26
PD[5]	PCR[51]	Option 0 Option 1 Option 2 Option 3	GPIO[51] M1C0P SSD1_1 eMIOS0[16]	—	SIUL SMC SSD PWM/Timer	I/O	SMD	None, None	97	113	AA23
PD[6]	PCR[52]	Option 0 Option 1 Option 2 Option 3	GPIO[52] M1C1M SSD1_2 eMIOS0[23]	—	SIUL SMC SSD PWM/Timer	I/O	SMD	None, None	98	114	Y26
PD[7]	PCR[53]	Option 0 Option 1 Option 2 Option 3	GPIO[53] M1C1P SSD1_3 —	—	SIUL SMC SSD —	I/O	SMD	None, None	99	115	Y25

Table 7. Port pin summary (continued)

Port pin	PCR	Alternate function ¹	Function	Special function ²	Peripheral ³	I/O direction	Pad Type ⁴	RESET config ⁵	Pin number		
									176 LQFP	208 LQFP	416 TEPBGA
PD[8]	PCR[54]	Option 0 Option 1 Option 2 Option 3	GPIO[54] M2C0M SSD2_0 —	—	SIUL SMC SSD —	I/O	SMD	None, None	100	116	Y24
PD[9]	PCR[55]	Option 0 Option 1 Option 2 Option 3	GPIO[55] M2C0P SSD2_1 eMIOS0[9]	—	SIUL SMC SSD PWM/Timer	I/O	SMD	None, None	101	117	Y23
PD[10]	PCR[56]	Option 0 Option 1 Option 2 Option 3	GPIO[56] M2C1M SSD2_2 eMIOS0[10]	—	SIUL SMC SSD PWM/Timer	I/O	SMD	None, None	102	118	W26
PD[11]	PCR[57]	Option 0 Option 1 Option 2 Option 3	GPIO[57] M2C1P SSD2_3 eMIOS0[11]	—	SIUL SMC SSD PWM/Timer	I/O	SMD	None, None	103	119	W23
PD[12]	PCR[58]	Option 0 Option 1 Option 2 Option 3	GPIO[58] M3C0M SSD3_0 eMIOS0[12]	—	SIUL SMC SSD PWM/Timer	I/O	SMD	None, None	106	122	V26
PD[13]	PCR[59]	Option 0 Option 1 Option 2 Option 3	GPIO[59] M3C0P SSD3_1 eMIOS0[13]	—	SIUL SMC SSD PWM/Timer	I/O	SMD	None, None	107	123	V25
PD[14]	PCR[60]	Option 0 Option 1 Option 2 Option 3	GPIO[60] M3C1M SSD3_2 eMIOS0[14]	—	SIUL SMC SSD PWM/Timer	I/O	SMD	None, None	108	124	V24
PD[15]	PCR[61]	Option 0 Option 1 Option 2 Option 3	GPIO[61] M3C1P SSD3_3 eMIOS0[15]	—	SIUL SMC SSD PWM/Timer	I/O	SMD	None, None	109	125	V23
PORT E											

Table 7. Port pin summary (continued)

Port pin	PCR	Alternate function ¹	Function	Special function ²	Peripheral ³	I/O direction	Pad Type ⁴	RESET config ⁵	Pin number		
									176 LQFP	208 LQFP	416 TEPBGA
PE[0]	PCR[62]	Option 0 Option 1 Option 2 Option 3	GPIO[62] M4C0M SSD4_0 —	—	SIUL SMC SSD —	I/O	SMD	None, None	—	126	U26
PE[1]	PCR[63]	Option 0 Option 1 Option 2 Option 3	GPIO[63] M4C0P SSD4_1 —	—	SIUL SMC SSD —	I/O	SMD	None, None	—	127	U23
PE[2]	PCR[64]	Option 0 Option 1 Option 2 Option 3	GPIO[64] M4C1M SSD4_2 —	—	SIUL SMC SSD —	I/O	SMD	None, None	—	128	T26
PE[3]	PCR[65]	Option 0 Option 1 Option 2 Option 3	GPIO[65] M4C1P SSD4_3 —	—	SIUL SMC SSD —	I/O	SMD	None, None	—	129	T25
PE[4]	PCR[66]	Option 0 Option 1 Option 2 Option 3	GPIO[66] M5C0M SSD5_0 —	—	SIUL SMC SSD —	I/O	SMD	None, None	—	132	T24
PE[5]	PCR[67]	Option 0 Option 1 Option 2 Option 3	GPIO[67] M5C0P SSD5_1 —	—	SIUL SMC SSD —	I/O	SMD	None, None	—	133	T23
PE[6]	PCR[68]	Option 0 Option 1 Option 2 Option 3	GPIO[68] M5C1M SSD5_2 —	—	SIUL SMC SSD —	I/O	SMD	None, None	—	134	R24
PE[7]	PCR[69]	Option 0 Option 1 Option 2 Option 3	GPIO[69] M5C1P SSD5_3 —	—	SIUL SMC SSD —	I/O	SMD	None, None	—	135	R23
PORT F											

Table 7. Port pin summary (continued)

Port pin	PCR	Alternate function ¹	Function	Special function ²	Peripheral ³	I/O direction	Pad Type ⁴	RESET config ⁵	Pin number		
									176 LQFP	208 LQFP	416 TEPBGA
PF[0]	PCR[70]	Option 0 Option 1 Option 2 Option 3	GPIO[70] eMIOS1[19] EVTO DCULITE_B2	—	SIUL PWM/Timer NEXUS DCULite	I/O	M	None, None	157	189	C20
PF[1]	PCR[71]	Option 0 Option 1 Option 2 Option 3	GPIO[71] eMIOS1[20] MSEO DCULITE_B3	—	SIUL PWM/Timer NEXUS DCULite	I/O	M	None, None	158	190	B20
PF[2]	PCR[72]	Option 0 Option 1 Option 2 Option 3	GPIO[72] NMI — —	—	SIUL NMI — —	I/O	S	None, None	45	53	AC7
PF[3]	PCR[73]	Option 0 Option 1 Option 2 Option 3	GPIO[73] eMIOS1[21] MSEO DCULITE_B4	—	SIUL PWM/Timer NEXUS DCULite	I/O	M	None, None	159	191	A20
PF[4]	PCR[74]	Option 0 Option 1 Option 2 Option 3	GPIO[74] eMIOS1[14] SDA_1 DCULITE_B5	—	SIUL PWM/Timer I ² C_1 DCULite	I/O	M	None, None	160	192	D19
PF[5]	PCR[75]	Option 0 Option 1 Option 2 Option 3	GPIO[75] QUADSPI_IO1_B eMIOS1[15] VIU8_PDI16	—	SIUL QuadSPI PWM/Timer VIU2/PDI	I/O	M	None, None	161	193	A19
PF[6]	PCR[76]	Option 0 Option 1 Option 2 Option 3	GPIO[76] QUADSPI_IO0_B eMIOS1[16] VIU9_PDI17	—	SIUL QuadSPI PWM/Timer VIU2/PDI	I/O	M	None, None	162	194	D18
PF[7]	PCR[77]	Option 0 Option 1 Option 2 Option 3	GPIO[77] eMIOS1[15] SCL_1 DCULITE_B6	—	SIUL PWM/Timer I ² C_1 DCULite	I/O	M	None, None	163	195	C18

Table 7. Port pin summary (continued)

Port pin	PCR	Alternate function ¹	Function	Special function ²	Peripheral ³	I/O direction	Pad Type ⁴	RESET config ⁵	Pin number		
									176 LQFP	208 LQFP	416 TEPBGA
PF[8]	PCR[78]	Option 0 Option 1 Option 2 Option 3	GPIO[78] SDA_0 CS2_1 RXD_1	—	SIUL I ² C_0 DSPI_1 LINFlex_1	I/O	S	None, None	164	196	A18
PF[9]	PCR[79]	Option 0 Option 1 Option 2 Option 3	GPIO[79] SCL_0 CS1_1 TXD_1	—	SIUL I ² C_0 DSPI_1 LINFlex_1	I/O	S	None, None	165	197	D17
PF[10]	PCR[80]	Option 0 Option 1 Option 2 Option 3	GPIO[80] QUADSPI_PCS_A — EVTI	—	SIUL QuadSPI — NEXUS	I/O	M	None, None	169	201	A17
PF[11]	PCR[81]	Option 0 Option 1 Option 2 Option 3	GPIO[81] QUADSPI_IO2_A — MDO0	—	SIUL QuadSPI — NEXUS	I/O	M	None, None	170	202	D16
PF[12]	PCR[82]	Option 0 Option 1 Option 2 Option 3	GPIO[82] QUADSPI_IO3_A — MDO1	—	SIUL QuadSPI — NEXUS	I/O	M	None, None	171	203	C16
PF[13]	PCR[83]	Option 0 Option 1 Option 2 Option 3	GPIO[83] QUADSPI_IO0_A — MDO2	—	SIUL QuadSPI — NEXUS	I/O	M	None, None	172	204	B16
PF[14]	PCR[84]	Option 0 Option 1 Option 2 Option 3	GPIO[84] QUADSPI_IO1_A — MDO3	—	SIUL QuadSPI — NEXUS	I/O	M	None, None	173	205	A16
PF[15]	PCR[85]	Option 0 Option 1 Option 2 Option 3	GPIO[85] QUADSPI_CLK_A CLKOUT MCKO	—	SIUL QuadSPI Control NEXUS	I/O	F	None, None	174	206	B18
PORT G											

Table 7. Port pin summary (continued)

Port pin	PCR	Alternate function ¹	Function	Special function ²	Peripheral ³	I/O direction	Pad Type ⁴	RESET config ⁵	Pin number		
									176 LQFP	208 LQFP	416 TEPBGA
PG[0]	PCR[86]	Option 0 Option 1 Option 2 Option 3	GPIO[86] DCU_B0 SCL_3 eMIOS0[21]	RSDS8P	SIUL DCU3 I ² C_3 PWM/Timer	I/O	M	None, None	136	160	E26
PG[1]	PCR[87]	Option 0 Option 1 Option 2 Option 3	GPIO[87] DCU_B1 SDA_3 eMIOS0[22]	RSDS8M	SIUL DCU3 I ² C_3 PWM/Timer	I/O	M	None, None	137	161	D26
PG[2]	PCR[88]	Option 0 Option 1 Option 2 Option 3	GPIO[88] DCU_B2 — —	RSDS9P	SIUL DCU3 — —	I/O	M	None, None	141	166	D25
PG[3]	PCR[89]	Option 0 Option 1 Option 2 Option 3	GPIO[89] DCU_B3 — —	RSDS9M	SIUL DCU3 — —	I/O	M	None, None	142	167	C25
PG[4]	PCR[90]	Option 0 Option 1 Option 2 Option 3	GPIO[90] DCU_B4 — —	RSDS10P	SIUL DCU3 — —	I/O	M	None, None	143	168	C26
PG[5]	PCR[91]	Option 0 Option 1 Option 2 Option 3	GPIO[91] DCU_B5 — —	RSDS10M	SIUL DCU3 — —	I/O	M	None, None	144	169	B26
PG[6]	PCR[92]	Option 0 Option 1 Option 2 Option 3	GPIO[92] DCU_B6 — —	RSDS11P	SIUL DCU3 — —	I/O	M	None, None	145	170	A26
PG[7]	PCR[93]	Option 0 Option 1 Option 2 Option 3	GPIO[93] DCU_B7 — —	RSDS11M	SIUL DCU3 — —	I/O	M	None, None	146	171	A25

Table 7. Port pin summary (continued)

Port pin	PCR	Alternate function ¹	Function	Special function ²	Peripheral ³	I/O direction	Pad Type ⁴	RESET config ⁵	Pin number		
									176 LQFP	208 LQFP	416 TEPBGA
PG[8]	PCR[94]	Option 0 Option 1 Option 2 Option 3	GPIO[94] DCU_VSYNC — —	—	SIUL DCU3 — —	I/O	M	None, None	1	1	T4
PG[9]	PCR[95]	Option 0 Option 1 Option 2 Option 3	GPIO[95] DCU_HSYNC — —	—	SIUL DCU3 — —	I/O	M	None, None	2	2	T2
PG[10]	PCR[96]	Option 0 Option 1 Option 2 Option 3	GPIO[96] DCU_DE — —	—	SIUL DCU3 — —	I/O	M	None, None	3	3	T1
PG[11]	PCR[97]	Option 0 Option 1 Option 2 Option 3	GPIO[97] DCU_PCLK — —	RSDSCLKP	SIUL DCU3 — —	I/O	F	None, None	147	172	E23
PG[12]	PCR[98]	Option 0 Option 1 Option 2 Option 3	GPIO[98] CS0_1 PDI_DE DCULITE_B7	—	SIUL DSPI_1 PDI DCULite	I/O	M	None, None	168	200	A15
PG[13]	—	—	Reserved	—	—	—	—	—	—	—	—
PG[14]	—	—	Reserved	—	—	—	—	—	—	—	—
PG[15]	—	—	Reserved	—	—	—	—	—	—	—	—
PORT H											
PH[0] ⁶	PCR[99]	Option 0 Option 1 Option 2 Option 3	GPIO[99] TCK — —	—	SIUL JTAG — —	I/O	S	Input, Pull Up	41	49	AC6
PH[1] ⁶	PCR[100]	Option 0 Option 1 Option 2 Option 3	GPIO[100] TDI — —	—	SIUL JTAG — —	I/O	S	Input, Pull Up	42	50	AD6

Table 7. Port pin summary (continued)

Port pin	PCR	Alternate function ¹	Function	Special function ²	Peripheral ³	I/O direction	Pad Type ⁴	RESET config ⁵	Pin number		
									176 LQFP	208 LQFP	416 TEPBGA
PH[2] ⁶	PCR[101]	Option 0 Option 1 Option 2 Option 3	GPIO[101] TDO — —	—	SIUL JTAG — —	I/O	M	Output, None	43	51	AE6
PH[3] ⁶	PCR[102]	Option 0 Option 1 Option 2 Option 3	GPIO[102] TMS — —	—	SIUL JTAG — —	I/O	S	Input, Pull Up	44	52	AF6
PH[4]	PCR[103]	Option 0 Option 1 Option 2 Option 3	GPIO[103] CS0_0 eMIOS1[21] DCULITE_G6	—	SIUL DSPL_0 PWM/Timer DCULite	I/O	M	None, None	61	73	AE15
PH[5]	PCR[104]	Option 0 Option 1 Option 2 Option 3	GPIO[104] VIU7_PDI15 I2S_FS eMIOS1[8]	—	SIUL VIU2/PDI SGM PWM/Timer	I/O	S	None, None	38	—	—
PH[6]	—	—	Reserved	—	—	—	—	—	—	—	—
PH[7]	—	—	Reserved	—	—	—	—	—	—	—	—
PH[8]	—	—	Reserved	—	—	—	—	—	—	—	—
PH[9]	—	—	Reserved	—	—	—	—	—	—	—	—
PH[10]	—	—	Reserved	—	—	—	—	—	—	—	—
PH[11]	—	—	Reserved	—	—	—	—	—	—	—	—
PH[12]	—	—	Reserved	—	—	—	—	—	—	—	—
PH[13]	—	—	Reserved	—	—	—	—	—	—	—	—
PH[14]	—	—	Reserved	—	—	—	—	—	—	—	—
PH[15]	—	—	Reserved	—	—	—	—	—	—	—	—
PORT J											
PJ[0]	PCR[105]	Option 0 Option 1 Option 2 Option 3	GPIO[105] DCULITE_B6 — I2S_DO / PWMO	—	SIUL DCULite — SGM	I/O	M	None, None	—	—	L26

Table 7. Port pin summary (continued)

Port pin	PCR	Alternate function ¹	Function	Special function ²	Peripheral ³	I/O direction	Pad Type ⁴	RESET config ⁵	Pin number		
									176 LQFP	208 LQFP	416 TEPBGA
PJ[1]	PCR[106]	Option 0 Option 1 Option 2 Option 3	GPIO[106] VIU1_PDI_HSYNC eMIOS1[9] eMIOS0[8]	—	SIUL VIU2/PDI PWM/Timer PWM/Timer	I/O	S	None, None	4	4	U4
PJ[2]	PCR[107]	Option 0 Option 1 Option 2 Option 3	GPIO[107] VIU0_PDI_VSYNC eMIOS1[14] eMIOS0[9]	—	SIUL VIU2/PDI PWM/Timer PWM/Timer	I/O	S	None, None	5	5	U3
PJ[3]	PCR[108]	Option 0 Option 1 Option 2 Option 3	GPIO[108] VIU_PCLK eMIOS0[22] PDI_DE	—	SIUL VIU2 PWM/Timer PDI	I/O	S	None, None	60	72	AD15
PJ[4]	PCR[109]	Option 0 Option 1 Option 2 Option 3	GPIO[109] VIU2_PDI0 eMIOS0[21] eMIOS0[23]	—	SIUL VIU2/PDI PWM/Timer PWM/Timer	I/O	S	None, None	56	68	AD14
PJ[5]	PCR[110]	Option 0 Option 1 Option 2 Option 3	GPIO[110] VIU3_PDI1 eMIOS0[20] eMIOS0[16]	—	SIUL VIU2/PDI PWM/Timer PWM/Timer	I/O	M	None, None	57	69	AE14
PJ[6]	PCR[111]	Option 0 Option 1 Option 2 Option 3	GPIO[111] VIU4_PDI2 eMIOS0[19] eMIOS0[15]	—	SIUL VIU2/PDI PWM/Timer PWM/Timer	I/O	S	None, None	58	70	AF14
PJ[7]	PCR[112]	Option 0 Option 1 Option 2 Option 3	GPIO[112] VIU5_PDI3 eMIOS0[18] eMIOS0[14]	—	SIUL VIU2/PDI PWM/Timer PWM/Timer	I/O	S	None, None	59	71	AC15
PJ[8]	PCR[113]	Option 0 Option 1 Option 2 Option 3	GPIO[113] VIU6_PDI4 eMIOS0[17] eMIOS0[13]	—	SIUL VIU2/PDI PWM/Timer PWM/Timer	I/O	S	None, None	8	8	U2

Table 7. Port pin summary (continued)

Port pin	PCR	Alternate function ¹	Function	Special function ²	Peripheral ³	I/O direction	Pad Type ⁴	RESET config ⁵	Pin number		
									176 LQFP	208 LQFP	416 TEPBGA
PJ[9]	PCR[114]	Option 0 Option 1 Option 2 Option 3	GPIO[114] VIU7_PDI5 eMIOS1[22] eMIOS0[12]	—	SIUL VIU2/PDI PWM/Timer PWM/Timer	I/O	S	None, None	9	9	U1
PJ[10]	PCR[115]	Option 0 Option 1 Option 2 Option 3	GPIO[115] VIU8_PDI6 eMIOS1[17] eMIOS0[11]	—	SIUL VIU2/PDI PWM/Timer PWM/Timer	I/O	S	None, None	10	10	V4
PJ[11]	PCR[116]	Option 0 Option 1 Option 2 Option 3	GPIO[116] VIU9_PDI7 eMIOS1[15] eMIOS0[10]	—	SIUL VIU2/PDI PWM/Timer PWM/Timer	I/O	S	None, None	11	11	V3
PJ[12]	PCR[117]	Option 0 Option 1 Option 2 Option 3	GPIO[117] DCU_TAG — DCULITE_G6	—	SIUL DCU3 — DCULite	I/O	M	None, None	148	178	A23
PJ[13]	PCR[118]	Option 0 Option 1 Option 2 Option 3	GPIO[118] QUADSPI_PCS_B eMIOS1[8] VIU5_PDI13	—	SIUL QuadSPI PWM/Timer VIU2/PDI	I/O	M	None, None	149	179	D22
PJ[14]	PCR[119]	Option 0 Option 1 Option 2 Option 3	GPIO[119] QUADSPI_CLK_B eMIOS1[17] PDI_PCLK	—	SIUL QuadSPI PWM/Timer PDI	I/O	F	None, None	150	180	C22
PJ[15]	PCR[120]	Option 0 Option 1 Option 2 Option 3	GPIO[120] QUADSPI_IO3_B eMIOS1[9] VIU6_PDI14	—	SIUL QuadSPI PWM/Timer VIU2/PDI	I/O	M	None, None	151	181	B22
PORT K											
PK[0]	PCR[121]	Option 0 Option 1 Option 2 Option 3	GPIO[121] eMIOS1[18] — DCULITE_G7	—	SIUL PWM/Timer — DCULite	I/O	M	None, None	155	187	A21

Table 7. Port pin summary (continued)

Port pin	PCR	Alternate function ¹	Function	Special function ²	Peripheral ³	I/O direction	Pad Type ⁴	RESET config ⁵	Pin number		
									176 LQFP	208 LQFP	416 TEPBGA
PK[1]	PCR[122]	Option 0 Option 1 Option 2 Option 3	GPIO[122] QUADSPI_IO2_B eMIOS1[14] VIU7_PDI15	—	SIUL QuadSPI PWM/Timer VIU2/PDI	I/O	M	None, None	156	188	D20
PK[2]	PCR[123]	Option 0 Option 1 Option 2 Option 3	GPIO[123] VIU0_PDI8 eMIOS1[10] DCULITE_TAG	—	SIUL VIU2/PDI PWM/Timer DCULite	I/O	M	None, None	31	39	AE3
PK[3]	PCR[124]	Option 0 Option 1 Option 2 Option 3	GPIO[124] VIU1_PDI9 eMIOS1[11] DCULITE_DE	—	SIUL VIU2/PDI PWM/Timer DCULite	I/O	M	None, None	32	40	AF3
PK[4]	PCR[125]	Option 0 Option 1 Option 2 Option 3	GPIO[125] VIU2_PDI10 eMIOS1[12] DCULITE_HSYNC	—	SIUL VIU2/PDI PWM/Timer DCULite	I/O	M	None, None	33	41	AC4
PK[5]	PCR[126]	Option 0 Option 1 Option 2 Option 3	GPIO[126] VIU3_PDI11 eMIOS1[13] DCULITE_VSYNC	—	SIUL VIU2/PDI PWM/Timer DCULite	I/O	M	None, None	34	42	AF4
PK[6]	PCR[127]	Option 0 Option 1 Option 2 Option 3	GPIO[127] VIU4_PDI12 eMIOS1[9] DCULITE_PCLK	—	SIUL VIU2/PDI PWM/Timer DCULite	I/O	F	None, None	35	43	AC5
PK[7]	PCR[128]	Option 0 Option 1 Option 2 Option 3	GPIO[128] RXD_2 DCULITE_R2 TCON[8]	—	SIUL LINFlex_2 DCULite TCON	I/O	M	None, None	—	44	AD5
PK[8]	PCR[129]	Option 0 Option 1 Option 2 Option 3	GPIO[129] TXD_2 DCULITE_R3 TCON[9]	—	SIUL LINFlex_2 DCULite TCON	I/O	M	None, None	—	45	AE5

Table 7. Port pin summary (continued)

Port pin	PCR	Alternate function ¹	Function	Special function ²	Peripheral ³	I/O direction	Pad Type ⁴	RESET config ⁵	Pin number		
									176 LQFP	208 LQFP	416 TEPBGA
PK[9]	PCR[130]	Option 0 Option 1 Option 2 Option 3	GPIO[130] I2S_DO / PWMO DCULITE_R4 TCON[10]	—	SIUL SGM DCULite TCON	I/O	M	None, None	—	46	AF5
PK[10]	PCR[131]	Option 0 Option 1 Option 2 Option 3	GPIO[131] SDA_1 eMIOS1[12] DCULITE_TAG	—	SIUL I ² C_1 PWM/Timer DCULite	I/O	S	None, None	51	59	AF8
PK[11]	PCR[132]	Option 0 Option 1 Option 2 Option 3	GPIO[132] SCL_1 eMIOS1[13] DCU_TAG / TCON[3]	—	SIUL I ² C_1 PWM/Timer DCU3 / TCON	I/O	S	None, None	52	60	AC9
PK[12]	—	—	Reserved	—	—	—	—	—	—	—	—
PK[13]	—	—	Reserved	—	—	—	—	—	—	—	—
PK[14]	—	—	Reserved	—	—	—	—	—	—	—	—
PK[15]	—	—	Reserved	—	—	—	—	—	—	—	—
PORT L											
PL[0]	PCR[133]	Option 0 Option 1 Option 2 Option 3	GPIO[133] — CANRX_1 —	ANS[19]	SIUL — FlexCAN_1 —	I/O	M / ANALO G	None, None	—	81	AE22
PL[1]	PCR[134]	Option 0 Option 1 Option 2 Option 3	GPIO[134] — CANTX_1 —	ANS[18]	SIUL — FlexCAN_1 —	I/O	M / ANALO G	None, None	—	82	AE21
PL[2]	PCR[135]	Option 0 Option 1 Option 2 Option 3	GPIO[135] — CANRX_0 eMIOS1[22]	ANS[17]	SIUL — FlexCAN_0 PWM/Timer	I/O	S / ANALO G	None, None	—	83	AF22
PL[3]	PCR[136]	Option 0 Option 1 Option 2 Option 3	GPIO[136] — CANTX_0 eMIOS1[23]	ANS[16]	SIUL — FlexCAN_0 PWM/Timer	I/O	S / ANALO G	None, None	—	84	AF21

Table 7. Port pin summary (continued)

Port pin	PCR	Alternate function ¹	Function	Special function ²	Peripheral ³	I/O direction	Pad Type ⁴	RESET config ⁵	Pin number		
									176 LQFP	208 LQFP	416 TEPBGA
PL[4]	PCR[137]	Option 0 Option 1 Option 2 Option 3	GPIO[137] CS2_2 VIU5_PDI13 TCON[6]	—	SIUL DSPI_2 VIU2/PDI TCON	I/O	M	None, None	—	31	AB2
PL[5]	PCR[138]	Option 0 Option 1 Option 2 Option 3	GPIO[138] CS1_2 VIU6_PDI14 TCON[7]	—	SIUL DSPI_2 VIU2/PDI TCON	I/O	M	None, None	—	32	AC2
PL[6]	PCR[139]	Option 0 Option 1 Option 2 Option 3	GPIO[139] CS0_2 VIU7_PDI15 eMIOS1[18]	—	SIUL DSPI_2 VIU2/PDI PWM/Timer	I/O	S	None, None	—	33	AD1
PL[7]	PCR[140]	Option 0 Option 1 Option 2 Option 3	GPIO[140] SIN_2 VIU8_PDI16 eMIOS1[19]	—	SIUL DSPI_2 VIU2/PDI PWM/Timer	I/O	S	None, None	—	34	AE1
PL[8]	PCR[141]	Option 0 Option 1 Option 2 Option 3	GPIO[141] SOUT_2 VIU9_PDI17 eMIOS1[20]	—	SIUL DSPI_2 VIU2/PDI PWM/Timer	I/O	S	None, None	—	35	AF1
PL[9]	PCR[142]	Option 0 Option 1 Option 2 Option 3	GPIO[142] SCK_2 PDI_PCLK eMIOS1[21]	—	SIUL DSPI_2 PDI PWM/Timer	I/O	S	None, None	—	36	AF2
PL[10]	PCR[143]	Option 0 Option 1 Option 2 Option 3	GPIO[143] eMIOS1[10] DCULITE_G2 —	—	SIUL PWM/Timer DCULite —	I/O	M	None, None	—	174	C24
PL[11]	PCR[144]	Option 0 Option 1 Option 2 Option 3	GPIO[144] eMIOS1[11] DCULITE_G3 —	—	SIUL PWM/Timer DCULite —	I/O	M	None, None	—	175	A24

Table 7. Port pin summary (continued)

Port pin	PCR	Alternate function ¹	Function	Special function ²	Peripheral ³	I/O direction	Pad Type ⁴	RESET config ⁵	Pin number		
									176 LQFP	208 LQFP	416 TEPBGA
PL[12]	PCR[145]	Option 0 Option 1 Option 2 Option 3	GPIO[145] eMIOS1[12] DCULITE_G4 —	—	SIUL PWM/Timer DCULite —	I/O	M	None, None	—	176	C23
PL[13]	PCR[146]	Option 0 Option 1 Option 2 Option 3	GPIO[146] eMIOS1[13] DCULITE_G5 —	—	SIUL PWM/Timer DCULite —	I/O	M	None, None	—	177	B23
PL[14]	—	—	Reserved	—	—	—	—	—	—	—	—
PL[15]	—	—	Reserved	—	—	—	—	—	—	—	—
PORT M											
PM[0]	PCR[147]	Option 0 Option 1 Option 2 Option 3	GPIO[147] I2S_SCK / PWMOA DCULITE_R5 TCON[11]	—	SIUL SGM DCULite TCON	I/O	M	None, None	—	61	AE9
PM[1]	PCR[148]	Option 0 Option 1 Option 2 Option 3	GPIO[148] I2S_FS DCULITE_R6 —	—	SIUL SGM DCULite —	I/O	M	None, None	—	62	AF9
PM[2]	PCR[149]	Option 0 Option 1 Option 2 Option 3	GPIO[149] eMIOS1[17] DCULITE_R7 DCULITE_DE	RSDSCLKM	SIUL PWM/Timer DCULite DCULite	I/O	M	None, None	—	173	D23
PM[3]	PCR[150]	Option 0 Option 1 Option 2 Option 3	GPIO[150] CANRX_2 RXD_3 TCON[4]	—	SIUL FlexCAN_2 LINFlex_3 TCON	I/O	M	None, None	—	16	Y3
PM[4]	PCR[151]	Option 0 Option 1 Option 2 Option 3	GPIO[151] CANTX_2 TXD_3 TCON[5]	—	SIUL FlexCAN_2 LINFlex_3 TCON	I/O	M	None, None	—	17	Y2

Table 7. Port pin summary (continued)

Port pin	PCR	Alternate function ¹	Function	Special function ²	Peripheral ³	I/O direction	Pad Type ⁴	RESET config ⁵	Pin number		
									176 LQFP	208 LQFP	416 TEPBGA
PM[5]	PCR[152]	Option 0 Option 1 Option 2 Option 3	GPIO[152] VIU5_PDI13 eMIOS1[22] DCU_TAG	—	SIUL VIU2/PDI PWM/Timer DCU3	I/O	M	None, None	16	—	—
PM[6]	PCR[153]	Option 0 Option 1 Option 2 Option 3	GPIO[153] VIU6_PDI14 eMIOS1[23] DCULITE_TAG	—	SIUL VIU2/PDI PWM/Timer DCULite	I/O	M	None, None	17	—	—
PM[7]	PCR[154]	Option 0 Option 1 Option 2 Option 3	GPIO[154] VIU8_PDI16 I2S_DO / PWMO eMIOS1[16]	—	SIUL VIU2/PDI SGM PWM/Timer	I/O	S	None, None	39	—	—
PM[8]	PCR[155]	Option 0 Option 1 Option 2 Option 3	GPIO[155] VIU9_PDI17 I2S_SCK / PWMOA eMIOS1[23]	—	SIUL VIU2/PDI SGM PWM/Timer	I/O	S	None, None	40	—	—
PM[9]	PCR[156]	Option 0 Option 1 Option 2 Option 3	GPIO[156] PDI_PCLK SGM_MCLK eMIOS0[8]	—	SIUL PDI SGM PWM/Timer	I/O	M	None, None	113	—	—
PM[10]	PCR[157]	Option 0 Option 1 Option 2 Option 3	GPIO[157] RXD_2 CANRX_2 eMIOS0[16]	—	SIUL LINFlex_2 FlexCAN_2 PWM/Timer	I/O	S	None, None	114	—	—
PM[11]	PCR[158]	Option 0 Option 1 Option 2 Option 3	GPIO[158] TXD_2 CANTX_2 eMIOS0[23]	—	SIUL LINFlex_2 FlexCAN_2 PWM/Timer	I/O	S	None, None	115	—	—
PM[12]	PCR[159]	Option 0 Option 1 Option 2 Option 3	GPIO[159] DCULITE_B7 — I2S_SCK / PWMOA	—	SIUL DCULite — SGM	I/O	M	None, None	—	—	L24

Table 7. Port pin summary (continued)

Port pin	PCR	Alternate function ¹	Function	Special function ²	Peripheral ³	I/O direction	Pad Type ⁴	RESET config ⁵	Pin number		
									176 LQFP	208 LQFP	416 TEPBGA
PM[13]	PCR[160]	Option 0 Option 1 Option 2 Option 3	GPIO[160] DCULITE_PCLK — SGM_MCLK	—	SIUL DCULite — SGM	I/O	F	None, None	—	—	L23
PM[14]	—	—	Reserved	—	—	—	—	—	—	—	—
PM[15]	—	—	Reserved	—	—	—	—	—	—	—	—
PORT N											
PN[0]	PCR[161]	Option 0 Option 1 Option 2 Option 3	GPIO[161] DCULITE_HSYNC — TCON[4]	—	SIUL DCULite — TCON	I/O	M	None, None	—	—	AC3
PN[1]	PCR[162]	Option 0 Option 1 Option 2 Option 3	GPIO[162] DCULITE_VSYNC — TCON[5]	—	SIUL DCULite — TCON	I/O	M	None, None	—	—	AD3
PN[2]	PCR[163]	Option 0 Option 1 Option 2 Option 3	GPIO[163] DCULITE_R0 RXD_2 VIU0_PDI8	—	SIUL DCULite LINFlex_2 VIU2/PDI	I/O	M	None, None	—	—	AC10
PN[3]	PCR[164]	Option 0 Option 1 Option 2 Option 3	GPIO[164] DCULITE_R1 TXD_2 VIU1_PDI9	—	SIUL DCULite LINFlex_2 VIU2/PDI	I/O	M	None, None	—	—	AF10
PN[4]	PCR[165]	Option 0 Option 1 Option 2 Option 3	GPIO[165] DCULITE_R2 — TCON[6]	—	SIUL DCULite — TCON	I/O	M	None, None	—	—	AC11
PN[5]	PCR[166]	Option 0 Option 1 Option 2 Option 3	GPIO[166] DCULITE_R3 — TCON[7]	—	SIUL DCULite — TCON	I/O	M	None, None	—	—	AD11

Table 7. Port pin summary (continued)

Port pin	PCR	Alternate function ¹	Function	Special function ²	Peripheral ³	I/O direction	Pad Type ⁴	RESET config ⁵	Pin number		
									176 LQFP	208 LQFP	416 TEPBGA
PN[6]	PCR[167]	Option 0 Option 1 Option 2 Option 3	GPIO[167] DCULITE_R4 — TCON[8]	—	SIUL DCULite — TCON	I/O	M	None, None	—	—	AE11
PN[7]	PCR[168]	Option 0 Option 1 Option 2 Option 3	GPIO[168] DCULITE_R5 — TCON[9]	—	SIUL DCULite — TCON	I/O	M	None, None	—	—	AF11
PN[8]	PCR[169]	Option 0 Option 1 Option 2 Option 3	GPIO[169] DCULITE_R6 — TCON[10]	—	SIUL DCULite — TCON	I/O	M	None, None	—	—	AC12
PN[9]	PCR[170]	Option 0 Option 1 Option 2 Option 3	GPIO[170] DCULITE_R7 — TCON[11]	—	SIUL DCULite — TCON	I/O	M	None, None	—	—	AD12
PN[10]	PCR[171]	Option 0 Option 1 Option 2 Option 3	GPIO[171] DCULITE_G0 RXD_3 VIU2_PDI10	—	SIUL DCULite LINFlex_3 VIU2/PDI	I/O	M	None, None	—	—	AE12
PN[11]	PCR[172]	Option 0 Option 1 Option 2 Option 3	GPIO[172] DCULITE_G1 TXD_3 VIU3_PDI11	—	SIUL DCULite LINFlex_3 VIU2/PDI	I/O	M	None, None	—	—	AF12
PN[12]	PCR[173]	Option 0 Option 1 Option 2 Option 3	GPIO[173] DCULITE_G2 — eMIOS0[17]	—	SIUL DCULite — PWM/Timer	I/O	M	None, None	—	—	R26
PN[13]	PCR[174]	Option 0 Option 1 Option 2 Option 3	GPIO[174] DCULITE_G3 — eMIOS0[18]	—	SIUL DCULite — PWM/Timer	I/O	M	None, None	—	—	R25

Table 7. Port pin summary (continued)

Port pin	PCR	Alternate function ¹	Function	Special function ²	Peripheral ³	I/O direction	Pad Type ⁴	RESET config ⁵	Pin number		
									176 LQFP	208 LQFP	416 TEPBGA
PN[14]	PCR[175]	Option 0 Option 1 Option 2 Option 3	GPIO[175] DCULITE_G4 — eMIOS0[19]	—	SIUL DCULite — PWM/Timer	I/O	M	None, None	—	—	P26
PN[15]	PCR[176]	Option 0 Option 1 Option 2 Option 3	GPIO[176] DCULITE_G5 — eMIOS0[20]	—	SIUL DCULite — PWM/Timer	I/O	M	None, None	—	—	P24
PORT P											
PP[0]	PCR[177]	Option 0 Option 1 Option 2 Option 3	GPIO[177] DCULITE_G6 — eMIOS0[21]	—	SIUL DCULite — PWM/Timer	I/O	M	None, None	—	—	P23
PP[1]	PCR[178]	Option 0 Option 1 Option 2 Option 3	GPIO[178] DCULITE_G7 — eMIOS0[22]	—	SIUL DCULite — PWM/Timer	I/O	M	None, None	—	—	N26
PP[2]	PCR[179]	Option 0 Option 1 Option 2 Option 3	GPIO[179] DCULITE_B0 CANRX_2 VIU4_PDI12	—	SIUL DCULite FlexCAN_2 VIU2/PDI	I/O	M	None, None	—	—	N25
PP[3]	PCR[180]	Option 0 Option 1 Option 2 Option 3	GPIO[180] DCULITE_B1 CANTX_2 PDI_DE	—	SIUL DCULite FlexCAN_2 PDI	I/O	M	None, None	—	—	N23
PP[4]	PCR[181]	Option 0 Option 1 Option 2 Option 3	GPIO[181] DCULITE_B2 — eMIOS0[11]	—	SIUL DCULite — PWM/Timer	I/O	M	None, None	—	—	M26
PP[5]	PCR[182]	Option 0 Option 1 Option 2 Option 3	GPIO[182] DCULITE_B3 — eMIOS0[13]	—	SIUL DCULite — PWM/Timer	I/O	M	None, None	—	—	M25

Table 7. Port pin summary (continued)

Port pin	PCR	Alternate function ¹	Function	Special function ²	Peripheral ³	I/O direction	Pad Type ⁴	RESET config ⁵	Pin number		
									176 LQFP	208 LQFP	416 TEPBGA
PP[6]	PCR[183]	Option 0 Option 1 Option 2 Option 3	GPIO[183] DCULITE_B4 — eMIOS0[15]	—	SIUL DCULite — PWM/Timer	I/O	M	None, None	—	—	M24
PP[7]	PCR[184]	Option 0 Option 1 Option 2 Option 3	GPIO[184] DCULITE_B5 — I2S_FS	—	SIUL DCULite — SGM	I/O	M	None, None	—	—	M23
PP[8]	—	—	Reserved	—	—	—	—	—	—	—	—
PP[9]	—	—	Reserved	—	—	—	—	—	—	—	—
PP[10]	—	—	Reserved	—	—	—	—	—	—	—	—
PP[11]	—	—	Reserved	—	—	—	—	—	—	—	—
PP[12]	—	—	Reserved	—	—	—	—	—	—	—	—
PP[13]	—	—	Reserved	—	—	—	—	—	—	—	—
PP[14]	—	—	Reserved	—	—	—	—	—	—	—	—
PP[15]	—	—	Reserved	—	—	—	—	—	—	—	—

¹ Alternate functions are chosen by setting the values of the PCR[PA] bitfields inside the SIUL module.

PCR[PA] = 00 selects Option 0

PCR[PA] = 01 selects Option 1

PCR[PA] = 10 selects Option 2

PCR[PA] = 11 selects Option 3

This is intended to select the output functions. To use one of the input functions, the PCR[IBE] bit must be written to '1', regardless of the values selected in the PCR[PA] bitfields. For this reason, the value corresponding to an input only function is reported as "—".

² Special functions are enabled independently from the standard digital pin functions. Enabling standard I/O functions in the PCR registers may interfere with their functionality. ADC functions are enabled using the PCR[APC] bit; other functions are enabled by enabling the respective module.

³ Using the PSMI registers in the System Integration Unit Lite (SIUL), different pads can be multiplexed to the same peripheral input. Please see the SIUL chapter of the *MPC5645S Microcontroller Reference Manual* for details.

⁴ See the "Pad types" section for an explanation of the letters in this column.

⁵ Reset configuration is given as I/O direction and pull, e.g., "Input, pullup".

⁶ Out of reset pins PH[0:3] are available as JTAG pins (TCK, TDI, TDO and TMS respectively). It is up to the user to configure pins PH[0:3] when needed.

⁷ The following pad types are available for system pins and functional port pins:

Table 6. Pad Types

Pad	Function
S	Slow (pad_ssr, pad_ssr_hv)
M	Medium (pad_msr, pad_msr_hv)
F	Fast (pad_fc)
J	Input/output with analog features (pad_tgate, pad_tgate_hv)
Analog	Input only with analog features (pad_ae, pad_ae_hv)
SMD	Stepper Motor Detector
DDR	DDR pads
RSDS	RSDS pads

3 System design information

3.1 Power-up sequencing

The preferred power-up sequence for MPC5645S is as follows:

- Generic IO supplies or noise-free supplies, consisting of:
 - VDDA
 - VDDE_A
 - VDDE_B
 - VDDM
 - VDD_DR
 - VDD33_DR
 - VDDPLL
- All 3.3V supplies (VDDE_B & VDD33_DR) should be ramped up first, and then the rest of the I/O supplies should be ramped up (VDDA, VDDE_A, VDDM, VDD_DR).
- VDDR, the regulator input supply, should be the last supply to ramp up; all supplies can be ramped up together as long as VDDR is included. So all 5V supplies should be ramped up after the 3.3V supplies, and if all the supplies are of the same level, they can be ramped up together as well.
- LV supply (VDD12). If Vreg is in bypass mode and the core supply (1.2V) is supplied externally, then this should be the last supply given.

NOTE

For DDR, the 3.3 V supply (VDD33_DR) should come before VDD_DR.

This sequence ensures that when VREG releases its LVDs, the IO and other HV segments are powered properly. This is important because MPC5645S doesn't monitor LVDs on IO HV supplies.

4 Electrical characteristics

4.1 Introduction

This section contains electrical characteristics of the device as well as temperature and power considerations.

This product contains devices to protect the inputs against damage due to high static voltages. However, it is advisable to take precautions to avoid application of any voltage higher than the specified maximum rated voltages.

To enhance reliability, unused inputs can be driven to an appropriate logic voltage level (V_{DD} or V_{SS}). This could be done by internal pull up and pull down, which is provided by the product for most general purpose pins.

The parameters listed in the following tables represent the characteristics of the device and its demands on the system.

In the tables where the device logic provides signals with their respective timing characteristics, the symbol “CC” for Controller Characteristics is included in the Symbol column.

In the tables where the external system must provide signals with their respective timing characteristics to the device, the symbol “SR” for System Requirement is included in the Symbol column.

4.2 Parameter classification

The electrical parameters shown in this supplement are guaranteed by various methods. To give the customer a better understanding, the classifications listed in [Table 8](#) are used and the parameters are tagged accordingly in the tables where appropriate.

Table 8. Parameter Classifications

Classification tag	Tag description
P	Those parameters are guaranteed during production testing on each individual device.
C	Those parameters are achieved by the design characterization by measuring a statistically relevant sample size across process variations.
T	Those parameters are achieved by design characterization on a small sample size from typical devices under typical conditions unless otherwise noted. All values shown in the typical column are within this category.
D	Those parameters are derived mainly from simulations.

NOTE

The classification is shown in the column labeled “C” in the parameter tables where appropriate.

4.3 Absolute maximum ratings

Table 9. Absolute maximum ratings

Symbol		C	Parameter	Conditions	Value		Unit	SpecID
					Min	Max		
V _{DDA}	SR	D	Voltage on VDDA pin (ADC reference) with respect to ground (V _{SSA})		-0.3	+5.5	V	D1.1
				Relative to V _{DD}	V _{DD} -0.3	V _{DD} +0.3		
V _{SSA}	SR	D	Voltage on VSSA (ADC reference) pin with respect V _{SS}		V _{SS} -0.1	V _{SS} +0.1	V	D1.2
V _{DDPLL}	CC	D	Voltage on VDDPLL (1.2 V PLL supply) pin with respect to ground (V _{SSPLL})		1.08	1.32	V	D1.3
				Relative to V _{DD}	V _{DD} -0.3	V _{DD} +0.3		
V _{DDR}	SR	D	Voltage on VDDR pin (regulator supply) with respect to ground (V _{SSR})		-0.3	+5.5	V	D1.4
				Relative to V _{DD}	V _{DD} -0.3	V _{DD} +0.3		
V _{SSR}	SR	D	Voltage on VSSR (regulator ground) pin with respect to V _{SS}		V _{SS} -0.1	V _{SS} +0.1	V	D1.5
V _{DD12}	CC	D	Voltage on VDD12 pin with respect to ground (V _{SS12})		1.08	1.4	V	D1.6
V _{SS12}	CC	D	Voltage on VSS12 pin with respect to V _{SS}		V _{SS} -0.1	V _{SS} +0.1	V	D1.7
V _{DDE_A} ¹	SR	D	Voltage on VDDE_A (I/O supply) pin with respect to ground (V _{SSE_A})		-0.3	+5.5	V	D1.8
V _{DDE_B} ¹	SR	D	Voltage on VDDE_B (I/O supply) pin with respect to ground (V _{SS})		-0.3	+3.6	V	D1.9
V _{DDM} ¹	SR	D	Voltage on VDDM (stepper motor supply) pin with respect to ground (V _{SSM})		-0.3	+5.5	V	D1.10
V _{SS} ²	SR	D	I/O supply ground		0	0	V	D1.11
V _{DD_DR}		D	Voltage on VDDDDR with respect to V _{SS}		-0.3	3.6	V	D1.12
V _{RSDS}		D	Voltage on VDDRSDS with respect to V _{SS}		-0.3	3.6	V	D1.13
V _{IN}	SR	D	Voltage on any GPIO pin with respect to ground (V _{SS})		-0.3	V _{DDmax} (V _{DDE} max of that segment)	V	
I _{INJPAD}	SR	D	Injected input current on any pin during overload condition		-10	10	mA	D1.15
I _{INJSUM}	SR	D	Absolute sum of all injected input currents during overload condition		-50	50		D1.16
T _{STORAGE}	SR	T	Storage temperature		-55	150	°C	D1.17
ESD _{HBM}	SR	T	ESD Susceptibility (Human Body Model)			2000	V	D1.18

¹ Throughout the remainder of this document V_{DD} refers collectively to I/O voltage supplies, i.e., V_{DDE_A}, V_{DDE_B}, and V_{DDM}, unless otherwise noted.

² Throughout the remainder of this document V_{SS} refers collectively to I/O voltage supply grounds, i.e., V_{SSE_A}, V_{SSPLL}, and V_{SSM}, unless otherwise noted.

NOTE

Stresses exceeding the recommended absolute maximum ratings may cause permanent damage to the device. This is a stress rating only and functional operation of the device at these or any other conditions above those indicated in the operational sections of this specification are not implied. Exposure to absolute maximum rating conditions for extended periods may affect device reliability. During overload conditions ($V_{IN} > V_{DD}$ or $V_{IN} < V_{SS}$), the voltage on pins with respect to ground (V_{SS}) must not exceed the recommended values.

4.4 Recommended operating conditions

Table 10. Recommended operating conditions (3.3 V)

Symbol	C	Parameter	Conditions	Value		Unit	SpecID
				Min	Max		
V_{DDA}^1	SR	P Voltage on VDDA pin (ADC reference) with respect to ground (V_{SS})		+3.0	+3.6	V	D2.1
	D		Relative to V_{DD}	$V_{DD}-0.1$	$V_{DD}+0.1$		
V_{SSA}	SR	P Voltage on VSSA (ADC reference) pin with respect V_{SS}		$V_{SS}-0.1$	$V_{SS}+0.1$	V	D2.2
V_{DDPLL}	CC	P Voltage on VDDPLL (1.2 V PLL supply) pin with respect to ground (V_{SSPLL})		1.08	1.32	V	D2.3
V_{DDR}^2	SR	P Voltage on VDDR pin (regulator supply) with respect to ground (V_{SSR})		+3.0	+3.6	V	D2.4
	D		Relative to V_{DD}	$V_{DD}-0.1$	$V_{DD}+0.1$		
V_{SSR}	SR	D Voltage on VSSR (regulator ground) pin with respect to V_{SS}		$V_{SS}-0.1$	$V_{SS}+0.1$	V	D2.5
$V_{DD12}^{3,4}$	CC	P Voltage on VDD12 pin with respect to ground (V_{SS12})		1.08	1.4	V	D2.6
V_{SS12}	CC	D Voltage on VSS12 pin with respect to V_{SS}		$V_{SS}-0.1$	$V_{SS}+0.1$	V	D2.7
$V_{DD}^{5,6,7}$	SR	P Voltage on V_{DD} pins (V_{DDE_A} , V_{DDE_B} , V_{DD_DR} , V_{DDM}) with respect to ground (V_{SS})		V_{DDmin}^5	V_{DDmax}^5	V	D2.8
V_{SS}^8	SR	D I/O supply ground		0	0	V	D2.9
$V_{DDE_A}^9$	SR	P Voltage on VDDE_A (I/O supply) pin with respect to ground (V_{SSE_A})		+3.0	+3.6	V	D2.10
V_{DDE_B}	SR	P Voltage on VDDE_B (I/O supply) pin with respect to ground (V_{SSE_B})		+3.0	+3.6	V	D2.11
V_{DDM}	SR	P Voltage on VDDM (stepper motor supply) pin with respect to ground (V_{SSM})		+3.0	+3.6	V	D2.12
V_{DD_DR}		P Voltage on V_{DDDDR} with respect to V_{SS}		+1.62	+3.6	V	D2.13
V_{SS_DR}		D Voltage on V_{SSRSDS} with respect to V_{SS}		+1.62	+3.6	V	D2.14
V_{RSDS}		P Voltage on V_{DDDDR} with respect to V_{SS}		+3.0	+3.6	V	D2.15
TV_{DD}	SR	D V_{DD} slope to ensure correct power up ¹⁰			12	V/ms	D2.16
T_A	SR	P Ambient temperature under bias		-40	+105	°C	D2.17
T_J	SR	D Junction temperature under bias		-40	+150		D2.18

- ¹ 100 nF capacitance needs to be provided between V_{DDA}/V_{SSA} pair.
- ² 10 μ F capacitance must be connected between V_{DDR} and V_{SS12} because of a sharp surge due to external ballast.
- ³ V_{DD12} cannot be used to drive any external component.
- ⁴ Each V_{DD12}/V_{SS12} supply pair should have a 10 μ F capacitor. Absolute combined maximum capacitance is 40 μ F. Preferably, all the V_{DD12} supply pads should be shorted and then connected to a 4 \times 10 μ F capacitance. This is to ensure the ESR of external capacitance does not exceed 0.2 Ω . A 100 nF capacitor must be placed close to the pin.
- ⁵ V_{DD} refers collectively to I/O voltage supplies, i.e., V_{DDE_A} , V_{DDE_B} , V_{DD_DR} , and V_{DDM} .
- ⁶ 100 nF capacitance needs to be provided between each V_{DD}/V_{SS} pair. V_{DDmin} value for is 3 V for V_{DDE_A} & V_{DDM} as well as for V_{DDE_B} , while it is 1.62 V for V_{DD_DR} . V_{DD} max value is 3.6 V for V_{DDE_A} & V_{DDM} as well as for V_{DDE_B} & V_{DD_DR} .
- ⁷ Full electrical specification cannot be guaranteed when voltage drops below 3.0V. In particular, ADC electrical characteristics and I/O's DC electrical specification may not be guaranteed.
When voltage drops below V_{LVDHVL} device is reset.
- ⁸ V_{SS} refers collectively to I/O voltage supply grounds, i.e., V_{SSE_A} , V_{SS} , and V_{SSM} unless otherwise noted.
- ⁹ V_{DDE_A} should not be less than V_{DDA} .
- ¹⁰ Guaranteed by device validation.

4.5 Thermal characteristics

Table 11. Recommended operating conditions (5.0 V)

Symbol	C	Parameter	Conditions	Value		Unit	SpecID		
				Min	Max				
V _{DDA} ¹	SR	P	Voltage on VDDA pin (ADC reference) with respect to ground (V _{SS})		+4.5	+5.5	V	D2.19	
				D	Voltage drop ²	+3.0			+5.5
				D	Relative to V _{DD}	V _{DD} -0.1			V _{DD} +0.1
V _{SSA}	SR	D	Voltage on VSSA (ADC reference) pin with respect V _{SS}		V _{SS} -0.1	V _{SS} +0.1	V	D2.20	
V _{DDPLL}	CC	P	Voltage on VDDPLL (1.2 V PLL supply) pin with respect to ground (V _{SSPLL})		1.08	1.32	V	D2.21	
V _{DDR} ³	SR	P	Voltage on VDDR pin (regulator supply) with respect to ground (V _{SSR})		+3.0	+3.6	V	D2.22	
				D	Voltage drop ²	+3.0			+3.6
				D	Relative to V _{DD}	V _{DD} -0.1			V _{DD} +0.1
V _{SSR}	SR	D	Voltage on VSSR (regulator ground) pin with respect to V _{SS}		V _{SS} -0.1	V _{SS} +0.1	V	D2.23	
V _{DD12} ^{4,5}	CC	P	Voltage on VDD12 pin with respect to ground (V _{SS12})		1.08	1.4	V	D2.24	
V _{SS12}	CC	D	Voltage on VSS12 pin with respect to V _{SS}		V _{SS} -0.1	V _{SS} +0.1	V	D2.25	
V _{DD} ^{6,7}	SR	P	Voltage on VDD pins (VDDE_A, VDDE_B, VDD_DR, VDDMA, VDDMB, VDDMC) with respect to ground (V _{SS})	Voltage drop ²	V _{DDmin} ⁶	V _{DDmax} ⁶	V	D2.26	
V _{SS} ⁸	SR	D	I/O supply ground		0	0	V	D2.27	
V _{DDDE_A} ⁹	SR	P	Voltage on VDDE_A (I/O supply) pin with respect to ground (V _{SSE_A})		+4.5	+5.5	V	D2.28	
V _{DDDE_B} ¹⁰	SR	P	Voltage on VDDE_B (I/O supply) pin with respect to ground (V _{SSE_B})		+3.0	+3.6	V	D2.29	
V _{DDM}	SR	P	Voltage on VDDMA (stepper motor supply) pin with respect to ground (V _{SSMA})		+4.5	+5.5	V	D2.30	
V _{DD_DR} ¹¹		P	Voltage on V _{DD_DR} with respect to V _{SS}		+1.62	+3.6	V	D2.31	
V _{SS_DR}		D	Voltage on V _{SSRSDS} with respect to V _{SS}		+1.62	+3.6	V	D2.32	
V _{RSDS}		P	Voltage on V _{DD_DR} with respect to V _{SS}		+3.0	+3.6	V	D2.33	
TV _{DD}	SR	D	V _{DD} slope to ensure correct power up ¹²			12	V/ms	D2.34	
T _A	SR	P	Ambient temperature under bias		-40	+105	°C	D2.35	
					-40	+105			
T _J	SR	D	Junction temperature under bias		-40	+150		D2.36	

¹ 100 nF capacitance needs to be provided between V_{DDA}/V_{SSA} pair.

² Full functionality cannot be guaranteed when voltage drops below 4.5 V. In particular, I/O DC and ADC electrical characteristics may not be guaranteed below 4.5 V during the voltage drop sequence.

³ 10 μF capacitance must be connected between V_{DDR} and V_{SS12}. It is recommended that this cap should be placed, as close as possible to the DUT pin on board.

- ⁴ V_{DD12} cannot be used to drive any external component.
- ⁵ Each V_{DD12}/V_{SS12} supply pair should have a 10 μF capacitor. Absolute combined maximum capacitance is 40 μF . Preferably, all the V_{DD12} supply pads should be shorted and then connected to a $4 \times 10 \mu\text{F}$ capacitance. This is to ensure the ESR of external capacitance does not exceed 0.2 Ω . A 100 nF capacitor must be placed close to the pin.
- ⁶ V_{DD} refers collectively to I/O voltage supplies, i.e., V_{DDE_A} , V_{DDE_B} , V_{DDE_DR} , V_{DDMA} , V_{DDMB} and V_{DDMC} . VDDmin value for is 4.5 V for V_{DDE_A} & V_{DDM} , 3 V V_{DDE_B} , while it is 1.62 V for V_{DD_DR} . VDD max value is 5.5 V for V_{DDE_A} & V_{DDM} and 3.6 V for V_{DDE_B} & V_{DD_DR} .
- ⁷ 100 nF capacitance needs to be provided between each V_{DD}/V_{SS} pair
- ⁸ V_{SS} refers collectively to I/O voltage supply grounds, i.e., V_{SSE_A} , V_{SSE_B} , V_{SSE_A} , V_{SSE_E} , V_{SSMA} , V_{SSMB} and V_{SSMC}) unless otherwise noted.
- ⁹ V_{DDE_A} should not be less than V_{DDA} .
- ¹⁰ V_{DDE_B} cannot go beyond 3.6V under any operating condition.
- ¹¹ V_{DD_DR} can be 1.8, 2.5 and 3.3V (typical) based on type of SDR memory.
- ¹² Guaranteed by device validation

Table 12. Thermal characteristics for 176-pin LQFP¹

Symbol	C	D	Parameter	Conditions	Value	Unit	SpecID
$R_{\theta JA}$	CC	D	Junction to Ambient Natural Convection ²	Single layer board –1s	36	°C/W	D3.1
$R_{\theta JA}$	CC	D	Junction to Ambient Natural Convection ²	Four layer board –2s2p	29	°C/W	D3.2
$R_{\theta JMA}$	CC	D	Junction to Ambient ²	@200 ft./min., single layer board –1s	28	°C/W	D3.3
$R_{\theta JMA}$	CC	D	Junction to Ambient ²	@200 ft./min., Four layer board –2s2p	23	°C/W	D3.4
$R_{\theta JB}$	CC	D	Junction to Board ³		18	°C/W	D3.5
$R_{\theta JCtop}$	CC	D	Junction to Case (Top) ⁴		5	°C/W	D3.6
Ψ_{JT}	CC	D	Junction to Package Top Natural Convection ⁵		2	°C/W	D3.7

- ¹ Thermal characteristics are targets based on simulation that are subject to change per device characterization.
- ² Junction-to-Ambient Thermal Resistance determined per JEDEC JESD51-3 and JESD51-6. Thermal test board meets JEDEC specification for this package.
- ³ Junction-to-Board thermal resistance determined per JEDEC JESD51-8. Thermal test board meets JEDEC specification for the specified package.
- ⁴ Junction-to-Case at the top of the package determined using MIL-STD 883 Method 1012.1. The cold plate temperature is used for the case temperature. Reported value includes the thermal resistance of the interface layer.
- ⁵ Thermal characterization parameter indicating the temperature difference between the package top and the junction temperature per JEDEC JESD51-2. When Greek letters are not available, the thermal characterization parameter is written as Psi-JT.

Table 13. Thermal characteristics for 208-pin LQFP¹

Symbol	C	D	Parameter	Conditions	Value	Unit	SpecID
$R_{\theta JA}$	CC	D	Junction to Ambient Natural Convection ²	Single layer board –1s	34	°C/W	D3.8
$R_{\theta JA}$	CC	D	Junction to Ambient Natural Convection ²	Four layer board –2s2p	27	°C/W	D3.9
$R_{\theta JMA}$	CC	D	Junction to Ambient ²	@200 ft./min., single layer board –1s	27	°C/W	D3.10
$R_{\theta JMA}$	CC	D	Junction to Ambient ²	@200 ft./min., Four layer board –2s2p	22	°C/W	D3.11
$R_{\theta JB}$	CC	D	Junction to Board ³	—	18	°C/W	D3.12
$R_{\theta JCtop}$	CC	D	Junction to Case (Top) ⁴	—	5	°C/W	D3.13

Electrical characteristics

Table 13. Thermal characteristics for 208-pin LQFP¹ (continued)

Symbol	C	Parameter	Conditions	Value	Unit	SpecID
Ψ_{JT}	CC	D Junction to Package Top Natural Convection ⁵	—	2	°C/W	D3.14

¹ Thermal characteristics are targets based on simulation that are subject to change per device characterization.

² Junction-to-Ambient Thermal Resistance determined per JEDEC JESD51-3 and JESD51-6. Thermal test board meets JEDEC specification for this package.

³ Junction-to-Board thermal resistance determined per JEDEC JESD51-8. Thermal test board meets JEDEC specification for the specified package.

⁴ Junction-to-Case at the top of the package determined using MIL-STD 883 Method 1012.1. The cold plate temperature is used for the case temperature. Reported value includes the thermal resistance of the interface layer.

⁵ Thermal characterization parameter indicating the temperature difference between the package top and the junction temperature per JEDEC JESD51-2. When Greek letters are not available, the thermal characterization parameter is written as Psi-JT.

Table 14. Thermal characteristics for 416-pin TEPBGA¹

Symbol	C	Parameter	Conditions	Value	Unit	SpecID
$R_{\theta JA}$	CC	D Junction to Ambient Natural Convection ²	Single layer board –1s	26	°C/W	D3.15
$R_{\theta JA}$	CC	D Junction to Ambient Natural Convection ²	Four layer board –2s2p	18	°C/W	D3.16
$R_{\theta JMA}$	CC	D Junction to Ambient ²	@200 ft./min., single layer board –1s	20	°C/W	D3.17
$R_{\theta JMA}$	CC	D Junction to Ambient ²	@200 ft./min., Four layer board –2s2p	15	°C/W	D3.18
$R_{\theta JB}$	CC	D Junction to Board ³	—	10	°C/W	D3.19
$R_{\theta Jc top}$	CC	D Junction to Case (Top) ⁴	—	6	°C/W	D3.20
Ψ_{JT}	CC	D Junction to Package Top Natural Convection ⁵	—	2	°C/W	D3.21

¹ Thermal characteristics are targets based on simulation that are subject to change per device characterization.

² Junction-to-Ambient Thermal Resistance determined per JEDEC JESD51-3 and JESD51-6. Thermal test board meets JEDEC specification for this package.

³ Junction-to-Board thermal resistance determined per JEDEC JESD51-8. Thermal test board meets JEDEC specification for the specified package.

⁴ Junction-to-Case at the top of the package determined using MIL-STD 883 Method 1012.1. The cold plate temperature is used for the case temperature. Reported value includes the thermal resistance of the interface layer.

⁵ Thermal characterization parameter indicating the temperature difference between the package top and the junction temperature per JEDEC JESD51-2. When Greek letters are not available, the thermal characterization parameter is written as Psi-JT.

4.5.1 General notes for specifications at maximum junction temperature

An estimate of the chip junction temperature, T_J , can be obtained from the equation:

$$T_J = T_A + (R_{\theta JA} * P_D) \quad \text{Eqn. 1}$$

where:

T_A = ambient temperature for the package (°C)

$R_{\theta JA}$ = junction to ambient thermal resistance (°C/W)

P_D = power dissipation in the package (W)

The thermal resistance values used are based on the JEDEC JESD51 series of standards to provide consistent values for estimations and comparisons. The difference between the values determined for the single-layer (1s) board compared to a four-layer board that has two signal layers, a power and a ground plane (2s2p), demonstrate that the effective thermal resistance is not a constant. The thermal resistance depends on the:

- Construction of the application board (number of planes)
- Effective size of the board which cools the component
- Quality of the thermal and electrical connections to the planes
- Power dissipated by adjacent components

Connect all the ground and power balls to the respective planes with one via per ball. Using fewer vias to connect the package to the planes reduces the thermal performance. Thinner planes also reduce the thermal performance. When the clearance between the vias leave the planes virtually disconnected, the thermal performance is also greatly reduced.

As a general rule, the value obtained on a single-layer board is within the normal range for the tightly packed printed circuit board. The value obtained on a board with the internal planes is usually within the normal range if the application board has:

- One oz. (35 micron nominal thickness) internal planes
- Components are well separated
- Overall power dissipation on the board is less than 0.02 W/cm²

The thermal performance of any component depends on the power dissipation of the surrounding components. In addition, the ambient temperature varies widely within the application. For many natural convection and especially closed box applications, the board temperature at the perimeter (edge) of the package is approximately the same as the local air temperature near the device. Specifying the local ambient conditions explicitly as the board temperature provides a more precise description of the local ambient conditions that determine the temperature of the device.

At a known board temperature, the junction temperature is estimated using the following equation:

$$T_J = T_B + (R_{\theta JB} * P_D) \quad \text{Eqn. 2}$$

where:

T_B = board temperature for the package perimeter (°C)

$R_{\theta JB}$ = junction-to-board thermal resistance (°C/W) per JESD51-8S

P_D = power dissipation in the package (W)

When the heat loss from the package case to the air does not factor into the calculation, an acceptable value for the junction temperature is predictable. Ensure the application board is similar to the thermal test condition, with the component soldered to a board with internal planes.

The thermal resistance is expressed as the sum of a junction-to-case thermal resistance plus a case-to-ambient thermal resistance:

$$R_{\theta JA} = R_{\theta JC} + R_{\theta CA} \quad \text{Eqn. 3}$$

where:

$R_{\theta JA}$ = junction to ambient thermal resistance (°C/W)

$R_{\theta JC}$ = junction to case thermal resistance (°C/W)

$R_{\theta CA}$ = case to ambient thermal resistance (°C/W)

$R_{\theta JC}$ is device related and is not affected by other factors. The thermal environment can be controlled to change the case-to-ambient thermal resistance, $R_{\theta CA}$. For example, change the air flow around the device, add a heat sink, change the mounting arrangement on the printed circuit board, or change the thermal dissipation on the printed circuit board surrounding the device. This description is most useful for packages with heat sinks where 90% of the heat flow is through the case to heat sink to ambient. For most packages, a better model is required.

Electrical characteristics

A more accurate two-resistor thermal model can be constructed from the junction-to-board thermal resistance and the junction-to-case thermal resistance. The junction-to-case thermal resistance describes when using a heat sink or where a substantial amount of heat is dissipated from the top of the package. The junction-to-board thermal resistance describes the thermal performance when most of the heat is conducted to the printed circuit board. This model can be used to generate simple estimations and for computational fluid dynamics (CFD) thermal models.

To determine the junction temperature of the device in the application on a prototype board, use the thermal characterization parameter (Ψ_{JT}) to determine the junction temperature by measuring the temperature at the top center of the package case using the following equation:

$$T_J = T_T + (\Psi_{JT} \times P_D) \quad \text{Eqn. 4}$$

where:

T_T = thermocouple temperature on top of the package ($^{\circ}\text{C}$)

Ψ_{JT} = thermal characterization parameter ($^{\circ}\text{C}/\text{W}$)

P_D = power dissipation in the package (W)

The thermal characterization parameter is measured in compliance with the JESD51-2 specification using a 40-gauge type T thermocouple epoxied to the top center of the package case. Position the thermocouple so that the thermocouple junction rests on the package. Place a small amount of epoxy on the thermocouple junction and approximately 1 mm of wire extending from the junction. Place the thermocouple wire flat against the package case to avoid measurement errors caused by the cooling effects of the thermocouple wire.

References:

Semiconductor Equipment and Materials International
805 East Middlefield Rd.
Mountain View, CA 94043
(415) 964-5111

MIL-SPEC and EIA/JESD (JEDEC) specifications are available from Global Engineering Documents at 800-854-7179 or 303-397-7956.

JEDEC specifications are available on the WEB at <http://www.jedec.org>.

4.6 EMI (electromagnetic interference) characteristics

Table 15. EMI testing specifications^{1 2}

Symbol	Parameter	Conditions	Clocks	Frequency Range	Level (Typ)	Unit
Radiated Emissions	V _{EME}	Device Configuration, test conditions and EM testing per standard IEC61967-2	FOSC - 8MHz, External Crystal FCPU -124MHz FBUS -124MHz No PLL Frequency Modulation	150 kHz - 50 MHz	19	dBμV
				50 MHz - 150 MHz	30	
				150 MHz - 500 MHz	25	
				500 MHz - 1000 MHz	19	
				IEC Level	K	
			FOSC - 8MHz, External Crystal FCPU -124MHz FBUS -124MHz 2% PLL Frequency Modulation	150 kHz - 50 MHz	15	dBμV
				50 MHz - 150 MHz	24	
				150 MHz - 500 MHz	17	
				500 MHz - 1000 MHz	14	
				IEC Level	L	

¹ The reported emission level is the value of the maximum emission, rounded up to the next whole number.

² IEC Level Maximum: L is less than or equal to 24 dBμV, K is less than or equal to 30 dBμV.

4.7 Power management

4.7.1 Voltage regulator electrical characteristics

The internal voltage regulator requires an external NPN (BCP68 or NJD2873) ballast to be connected as shown in [Figure 7](#) as well as an external capacitance (C_{REG}) to be connected to the device in order to provide a stable low voltage digital supply to the device. Capacitances should be placed on the board as near as possible to the associated pins. Care should also be taken to limit the serial inductance of the board to less than 15 nH.

For the MPC5645S microcontroller, 100 nF should be placed between each V_{DD12}/V_{SS12} supply pair and also between the V_{DDPLL}/V_{SSPLL} pair. Additionally, 10 μF should be placed between the V_{DDR} pin and the adjacent V_{SS} pin.

V_{DDR} = 3.0 V to 3.6 V / 4.5 V to 5.5 V, T_A = -40 to 105 °C, unless otherwise specified.

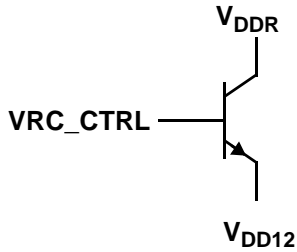

Figure 7. External NPN ballast connections

Table 16. Voltage regulator electrical characteristics¹

Symbol		C	Parameter	Conditions	Min	Max	Unit	SpecID	
V _{DDR}	SR	P	Power supply		3.0	5.5	V	D5.1	
T _J	SR	D	Junction temperature		-40	150	°C	D5.2	
I _{REG}	CC	T	Current consumption	Reference included, @ 55 °C No load @ Full load	—	2 11	mA	D5.3	
I _L	CC	T	Output current capacity	DC load current	—	450	mA	D5.4	
V _{DD12}	CC	D	Output voltage (value @ I _L = 0 @ 27°C)	Pre-trimming sigma < 7 mV	—	1.330	V	D5.5	
		P		Post-trimming	1.270	1.280			
		T	Output voltage (value @ I _L = I _{max})	Post-trimming	1.145	—			
	SR	D	External decoupling/stability capacitor	4 capacitances of 10 µF each	10 * 4		µF	D5.6	
		D		ESR of external cap	0.05	0.2			ohm
		D		1 bond wire R + 1 pad R	0.2	1			ohm
L _{BOND}	CC	D	Bonding Inductance for Bipolar Base Control pad		0	15	nH	D5.7	
	CC	D	Power supply rejection	@ DC @ no load	Load = 10 µF * 4	—	-30	dB	D5.8
				@ 200 kHz @ no load		-100			
				@ DC @ 400 mA		-30			
				@ 200 kHz @ 400 mA		-30			
	CC	D	Load current transient	Load = 10 µF * 4	—	10% to 90% of I _L (max) in 100 ns		D5.9	
t _{SU}	CC	T	Start-up time after input supply stabilizes ²	Load = 10 µF * 4	—	500	µs	D5.10	

¹ All values in this table are PRELIMINARY.

² Time after the input supply to the voltage regulator has ramped up (VDDR) and the voltage regulator has asserted the Power OK signal.

4.7.2 Voltage monitor electrical characteristics

The device implements a Power On Reset module to ensure correct power-up initialization, as well as four low voltage detectors to monitor the V_{DD} and the V_{DD12} voltage while device is supplied:

- POR monitors V_{DD} during the power-up phase to ensure device is maintained in a safe reset state
- LVDHV3 monitors V_{DD} to ensure device reset below minimum functional supply
- LVDHV5 monitors V_{DD} when application uses device in the $5.0V \pm 10\%$ range
- LVDLVCOR monitors power domain No. 1
- LVDLVBKP monitors power domain No. 0

Table 17. Low voltage monitor electrical characteristics

Symbol	C	Parameter	Conditions ¹	Value ²			Unit	SpecID	
				Min	Typ	Max			
V_{PORH}	CC	C	Power-on reset threshold	$T_A = 25^\circ\text{C}$, after trimming	1.5	—	2.7	V	D5.11
$V_{LVDHV3H}$	CC	C	LVDHV3 low voltage detector high threshold		—	—	2.8		D5.12
$V_{LVDHV3L}$	CC	C	LVDHV3 low voltage detector low threshold		2.7	—	—		D5.13
$V_{LVDHV5H}$	CC	C	LVDHV5 low voltage detector high threshold		—	—	4.37		D5.14
$V_{LVDHV5L}$	CC	C	LVDHV5 low voltage detector low threshold		4.2	—	—		D5.15
$V_{LVDLVCORH}$	CC	C	LVDLVCOR low voltage detector high threshold		—	—	1.185		D5.16
$V_{LVDLVCORL}$	CC	C	LVDLVCOR low voltage detector low threshold		1.095	—	—		D5.17

¹ $V_{DD} = 3.3V \pm 10\% / 5.0V \pm 10\%$, $T_A = -40 / +105^\circ\text{C}$, unless otherwise specified

² All values need to be confirmed during device validation.

4.7.3 Low voltage domain power consumption

Table 18 provides DC electrical characteristics for significant application modes. These values are indicative values; actual consumption depends on the application.

Table 18. DC electrical characteristics

Symbol	C	Parameter	Conditions ¹	Value ²			Unit		
				Min	Typ	Max			
I_{DDMAX}^2	CC	D	RUN mode maximum average current	—	250	276.63 ³	mA		
I_{DDRUN}^4	CC	P	RUN mode typical average current ⁵	$f_{CPU} = 125\text{MHz}$, Dual Display Drive with external DRAM, 416 TEPBGA package option only	—	230	—	mA	
					—	306	—		
I_{DDHALT}	CC	C	HALT mode current ⁶	Slow internal RC oscillator (128KHz) running	$T_A = 25^\circ\text{C}$	—	12.67	18.26	mA
					$T_B = 105^\circ\text{C}$	—	33.1	36.41	

Table 18. DC electrical characteristics (continued)

Symbol	C	Parameter	Conditions ¹	Value ²			Unit			
				Min	Typ	Max				
I _{DDSTOP}	CC	D	STOP mode current ⁷ Slow internal RC oscillator (128KHz) running	T _A = -40°C	—	645	—	μA		
				T _A = 0°C	—	1100	—			
				T _A = 25°C	—	1531	1615			
		D			T _A = 55°C	—	3.8	—	mA	
					T _A = 85°C	—	9.7	—		
		P				T _A = 105°C	—	17.67		18.46
I _{DDSTBY2}	CC	D	STANDBY2 mode current ⁸ (64K SRAM on)	T _A = -40°C	—	470	—	μA		
				T _A = 0°C	—	480	—			
				T _A = 25°C	—	481	490			
				T _A = 55°C	—	525	—			
				T _A = 85°C	—	650	—			
				T _A = 105°C	—	870	910			
	CC	D		SXOSC (32KHz) and RTC OFF	T _A = -40°C		63	—	μA	
					T _A = 0°C		85	—		
					T _A = 25°C		93	100		
					T _A = 55°C		95	—		
					T _A = 85°C		190	—		
					T _A = 105°C		390	430		
I _{DDSTBY1}	CC	D	STANDBY1 mode current (8K SRAM on) ⁹	T _A = -40°C	—	415	—	μA		
				T _A = 0°C	—	422	—			
				T _A = 25°C	—	426	430			
				T _A = 55°C	—	575	—			
				T _A = 85°C	-	680	—			
				T _A = 105°C	—	810	915			
	CC	D		SXOSC (32 KHz) and RTC OFF	T _A = -40°C		20	—	μA	
					T _A = 0°C		22	—		
					T _A = 25°C		29	45		
					T _A = 55°C		47	—		
					T _A = 85°C		118	—		
					T _A = 105°C		236	310		

¹ V_{DD} = 3.0V to 5.5V, T_A = -40 to 105 °C, unless otherwise specified.

- ² I_{DDMAX} is composed of the current consumption on all supplies (V_{DD12} , V_{DDE_A} , V_{DDE_B} , V_{DDA} , V_{DDR} , V_{DDM} , V_{DDPLL} , V_{DD_DR}). It does not include current consumption linked to I/Os toggling which is highly dependent on the application. The given value is thought to be a worst case value with all peripherals running, and code fetched from code flash while modify operation on-going on data flash. It is to be noticed that this value can be significantly reduced by application; switch-off not used peripherals (default), reduce peripheral frequency through internal prescaler, fetch from RAM most used functions, use low power mode when possible.
- ³ Higher current may be sinked by device during power-up and standby exit. Please refer to inrush current in [Table 19](#).
- ⁴ RUN current measured with typical application and accesses on both flash and RAM.
- ⁵ Data and Code Flash in Normal Power. Code fetched from RAM: DCUs running with 20MHz pixel clock, QuadSPI fetching data at 80MHz, GPU accessing internal SRAM and external DRAM, DMA, RLE, and VIU active, Serial IPs CAN and LIN in loop back mode, DSPI as Master, PLL as system Clock (4 x Multiplier) peripherals on (eMIOS/ADC/SMD/SSD/SGM) and running at max frequency, periodic SW/WDG timer reset enabled.
- ⁶ Flash in Low Power. RC-osc128KHz & RC-OSC 16MHz on. 10MHz XTAL clock. FlexCAN: instances: 0, 1 ON (clocked but no reception or transmission), LINFLEX: instances 0, 1, 2 ON (clocked but no reception or transmission). eMIOS: instance: 0, 1 ON - 16 channels on with PWM20KHz. DSPI: instance: 0 (clocked but no communication). DCUs, TCON, VIU, GPU clock gated, RTC/API ON. PIT ON. STM ON. ADC ON but not converting.
- ⁷ No clock, RC 16MHz off, RCI 128KHz on, PLL off, HPVreg off, ULPVreg/LPVreg on. All possible peripherals off and clock gated. Flash in power down mode.
- ⁸ ULPreg ON, HP/LPVreg off, 64KB RAM on, device configured for minimum consumption, all possible modules switched-off.
- ⁹ ULPreg ON, HP/LPVreg off, 8KB RAM on, device configured for minimum consumption, all possible modules switched-off.

4.8 DC electrical specifications

4.8.1 DC specification for CMOS090LP2 library @ VDDE = 3.3 V

NOTE

These pad specifications are applicable for pads in the Digital segment Only. See the "GPIO power bank supplies and functionality" table in the "Voltage Regulators and Power Supplies" chapter of the reference manual for details.

Table 19. DC electrical specifications

Symbol	C	Parameter	Condition	Value		Unit	SpecID	
				Min	Max			
Vdd	SR	P	Core supply voltage	—	1.08	1.47	V	D9.1
Vdde	SR	P	I/O supply voltage	—	3.0	3.6	V	D9.2
Vdd33	SR	P	I/O pre-driver supply voltage	—	3.0	3.6	V	D9.3
Vih_c	SR	P	CMOS input buffer high voltage	With hysteresis enabled	0.65×Vdde	Vdde+0.3	V	D9.4
				With hysteresis disabled	0.55×Vdde	Vdde+0.3		
Vil_c	SR	P	CMOS input buffer low voltage	With hysteresis enabled	Vss−0.3	0.35×Vdde	V	D9.5
				With hysteresis disabled	Vss−0.3	0.40×Vdde		
Vhys_c	SR	T	CMOS input buffer hysteresis	—	0.1×Vdde	—	V	D9.6
Vih_fod_h	SR	P	5 V tolerant CMOS input buffer high voltage	With hysteresis enabled	0.65×Vdd33	Vdd33+0.3	V	D9.7
Vil_fod_h	SR	P	5 V tolerant CMOS input buffer low voltage	With hysteresis enabled	Vss−0.3	0.35×Vdd33	V	D9.8

Table 19. DC electrical specifications (continued)

Symbol		C	Parameter	Condition	Value		Unit	SpecID
					Min	Max		
lact_s	SR	T	Selectable weak pullup/pulldown current	—	25	150	μA	D9.9
linact_d	SR	P	Digital pad input leakage current	Weak pull inactive	-2.5	2.5	μA	D9.10
linact_a	SR	P	Analog pad input leakage current	Weak pull inactive	-150	150	μA	D9.11
Voh	SR	P	Output high voltage	Refer to Table 20	0.8 × Vdde	—	V	D9.12
Vol	SR	P	Output low voltage	Refer to Table 20	—	0.2×Vdde	V	D9.13
Vol_fod_h	SR	P	Fast open-drain output low voltage	Iol_fod_h = 10 mA	—	0.2×Vdd33		D9.16

Table 20. Drive current, VDDE=3.3 V (+/- 10%)

Pad	C	Drive mode	Minimum Ioh (mA) ¹	Minimum Iol (mA) ²
pad_fc	C	00	16.1	24
		01	31.8	47.9
		10	47.2	70.6
		11	77	114.5
pad_msr	P	All	61.9	83.6
pad_ssr	P	All	61.9	83.6

¹ Ioh is defined as the current sourced by the pad to drive the output to Voh.

² Iol is defined as the current sunk by the pad to drive the output to Vol.

Table 21. Supply leakage

Pad	C	VDD	VDDE (Typ/Max)	VDD33 (Typ/Max)
pad_fc	D	90 μA	3 nA / 4 μA	1 nA / 30 μA
pad_msr		—	—	—
pad_ssr		—	—	—

4.8.2 DC specification for CMOS090LP2fg library @ VDDE = 5.0 V

NOTE

These pad specifications are applicable for pads in the Analog segment Only. See the "GPIO power bank supplies and functionality" table in the "Voltage Regulators and Power Supplies" chapter of the reference manual for details.

Table 22. DC electrical specifications

Symbol	C	Parameter	Condition	Value		Unit	SpecID	
				Min	Max			
Vdd	SR	P	Core supply voltage	—	1.08	1.32	V	D9.17
Vdde	SR	P	I/O supply voltage	—	4.5	5.5	V	D9.18
Vdd33	SR	P	I/O pre-driver supply voltage	—	3.0	3.6	V	D9.19
Vih_hys	SR	P	CMOS input buffer high voltage	With hysteresis enabled	0.65×Vdde	Vdde+0.3	V	D9.20
Vil_hys	SR	P	CMOS input buffer low voltage	With hysteresis enabled	Vss–0.3	0.35×Vdde	V	D9.21
Vih	SR	P	CMOS input buffer high voltage	With hysteresis disabled	0.55×Vdde	Vdde+0.3	V	D9.22
Vil	SR	P	CMOS input buffer low voltage	With hysteresis disabled	Vss–0.3	0.40×Vdde	V	D9.23
Vhys	SR	T	CMOS input buffer hysteresis	—	0.1×Vdde	—	V	D9.24
Pull_loh	SR	P	Weak pullup current	—	35	135	μA	D9.25
Pull_lol	SR	P	Weak pulldown current	—	35	200	μA	D9.26
linact_d	SR	P	Digital pad input leakage current	Weak pull inactive	–2.5	2.5	μA	D9.27
linact_a	SR	P	Analog pad input leakage current	Weak pull inactive	–150	150	μA	D9.28
Voh	SR	P	Slew rate controlled output high voltage	—	0.8×Vdde	—	V	D9.29
Vol	SR	P	Slew rate controlled output low voltage	—	—	0.2×Vdde	V	D9.30
Voh_ls	SR	P	Low swing output pad output high voltage	—	2.64	—	V	D9.31
loh_msr	SR	C	pad_msr_hv loh	—	11.6	40.7	mA	D9.32
lol_msr	SR	C	pad_msr_hv lol	—	17.7	68.2	mA	D9.33
loh_ssr	SR	C	pad_ssr_hv loh	—	6.0	21.3	mA	D9.34
lol_ssr	SR	C	pad_ssr_hv lol	—	9.2	36.3	mA	D9.35
Rtgate	SR	D	Pad_tgate_hv input resistance	—	250	800	Ω	D9.39

Table 23. DC electrical specifications

Symbol		Parameter	Condition	Value		Unit	SpecID
				Min	Max		
Vdd	SR	Core supply voltage	—	1.08	1.32	V	D9.45
Vdde	SR	I/O supply voltage	—	3.0	3.6	V	D9.46
Vdd33	SR	I/O pre-driver supply voltage	—	3.0	3.6	V	D9.47
Vih_hys	SR	CMOS input buffer high voltage	With hysteresis enabled	$0.65 \times V_{dde}$	$V_{dde} + 0.3$	V	D9.48
Vil_hys	SR	CMOS input buffer low voltage	With hysteresis enabled	$V_{ss} - 0.3$	$0.35 \times V_{dde}$	V	D9.49
Vih	SR	CMOS input buffer high voltage	With hysteresis disabled	$0.55 \times V_{dde}$	$V_{dde} + 0.3$	V	D9.50
Vil	SR	CMOS input buffer low voltage	With hysteresis disabled	$V_{ss} - 0.3$	$0.40 \times V_{dde}$	V	D9.51
Vhys	SR	CMOS input buffer hysteresis	—	$0.1 \times V_{dde}$	—	V	D9.52
Pull_loh	SR	Weak pullup current	—	15	70	μ A	D9.53
Pull_lol	SR	Weak pulldown current	—	15	95	μ A	D9.54
Iinact_d	SR	Digital pad input leakage current	Weak pull inactive	-2.5	2.5	μ A	D9.55
Iinact_a	SR	Analog pad input leakage current	Weak pull inactive	-150	150	μ A	D9.56
Voh	SR	Slew rate controlled output high voltage	—	$0.8 \times V_{dde}$	—	V	D9.57
Vol	SR	Slew rate controlled output low voltage	—	—	$0.2 \times V_{dde}$	V	D9.58
Ioh_msr	SR	pad_msr_hv loh	—	5.4	21	mA	D9.59
Iol_msr	SR	pad_msr_hv lol	—	8.1	38.6	mA	D9.60
Ioh_ssr	SR	pad_ssr_hv loh	—	2.8	11.2	mA	D9.61
Iol_ssr	SR	pad_ssr_hv lol	—	4.2	20.6	mA	D9.62
Rtgate	SR	Pad_tgate_hv input resistance	—	325	1250	Ω	D9.65

Table 24. Supply leakage

Pad	VDD		VDDE		VDD33	
	Typ	Max	Typ	Max	Typ	Max
pad_msr_hv	0.818 nA	83.7 nA	0.81 nA	118 nA	—	—
pad_ssr_hv	0.818 nA	83.7 nA	0.858 nA	88.7 nA	—	—
pad_i_hv	0.307 nA	48.4 nA	88.2 pA	30 nA	—	—
biasref_hv	—	—	—	—	—	—

Table 24. Supply leakage (continued)

Pad	VDD		VDDE		VDD33	
	Typ	Max	Typ	Max	Typ	Max
core_v_det_hv	0	0	—	—	0	0
core_v_det_lp_hv	0	0	—	—	—	—
corner_esdpadcell_hv	—	—	—	—	—	—
corner_esdpadcell_id00_hv	—	—	—	—	—	—
corner_esdpadcell_id11_hv	—	—	—	—	—	—
corner_esdpadcell_lp_hv	—	—	—	—	—	—
esd_term_35_84_hv	—	—	—	—	—	—
pad_9v_hv	0	0	—	—	—	—
pad_ae_hv	—	—	—	—	—	—
pad_esdspacer_hv	—	—	—	—	—	—
pad_tgate_hv	—	—	—	—	—	—
pad_vdd33_hv	—	—	—	—	—	—
pad_vdde_hv	0	0	—	—	0	0
pad_vddint3v_hv	0	0	—	—	0	0
pad_vddint_hv	0	0	—	—	—	—
pad_vss_hv	0	0	—	—	—	—
pad_vsse_hv	0	0	—	—	—	—
pad_vssint3v_hv	0	0	—	—	—	—
pad_vssint_hv	0	0	—	—	—	—
spr_17_82_hv	—	—	—	—	—	—
spr_35_84_hv	—	—	—	—	—	—
spr_71_88_hv	—	—	—	—	—	—
spr_143_38_hv	—	—	—	—	—	—
spr_vdde_lvl_hv	—	—	—	—	—	—

Table 25. AVG IDDE specifications

Cell	Period (ns)	Load (pF) ¹	VDDE (V)	Drive/slew select	IDDE (mA)
pad_msr_hv ²	24	50	5.5	11	14
	62	50	5.5	01	5.3
	317	50	5.5	00	1.1
	425	200	5.5	00	3

Table 25. AVG IDDE specifications (continued)

Cell	Period (ns)	Load (pF) ¹	VDDE (V)	Drive/slew select	IDDE (mA)
pad_ssr_hv ²	37	50	5.5	11	9
	130	50	5.5	01	2.5
	650	50	5.5	00	0.5
	840	200	5.5	00	1.5

¹ All loads are lumped loads.

² Average current is for pad configured as output only. Use pad_i current for input.

4.8.3 DC specification for CMOS090_dds library @ VDDE = 3.3 V

Table 26. DC electrical specifications at 3.3 V VDDE

Symbol		Parameter	Value		Unit	SpecID
			Min	Max		
Vdd	SR	Core supply voltage	1.08	1.32	V	D9.71
			1.08	1.47		
Vdde	SR	I/O supply voltage	3.0	3.6	V	D9.72
Vdd33	SR	I/O pre-driver supply voltage	3.0	3.6	V	D9.73
Vref	SR	Input reference voltage	1.3	1.7	V	D9.74
Vtt	SR	Termination voltage	Vref-0.05	Vref+0.05	V	D9.75
Vih	SR	Input high voltage	Vref+0.20	—	V	D9.76
Vil	SR	Input low voltage	—	Vref-0.2	V	D9.77
Voh	SR	Output high voltage	Vtt+0.8	—	V	D9.78
Vol	SR	Output low voltage	—	Vtt-0.8	V	D9.79

Table 27. Output drive current @ VDDE = 3.3 V (+/-10%)

Pad	C	Drive mode	Minimum loh (mA)	Minimum lol (mA)
pad_st_acc	P	111	-16	16
pad_st_dq	P	111	-16	16
pad_st_clk	P	111	-16	16
pad_st	P	111	-16	16
pad_st_odt	P	111	-16	16
pad_st_ck	P	111	-16	16

4.8.4 DC specification for CMOS090_dds library @ VDDE = 2.5 V

Table 28. DC electrical specifications at 2.5 V VDDE

Symbol		C	Parameter	Value		Unit	SpecID
				Min	Max		
Vdd	SR	P	Core supply voltage	1.08	1.32	V	D9.80
				1.08	1.47		
Vdde	SR	P	I/O supply voltage	2.3	2.7	V	D9.81
Vdd33	SR	P	I/O pre-driver supply voltage	3.0	3.6	V	D9.82
Vref	SR	P	Input reference voltage	$0.49 \times V_{dde}$	$0.51 \times V_{dde}$	V	D9.83
Vtt	SR	P	Termination voltage	$V_{ref} - 0.04$	$V_{ref} + 0.04$	V	D9.84
Vih	SR	P	Input high voltage	$V_{ref} + 0.15$	—	V	D9.85
Vil	SR	P	Input low voltage	—	$V_{ref} - 0.15$	V	D9.86
Voh	SR	P	Output high voltage	$V_{tt} + 0.81$	—	V	D9.87
Vol	SR	P	Output low voltage	—	$V_{tt} - 0.81$	V	D9.88

Table 29. Output drive current @ VDDE = 2.5 V (+/-200mV)

Pad	C	Drive mode	Minimum loh (mA)	Minimum lol (mA)	Libraries
pad_st_acc	P	011	-16.2	16.2	6MDDR
pad_st_dq	P	011	-16.2	16.2	6MDDR
pad_st_ck	P	011	-16.2	16.2	6MDDR

4.8.5 DC specification for CMOS090_ ddr library @ VDDE = 1.8 V

Table 30. DC electrical specifications for 1.8 V VDDE

Symbol		C	Parameter	Value		Unit	SpecID
				Min	Max		
Vdd	SR	P	Core supply voltage	1.08	1.32	V	D9.89
				1.08	1.47		
Vdde	SR	P	I/O supply voltage	1.7	1.9	V	D9.90
Vdd33	SR	P	I/O pre-driver supply voltage	3.0	3.6	V	D9.91
Vref	SR	P	Input reference voltage	$0.49 \times V_{dde}$	$0.51 \times V_{dde}$	V	D9.92
Vtt	SR	P	Termination voltage	$V_{ref} - 0.04$	$V_{ref} + 0.04$	V	D9.93
Vih	SR	P	Input high voltage	$V_{ref} + 0.125$	—	V	D9.94
Vil	SR	P	Input low voltage	—	$V_{ref} - 0.125$	V	D9.95
Voh	SR	P	Output high voltage	$V_{tt} + 0.81$	—	V	D9.96
Vol	SR	P	Output low voltage	—	$V_{tt} - 0.81$	V	D9.97

Table 31. Output drive current @ VDDE = 1.8 V (+/-100mV)

Pad		Drive mode	Minimum Ioh (mA)	Minimum Iol (mA)	Libraries
pad_st_acc	P	000	-3.57	3.57	6MDDR
		001	-7.84	7.84	
		010	-5.36	5.36	
		110	-13.4	13.4	
pad_st_dq	P	000	-3.57	3.57	6MDDR
		001	-7.84	7.84	
		010	-5.36	5.36	
		110	-13.4	13.4	
pad_st_clk	P	000	-3.57	3.57	6MDDR
		001	-7.84	7.84	
		010	-5.36	5.36	
		110	-13.4	13.4	

Table 32. ODT DC electrical characteristics

Symbol	C	Parameter	Condition	Value			Unit	SpecID	
				Min	Typ	Max			
Rtt	SR	C	Effective impedance value	Rainbow supports only 150 ohm termination and that can be enabled by enabling any bit of the termination control register (all of them are OR'ed).	120	150	180	Ω	D9.98

Table 33. core_v_det_odt and core_v_det33_odt specifications

VDDE	C	VDD	Vtrip max (V)	Vtrip min	Hysteresis min (V)
3.5	C	Rising	0.79	0.44	0.07
	C	Falling	0.56	0	
1.62	C	Rising	0.65	0.3	0.16
	C	Falling	0.33	0	
Rising	C	0.0	1.40	0.3	—

4.9 $\overline{\text{RESET}}$ electrical characteristics

The device implements a dedicated bidirectional RESET pin.

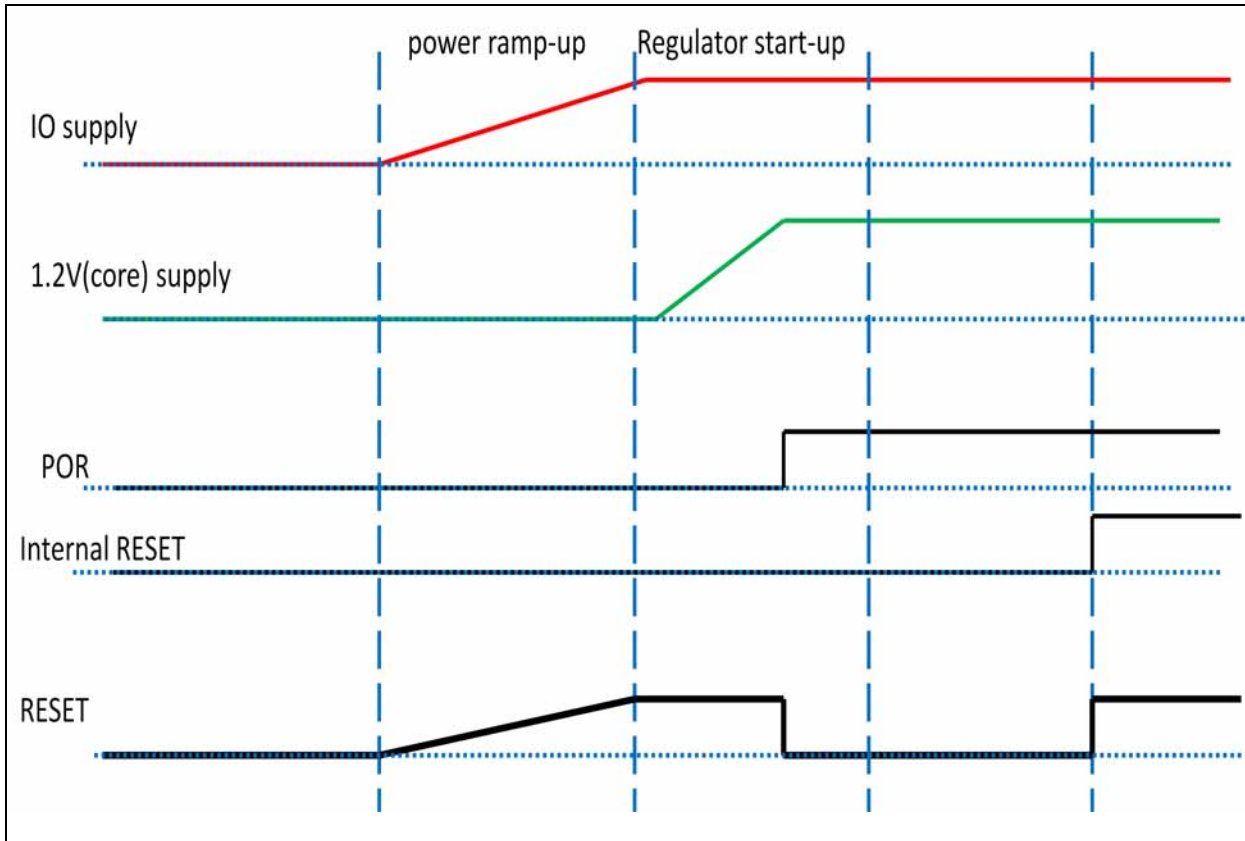

Figure 8. Start-up reset requirements

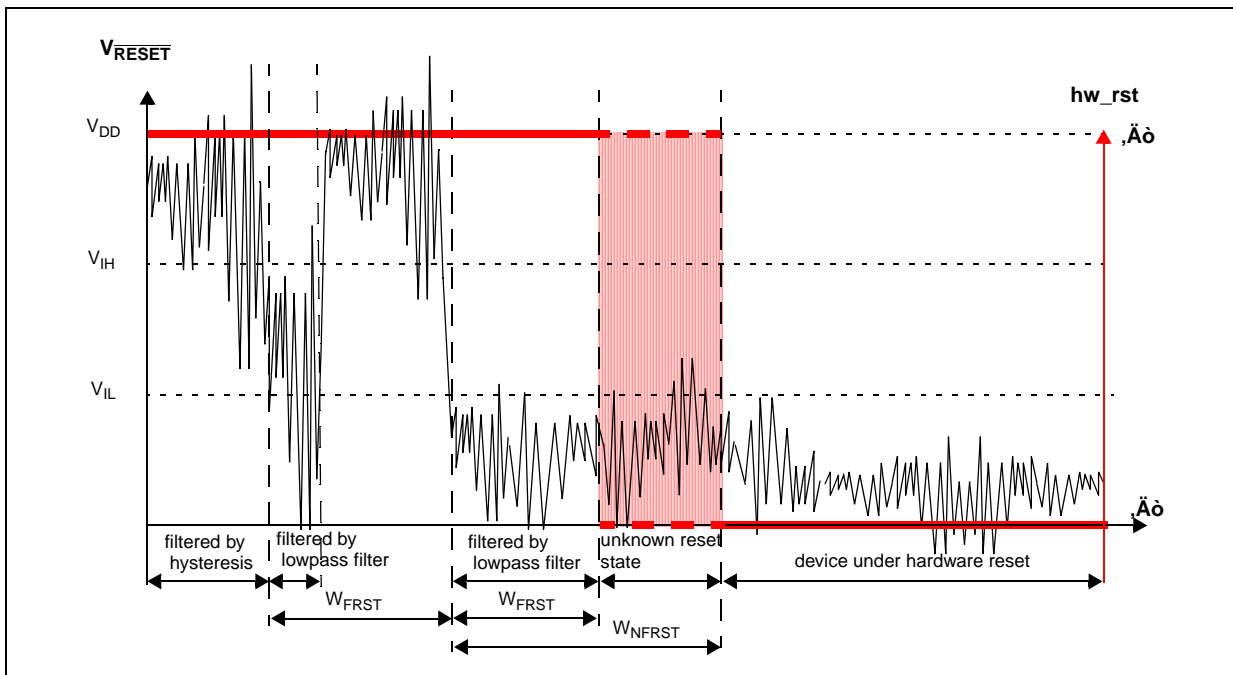

Figure 9. Noise filtering on reset signal

Table 34. Reset electrical characteristics

Symbol	C	Parameter	Conditions ¹	Value ²			Unit	SpecID	
				Min	Typ	Max			
V _{IH}	SR	P	Input High Level CMOS Schmitt Trigger	—	—	V _{DD} +0.4	V	D8.1	
V _{IL}	SR	P	Input low Level CMOS Schmitt Trigger	—	—	0.35V _{DD}	V	D8.2	
V _{HYS}	CC ³	D	Input hysteresis CMOS Schmitt Trigger	—	—	—	V	D8.3	
V _{OL}	CC ⁴	P	Output low level	Push Pull, I _{OL} = 2mA, V _{DD} = 5.0V ± 10%, ipp_hve = 0 (recommended)	—	—	0.1V _{DD}	V	D8.4
		D	Push Pull, I _{OL} = 1mA, V _{DD} = 5.0V ± 10%, ipp_hve = 1 ⁵	—	—	0.1V _{DD}			
		C	Push Pull, I _{OL} = 1mA, V _{DD} = 3.3V ± 10%, ipp_hve = 1 (recommended)	—	—	0.5			
T _{tr}	CC ⁴	T	Output transition time output pin ⁶ MEDIUM configuration	C _L = 25pF, V _{DD} = 5.0V ± 10%, ipp_hve = 0	—	—	10	ns	D8.5
				C _L = 50pF, V _{DD} = 5.0V ± 10%, ipp_hve = 0	—	—	20		
				C _L = 100pF, V _{DD} = 5.0V ± 10%, ipp_hve = 0	—	—	40		
				C _L = 25pF, V _{DD} = 3.3V ± 10%, ipp_hve = 1	—	—	12		
				C _L = 50pF, V _{DD} = 3.3V ± 10%, ipp_hve = 1	—	—	25		
				C _L = 100pF, V _{DD} = 3.3V ± 10%, ipp_hve = 1	—	—	40		
W _{FRST}	SR	P	$\overline{\text{RESET}}$ Input Filtered Pulse	—	—	70	ns	D8.6	
W _{NFRST}	SR	P	$\overline{\text{RESET}}$ Input Not Filtered Pulse	—	400	—	ns	D8.7	
I _{WPUL}	CC ⁴	P	Weak pull-up current absolute value	—	10	—	μA	D8.8	

¹ V_{DD} = 3.3V ± 10% / 5.0V ± 10%, T_A = -40 / +105°C, unless otherwise specified

² All values need to be confirmed during device validation.

³ Data based on characterization results, not tested in production

Electrical characteristics

- ⁴ Guaranteed by design simulation.
⁵ This is a transient configuration during power-up, up to the end of reset PHASE2 (refer to RGM module section of the reference manual).
⁶ C_L calculation should include device and package capacitance ($C_{PKG} < 5\text{pF}$).

4.10 Fast external crystal oscillator (4–16 MHz) electrical characteristics

This device implements the fast external oscillator (FXOSC) using a low power Loop Controlled Pierce Oscillator (LCP) configuration.

Table 35. Fast external crystal oscillator electrical characteristics

Symbol		Parameter	Conditions	Value			Unit	SpecID
				Min	Typ	Max		
f_{OSC}	C	Crystal oscillator range	Loop controlled Pierce	4.0		16	MHz	O9.1
i_{OSC}	P	Startup current		100			μA	O9.2
t_{UPOSC}	C	Oscillator start-up time	Loop controlled Pierce		4 ¹	50 ²	ms	O9.3
t_{CQOUT}	D	Clock quality check time-out		0.45		2.5	s	O9.4
f_{CMFA}	D	Clock monitor failure assert frequency		200	400	800	kHz	O9.5
f_{EXT}	D	External square wave input frequency ²		2.0		50	MHz	O9.6
t_{EXTL}	D	External square wave pulse width low		9.5			ns	O9.7
t_{EXTH}	D	External square wave pulse width high		9.5			ns	O9.8
t_{EXTR}	D	External square wave rise time				1	ns	O9.9
t_{EXTF}	D	External square wave fall time				1	ns	O9.10
C_{IN}	D	Input capacitance	EXTAL and XTAL pins		7		pF	O9.11
$V_{IH,EXTAL}$	P	EXTAL pin input high voltage ²		$0.75 \times V_{DDPLL}$			V	O9.12
	T					$V_{DDPLL} + 0.3$		
$V_{IL,EXTAL}$	P	EXTAL pin input low voltage ²				$0.25 \times V_{DDPLL}$	V	O9.13
	T			$V_{SSPLL} - 0.3$				
$V_{HYS,EXTAL}$	C	EXTAL pin input hysteresis ²			180		mV	O9.14
$V_{PP,EXTAL}$	C	EXTAL pin oscillation amplitude	Loop controlled Pierce		1.0		V	O9.15

¹ $f_{OSC} = 4\text{ MHz}$, $C = 22\text{ pF}$

² Maximum value is for extreme cases using high Q, low frequency crystals

4.11 Slow external crystal oscillator (32 KHz) electrical characteristics

The device provides a slow external oscillator/resonator driver (SXOSC).

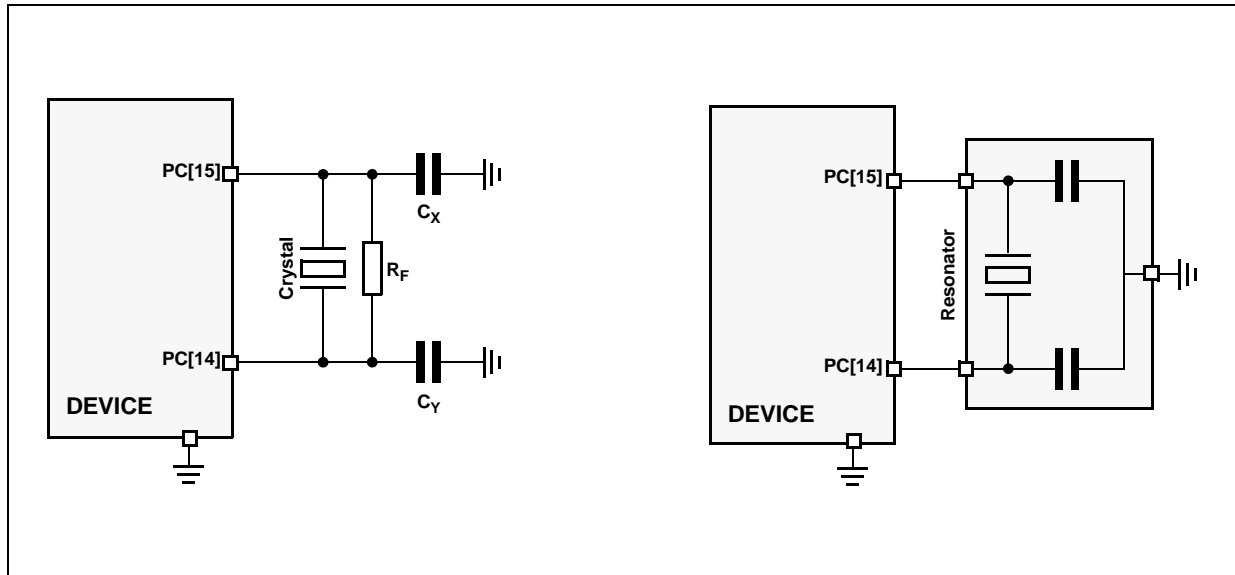

Figure 10. Crystal oscillator and resonator connection scheme

NOTE

PC[14]/PC[15] must not be directly used to drive external circuits.

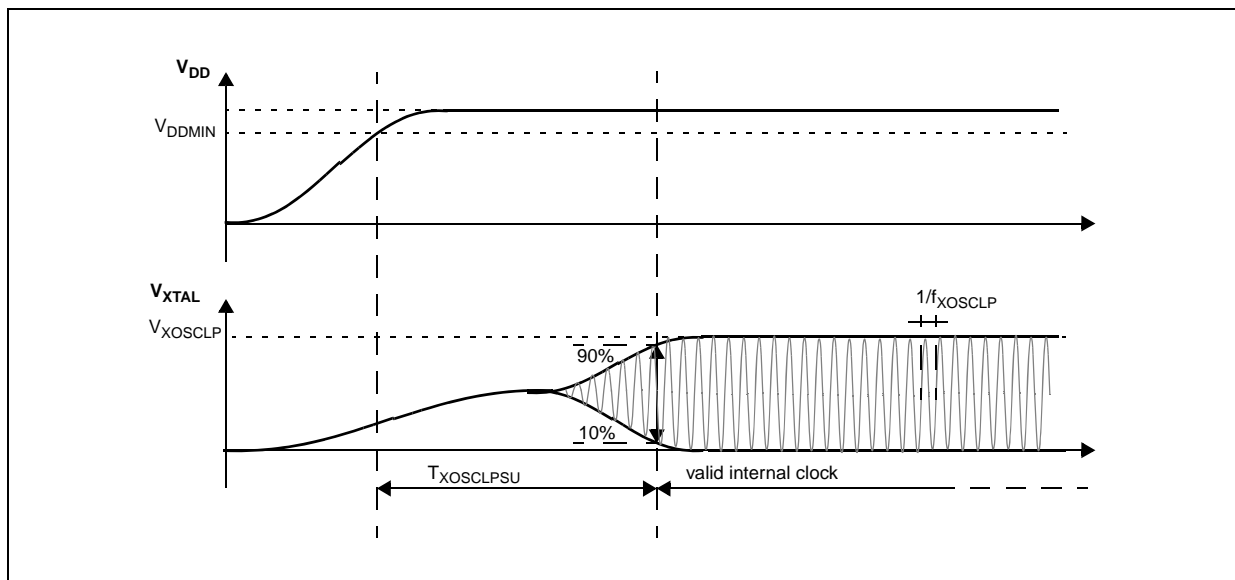

Figure 11. Slow external crystal oscillator electrical characteristics

Table 36. Slow external crystal oscillator electrical characteristics

Symbol		C	Parameter	Conditions ¹	Value ²			Unit	SpecID
					Min	Typ	Max		
f _{XOSCLP}	SR	C	Oscillator frequency		32	—	40	kHz	O10.1
V _{XOSCLP}	CC ³	C	Oscillation amplitude	V _{DDA} =3.3V±10%, V _{DDE_A} =3.3V±10%	1.12	1.33	1.74	V	O10.2
				V _{DDA} =5.0V±10%, V _{DDE_A} =5.0V±10%	1.12	1.37	1.74		
I _{XOSCLP}	CC ³	D	Oscillator consumption		—	—	5	µA	O10.3
T _{XOSCLPS U}	CC ³	D	Oscillator start-up time		—	—	2	s	O10.4
V _{IH}	SR	C	Input high level CMOS Schmitt Trigger	Oscillator bypass mode	0.65V _{DDA} 0.65V _{DDE_A}	—	V _{DDA} +0.4 V _{DDE_A} +0.4	V	O10.5
V _{IL}	SR	C	Input low level CMOS Schmitt Trigger	Oscillator bypass mode	V _{SS} -0.4	—	0.35V _{DDA} 0.35V _{DDE_A}	V	O10.6

¹ V_{DD} = 3.3 V ± 10% / 5.0 V ± 10%, T_A = -40 to +105 °C, unless otherwise specified

² All values need to be confirmed during device validation.

³ Granted by device validation

4.12 FMPLL electrical characteristics

The device provides a frequency-modulated phase-locked loop (FMPLL) module to generate a fast system clock from the fast external oscillator driver.

Table 37. FMPLL electrical characteristics

Symbol		C	Parameter	Conditions ¹	Value ²			Unit	SpecID
					Min	Typ	Max		
f _{PLLIN}	SR	T	PLL reference clock ³		4	—	120	MHz	O11.1
Δ _{PLLIN}	SR	T	PLL reference clock duty cycle ³		47.5	—	52.5	%	O11.2
f _{PLLOUT}	CC ⁴	T	PLL output clock frequency		15	—	250 ⁵	MHz	O11.3
f _{CPU}	CC ⁴	T	System clock frequency		—	—	125 ⁶	MHz	O11.4
T _{LOCK}	CC ⁴	T	PLL lock time	Stable oscillator (f _{PLLIN} = 10 MHz)	—	—	100	µs	O11.5
ΔT _{PKJIT}	CC ⁴	T	PLL jitter	f _{PLLOUT} (PHI i.e. FMPLL O/P) = 15.625 MHz @ 10 MHz resonator	-509	—	509	ps	O11.6
ΔT _{LTJIT}	CC ⁴	T	PLL long term jitter	f _{PLLIN} = 10 MHz (resonator)	-2.4	—	2.4	ns	O11.7
I _{PLL}	CC ⁷	D	Current Consumption (Normal Mode for Analog Supply)	T _A = 25°C	—	—	500	µA	O11.8

¹ V_{DDPLL} = 1.2 V ± 10%, T_A = -40 to +105 °C, unless otherwise specified.

² All values need to be confirmed during device validation.

³ PLLIN clock retrieved directly from XOSCHS clock. Input characteristics are granted when oscillator is used in functional mode. When bypass mode is used, oscillator input clock should verify f_{PLLIN} and Δ_{PLLIN}.

- ⁴ Data based on device simulation.
⁵ 2x sys clock required for generation of DDR timing.
⁶ f_{CPU} of 125 MHz can be achieved only at temperatures up to 105 °C with a maximum FM depth of 2%.
⁷ Data based on characterization results, not tested in production

4.13 Fast internal RC oscillator (16 MHz) electrical characteristics

The device provides a fast internal RC oscillator (FIRC). This is used as the default clock at the power-up of the device.

Table 38. Fast internal oscillator electrical characteristics

Symbol	C	Parameter	Conditions ¹	Value ²			Unit	SpecID	
				Min	Typ	Max			
f_{RCM}	CC ³	P	RC oscillator high frequency	$T_A = 25\text{ °C}$, trimmed		16		MHz	O12.1
I_{RCMRUN}	CC ³	D	RC oscillator high frequency current in running mode	$T_A = 25\text{ °C}$, trimmed			200	μA	O12.2
I_{RCMPWD}	CC ³	D	RC oscillator high frequency current in power down mode	$T_A = 25\text{ °C}$			10	μA	O12.3
$\Delta\text{RCMT-RIM}$	CC ³	C	RC oscillator precision after trimming of f_{RC}	$T_A = 25\text{ °C}$	-1		+1	%	O12.4
ΔRCMVAR	CC ⁴	C	RC oscillator variation in temperature and supply with respect to f_{RC} at $T_A = 55\text{ °C}$ in high-frequency configuration		-5		+5	%	O12.5

¹ $V_{DD} = 3.3\text{ V} \pm 10\% / 5.0\text{ V} \pm 10\%$, $T_A = -40$ to $+105\text{ °C}$, unless otherwise specified.

² All values need to be confirmed during device validation.

³ Guaranteed by device simulation, not tested in production

⁴ Guaranteed by device characterization, not tested in production

4.14 Slow internal RC oscillator (128 kHz) electrical characteristics

The device provides a slow internal RC oscillator (SIRC). This can be used as the reference clock for the RTC module.

Table 39. Slow internal RC oscillator electrical characteristics

Symbol	C	Parameter	Conditions ¹	Value ²			Unit	SpecID	
				Min	Typ	Max			
f_{RCL}	CC ³	P	RC oscillator low frequency	$T_A = 25\text{ °C}$, trimmed		128		kHz	O13.1
I_{RCL}	CC ³	D	RC oscillator low frequency current	$T_A = 25\text{ °C}$, trimmed			5	μA	O13.2
$\Delta\text{RCLT-RIM}$	CC ³	C	RC oscillator precision after trimming of f_{RCL}	$T_A = 25\text{ °C}$	-2		+2	%	O13.3
ΔRCLVAR ₃	CC ³	C	RC oscillator variation in temperature and supply with respect to f_{RC} at $T_A = 55\text{ °C}$ in high frequency configuration	High frequency configuration	-10		+10	%	O13.4

¹ $V_{DD} = 3.3\text{ V} \pm 10\% / 5.0\text{ V} \pm 10\%$, $T_A = -40$ to $+105\text{ °C}$, unless otherwise specified.

² All values need to be confirmed during device validation.

³ Guaranteed by device simulation, not tested in production

4.15 Flash memory electrical characteristics

Table 40. Program and erase specifications

Symbol	C	Parameter	Min Value	Typical Value ¹	Initial Max ²	Max ³	Unit	SpecID
T _{dwprogram}	C	Double Word (64 bits) Program Time ⁴		—	22	500	μs	D14.1
T _{16kpperase}	C	16 KB Block Pre-program and Erase Time		—	500	5000	ms	D14.2
T _{32kpperase}	C	32 KB Block Pre-program and Erase Time		—	600	5000	ms	D14.3
T _{128kpperase}	C	128 KB Block Pre-program and Erase Time		—	1300	7500	ms	D14.4

¹ Typical program and erase times assume nominal supply values and operation at 25 °C. All times are subject to change pending device characterization.

² Initial factory condition: < 100 program/erase cycles, 25 °C, typical supply voltage.

³ The maximum program & erase times occur after the specified number of program/erase cycles. These maximum values are characterized but not guaranteed.

⁴ Actual hardware programming times. This does not include software overhead.

Table 41. Flash module life

Symbol	C	Parameter	Conditions	Value		Unit	SpecID
				Min	Typ		
P/E	C	Number of program/erase cycles per block for 16 KB, 48KB and 64KB blocks, across full operating temperature range (T _j)	—	100,000	—	P/E cycles	D14.5
P/E	C	Number of program/erase cycles per block for 128KB and 256KB blocks, across full operating temperature range (T _j)	—	1,000	100,000	P/E cycles	D14.6
Data retention	C	Minimum data retention at 85 °C average ambient temperature ¹	Blocks with 0 - 1,000 P/E cycles	20	—	Years	D14.8
			Blocks with 1,001 - 10,000 P/E cycles	10	—	Years	
			Blocks with 10,001 - 100,000 P/E cycles	5	—	Years	

¹ Ambient temperature averaged over duration of application, not to exceed recommended product operating temperature range.

4.16 ADC parameters

The device provides a 10-bit Successive Approximation Register (SAR) Analog to Digital Converter.

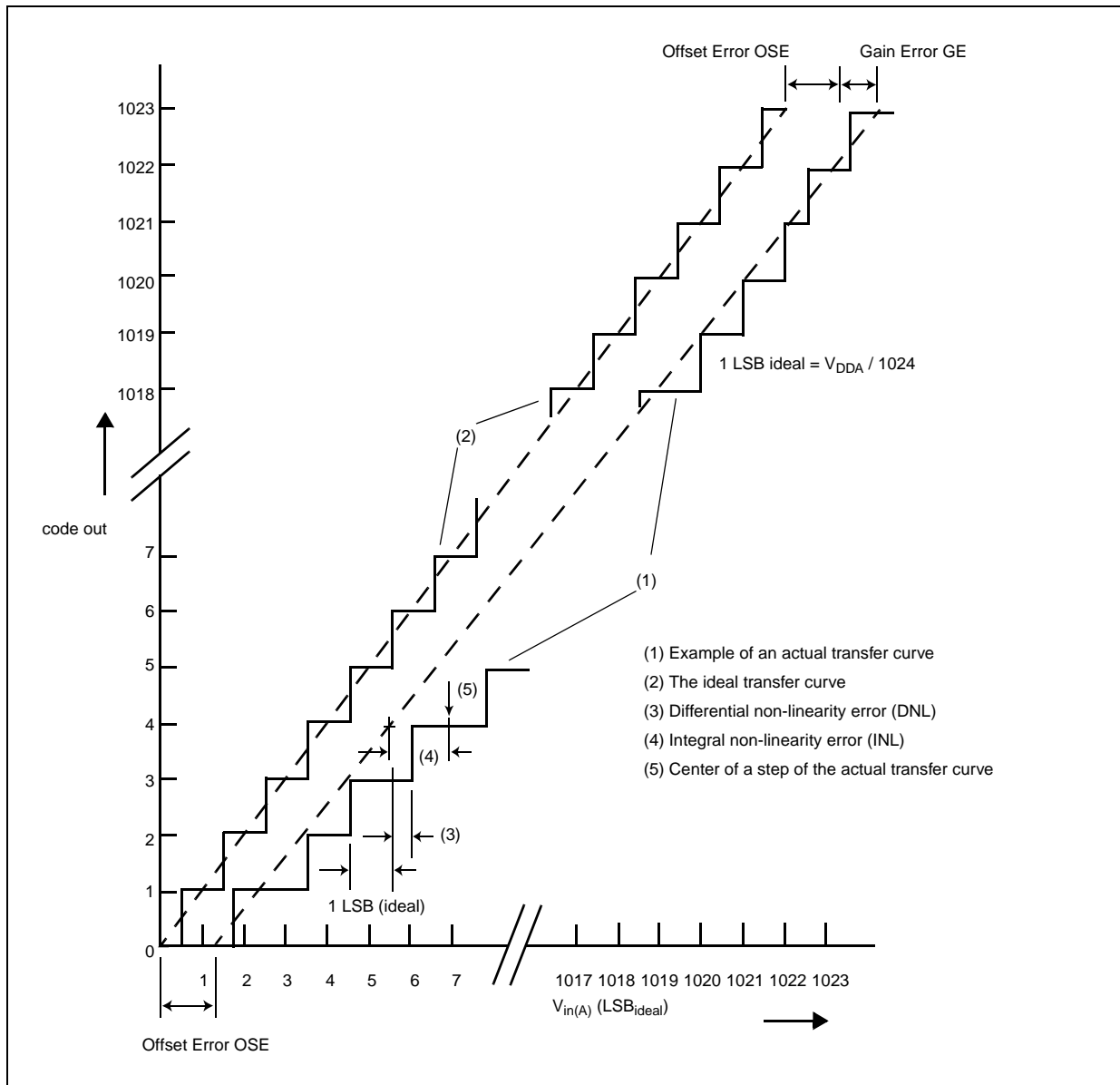

Figure 12. ADC Characteristics and Error Definitions

4.16.1 Input Impedance and ADC Accuracy

In the following analysis, the input circuit corresponding to the precise channels is considered.

To preserve the accuracy of the A/D converter, it is necessary that analog input pins have low AC impedance. Placing a capacitor with good high frequency characteristics at the input pin of the device can be effective: the capacitor should be as large as possible, ideally infinite. This capacitor contributes to attenuating the noise present on the input pin; furthermore, it sources charge during the sampling phase, when the analog signal source is a high-impedance source.

A real filter can typically be obtained by using a series resistance with a capacitor on the input pin (simple RC filter). The RC filtering may be limited according to the value of source impedance of the transducer or circuit supplying the analog signal to be measured. The filter at the input pins must be designed taking into account the dynamic characteristics of the input signal (bandwidth) and the equivalent input impedance of the ADC itself.

Electrical characteristics

In fact a current sink contributor is represented by the charge sharing effects with the sampling capacitance: C_S being substantially a switched capacitance, with a frequency equal to the conversion rate of the ADC, it can be seen as a resistive path to ground. For instance, assuming a conversion rate of 1 MHz, with C_S equal to 3 pF, a resistance of 330k Ω is obtained ($R_{EQ} = 1 / (f_c * C_S)$, where f_c represents the conversion rate at the considered channel). To minimize the error induced by the voltage partitioning between this resistance (sampled voltage on C_S) and the sum of $R_S + R_F + R_L + R_{SW} + R_{AD}$, the external circuit must be designed to respect the [Equation 5](#):

Eqn. 5

$$V_A \cdot \frac{R_S + R_F + R_L + R_{SW} + R_{AD}}{R_{EQ}} < \frac{1}{2} \text{LSB}$$

[Equation 5](#) generates a constraint for external network design, in particular on resistive path. Internal switch resistances (R_{SW} and R_{AD}) can be neglected with respect to external resistances.

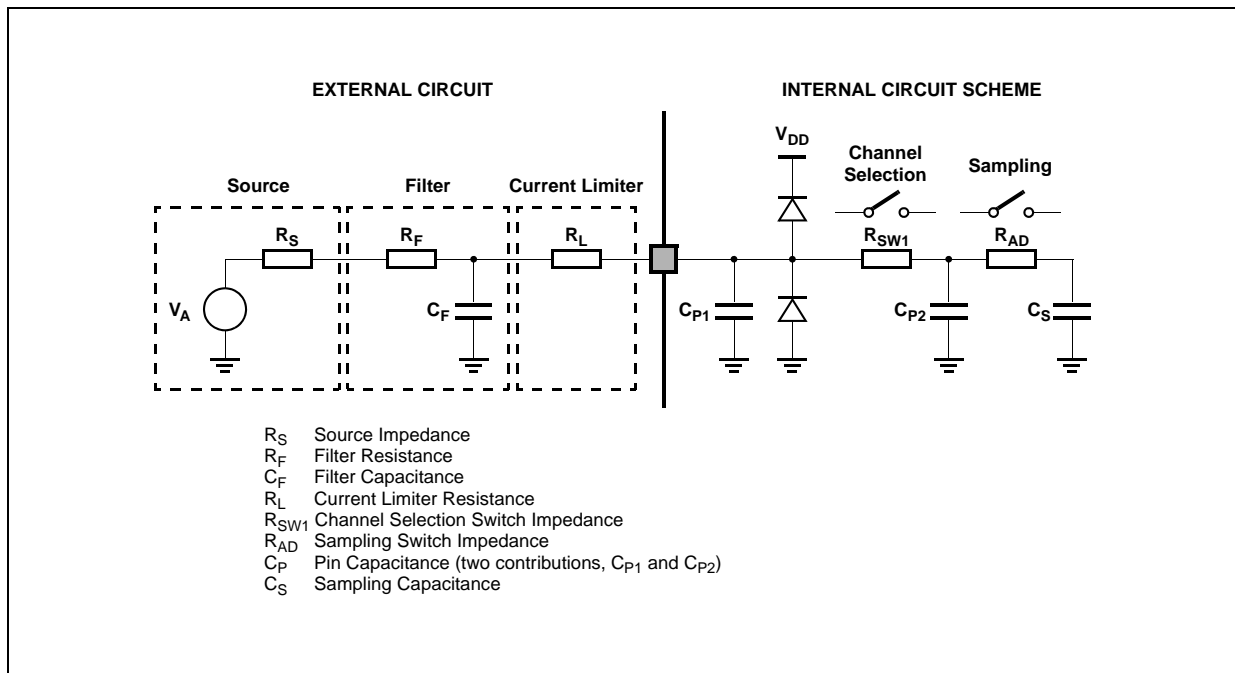

Figure 13. Input Equivalent Circuit (Precise Channels)

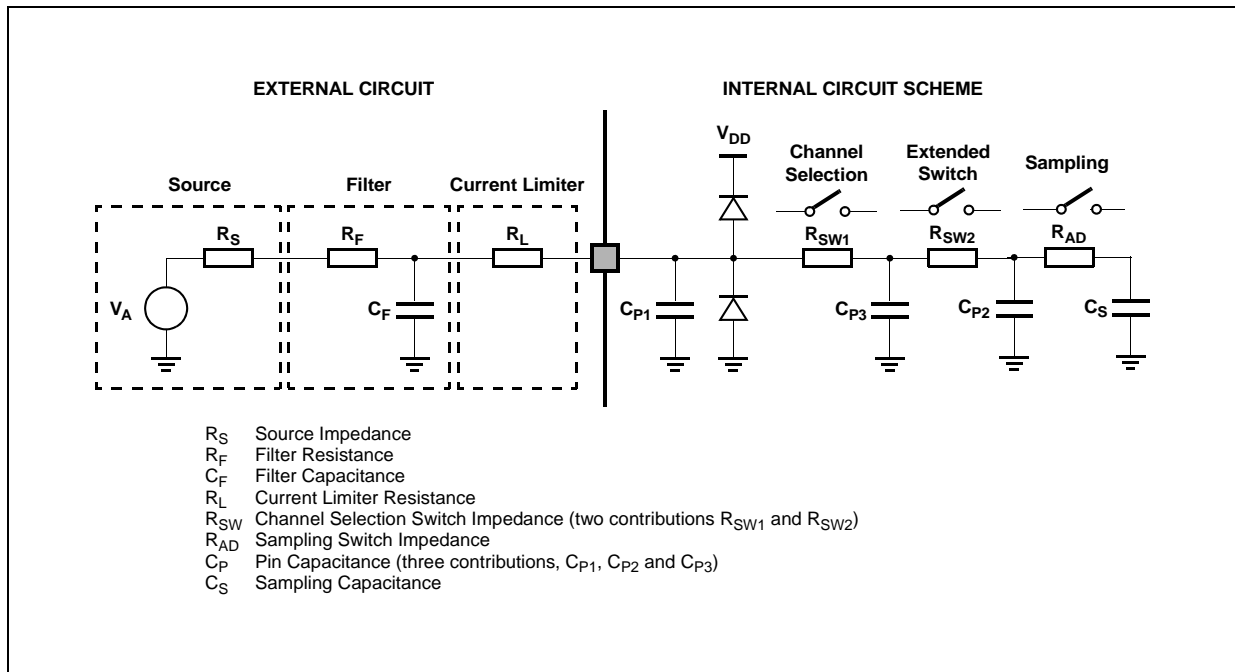

Figure 14. Input Equivalent Circuit (Extended Channels)

A second aspect involving the capacitance network shall be considered. Assuming the three capacitances C_F , C_{P1} and C_{P2} are initially charged at the source voltage V_A (refer to the equivalent circuit reported in Figure 13): A charge sharing phenomenon is installed when the sampling phase is started (A/D switch close).

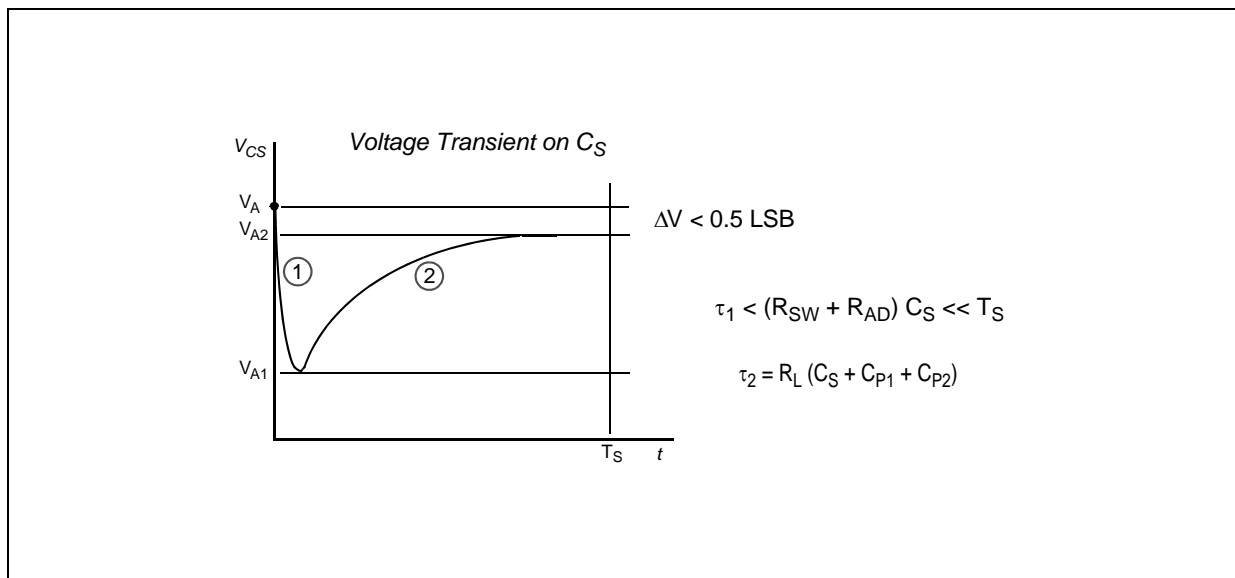

Figure 15. Transient Behavior during Sampling Phase

In particular two different transient periods can be distinguished:

- A first and quick charge transfer from the internal capacitance C_{P1} and C_{P2} to the sampling capacitance C_S occurs (C_S is supposed initially completely discharged): considering a worst case (since the time constant in reality would be faster) in which C_{P2} is reported in parallel to C_{P1} (call $C_P = C_{P1} + C_{P2}$), the two capacitances C_P and C_S are in series, and the time constant is

Eqn. 6

$$\tau_1 = (R_{SW} + R_{AD}) \cdot \frac{C_P \cdot C_S}{C_P + C_S}$$

Equation 6 can again be simplified considering only C_S as an additional worst condition. In reality, the transient is faster, but the A/D converter circuitry has been designed to be robust also in the very worst case: the sampling time T_S is always much longer than the internal time constant:

Eqn. 7

$$\tau_1 < (R_{SW} + R_{AD}) \cdot C_S \ll T_S$$

The charge of C_{P1} and C_{P2} is redistributed also on C_S , determining a new value of the voltage V_{A1} on the capacitance according to Equation 8:

Eqn. 8

$$V_{A1} \cdot (C_S + C_{P1} + C_{P2}) = V_A \cdot (C_{P1} + C_{P2})$$

- A second charge transfer involves also C_F (that is typically bigger than the on-chip capacitance) through the resistance R_L : again considering the worst case in which C_{P2} and C_S were in parallel to C_{P1} (since the time constant in reality would be faster), the time constant is:

Eqn. 9

$$\tau_2 < R_L \cdot (C_S + C_{P1} + C_{P2})$$

In this case, the time constant depends on the external circuit: in particular imposing that the transient is completed well before the end of sampling time T_S , a constraints on R_L sizing is obtained:

Eqn. 10

$$10 \cdot \tau_2 = 10 \cdot R_L \cdot (C_S + C_{P1} + C_{P2}) < T_S$$

Of course, R_L shall be sized also according to the current limitation constraints, in combination with R_S (source impedance) and R_F (filter resistance). Being C_F definitively bigger than C_{P1} , C_{P2} and C_S , then the final voltage V_{A2} (at the end of the charge transfer transient) will be much higher than V_{A1} . Equation 11 must be respected (charge balance assuming now C_S already charged at V_{A1}):

Eqn. 11

$$V_{A2} \cdot (C_S + C_{P1} + C_{P2} + C_F) = V_A \cdot C_F + V_{A1} \cdot (C_{P1} + C_{P2} + C_S)$$

The two transients above are not influenced by the voltage source that, due to the presence of the $R_F C_F$ filter, is not able to provide the extra charge to compensate the voltage drop on C_S with respect to the ideal source V_A ; the time constant $R_F C_F$ of the filter is very high with respect to the sampling time (T_S). The filter is typically designed to act as anti-aliasing.

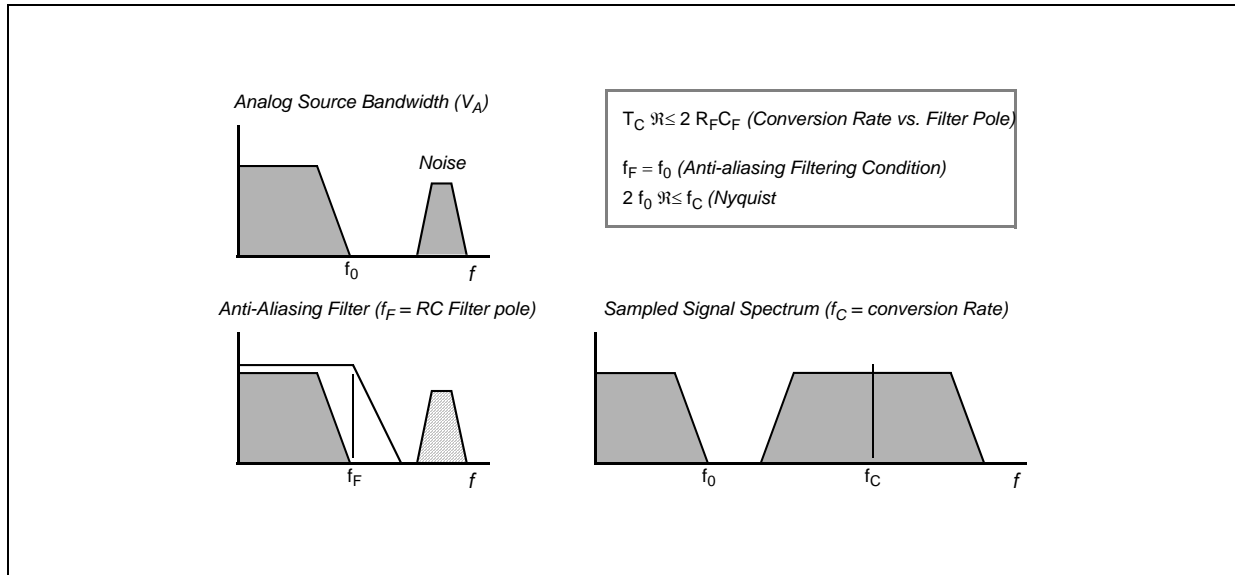

Figure 16. Spectral Representation of Input Signal

Calling f_0 the bandwidth of the source signal (and as a consequence the cut-off frequency of the anti-aliasing filter, f_F), according to the Nyquist theorem the conversion rate f_C must be at least $2f_0$; it means that the constant time of the filter is greater than or at least equal to twice the conversion period (T_C). Again the conversion period T_C is longer than the sampling time T_S , which is just a portion of it, even when fixed channel continuous conversion mode is selected (fastest conversion rate at a specific channel): in conclusion it is evident that the time constant of the filter $R_F C_F$ is definitively much higher than the sampling time T_S , so the charge level on C_S cannot be modified by the analog signal source during the time in which the sampling switch is closed.

The considerations above lead to impose new constraints on the external circuit, to reduce the accuracy error due to the voltage drop on C_S ; from the two charge balance equations above, it is simple to derive Equation 12 between the ideal and real sampled voltage on C_S :

Eqn. 12

$$\frac{V_A}{V_{A2}} = \frac{C_{P1} + C_{P2} + C_F}{C_{P1} + C_{P2} + C_F + C_S}$$

From this formula, in the worst case (when V_A is maximum, that is for instance 5V), assuming to accept a maximum error of half a count, a constraint is evident on C_F value:

Eqn. 13

$$C_F > 2048 \cdot C_S$$

4.16.2 ADC electrical characteristics

Table 42. ADC electrical characteristics

Symbol		C	Parameter	Conditions ¹	Value ²			Unit	SpecID
					Min	Typ	Max		
V _{SSA}	SR	D	Voltage on VSSA (ADC reference) pin with respect to ground (V _{SS}) ³		-0.1		0.1	V	D15.1
V _{DDA}	SR	D	Voltage on VDDA pin (ADC reference) with respect to ground (V _{SS})		V _{DDE_A} -0.1		V _{DDE_A} +0.1	V	D15.2
V _{AINx}	SR	D	Analog input voltage ⁴		V _{SSA} -0.1		V _{DDA} +0.1	V	D15.3
f _{ADC}	SR	D	ADC analog frequency		6		32	MHz	D15.4
t _{ADC_PU}	SR	D	ADC power up delay				1.5	μs	D15.5
t _{ADC_S}	CC ⁵	T	Sample time ⁶	f _{ADC} = 32 MHz, ADC_conf_sample_input = 17	0.5		21	μs	D15.6
				f _{ADC} = 6 MHz, ADC_conf_sample_input = 127					
t _{ADC_C}	CC ⁵	T	Conversion time ⁷	f _{ADC} = 32 MHz, ADC_conf_comp = 2	0.625			μs	D15.7
C _S	CC ⁵	D	ADC input sampling capacitance				3	pF	D15.8
C _{P1}	CC ⁵	D	ADC input pin capacitance 1				3	pF	D15.9
C _{P2}	CC ⁵	D	ADC input pin capacitance 2				1	pF	D15.10
C _{P3}	CC ⁵	D	ADC input pin capacitance 3				1	pF	D15.11
R _{SW1}	CC ⁵	D	Internal resistance of analog source				3	kΩ	D15.12
R _{SW2}	CC ⁵	D	Internal resistance of analog source				2	kΩ	D15.13
R _{AD}	CC ⁵	D	Internal resistance of analog source				0.1	kΩ	D15.14
I _{INJ}	SR	T	Input current Injection	Current injection on one ADC input, different from the converted one	-10		10	mA	D15.15
INL	CC ⁵	P	Integral Non Linearity	No overload	-1.5		1.5	LSB	D15.16
DNL	CC ⁵	P	Differential Non Linearity	No overload	-1.0		1.0	LSB	D15.17
OFS	CC ⁵	T	Offset error	After offset cancellation	-1.0		1.0	LSB	D15.18
GNE	CC ⁵	T	Gain error		-1.0		1.0	LSB	D15.19

Table 42. ADC electrical characteristics (continued)

Symbol	C	Parameter	Conditions ¹	Value ²			Unit	SpecID	
				Min	Typ	Max			
TUEX	CC	T	Total Unadjusted Error for extended channel	No overload	-3		3	LSB	D15.21
TUEP	CC ⁵	T	Total Unadjusted Error for precise channels, input only pins	No overload	-2		2	LSB	D15.22
				overload conditions on adjacent channel				LSB	
TUEX	CC ⁵	T	Total Unadjusted Error for extended channel,	No overload	-3		3	LSB	D15.23
				overload conditions on adjacent channel				LSB	

¹ $V_{DDA} = 3.3\text{ V} \pm 10\% / 5.0\text{ V} \pm 10\%$, $T_A = -40$ to $+105\text{ }^\circ\text{C}$, unless otherwise specified.

² All values need to be confirmed during device validation.

³ Analog and digital V_{SS} **must** be common (to be tied together externally).

⁴ V_{AINx} may exceed V_{SSA} and V_{DDA} limits, remaining on absolute maximum ratings, but the results of the conversion will be clamped respectively to 0x000 or 0x3FF

⁵ Guaranteed by design

⁶ During the sample time the input capacitance C_S can be charged/discharged by the external source. The internal resistance of the analog source must allow the capacitance to reach its final voltage level within t_{ADC_S} . After the end of the sample time t_{ADC_S} , changes of the analog input voltage have no effect on the conversion result. Values for the sample clock t_{ADC_S} depend on programming.

⁷ This parameter does not include the sample time t_{ADC_S} , but only the time for determining the digital result and the time to load the result's register with the conversion result.

4.17 AC specifications

4.17.1 AC specification for CMOS090LP2 library @ VDDE = 3.3 V

Table 43. Functional pad type AC specifications

Name	C	Prop. delay (ns) $L>H / H>L$ ¹		Rise/fall edge (ns)		Drive load (pF)	Drive/slew rate select
		Min	Max	Min	Max		MSB, LSB
pad_ssr	C	—	4.5 / 4.5	—	2.2 / 2.2	50	11 ²
		—	8 / 8	—	6 / 6	200	
		—	45 / 45	—	22 / 22	50	10
		—	60 / 60	—	28 / 28	200	
		—	90 / 90	—	42 / 42	50	01
		—	110 / 110	—	50 / 50	200	
		—	430 / 430	—	210 / 210	50	00
		—	480 / 480	—	220 / 220	200	

Table 43. Functional pad type AC specifications (continued)

Name	C	Prop. delay (ns) L>H / H>L ¹		Rise/fall edge (ns)		Drive load (pF)	Drive/slew rate select
		Min	Max	Min	Max		MSB, LSB
pad_fc	C	—	2.5 / 2.5	—	1.2 / 1.2	10	00
		—	2.5 / 2.5	—	1.2 / 1.2	20	01
		—	2.5 / 2.5	—	1.2 / 1.2	30	10
		—	2.5 / 2.5	—	1.2 / 1.2	50	11 ²
pad_msr	C	—	4.0 / 4.5	—	1.02 / 1.4	50	11 ²
		—	7.3 / 8.3	—	3.5 / 4.2	200	
		—	24 / 22	—	9.1 / 10.3	50	10
		—	33 / 31	—	14 / 15	200	
		—	49 / 44	—	18 / 21	50	01
		—	60 / 53	—	24 / 25	200	
		—	332 / 302	—	126 / 151	50	00
		—	362 / 325	—	136 / 158	200	

¹ L>H signifies low-to-high propagation delay and H>L signifies high-to-low propagation delay.

² Can be used on the tester

4.17.2 AC specification for CMOS090LP2fg library @ VDDE = 5.0 V

Table 44. Functional pad type AC specifications

Name	C	Prop. delay (ns) L>H / H>L ¹		Rise/fall edge (ns)		Drive load (pF)	Drive/slew rate select	
		Min	Max	Min	Max		MSB, LSB	
pad_msr_hv ²	C	4.6 / 3.7	12 / 12	2.2 / 2.2	5.3 / 5.9	50	11 ³	
		13 / 10	32 / 32	9 / 9	22 / 22	200		
		N/A						10 ⁴
		12 / 13	28 / 34	5.6 / 6	12 / 15	50	01	
		23 / 23	52 / 59	11 / 14	28 / 31	200		
		69 / 71	152 / 165	34 / 35	70 / 74	50	00	
		95 / 90	205 / 220	44 / 51	96 / 96	200		

Table 44. Functional pad type AC specifications (continued)

Name	C	Prop. delay (ns) L>H / H>L ¹		Rise/fall edge (ns)		Drive load (pF)	Drive/slew rate select	
		Min	Max	Min	Max		MSB, LSB	
pad_ssr_hv ²	C	7.3 / 5.7	19 / 18	4.4 / 4.3	10 / 11	50	11 ³	
		24 / 19	58 / 58	17 / 15	40 / 42	200		
		N/A						10 ⁴
		26 / 27	61 / 69	13 / 13	30 / 34	50	01	
		49 / 45	115 / 115	27 / 23	61 / 61	200		
		137 / 142	320 / 330	72 / 74	156 / 164	50	00	
		182 / 172	420 / 420	90 / 85	200 / 200	200		
pad_i_hv	C	0.5 / 0.5	1.9 / 1.9	0.3 / 0.3	1.5 / 1.5	0.5	N/A	

¹ L>H signifies low-to-high propagation delay and H>L signifies high-to-low propagation delay.

² For input buffer timing, look at pad_i_hv.

³ Can be used on the tester

⁴ This drive select value is not supported. If selected, it will be approximately equal to 11.

4.17.3 AC specification for CMOS090LP2fg library @ VDDE = 3.3 V

Table 45. Functional pad AC type specifications

Name	Prop. delay (ns) L>H / H>L		Rise/fall edge (ns)		Drive load (pF)	Drive/slew rate select	
	Min	Max	Min	Max		MSB, LSB	
pad_msr_hv	5.8 / 4.4	18 / 17	2.7 / 2.1	7.6 / 8.5	50	11	
	16 / 13	46 / 49	11.2 / 8.6	30 / 34	200		
	N/A						10
	14 / 16	37 / 45	6.5 / 6.7	15.5 / 19	50	01	
	27 / 27	69 / 82	15 / 13	38 / 43	200		
	83 / 86	200 / 210	38 / 38	86 / 86	50	00	
	113 / 109	270 / 285	53 / 46	120 / 120	200		
pad_ssr_hv	9.2 / 6.9	27 / 28	5.5 / 4.1	15 / 17	50	11	
	30 / 23	81 / 87	21 / 16	57 / 63	200		
	N/A						10
	31 / 31	80 / 90	15.4 / 15.4	38 / 42	50	01	
	58 / 52	144 / 155	32 / 26	82 / 85	200		
	162 / 168	415 / 415	80 / 82	190 / 190	50	00	
	216 / 205	533 / 540	106 / 95	250 / 250	200		
pad_i_hv	0.5 / 0.5	3 / 3	0.4 / 0.4	1.5 / 1.5	0.5	N/A	

4.17.4 Pad AC specifications (3.3 V, PAD3V5V = 1)

Table 46. Pad AC specifications (3.3 V, PAD3V5V = 1)¹

No.	Pad	Tswitchon ¹ (ns)			Rise/Fall ² (ns)			Frequency (MHz)			Current slew (mA/ns)			Load drive (pF)
		Min	Typ	Max	Min	Typ	Max	Min	Typ	Max	Min	Typ	Max	
1	Slow	3	—	40	4	—	40	—	—	4	0.01	—	2	25
		3	—	40	6	—	50	—	—	2	0.01	—	2	50
		3	—	40	10	—	75	—	—	2	0.01	—	2	100
		3	—	40	14	—	100	—	—	2	0.01	—	2	200
2	Medium	1	—	15	2	—	12	—	—	40	2.5	—	7	25
		1	—	15	4	—	25	—	—	20	2.5	—	7	50
		1	—	15	8	—	40	—	—	13	2.5	—	7	100
		1	—	15	14	—	70	—	—	7	2.5	—	7	200
3	Fast	1	—	6	1	—	4	—	—	72	3	—	40	25
		1	—	6	1.5	—	7	—	—	55	3	—	40	50
		1	—	6	3	—	12	—	—	40	3	—	40	100
		1	—	6	5	—	18	—	—	25	3	—	40	200
4	Pull Up/Down (3.6 V max)	—	—	—	—	—	7500	—	—	—	—	—	—	50
Parameter Classification		D			C			C			C			n/a

¹ Propagation delay from $V_{DD}/2$ of internal signal to Pchannel/Nchannel on condition

² Slope at rising/falling edge

4.17.5 AC specification for CMOS090_dds library @ VDDE = 3.3 V

Table 47. AC specifications at 3.3 V VDDE

Name	C	Prop. delay (ns) L>H / H>L		Rise/fall edge (ns)		Drive load (pF)	Drive/slew rate select	Libraries
		Min	Max	Min	Max		MSB, LSB	
pad_st_acc	C	1.4/1.4	2.4/2.4	3.1/2.5	5.6/5.4	5	111	6MDDR
		1.7/1.7	2.7/2.7	0.9/1.1	1.7/2.0	20		
pad_st_dq	C	1.4/1.4	2.4/2.4	3.1/2.5	5.6/5.4	5	111	6MDDR
		1.7/1.7	2.7/2.7	0.9/1.1	1.7/2.0	20		
pad_st_clk	C	1.4/1.4	2.4/2.4	3.1/2.5	5.7/5.7	5	111	6MDDR
		1.6/1.6	2.6/2.6	1.1/1.3	2.3/2.3	20		

4.17.6 AC specification for CMOS090_dds library @ VDDE = 2.5 V

Table 48. AC specifications at 2.5 V VDDE

Name	C	Prop. delay (ns) L>H / H>L		Rise/fall edge (ns)		Drive load (pF)	Drive/slew rate select	Libraries
		Min	Max	Min	Max		MSB, LSB	
pad_st_acc	C	1.4/1.5	2.5/2.4	2.1/2.1	4.3/4.1	5	011	6MDDR
		1.7/1.7	2.8/2.7	0.6/0.7	1.1/1.3	20		
pad_st_dq	C	1.4/1.5	2.5/2.4	2.1/2.1	4.3/4.1	5	011	6MDDR
		1.7/1.7	2.8/2.7	0.6/0.7	1.1/1.3	20		
pad_st_clk	C	1.4/1.4	2.4/2.4	2.1/2.1	4.4/4.1	5	011	6MDDR
		1.1/1.6	2.7/2.7	0.6/0.7	1.6/1.8	20		

4.17.7 AC specification for CMOS090_dds library @ VDDE = 1.8 V

Table 49. AC electrical specifications at 1.8 V VDD

Name	C	Prop. delay (ns) L>H / H>L		Rise/fall edge (ns)		Drive load (pF)	Drive/slew rate select	Libraries
		Min	Max	Min	Max		MSB, LSB	
pad_st_acc	C	1.4/1.4	2.4/2.4	0.6/1.0	2.7/2.6	5	000	6MDDR
		1.7/1.7	2.8/2.7	0.2/0.4	0.5/0.6	20		
		1.4/1.5	2.4/2.5	1.1/1.1	3.0/2.7	5	001	
		1.7/1.7	2.8/2.8	0.4/0.4	0.7/0.7	20		
		1.4/1.5	2.4/2.4	1.0/1.1	2.9/2.7	5	010	
		1.7/1.7	2.8/2.7	0.3/0.4	0.6/0.7	20		
		1.4/1.5	2.5/2.5	1.5/1.1	3.1/2.6	5	110	
		1.7/1.8	2.8/2.8	0.4/0.4	0.7/0.6	20		
pad_st_dq	C	1.4/1.4	2.4/2.4	0.6/1.0	2.7/2.6	5	000	6MDDR
		1.7/1.7	2.8/2.7	0.2/0.4	0.5/0.6	20		
		1.4/1.5	2.4/2.5	1.1/1.1	3.0/2.7	5	001	
		1.7/1.7	2.8/2.8	0.4/0.4	0.7/0.7	20		
		1.4/1.5	2.4/2.4	1.0/1.1	2.9/2.7	5	010	
		1.7/1.7	2.8/2.7	0.3/0.4	0.6/0.7	20		
		1.4/1.5	2.5/2.5	1.5/1.1	3.1/2.6	5	110	
		1.7/1.8	2.8/2.8	0.4/0.4	0.7/0.6	20		

Table 49. AC electrical specifications at 1.8 V VDD (continued)

Name	C	Prop. delay (ns) L>H / H>L		Rise/fall edge (ns)		Drive load (pF)	Drive/slew rate select	Libraries
		Min	Max	Min	Max		MSB, LSB	
pad_st_clk	C	1.4/1.4	2.4/2.4	0.4/0.6	2.7/2.7	5	000	6MDDR
		1.6/1.6	2.7/2.7	0.7/0.9	1.8/3.4	20		
		1.4/1.4	2.4/2.4	1.1/1.1	3.0/2.8	5	001	
		1.7/1.7	2.7/2.7	0.3/0.4	1.0/1.1	20		
		1.4/1.4	2.4/2.4	0.9/1.1	3.0/2.8	5	010	
		1.6/1.6	2.7/2.7	0.3/0.4	0.9/1.0	20		
		1.4/1.5	2.5/2.5	1.5/1.2	3.2/2.6	5	110	
		1.7/1.8	2.7/2.7	0.4/0.4	1.1/1.2	20		

4.18 AC timing

4.18.1 IEEE 1149.1 interface timing

Table 50. JTAG interface timing¹

Num	Symbol	C	Characteristic	Min	Max	Unit	SpecID
1	t _{JCYC}	CC ²	D TCK Cycle Time	100	—	ns	A1.1
2	t _{JDC}	CC ²	D TCK Clock Pulse Width (Measured at V _{DD} /2)	40	60	ns	A1.2
3	t _{TCKRISE}	CC ²	D TCK Rise and Fall Times (40% – 70%)	—	3	ns	A1.3
4	t _{TMSS} , t _{TDIS}	CC ²	D TMS, TDI Data Setup Time	5	—	ns	A1.4
5	t _{TMSH} , t _{TDIH}	CC ²	D TMS, TDI Data Hold Time	25	—	ns	A1.5
6	t _{TDOV}	CC ²	D TCK Low to TDO Data Valid	—	35	ns	A1.6
7	t _{TDOI}	CC ²	D TCK Low to TDO Data Invalid	0	—	ns	A1.7
8	t _{TDOHZ}	CC ²	D TCK Low to TDO High Impedance	—	30	ns	A1.8
9	t _{BSDV}	CC ²	D TCK Falling Edge to Output Valid	—	35	ns	A1.9
10	t _{BSDVZ}	CC ²	D TCK Falling Edge to Output Valid out of High Impedance	—	50	ns	A1.10
11	t _{BSDHZ}	CC ²	D TCK Falling Edge to Output High Impedance	—	50	ns	A1.11
12	t _{BSDST}	CC ²	D Boundary Scan Input Valid to TCK Rising Edge	50	—	ns	A1.12
13	t _{BSDHT}	CC ²	D TCK Rising Edge to Boundary Scan Input Invalid	50	—	ns	A1.13

¹ These specifications apply to JTAG boundary scan only. JTAG timing specified at V_{DD} = 3.0 V to 3.6 V, T_A = -40 to 105 °C, and CL = 50 pF with SRC = 0b01.

² Parameter values guaranteed by design.

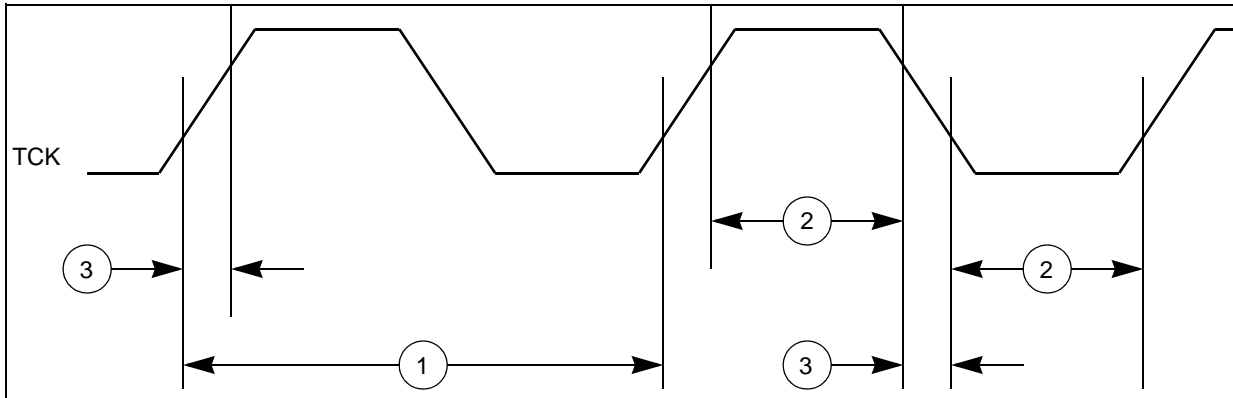

Figure 17. JTAG test clock input timing

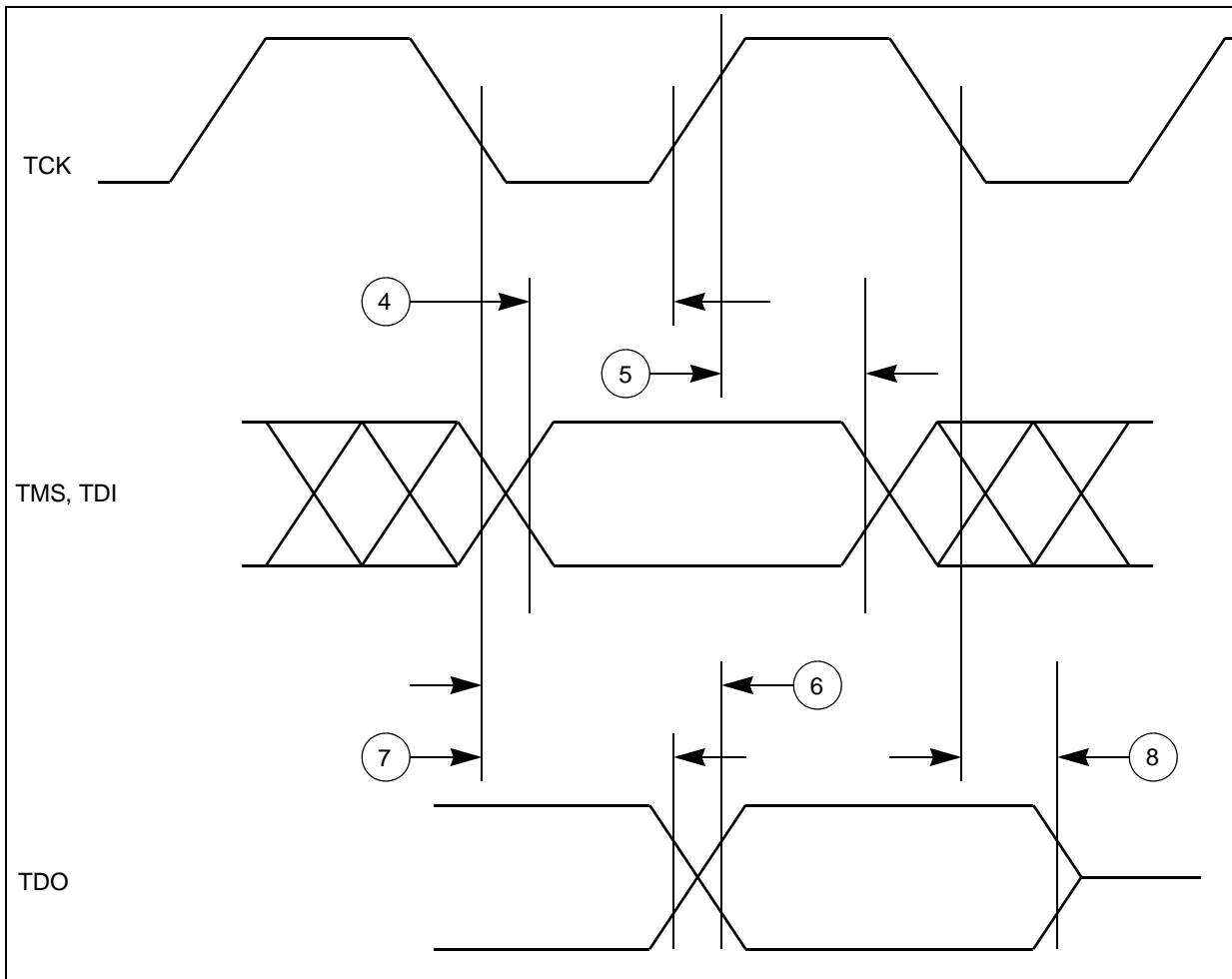

Figure 18. JTAG test access port timing

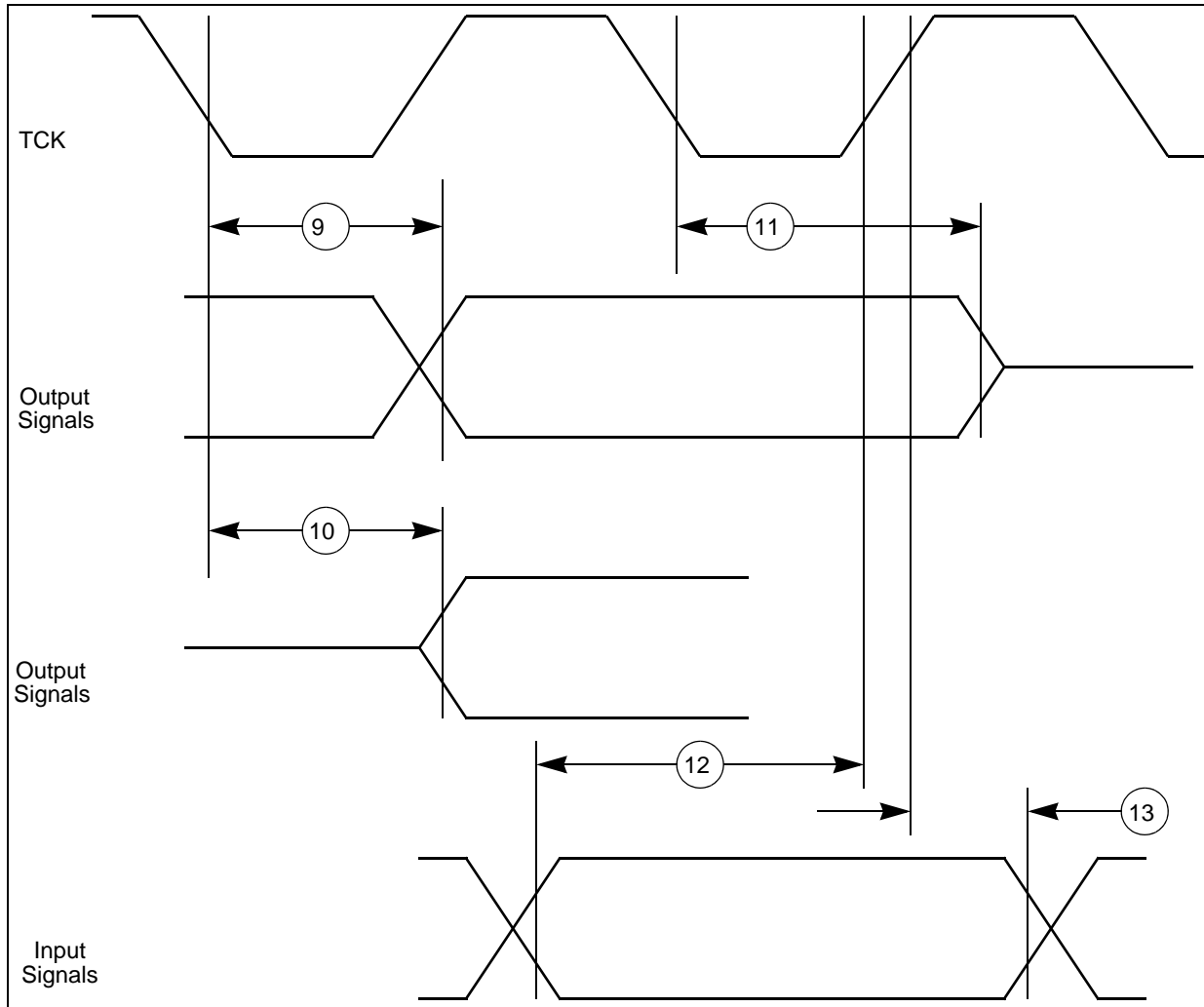

Figure 19. JTAG boundary scan timing

4.18.2 Nexus debug interface

Table 51. Nexus debug port timing¹

Num	Symbol	C	Characteristic	Min	Max	Unit	SpecID
1	t_{MCCY}	CC ²	D MCKO Cycle Time	15	—	ns	A2.1
2	t_{MDC}	CC ²	D MCKO Duty Cycle	40	60	%	A2.2
3	t_{MDOV}	CC ²	D MCKO Low to MDO Data Valid ³	0.1	0.2	t_{MCCY}	A2.3
4	t_{MSEOV}	CC ²	D MCKO Low to \overline{MSEO} Data Valid ³	0.1	0.2	t_{MCCY}	A2.4
5	$t_{EVT OV}$	CC ²	D MCKO Low to \overline{EVTO} Data Valid ³	0.1	0.2	t_{MCCY}	A2.5
6	t_{EVTIPW}	CC ²	D \overline{EVTI} Pulse Width	4	—	t_{TCYC}	A2.6
7	t_{EVTOPW}	CC ²	D \overline{EVTO} Pulse Width	1	—	t_{MCCY}	A2.7
8	t_{TCYC}	CC ²	D TCK Cycle Time ⁴	100	—	ns	A2.8
9	t_{TDC}	CC ²	D TCK Duty Cycle	40	60	%	A2.9
10	t_{NTDIS}, t_{NTMSS}	CC ²	D TDI, TMS Data Setup Time	25	—	ns	A2.10
11	t_{NTDIH}, t_{NTMSH}	CC ²	D TDI, TMS Data Hold Time	5	—	ns	A2.11
12	t_{JOV}	CC ²	D TCK Low to TDO Data Valid	0	35	ns	A2.12

¹ JTAG specifications in this table apply when used for debug functionality. All Nexus timing relative to MCKO is measured from 50% of MCKO and 50% of the respective signal. Nexus timing specified at $V_{DD} = 3.0\text{ V to }3.6\text{ V}$, $T_A = -40\text{ to }105\text{ }^\circ\text{C}$, and $CL = 50\text{ pF}$ ($CL = 30\text{ pF}$ on MCKO), with $SRC = 0b10$ for MCKO and $0b11$ for others.

² Parameter values guaranteed by design.

³ MDO, \overline{MSEO} , and \overline{EVTO} data is held valid until next MCKO low cycle.

⁴ The system clock frequency needs to be three times faster than the TCK frequency.

Nexus Dual Data Rate is not supported. The timings are mentioned for dedicated pins on 416BGA. The max value for #2, 3 and 4 above, are 0.3 of t_{MCCY} for shared nexus ports.

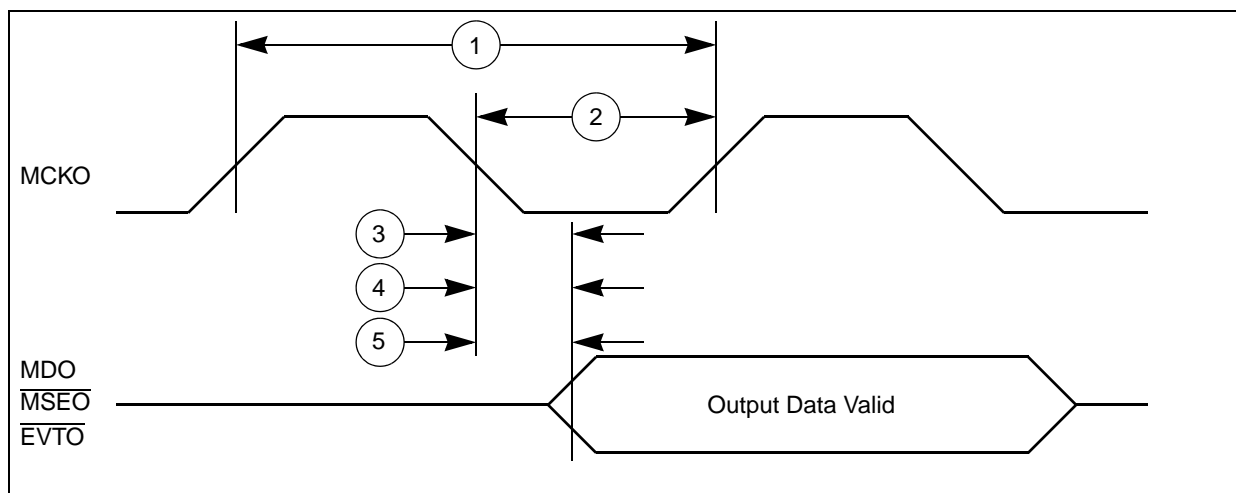

Figure 20. Nexus Output Timing

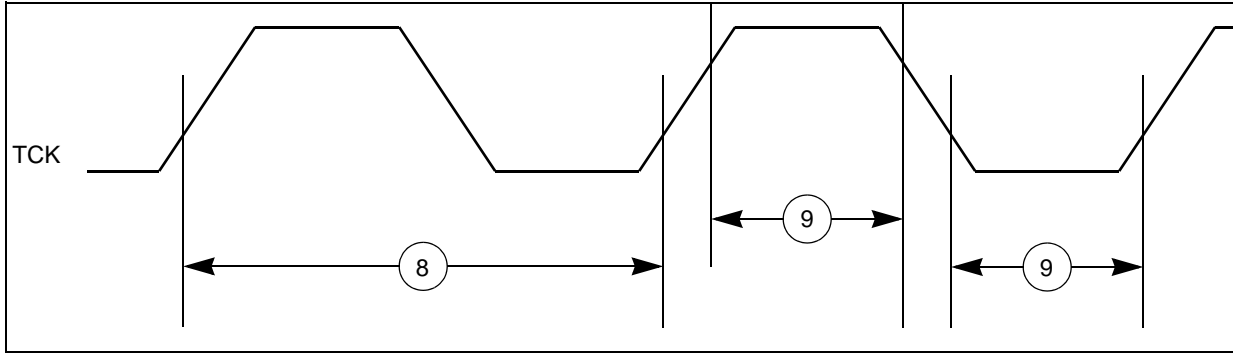

Figure 21. Nexus TCK Timing

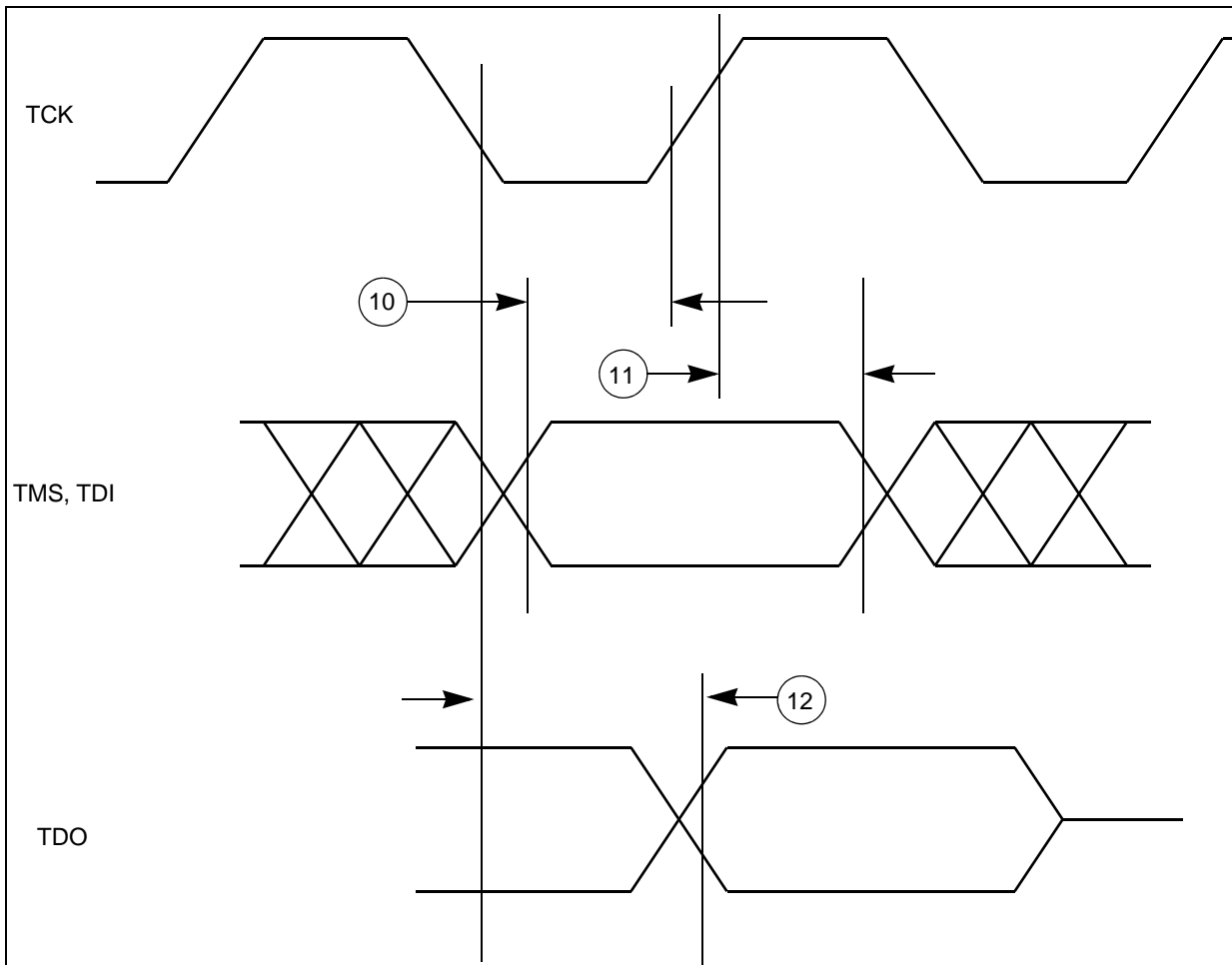

Figure 22. Nexus TDI, TMS, TDO Timing

4.18.3 Interface to TFT LCD Panels (DCU3 and DCULite)

Figure 23 depicts the LCD interface timing for a generic active matrix color TFT panel. In this figure signals are shown with positive polarity. The sequence of events for active matrix interface timing is:

- PCLK latches data into the panel on its positive edge (when positive polarity is selected). In active mode, PCLK runs continuously. This signal frequency could be from 5 to 66 MHz depending on the panel type.
- HSYNC causes the panel to start a new line. It always encompasses at least one PCLK pulse.
- VSYNC causes the panel to start a new frame. It always encompasses at least one HSYNC pulse.
- DE acts like an output enable signal to the LCD panel. This output enables the data to be shifted onto the display. When disabled, the data is invalid and the trace is off.

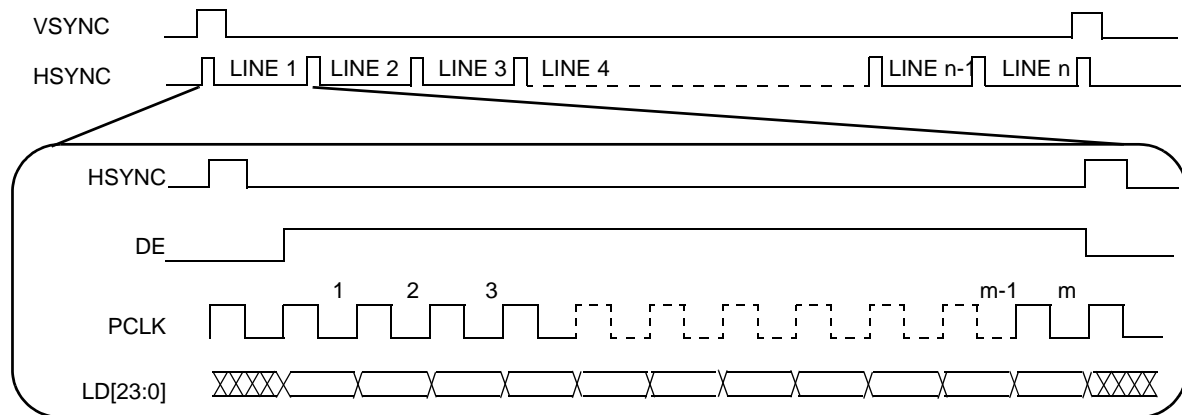

Figure 23. TFT LCD interface timing overview¹

4.18.3.1 Interface to TFT LCD Panels—Pixel Level Timings

Figure 24 depicts the horizontal timing (timing of one line), including both the horizontal sync pulse and data. All parameters shown in the diagram are programmable. This timing diagram corresponds to positive polarity of the PCLK signal (meaning the data and sync signals change on the rising edge) and active-high polarity of the HSYNC, VSYNC and DE signals. The user can select the polarity of the HSYNC and VSYNC signals via the SYN_POL register, whether active-high or active-low. The default is active-high. The DE signal is always active-high.

Pixel clock inversion and a flexible programmable pixel clock delay are also supported. They are programmed via the DCU Clock Confide Register (DCCR) in the system clock module.

The DELTA_X and DELTA_Y parameters are programmed via the DISP_SIZE register. The PW_H, BP_H and FP_H parameters are programmed via the HSYN PARA register. The PW_V, BP_V and FP_V parameters are programmed via the VSYN_PARA register.

1. In Figure 23, the “LD[23:0]” signal is “line data,” an aggregation of the DCU's RGB signals—R[0:7], G[0:7] and B[0:7].

Table 52. LCD interface timing parameters—horizontal and vertical

Num	Symbol	C	Characteristic	Value	Unit	SpecID	
1	t_{PCP}	CC ¹	D	Display pixel clock period	31.25	ns	A3.1
2	t_{PWH}	CC ¹	D	HSYNC pulse width	$PW_H * t_{PCP}$	ns	A3.2
3	t_{BPH}	CC ¹	D	HSYNC back porch width	$BP_H * t_{PCP}$	ns	A3.3
4	t_{FPH}	CC ¹	D	HSYNC front porch width	$FP_H * t_{PCP}$	ns	A3.4
5	t_{SW}	CC ¹	D	Screen width	$DELTA_X * t_{PCP}$	ns	A3.5
6	t_{HSP}	CC ¹	D	HSYNC (line) period	$(PW_H + BP_H + FP_H + DELTA_X) * t_{PCP}$	ns	A3.6
7	t_{PWV}	CC ¹	D	VSYNC pulse width	$PW_V * t_{HSP}$	ns	A3.7
8	t_{BPV}	CC ¹	D	VSYNC back porch width	$BP_V * t_{HSP}$	ns	A3.8
	t_{FPV}	CC ¹	D	VSYNC front porch width	$FP_V * t_{HSP}$	ns	A3.9
	t_{SH}	CC ¹	D	Screen height	$DELTA_Y * t_{HSP}$	ns	A3.10
	t_{VSP}	CC ¹	D	VSYNC (frame) period	$(PW_V + BP_V + FP_V + DELTA_Y) * t_{HSP}$	ns	A3.11

¹ Parameter values guaranteed by design.

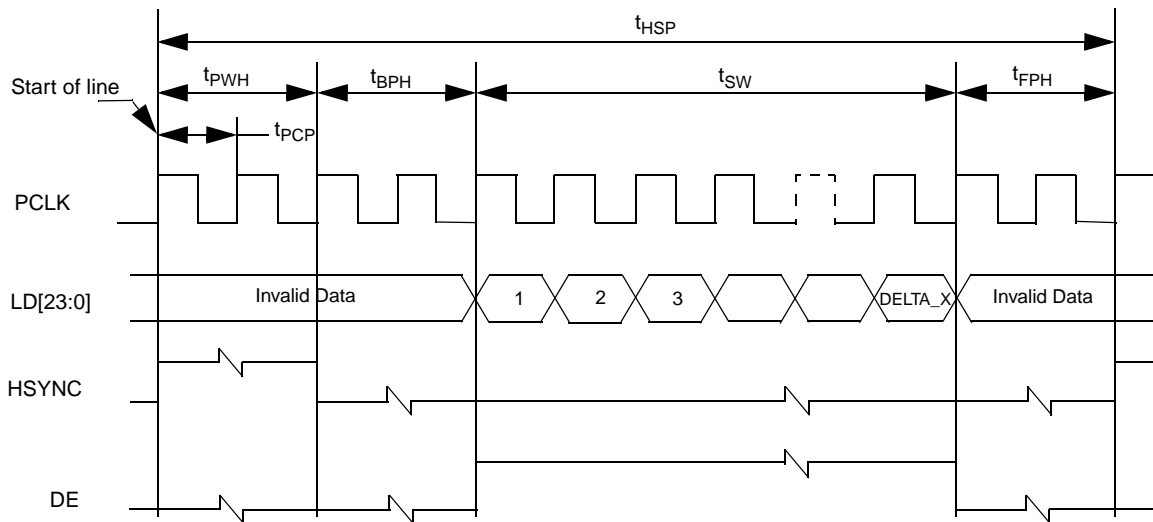

Figure 24. Horizontal sync timing

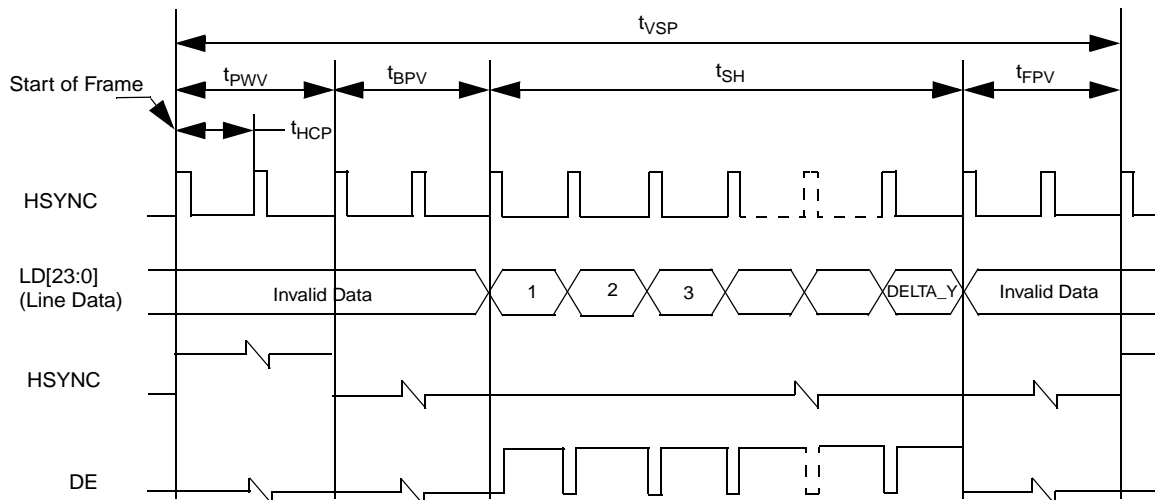

Figure 25. Vertical sync pulse

4.18.3.2 Interface to TFT LCD panels—access level

Table 53. LCD interface timing parameters^{1,2,3,4}—access level

Num	Symbol	C	Characteristic	Min. Value	Typical Value	Max. Value	Unit	SpecID
1	t_{CKP}	CC ⁵	D PDI Clock Period	31.25	—		ns	A3.12
2	t_{CHD}	CC ⁵	D Duty cycle	40	—	60	%	A3.13
3	t_{DSU}	CC ⁵	D interface data setup time	6	—		ns	A3.14
4	t_{DHD}	CC ⁵	D PDI interface data access hold time	1	—		ns	A3.15
5	t_{CSU}	CC ⁵	D PDI interface control signal setup time	3	—		ns	A3.16
6	t_{CHD}	CC ⁵	D PDI interface control signal hold time	1	—		ns	A3.17
7		CC ⁵	D TFT interface data valid after pixel clock		—	6	ns	A3.18
8		CC ⁵	D TFT interface HSYNC valid after pixel clock		—	5	ns	A3.19
9		CC ⁵	D TFT interface VSYNC valid after pixel clock		—	5.5	ns	A3.20
10		CC ⁵	D TFT interface DE valid after pixel clock		—	5.6	ns	A3.21
11		CC ⁵	D TFT interface hold time for data and control bits	2	—		ns	A3.22
12		CC ⁵	D Relative skew between the data bits		—	3.7	ns	A3.23

¹ The characteristics in this table are based on the assumption that data is output at +ve edge and displays latch data on -ve edge

² Intra bit skew is less than 2 ns

³ Load CL = 50 pf for frequency up to 20 MHz

⁴ Load CL = 25 pf for display freq from 20 to 32 MHz

⁵ Parameter values guaranteed by design.

Electrical characteristics

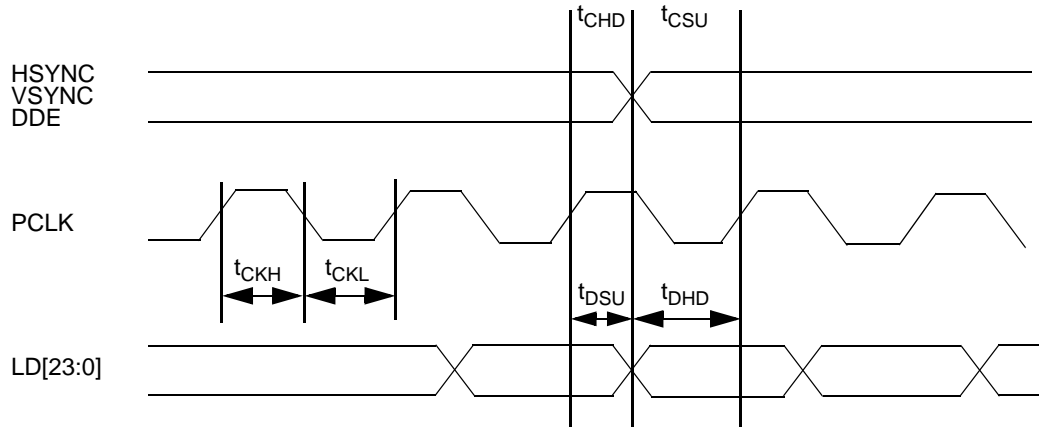

Figure 26. LCD interface timing parameters—access level

4.18.4 RSDS interface to TFT LCD panels

Table 54. RSDS electrical characteristics

Symbol	C	Parameter	Conditions ¹	Value ²			Unit	SpecID
				Min	Typ	Max		
AVDD	SR	P	Voltage on VSSE_A pin with respect to ground (V_{SS})	3.0	3.3	3.6	V	A4.1
I_{DDTX}	SR	P	Current Consumption: RSDS Transmitter - Single Cell		2.7		mA	A4.2
I_{DDPD}	SR	P	Power Down Current		10		μ A	A4.3
I_{DDBG}	SR	P	Current Consumption of Bandgap and buffer		100		μ A	A4.4
Fmax	SR	P	Data Frequency		60	85	MHz	A4.5
V_{OD}	SR	P	Differential Output Voltage	$R_L = 100$ Ohms	200	400	mV	A4.6
V_{OFF}	SR	P	Offset Voltage	$V_{CM} \pm 5\%$	0.5	1.2	V	A4.7
t_R / t_F	SR	P	Output Rise / Fall times	20% to 80%, $V_{OD}=200$ mV, $C_L = 5$ pF		500	ps	A4.8
t_{Xdelay}	SR	P	Tx Delay		3		ns	A4.9
	SR	P	Termination Resistance (external)	5% variation		100	Ohms	A4.10
	SR	P	Transmitter Settling time	After power down, high to low		10	μ s	A4.11
	SR	D	Transmitter Delay	Data in to Tx out		8	ns	A4.12

¹ $V_{DDA} = 3.3$ V \pm 10% $T_A = -40$ to $+105$ °C, unless otherwise specified.

² All values need to be confirmed during device validation.

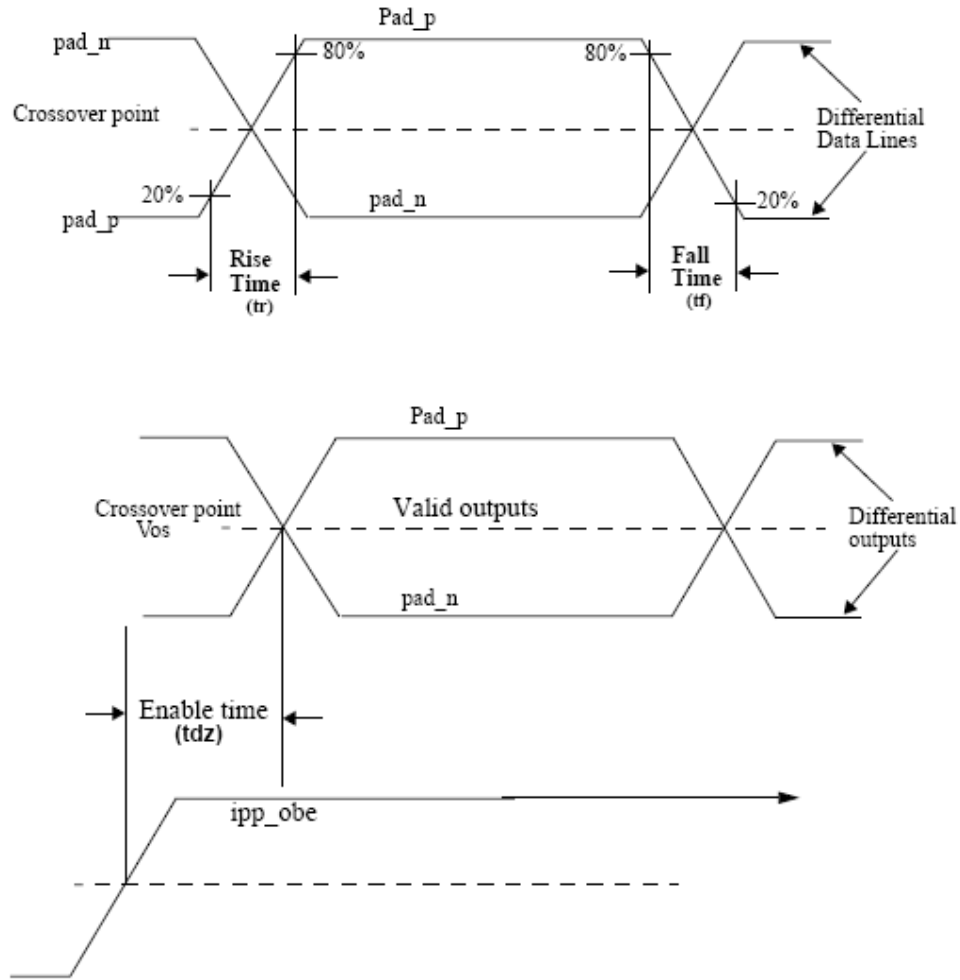

Figure 27. TCON/RSDS timing diagram

4.18.5 DRAM Interface

DDR Interface specification from ‘MCD - 32 Bit Automotive MCU - CMOS090LP2’ I/O Pad Specification Revision 1.5 - May14th 2008.

This device supports SDR, DDR1, DDR2 half and full strengths, as well as LPDDR half and full speeds. [Table 55](#) shows the SRE settings for the different modes.

Table 55. Pad mode configurations

ipp_sre[2:0]	Mode
000	1.8V LPDDR Half Speed
001	1.8V LPDDR Full Speed
010	1.8V DDR2 Half Strength
011	2.5V DDR1
100	Not supported
101	Not supported
110	1.8V DDR2 Full Strength
111	SDR

Table 56. AC Specs for SDR mode ($V_{DDE_DR} = 3.3\text{ V}$)

Parameter ^{1 2 3}	C	Values			Unit
		Min	Typ	Max	
Output Rise/Fall time	C				
Crossover voltage	C				
Input threshold	C				

¹ $V_{REF} = (V_{DDE_DR})/2$.

² C_Z at -40, 140, 25 °C.

³ Voltage (V_{DDE_DR}) variation is 3.0 V - 3.6 V.

Table 57. AC Specs for DDR2 mode ($V_{DDE_DR} = 1.8\text{ V}$)

Parameter ^{1 2 3}	C	Values			Unit
		Min	Typ	Max	
Output Rise/Fall time	C				
Crossover voltage	C				
Input threshold	C				

¹ $V_{REF} = (V_{DDE_DR})/2$.

² C_Z at -40, 140, 25 °C.

³ Voltage (V_{DDE_DR}) variation is 1.7 V - 1.9 V.

Table 58. AC Specs for DDR1 mode ($V_{DDE_DR} = 2.5\text{ V}$)

Parameter ^{1 2 3}	C	Values			Unit
		Min	Typ	Max	
Output Rise/Fall time	C				
Crossover voltage	C				
Input threshold	C				

¹ $V_{REF} = (V_{DDE_DR})/2$.

² C_Z at -40, 140, 25 °C.

³ Voltage (V_{DDE_DR}) variation is 2.3 V - 2.7 V.

Table 59. AC Specs for LPDDR mode ($V_{DDE_DR} = 1.8\text{ V}$)

Parameter ^{1 2 3}	C	Values			Unit
		Min	Typ	Max	
Output Rise/Fall time	C				
Crossover voltage	C				
Input threshold	C				

¹ $V_{REF} = (V_{DDE_DR})/2$.

² C_Z at -40, 140, 25 °C.

³ Voltage (V_{DDE_DR}) variation is 1.7 V - 1.9 V.

4.18.5.1 2.5V DDR1

Table 60. SSTL_2 Class II 2.5V DDR DC Specifications

Symbol	C	Parameter	Condition	Min	Nom	Max	Units	Notes	SpecID
vddet	P	I/O Supply Voltage		2.30	2.50]	2.70	V	JESD8-9B	A5.1
vdd	P	Core Supply Voltage		1.08	1.20	1.32	V		A5.2
Vref(dc)	P	Input Reference Voltage		1.13	1.25	1.38	V	JESD8-9B	A5.3
Vtt	P	Termination Voltage		Vref-0.04	vref	Vref+0.04	V	JESD8-9B	A5.4
$V_{ih(dc)}$	C	DC Input Logic High		Vref+0.15		vddet+0.3	V	JESD8-9B	A5.5
$V_{il(dc)}$	C	DC Input Logic Low		-0.3		Vref-0.15	V	JESD8-9B	A5.6
$V_{ih(ac)}$	C	AC Input Logic High		Vref+0.31			V	JESD8-9B	A5.7
$V_{il(ac)}$	C	AC Input Logic Low				Vref-0.31	V	JESD8-9B	A5.8
I_{in}	P	Pad input Leakage Current				+/-10	µA		A5.9

Electrical characteristics

Table 60. SSTL_2 Class II 2.5V DDR DC Specifications (continued)

Symbol	C	Parameter	Condition	Min	Nom	Max	Units	Notes	SpecID
V_{oh}	C	Output High Voltage Level		$v_{ddet}-0.35$			V		A5.10
V_{ol}	C	Output Low Voltage Level				0.35	V		A5.11
$I_{oh(dc)}$	C	Output min source dc current	$V_{out}=V_{oh}$	-16.2			mA	$v_{ddet} = 2.3V$ $V_{oh} = 1.95V$	A5.12
$I_{ol(dc)}$	C	Output min sink dc current	$V_{out}=V_{ol}$	16.2			mA	$v_{ddet} = 2.3V$ $V_{ol} = 0.35V$	A5.13

The SSTL_2 differential input switch point is at $v_{ref} = 0.50 \cdot v_{ddet}$.

Note that the JEDEC SSTL_2 specifications (JESD8-9B) for a SSTL interface for class II operation supersedes any specification in this document.

The SSTL_2 Class II output with $ipp_sre[2:0]$ set to enabling SSTL_2 2.5V DDR1 mode, at the destination, have a rise/fall time (10%-90%) between 1 ns and 2 ns over process, voltage, and temperature driving a 70 ohm transmission line with 0.167 ns t_d terminated at the destination with 70 ohms to V_{tt} ($0.5 \cdot v_{ddet}$) with 4.0 pF, representing the DDR input capacitance.

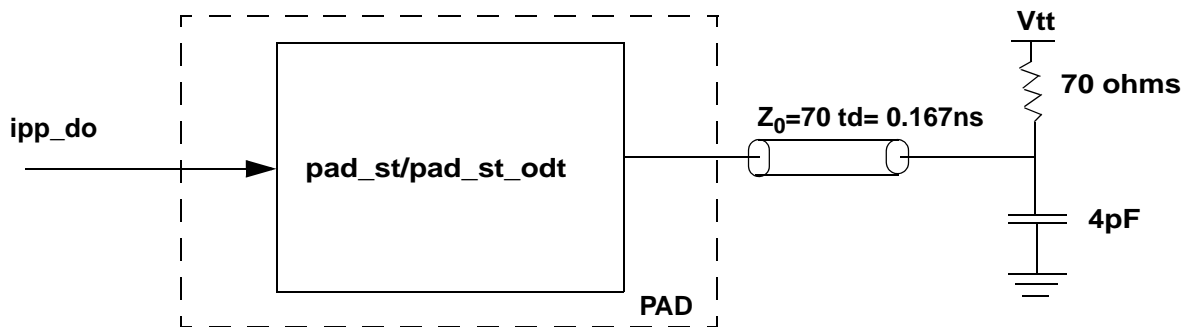

Figure 28. SSTL_2 Class II Test Load

4.18.5.2 1.8V DDR2

Table 61. SSTL_18 Class II 1.8V DDR2 DC Specifications

Symbol	C	Parameter	Condition	Min	Nom	Max	Units	Notes	SpecID
v_{ddet}	P	I/O Supply Voltage		1.7	1.8	1.9	V	JESD8-15A	A5.14
v_{dd}	P	Core Supply Voltage		1.08	1.2	1.32	V		A5.15
$V_{ref(dc)}$	P	Input Reference Voltage		0.833	0.9	1.0869	V	JESD8-15A	A5.16
V_{tt}	P	Termination Voltage		$V_{ref}-0.04$	V_{ref}	$V_{ref}+0.04$	V	JESD8-15A	A5.17
$V_{ih(dc)}$	C	DC Input Logic High		$V_{ref}+0.125$		$v_{ddet}+0.3$	V	JESD8-15A	A5.18
$V_{il(dc)}$	C	DC Input Logic Low		-0.3		$V_{ref}-0.125$	V	JESD8-15A	A5.19
$V_{ih(ac)}$	C	AC Input Logic High		$V_{ref}+0.25$			V	JESD8-15A	A5.20

Table 61. SSTL_18 Class II 1.8V DDR2 DC Specifications (continued)

Symbol	C	Parameter	Condition	Min	Nom	Max	Units	Notes	SpecID
$V_{il(ac)}$	C	AC Input Logic Low				$V_{ref}-0.25$	V	JESD8-15A	A5.21
I_{in}	P	Pad input Leakage Current				+/-10	μA		A5.22
V_{oh}	C	Output High Voltage Level		$v_{ddet}-0.28$			V		A5.23
V_{ol}	C	Output Low Voltage Level				0.28	V		A5.24
$I_{oh(dc)}$	C	Output min source dc current	$V_{out}=V_{oh}$	-13.4			mA	JESD8-15A $v_{ddet} = 1.7V$ $V_{oh} = 1.42V$	A5.25
$I_{ol(dc)}$	C	Output min sink dc current	$V_{out}=V_{ol}$	13.4			mA	JESD8-15A $v_{ddet} = 1.7V$ $V_{ol} = 0.28V$	A5.26

The SSTL_18 differential input switch point is at $v_{ref} = 0.50 * v_{ddet}$.

Note that the Jeduc SSTL_18 specifications (JESD8-15a) for a SSTL interface for class II operation supersedes any specification in this document.

The SSTL_18 Class II output with $ipp_sre[2:0]$ set to enabling $sstl_2$ 1.8V DDR2 mode, at the destination, have a rise/fall time (10% -90%) between 0.4 ns and 1.0 ns over process, voltage, and temperature driving a 70 ohm transmission line with 0.167 ns t_d terminated at the destination with 70 ohms to V_{tt} ($0.5 * v_{ddet}$) with 4.0 pf, representing the DDR2 input capacitance. See (Figure 29. "SSTL_18 CLass II Test Load").

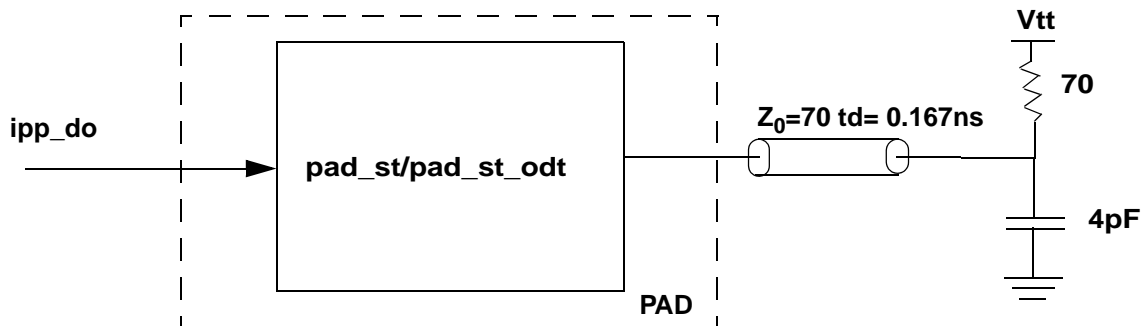

Figure 29. SSTL_18 CLass II Test Load

4.18.5.3 1.8V LPDDR

Table 62. 1.8V LPDDR DC Specifications

Symbol	C	Parameter	Condition	Min	Nom	Max	Units	Notes	SpecID
vddet	P	I/O Supply Voltage		1.7	1.8	1.9	V	JESD79-4	A5.27
vdd	P	Core Supply Voltage		1.08	1.2	1.32	V		A5.28
Data Inputs (DQ, DM, DQS)									A5.29
V _{ih(dc)}	C	DC Input Logic High		vddet*0.7		vddet+0.3	V	JESD79-4	A5.30
V _{il(dc)}	C	DC Input Logic Low		-0.3		vddet*0.3	V	JESD79-4	A5.31
V _{ih(ac)}	C	AC Input Logic High		vddet*0.8		vddet+0.3	V	JESD79-4	A5.32
V _{il(ac)}	C	AC Input Logic low		-0.3		vddet*0.2	V	JESD79-4	A5.33
Data Outputs (DQ, DQS)									A5.34
V _{oh}	C	Output High Voltage Level	I _{oh} =-0.1mA	vddet*0.9			V	JESD79-4	A5.35
V _{ol}	C	Output Low Voltage Level	I _{ol} =0.1mA			vddet*0.1	V	JESD79-4	A5.36

Note that the final JEDEC LPDDR SDRAM specifications (JESD79-4) for LPDDR operation supersedes any specification in this document.

The SSTL_18 output with ipp_sre[2:0] set to enabling 1.8V LPDDR mode, at the destination, have a rise/fall time (10%-90%) between 0.4 ns and 1.0 ns over process, voltage, and temperature driving a 70 ohm transmission line with 0.167 ns td terminated at the destination with 70 ohms to V_{tt} (0.5*vddet) with 4.0 pf, representing the DDR input capacitance. See Figure 27.

4.18.6 Video Input Unit timing

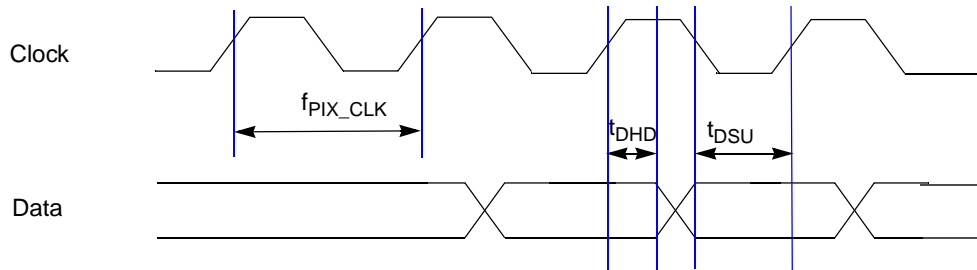

Figure 30. VIU2 timing diagram

Table 63. VIU2 timing parameters

Parameter	C	Description	Min	Typ	Max	Unit	SpecID
f _{PIX_CLK}	D	VIU2 pixel clock frequency	—	—	64	MHz	A6.1
t _{DSU}	D	VIU2 data setup time	4	—	—	ns	A6.2
t _{DHD}	D	VIU2 data hold time	1	—	—	ns	A6.3

4.18.7 External Interrupt (IRQ) and Non-Maskable Interrupt (NMI) Timing

Table 64. IRQ and NMI Timing

Num	Symbol	C	Characteristic	Min. Value	Max. Value	Unit	SpecID
1	t_{IPWL}	CC ¹	D IRQ/NMI Pulse Width Low	200	—	ns	A7.1
2	t_{IPWH}	CC ¹	D IRQ/NMI Pulse Width High	200	—	ns	A7.2
3	t_{ICYC}	CC ¹	D IRQ/NMI Edge to Edge Time ²	400	—	ns	A7.3

¹ Parameter values guaranteed by design.

² Applies when IRQ/NMI pins are configured for rising edge or falling edge events, but not both.

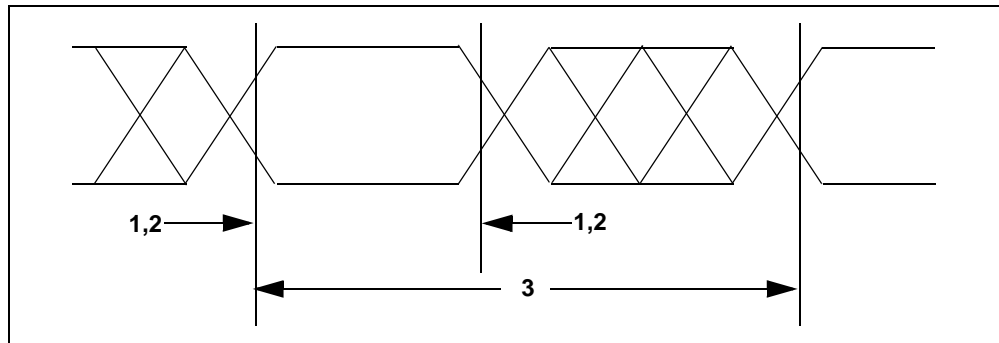

Figure 31. IRQ and NMI Timing

4.18.8 eMIOS timing

Table 65. eMIOS timing¹

Num	Symbol	C	Characteristic	Min. value ²	Max. value	Unit	SpecID
1	t_{MIPW}	CC ³	D eMIOS Input Pulse Width	4	—	t_{CYC}	A8.1
2	t_{MOPW}	CC ³	D eMIOS Output Pulse Width	1	—	t_{CYC}	A8.2

¹ eMIOS timing specified at $f_{SYS} = 64$ MHz, $V_{DD12} = 1.14$ V to 1.32 V, $V_{DDE_x} = 3.0$ V to 5.5 V, $T_A = -40$ to 105 °C, and $CL = 50$ pF with SRC = 0b00

² There is no limitation on the peripheral for setting the minimum pulse width, the actual width is restricted by the pad delays. Refer to the pad specification section for the details.

³ Parameter values guaranteed by design.

4.18.9 FlexCAN timing

The CAN functions are available as TX pins at normal IO pads and as RX pins at the always on domain. There is no filter for the wakeup dominant pulse. Any high-to-low edge can cause wakeup if configured.

Table 66. FlexCAN timing¹

Num	Symbol	C	Characteristic	Min. value	Max. value	Unit	SpecID
1	t_{CANOV}	CC ²	D CTNX Output Valid after CLKOUT Rising Edge (Output Delay)	—	22.48	ns	A10.1
2	t_{CANSU}	CC ²	D CNRX Input Valid to CLKOUT Rising Edge (Setup Time)	—	12.46	ns	A10.2

¹ FlexCAN timing specified at $f_{SYS} = 64$ MHz, $V_{DD12} = 1.14$ V to 1.32 V, $V_{DDE_x} = 3.0$ V to 5.5 V, $T_A = -40$ to 105 °C, and $CL = 50$ pF with $SRC = 0b00$.

² Parameter values guaranteed by design.

4.18.10 Deserial Serial Peripheral Interface (DSPI)

Table 67. DSPI Timing¹

Num	Symbol	C	Characteristic	Min	Max	Unit	SpecID
1	t_{SCK}	CC ²	D SCK Cycle Time ^{3,4}	60 ⁵	—	ns	A11.1
2	t_{CSC}	CC ²	D PCS to SCK Delay ⁶	-	—	ns	A11.2
3	t_{ASC}	CC ²	D After SCK Delay ⁷	20	—	ns	A11.3
4	t_{SDC}	CC ²	D SCK Duty Cycle	$t_{SCK}/2 - 2ns$	$t_{SCK}/2 + 2ns$	ns	A11.4
5	t_A	CC ²	D Slave Access Time (PCSx active to SOUT driven)	—	25	ns	A11.5
6	t_{DIS}	CC ²	D Slave SOUT Disable Time (PCSx inactive to SOUT High-Z or invalid)	—	25	ns	A11.6

Table 67. DSPI Timing¹ (continued)

Num	Symbol	C	Characteristic	Min	Max	Unit	SpecID	
7	t _{SUI}	CC ²	D Data Setup Time for Inputs	Master (MTFE = 0)	20	—	ns	A11.7
				Slave	10	—	ns	
				Master (MTFE = 1, CPHA = 0) ⁸	5	—	ns	
				Master (MTFE = 1, CPHA = 1)	35	—	ns	
8	t _{HI}	CC ²	D Data Hold Time for Inputs	Master (MTFE = 0)	-4	—	ns	A11.8
				Slave	10	—	ns	
				Master (MTFE = 1, CPHA = 0) ⁸	26	—	ns	
				Master (MTFE = 1, CPHA = 1)	-4	—	ns	
9	t _{SUO}	CC ²	D Data Valid (after SCK edge)	Master (MTFE = 0)	—	15	ns	A11.9
				Slave	—	20	ns	
				Master (MTFE = 1, CPHA=0)	—	30	ns	
				Master (MTFE = 1, CPHA=1)	—	15	ns	
10	t _{HO}	CC ²	D Data Hold Time for Outputs	Master (MTFE = 0)	-15	—	ns	A11.10
				Slave	5.5	—	ns	
				Master (MTFE = 1, CPHA = 0)	0	—	ns	
				Master (MTFE = 1, CPHA = 1)	-15	—	ns	

¹ DSPI timing specified at VDDE_x = 3.0 V to 3.6 V, T_A = -40 to 105 °C, and CL = 50 pF with SRC = 0b10.

² Parameter values guaranteed by design.

³ The minimum SCK Cycle Time restricts the baud rate selection for given system clock rate.

⁴ The actual minimum SCK Cycle Time is limited by pad performance.

⁵ Maximum clock possible is System clock/2.

⁶ The maximum value is programmable in DSPI_CTARx[PSSCK] and DSPI_CTARx[CSSCK], program PSSCK=2 & CSSCK = 2

⁷ The maximum value is programmable in DSPI_CTARx[PASC] and DSPI_CTARx[ASC]

⁸ This delay value is corresponding to SMPL_PT=00b which is bit field 9 and 8 of DSPI_MCR register.

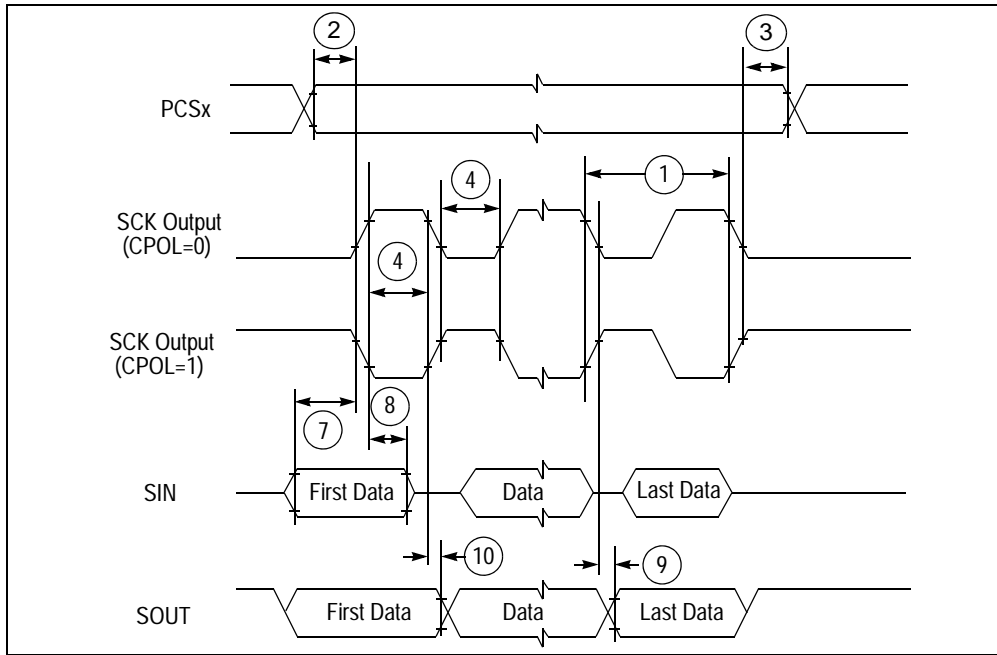

Figure 32. DSPI classic SPI timing—master, CPHA = 0

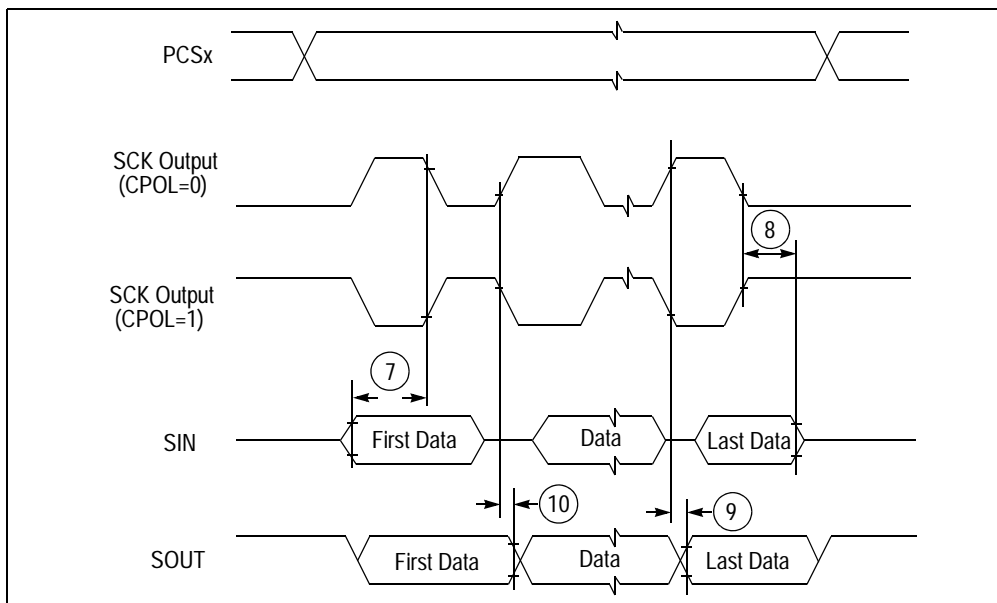

Figure 33. DSPI classic SPI timing—master, CPHA = 1

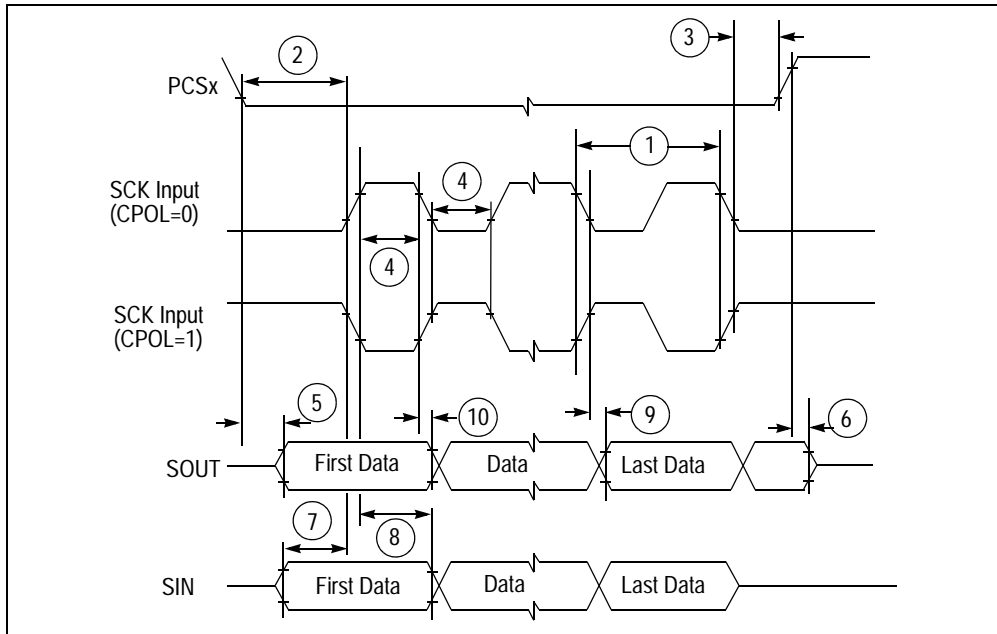

Figure 34. DSPI classic SPI timing—slave, CPHA = 0

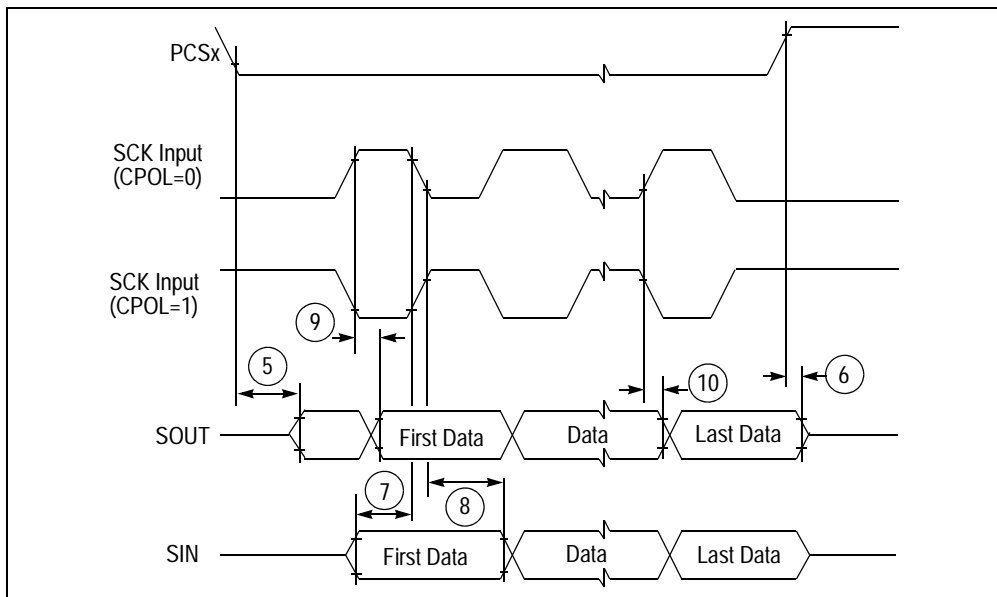

Figure 35. DSPI classic SPI timing—slave, CPHA = 1

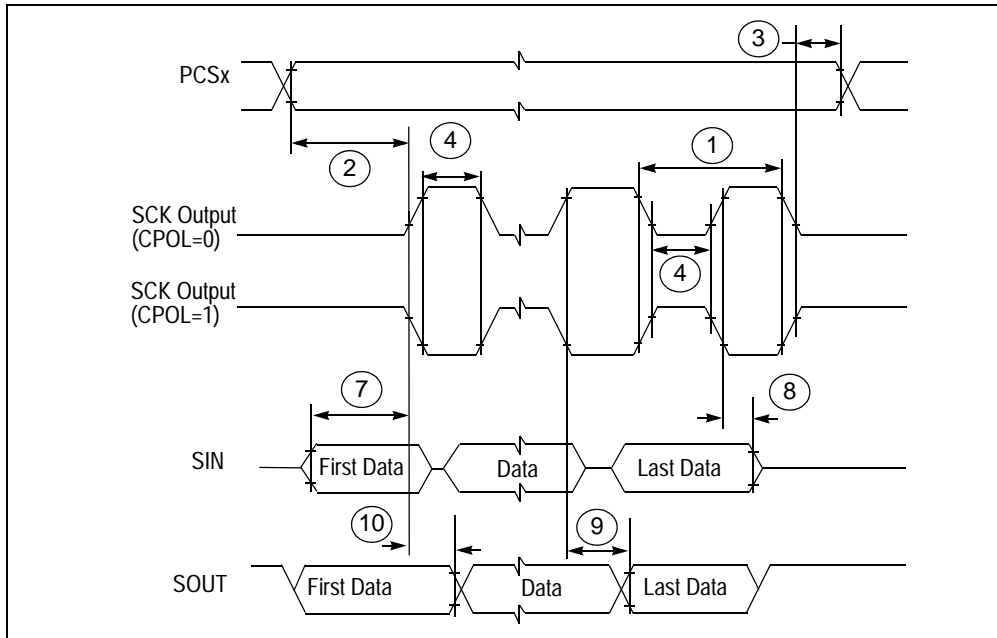

Figure 36. DSPI modified transfer format timing—master, CPHA = 0

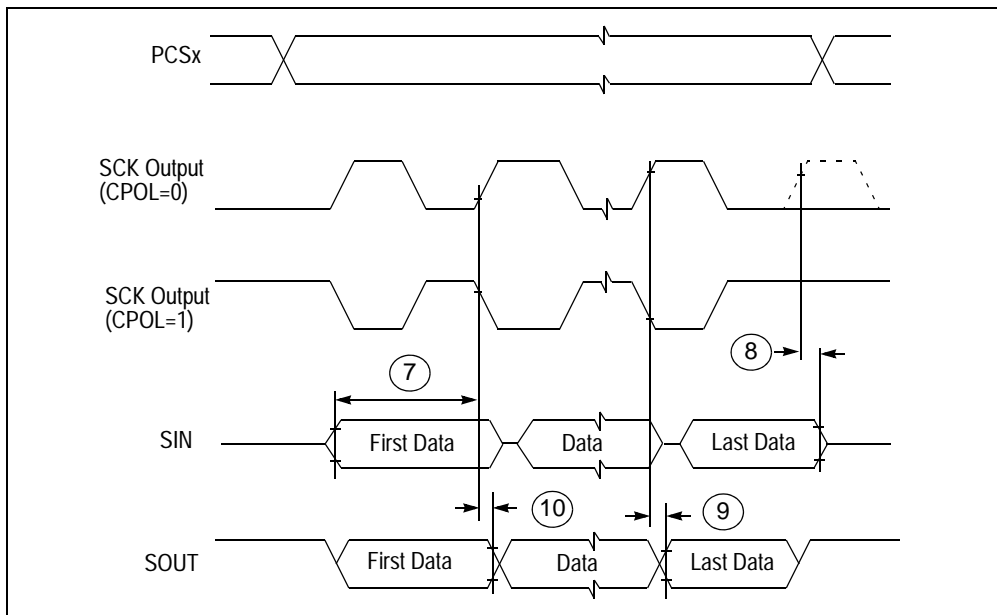

Figure 37. DSPI modified transfer format timing—master, CPHA = 1

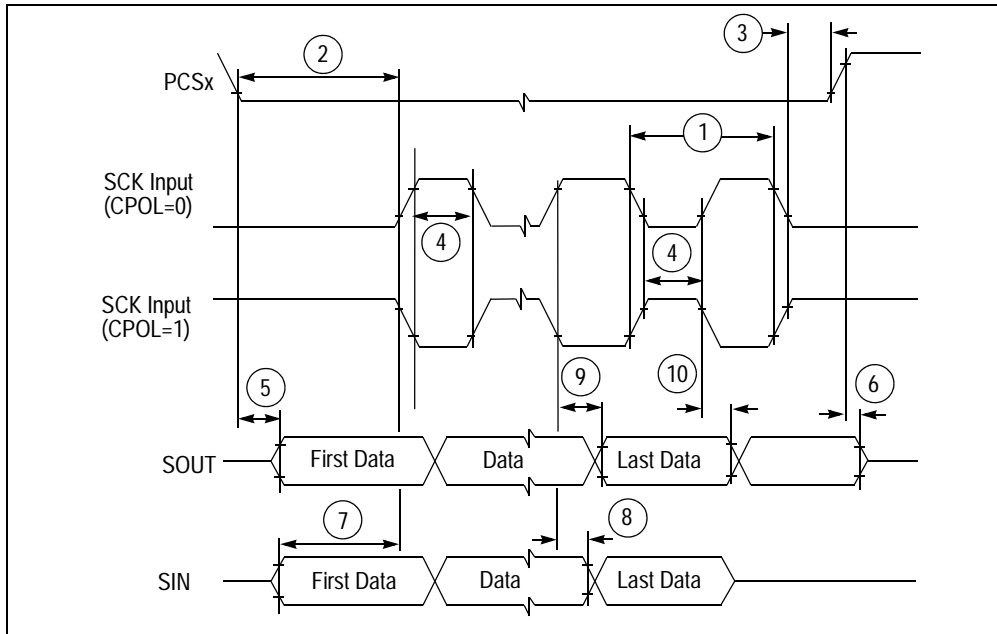

Figure 38. DSPI modified transfer format timing—slave, CPHA = 0

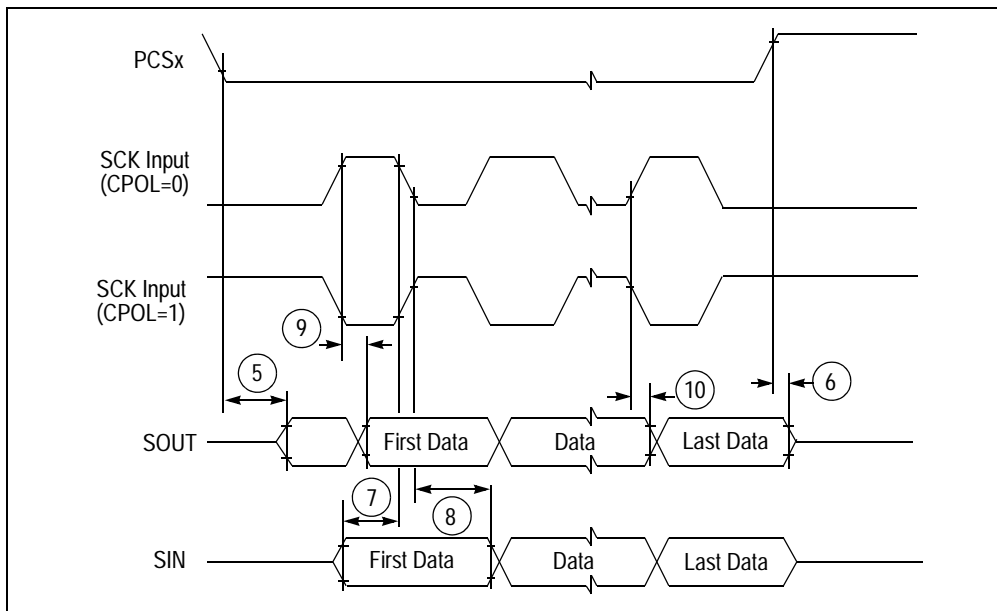

Figure 39. DSPI modified transfer format timing—slave, CPHA = 1

4.18.11 I²C timingTable 68. I²C input timing specifications—SCL and SDA

Num	Symbol	C	Characteristic	Min. Value	Max. Value	Unit	SpecID
1	—	CC ¹	D Start condition hold time	2	—	IP-Bus Cycle ²	A12.1
2	—	CC ¹	D Clock low time	8	—	IP-Bus Cycle ²	A12.2
4	—	CC ¹	D Data hold time	0.0	—	ns	A12.3
6	—	CC ¹	D Clock high time	4	—	IP-Bus Cycle ²	A12.4
7	—	CC ¹	D Data setup time	0.0	—	ns	A12.5
8	—	CC ¹	D Start condition setup time (for repeated start condition only)	2	—	IP-Bus Cycle ²	A12.6
9	—	CC ¹	D Stop condition setup time	2	—	IP-Bus Cycle ²	A12.7

¹ Parameter values guaranteed by design.

² Inter Peripheral Clock is the clock at which the I²C peripheral is working in the device

Table 69. I²C output timing specifications—SCL and SDA

Num	Symbol	C	Characteristic	Min. Value	Max. Value	Unit	SpecID
1 ¹	—	CC ²	D Start condition hold time	6	—	IP-Bus Cycle ³	A12.8
2 ¹	—	CC ²	D Clock low time	10	—	IP-Bus Cycle ²	A12.9
3 ⁴	—	CC ²	D SCL/SDA rise time	—	99.6	ns	A12.10
4 ¹	—	CC ²	D Data hold time	7	—	IP-Bus Cycle ²	A12.11
5 ¹	—	CC ²	D SCL/SDA fall time	—	99.5	ns	A12.12
6 ¹	—	CC ²	D Clock high time	10	—	IP-Bus Cycle ²	A12.13
7 ¹	—	CC ²	D Data setup time	2	—	IP-Bus Cycle ²	A12.14
8 ¹	—	CC ²	D Start condition setup time (for repeated start condition only)	20	—	IP-Bus Cycle ²	A12.15
9 ¹	—	CC ²	D Stop condition setup time	10	—	IP-Bus Cycle ²	A12.16

¹ Programming IBFD (I²C bus Frequency Divider) with the maximum frequency results in the minimum output timings listed. The I²C interface is designed to scale the data transition time, moving it to the middle of the SCL low period. The actual position is affected by the prescale and division values programmed in IFDR.

² Parameter values guaranteed by design.

³ Inter Peripheral Clock is the clock at which the I²C peripheral is working in the device

⁴ Because SCL and SDA are open-drain-type outputs, which the processor can only actively drive low, the time SCL or SDA takes to reach a high level depends on external signal capacitance and pull-up resistor values.

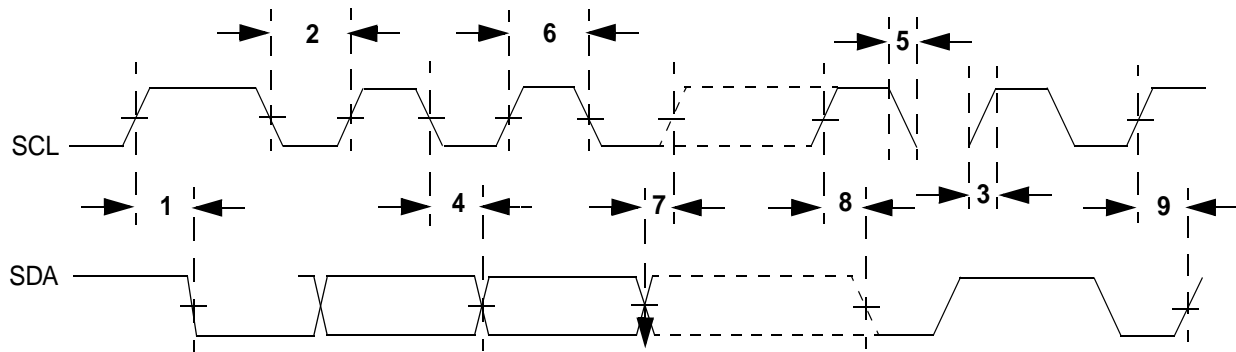
Figure 40. I²C input/output timing

4.18.12 QuadSPI timing

The following notes apply to [Table 70](#) and [Table 71](#):

- All data is based on a negative edge data launch from MPC5645S and a positive edge data capture, as shown in the timing diagrams in this section.
- The supply conditions, over a temperature range of -45 °C to 125 °C/150 °C, are as follows:
 - IO voltage: 3.0 V, Core supply: 1.2 V
 - IO voltage: 3.3 V, Core supply: 1.2 V
 - IO voltage: 3.6 V, Core supply: 1.2 V
- The actual frequency at which the device can work will be a combination of this data and the clock pad profile.
- All measurements are considering 70% of VDDE levels for clock pin and 50% of VDDE level for data pins.
- Timings assume a setting of 0x0000_000x for QSPI_SMPR register (see the reference manual for details).
- A negative value of hold is an indication of pad delay on the clock pad (delay b/w actual edge capturing data in the device vs. edge appearing at the pin).
- Measurements are with a load of 50 pF on output pins
- The clock profile is measured at 30% to 70% levels of VDDE.

Table 70. QuadSPI timing specifications, maximum temperature 125 °C

Symbol	C	Parameter	Value			Unit	SpecID
			Min	Typ	Max		
Tcq	CC	T	Clock to Q delay			ns	A13.1
Ts	CC	T	Setup time for incoming data			ns	A13.2
Th	CC	T	Hold time requirement for incoming data			ns	A13.3
tr	CC	T	Clock pad rise time			ns	A13.4
tf	CC	T	Clock pad fall time			ns	A13.5

The numbers in [Figure 41](#) and [Figure 42](#) correspond to events as described in [Table 71](#).

Table 71. QuadSPI timing events

Number	Event
1	Last address out
2	Address captured at flash memory
3	Data out from flash memory
4	Ideal data capture edge
5	Delayed data capture edge with QSPI_SMPR=0x0000_000X
6	Delayed data capture edge with QSPI_SMPR=0x0000_002X
7	Delayed data capture edge with QSPI_SMPR=0x0000_004X
8	Delayed data capture edge with QSPI_SMPR=0x0000_006X

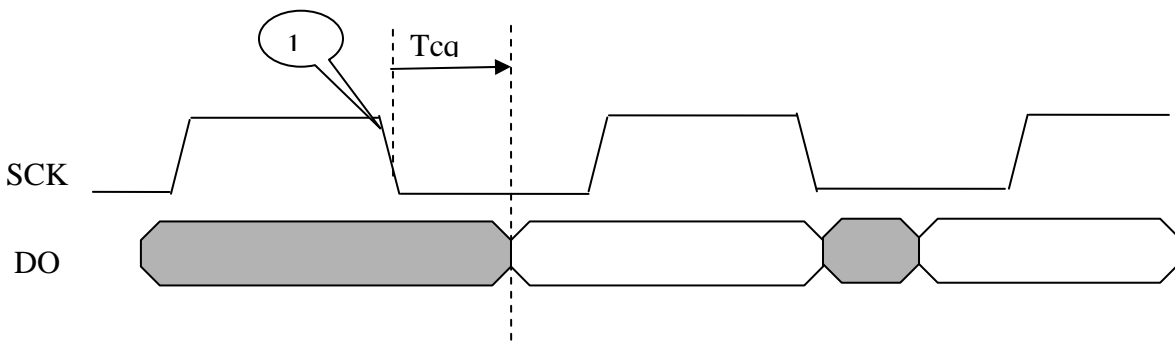
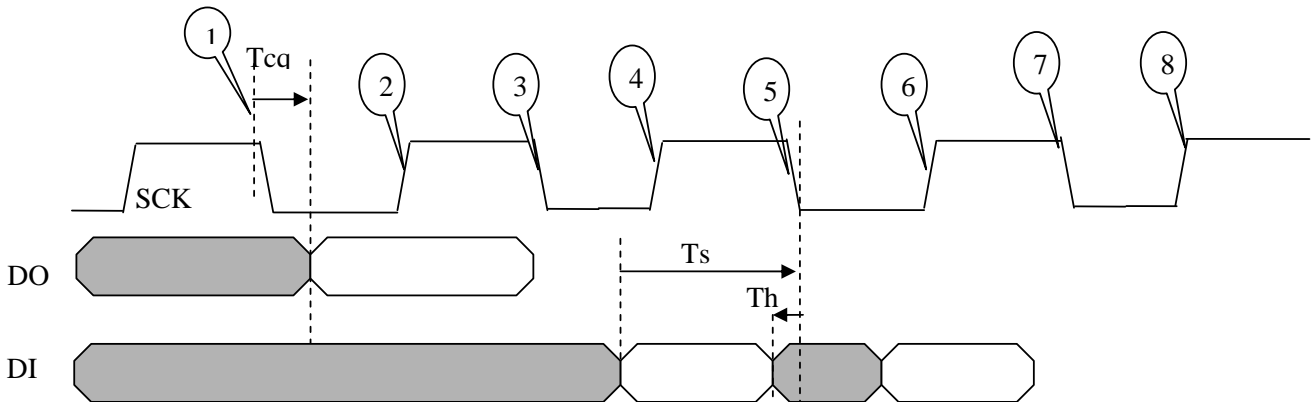
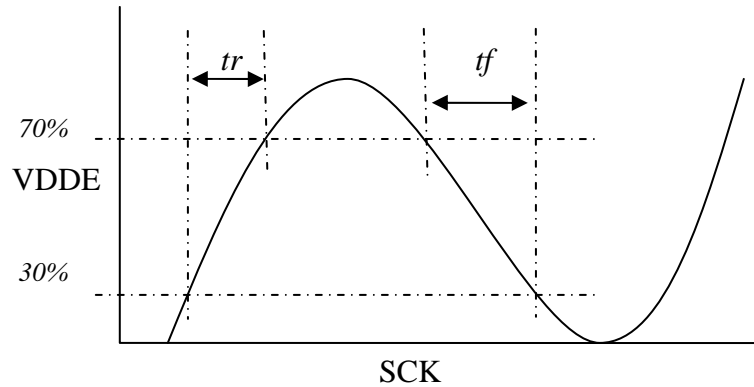

Figure 41. QuadSPI output timing



Note: Ts and Th correspond to QSPI_SMPR = 0x0000_000X.

Figure 42. QuadSPI input timing



Note: t_r and t_f measured at 30% and 70% of VDDE

Figure 43. QuadSPI clock profile

4.18.13 TCON/RSDS timing

The following notes apply to Table 72:

- Measurement condition: $v_{dde}/v_{dd33} = 3.3\text{ V} \pm 10\%$, $v_{dd} = 1.2\text{ V} \pm 10\%$, $v_{ss}/v_{sse} = 0\text{ V}$, $T = -40\text{--}150\text{ }^\circ\text{C}$
- Termination: $100\ \Omega \pm 5\%$
- VREFH_RSDS terminations of $47\ \mu\text{F}$

Table 72. TCON/RSDS timing

Symbol	C	Parameter	Condition	Value			Unit	SpecID	
				Min	Typ	Max			
V_{OD}	CC	C	Differential output voltage	RSDS mode	391	-	471	mV	A14.1
V_{OS}	CC	C	Common mode voltage	100 Ω termination between Pad_p and Pad_n	1.17	-	1.4	V	A14.2
t_r	CC	C	Rise time	Transition from 20% to 80%	606	-	844	ps	A14.3
t_f	CC	C	Fall time	Transition from 20% to 80%	607	-	842	ps	A14.4
t_{plh}	CC	D	Propagation delay, low to high	—	-	2.65	-	ns	A14.5
t_{phl}	CC	D	Propagation delay, high to low	—	-	2.47	-	ns	A14.6
t_{dz}	CC	D	Start-up time	—	-	200	-	μs	A14.7
$t_{skew}^{1\ 2\ 3}$	CC	C	Skew between different RSDS lines	Max and min skew between clock and data pads	-	-	-	ps	A14.8

¹ There are eight programmable bits to provide 256 different skew numbers with various combinations of these bits.

² Default value of all the eight skew options are all "1".

³ All "0" combination of eight bits is not valid.

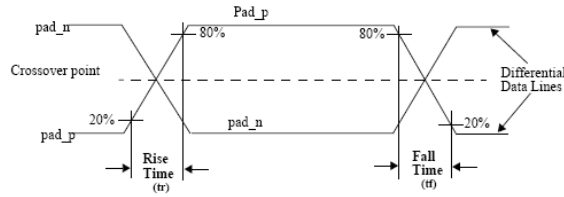

Figure 44. Rise/fall transition, part 1

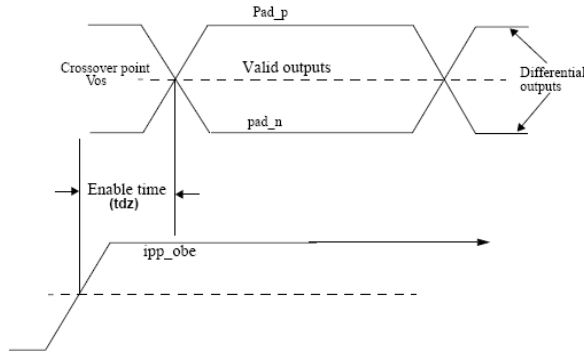

Figure 45. Rise/fall transition, part 2

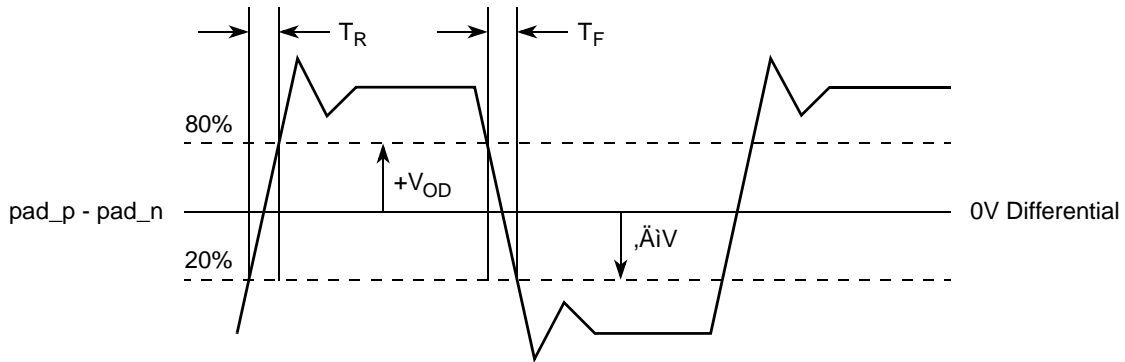
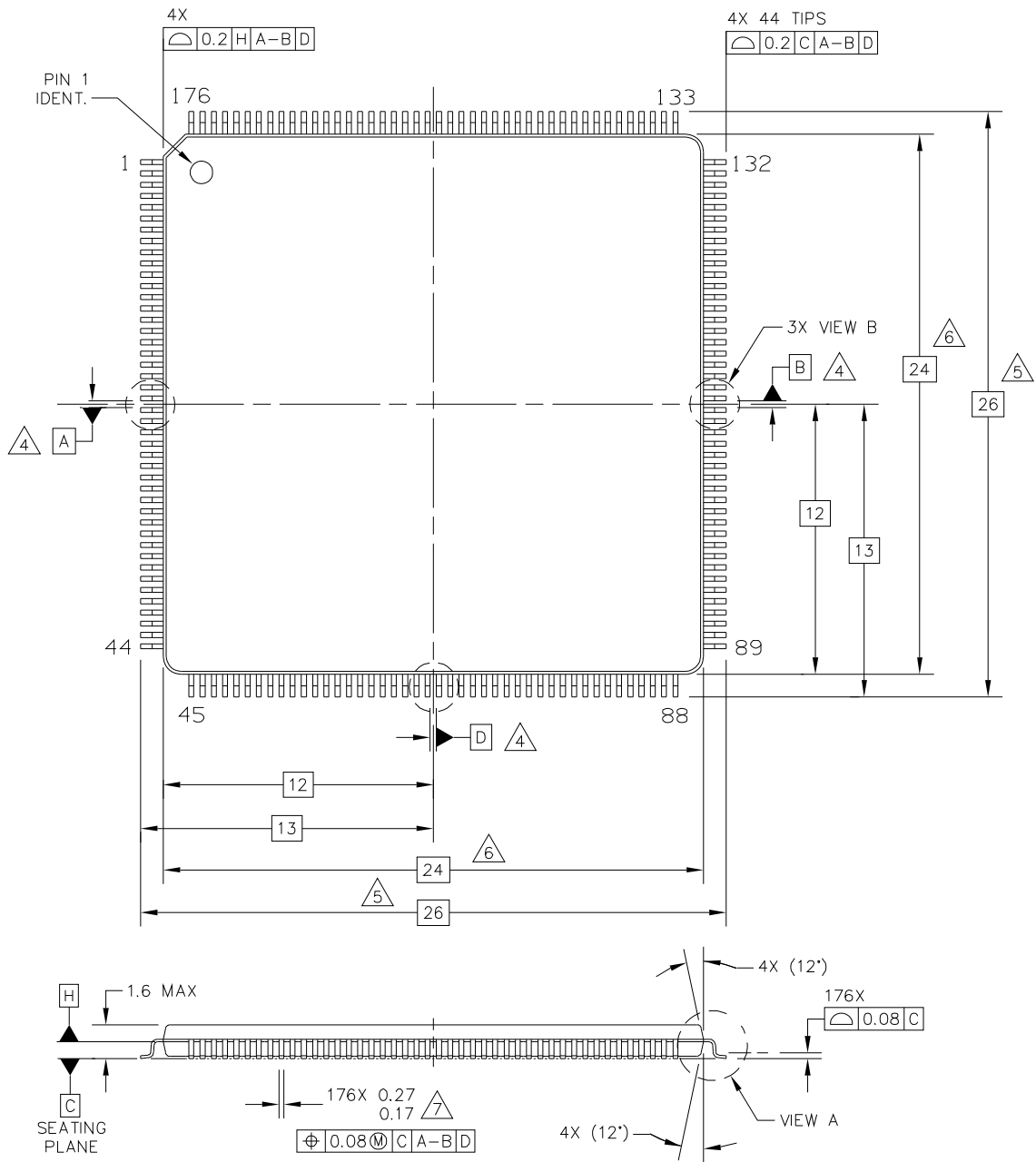

Figure 46. Illustration of t_r , t_f , and V_{OD}

5 Package mechanical data

5.1 176 LQFP



© FREESCALE SEMICONDUCTOR, INC. ALL RIGHTS RESERVED.	MECHANICAL OUTLINE	PRINT VERSION NOT TO SCALE	
TITLE: 176 LD LQFP, 24 X 24 PKG, 0.5 PITCH, 1.4 THICK		DOCUMENT NO: 98ASS23479W	REV: C
		CASE NUMBER: 1101-02	29 SEP 2009
		STANDARD: JEDEC MS-026 BGA	

Figure 47. LQFP176 mechanical drawing (part 1 of 3)

Package mechanical data

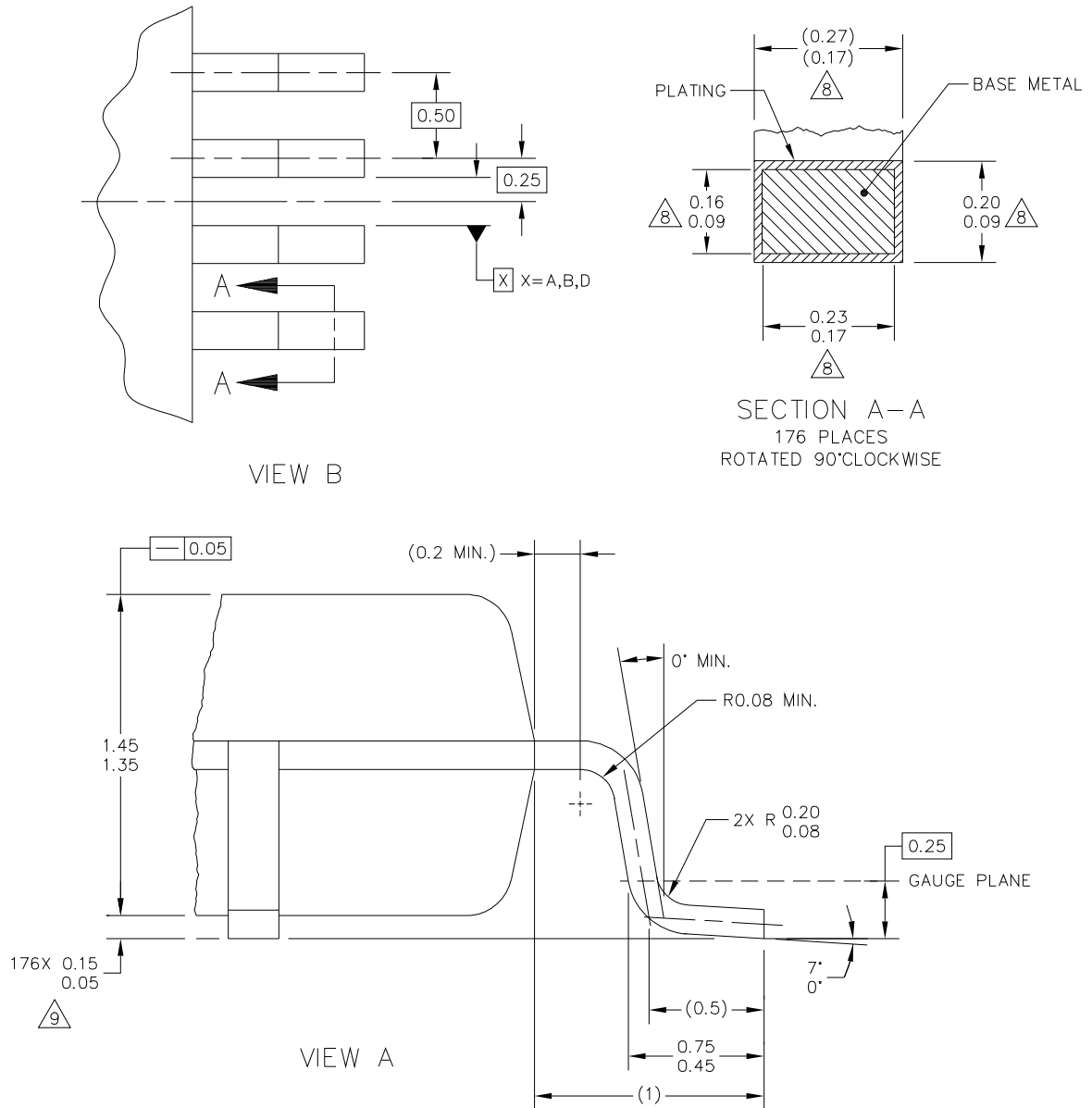

© FREESCALE SEMICONDUCTOR, INC. ALL RIGHTS RESERVED.	MECHANICAL OUTLINE	PRINT VERSION NOT TO SCALE	
TITLE: 176 LD LQFP, 24 X 24 PKG, 0.5 PITCH, 1.4 THICK	DOCUMENT NO: 98ASS23479W		REV: C
	CASE NUMBER: 1101-02		29 SEP 2009
	STANDARD: JEDEC MS-026 BGA		

Figure 48. LQFP176 mechanical drawing (part 2 of 3)

NOTES:

1. DIMENSIONS AND TOLERANCING PER ASME Y14.5M-1994.
2. DIMENSIONS IN MILLIMETERS.
3. DATUM PLANE H IS LOCATED AT BOTTOM OF LEAD AND IS COINCIDENT WITH THE LEAD WHERE THE LEAD EXITS THE PLASTIC BODY AT THE BOTTOM OF THE PARTING LINE.
4. DATUMS A, B AND D TO BE DETERMINED AT DATUM PLANE H.
5. THIS DIMENSIONS TO BE DETERMINED AT SEATING PLANE, DATUM C.
6. THIS DIMENSIONS DO NOT INCLUDE MOLD PROTRUSION. ALLOWABLE PROTRUSION IS 0.25 PER SIDE. THIS DIMENSIONS INCLUDE MOLD MISMATCH AND ARE DETERMINED AT DATUM PLANE H.
7. THIS DIMENSION DOES NOT INCLUDE DAMBAR PROTRUSION. DAMBAR PROTRUSION SHALL NOT CAUSE THE LEAD WIDTH TO EXCEED 0.35. MINIMUM SPACE BETWEEN PROTRUSION AND ADJACENT LEAD 0.07.
8. THESE DIMENSIONS APPLY TO THE FLAT SECTION OF THE LEAD BETWEEN 0.1 MM AND 0.25 MM FROM THE LEAD TIP.
9. DISTANCE FROM THE SEATING PLANE TO THE LOWEST POINT ON THE PACKAGE BODY.

© FREESCALE SEMICONDUCTOR, INC. ALL RIGHTS RESERVED.	MECHANICAL OUTLINE	PRINT VERSION NOT TO SCALE	
TITLE: 176 LD LQFP, 24 X 24 PKG, 0.5 PITCH, 1.4 THICK	DOCUMENT NO: 98ASS23479W	REV: C	
	CASE NUMBER: 1101-02	29 SEP 2009	
	STANDARD: JEDEC MS-026 BGA		

Figure 49. LQFP176 mechanical drawing (part 3 of 3)

5.2 208 LQFP

Package mechanical data

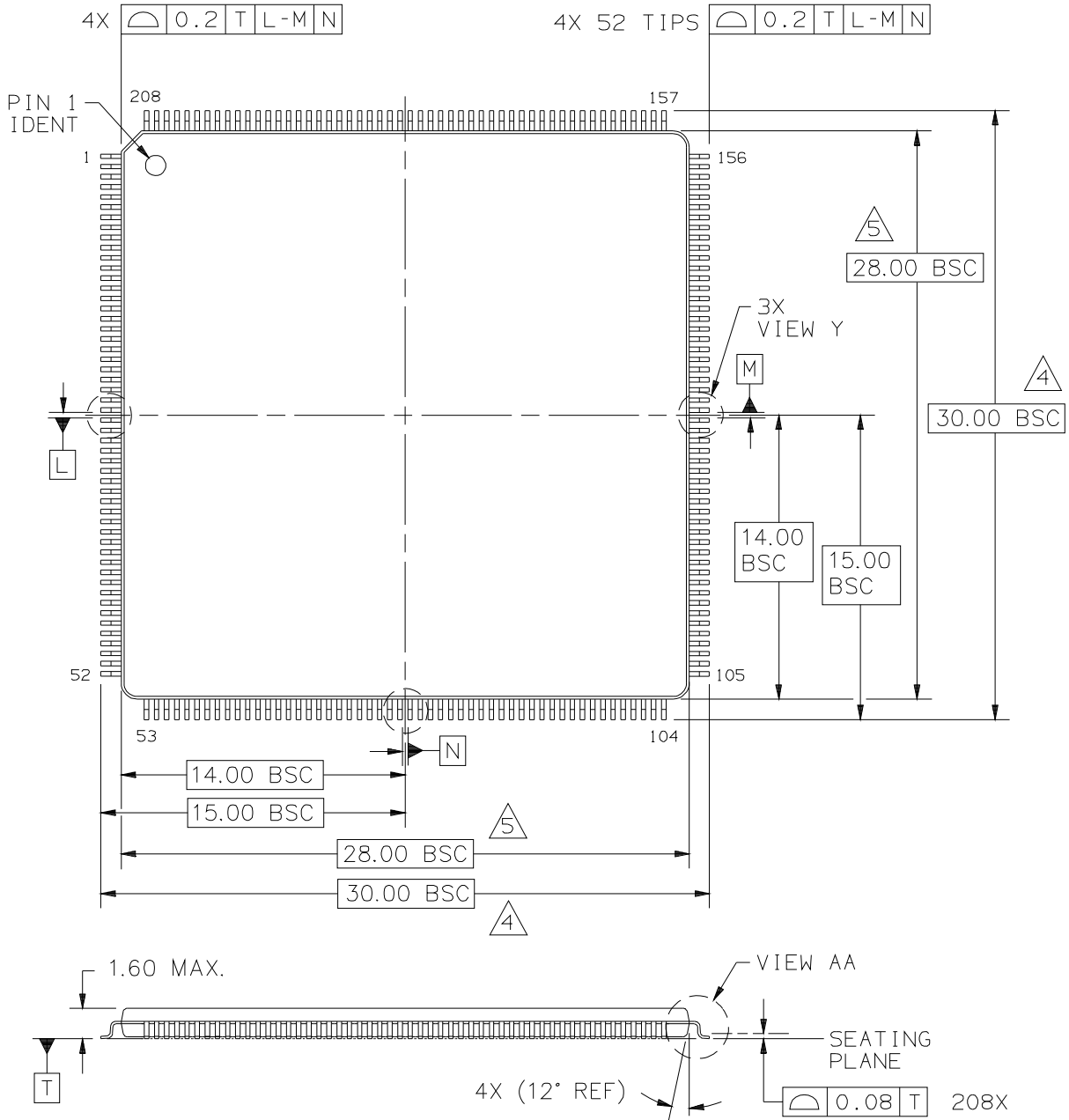

© FREESCALE SEMICONDUCTOR, INC. ALL RIGHTS RESERVED.	MECHANICAL OUTLINE	PRINT VERSION NOT TO SCALE	
TITLE: 208 LD TQFP, 28 X 28 PKG, 0.50 PITCH, 1.4 THICK	DOCUMENT NO: 98ASS23458W	REV: C	
	CASE NUMBER: 998-01	20 MAY 2005	
	STANDARD: JEDEC MS-026 BJB		

Figure 50. LQFP208 mechanical drawing (part 1 of 3)

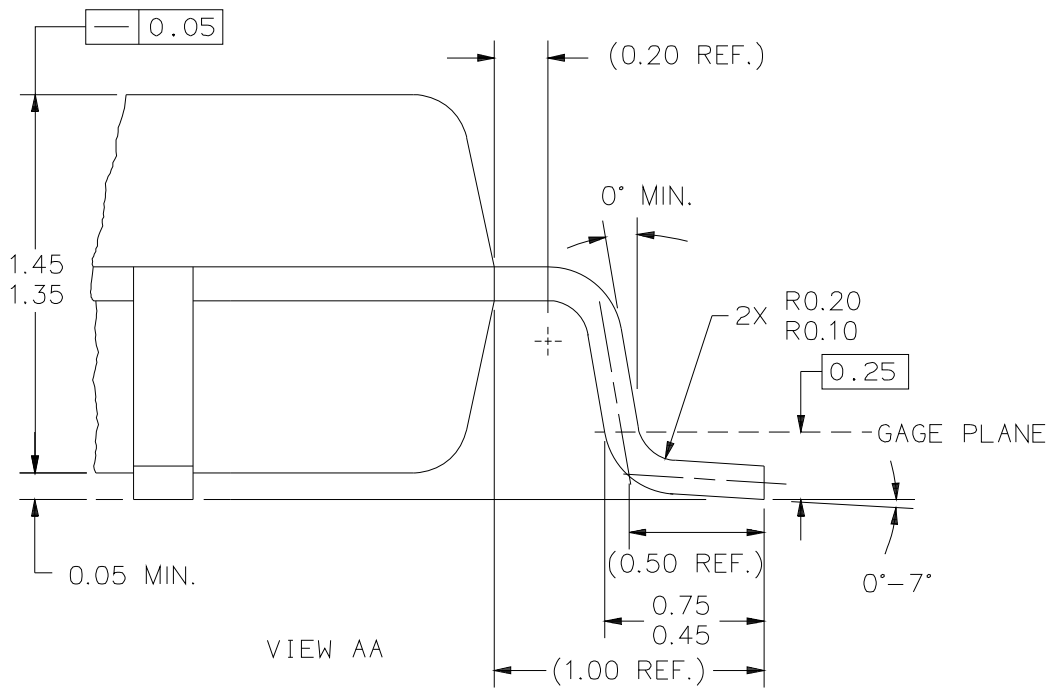
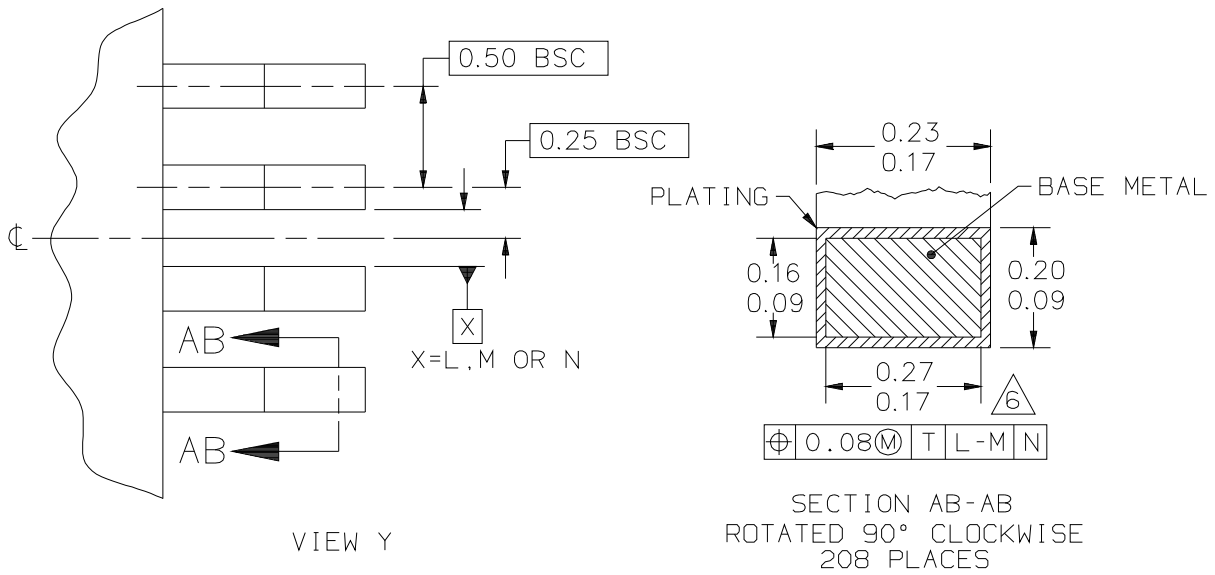

© FREESCALE SEMICONDUCTOR, INC. ALL RIGHTS RESERVED.	MECHANICAL OUTLINE	PRINT VERSION NOT TO SCALE	
TITLE: 208 LD TQFP, 28 X 28 PKG, 0.50 PITCH, 1.4 THICK	DOCUMENT NO: 98ASS23458W	REV: C	
	CASE NUMBER: 998-01	20 MAY 2005	
	STANDARD: JEDEC MS-026 BJB		

Figure 51. LQFP208 mechanical drawing (part 2 of 3)

Package mechanical data

NOTES

1. DIMENSIONS AND TOLERANCING PER ASME Y14.5M-1994.
2. DIMENSIONS IN MILLIMETERS.
3. DATUMS L, M AND N TO BE DETERMINED AT THE SEATING PLANE, DATUM T.
4. DIMENSIONS TO BE DETERMINED AT SEATING PLANE, DATUM T.
5. DIMENSIONS DO NOT INCLUDE MOLD PROTRUSION. ALLOWABLE PROTRUSION IS 0.25 PER SIDE. DIMENSIONS INCLUDE MOLD MISMATCH.
6. DIMENSION DOES NOT INCLUDE DAMBAR PROTRUSION. DAMBAR PROTRUSION SHALL NOT CAUSE THE LEAD WIDTH TO EXCEED 0.35. MINIMUM SPACE BETWEEN PROTRUSION AND ADJACENT LEAD 0.07.

© FREESCALE SEMICONDUCTOR, INC. ALL RIGHTS RESERVED.	MECHANICAL OUTLINE	PRINT VERSION NOT TO SCALE	
TITLE: 208 LD TQFP, 28 X 28 PKG, 0.50 PITCH, 1.4 THICK	DOCUMENT NO: 98ASS23458W	REV: C	
	CASE NUMBER: 998-01	20 MAY 2005	
	STANDARD: JEDEC MS-026 BJB		

Figure 52. LQFP208 mechanical drawing (part 3 of 3)

5.3 416 TEPBGA

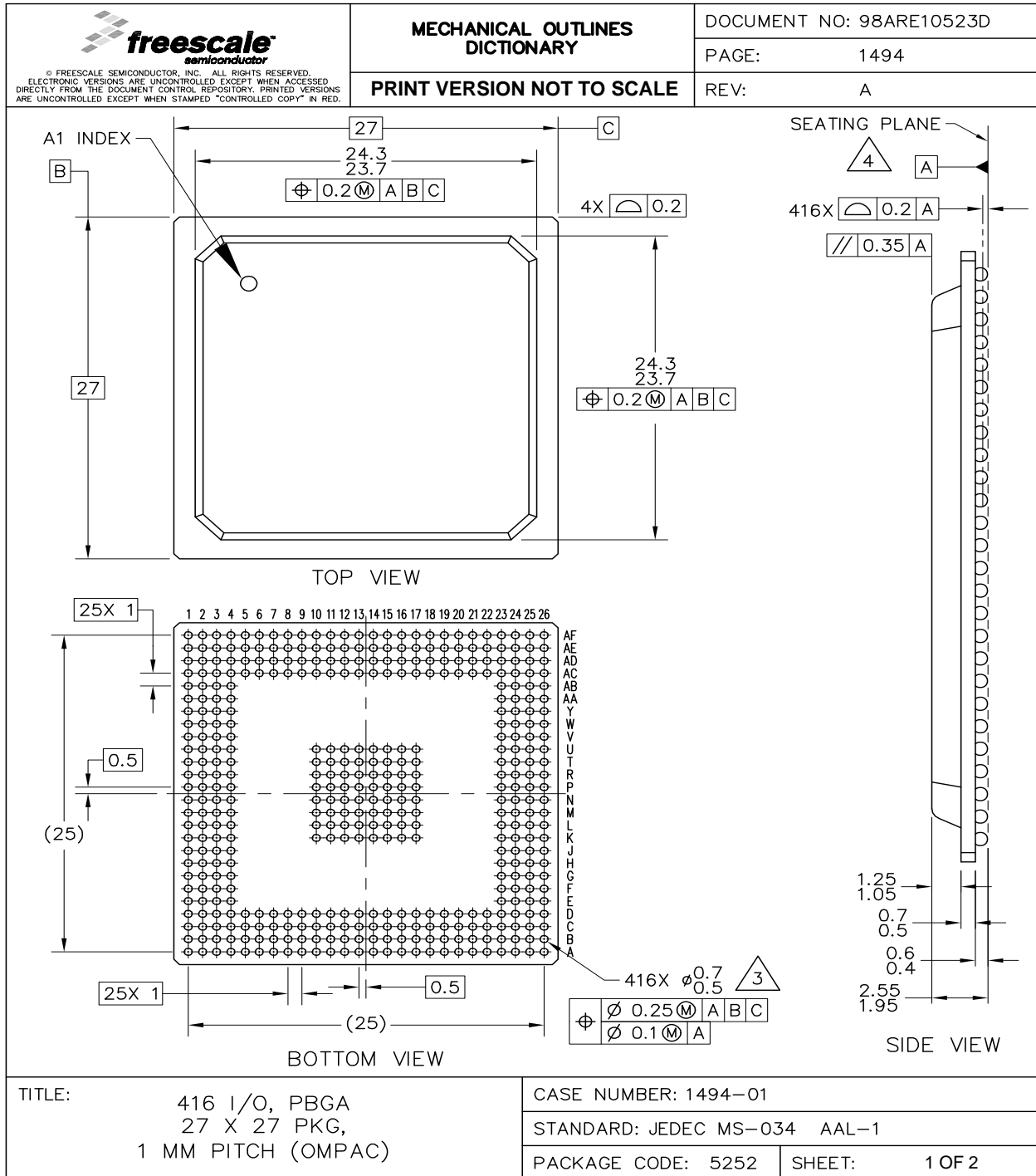

Figure 53. 416 TEPBGA mechanical drawing (part 1 of 2)

Package mechanical data

 <small>© FREESCALE SEMICONDUCTOR, INC. ALL RIGHTS RESERVED. ELECTRONIC VERSIONS ARE UNCONTROLLED EXCEPT WHEN ACCESSED DIRECTLY FROM THE DOCUMENT CONTROL REPOSITORY. PRINTED VERSIONS ARE UNCONTROLLED EXCEPT WHEN STAMPED "CONTROLLED COPY" IN RED.</small>	MECHANICAL OUTLINES DICTIONARY		DOCUMENT NO: 98ARE10523D	
	PRINT VERSION NOT TO SCALE		PAGE:	1494
			REV:	A
<p>NOTES:</p> <ol style="list-style-type: none"> 1. ALL DIMENSIONS IN MILLIMETERS. 2. DIMENSIONING AND TOLERANCING PER ASME Y14.5M-1994. 3. MAXIMUM SOLDER BALL DIAMETER MEASURED PARALLEL TO DATUM A. 4. DATUM A, THE SEATING PLANE, IS DETERMINED BY THE SPHERICAL CROWNS OF THE SOLDER BALLS. 				
TITLE:		416 I/O, PBGA		CASE NUMBER: 1494-01
		27 X 27 PKG,		STANDARD: JEDEC MS-034 AAL-1
		1 MM PITCH (OMPAC)		PACKAGE CODE: 5252

Figure 54. 416 TEPBGA mechanical drawing (part 2 of 2)

6 Ordering information

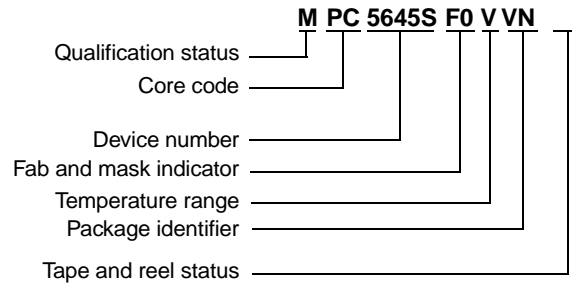

Temperature range

C = -40 to 85
 V = -40 to 105

Package identifier

LU = 176 LQFP Pb-free
 LT = 208 LQFP Pb-free
 VU = 416 TEPBGA Pb-free

Tape and reel status

R = Tape and reel
 (blank) = Trays

Qualification status

P = Pre-qualification
 M = Fully spec. qualified, general market flow
 S = Fully spec. qualified, automotive flow

Note: Not all options are available on all devices. Refer to [Table 73](#).

Figure 55. Commercial product code structure

Table 73. Orderable part number summary

Part number ¹	Flash/SRAM	Package	Speed (MHz)
PPC5645SF0VLUA	2 MB/64 KB	176 LQFP (Pb free)	125
PPC5645SF0VLTA	2 MB/64 KB	208 LQFP (Pb free)	125
PPC5645SF0VVUA	2 MB/64 KB	416 TEPBGA (Pb free)	125

¹ All packaged devices are PPC, rather than MPC or SPC, until product qualifications are complete. The unpackaged device prefix is PCC, rather than SCC, until product qualification is complete. Not all configurations are available in the PPC parts.

7 Revision history

Table 74. Revision history

Revision (Date)	Description
6 (08 Jun 2011)	Initial public release.



THIS PAGE INTENTIONALLY BLANK

How to Reach Us:

Home Page:

www.freescale.com

Web Support:

<http://www.freescale.com/support>

USA/Europe or Locations Not Listed:

Freescale Semiconductor, Inc.
Technical Information Center, EL516
2100 East Elliot Road
Tempe, Arizona 85284
+1-800-521-6274 or +1-480-768-2130
www.freescale.com/support

Europe, Middle East, and Africa:

Freescale Halbleiter Deutschland GmbH
Technical Information Center
Schatzbogen 7
81829 Muenchen, Germany
+44 1296 380 456 (English)
+46 8 52200080 (English)
+49 89 92103 559 (German)
+33 1 69 35 48 48 (French)
www.freescale.com/support

Japan:

Freescale Semiconductor Japan Ltd.
Headquarters
ARCO Tower 15F
1-8-1, Shimo-Meguro, Meguro-ku,
Tokyo 153-0064
Japan
0120 191014 or +81 3 5437 9125
support.japan@freescale.com

Asia/Pacific:

Freescale Semiconductor China Ltd.
Exchange Building 23F
No. 118 Jianguo Road
Chaoyang District
Beijing 100022
China
+86 10 5879 8000
support.asia@freescale.com

Freescale Semiconductor Literature Distribution Center
1-800-441-2447 or +1-303-675-2140
Fax: +1-303-675-2150
LDCForFreescaleSemiconductor@hibbertgroup.com

Document Number: MPC5645S

Rev. 6

08/2011

Information in this document is provided solely to enable system and software implementers to use Freescale Semiconductor products. There are no express or implied copyright licenses granted hereunder to design or fabricate any integrated circuits or integrated circuits based on the information in this document.

Freescale Semiconductor reserves the right to make changes without further notice to any products herein. Freescale Semiconductor makes no warranty, representation or guarantee regarding the suitability of its products for any particular purpose, nor does Freescale Semiconductor assume any liability arising out of the application or use of any product or circuit, and specifically disclaims any and all liability, including without limitation consequential or incidental damages. "Typical" parameters that may be provided in Freescale Semiconductor data sheets and/or specifications can and do vary in different applications and actual performance may vary over time. All operating parameters, including "Typicals", must be validated for each customer application by customer's technical experts. Freescale Semiconductor does not convey any license under its patent rights nor the rights of others. Freescale Semiconductor products are not designed, intended, or authorized for use as components in systems intended for surgical implant into the body, or other applications intended to support or sustain life, or for any other application in which the failure of the Freescale Semiconductor product could create a situation where personal injury or death may occur. Should Buyer purchase or use Freescale Semiconductor products for any such unintended or unauthorized application, Buyer shall indemnify and hold Freescale Semiconductor and its officers, employees, subsidiaries, affiliates, and distributors harmless against all claims, costs, damages, and expenses, and reasonable attorney fees arising out of, directly or indirectly, any claim of personal injury or death associated with such unintended or unauthorized use, even if such claim alleges that Freescale Semiconductor was negligent regarding the design or manufacture of the part.

RoHS-compliant and/or Pb-free versions of Freescale products have the functionality and electrical characteristics as their non-RoHS-compliant and/or non-Pb-free counterparts. For further information, see <http://www.freescale.com> or contact your Freescale sales representative.

For information on Freescale's Environmental Products program, go to <http://www.freescale.com/epp>.

Freescale™ and the Freescale logo are trademarks of Freescale Semiconductor, Inc. All other product or service names are the property of their respective owners.
© Freescale Semiconductor, Inc. 2010-2011. All rights reserved.

