

**Single N-Channel, 20V, 0.95A, Power MOSFET**

V <sub>DS</sub> (V)	R <sub>ds(on)</sub> (Ω)
20	0.210@ V <sub>GS</sub> =4.5V
	0.250@ V <sub>GS</sub> =2.5V
	0.305@ V <sub>GS</sub> =1.8V
ESD Protected	



**SOT-723**

**Descriptions**

The WNM2030 is N-Channel enhancement MOS Field Effect Transistor. Uses advanced trench technology and design to provide excellent R<sub>DS (ON)</sub> with low gate charge. This device is suitable for use in DC-DC conversion, power switch and charging circuit. Standard Product WNM2030 is Pb-free.

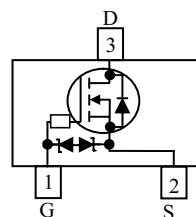

**Pin configuration (Top view)**

**Features**

- Trench Technology
- Supper high density cell design
- Excellent ON resistance for higher DC current
- Extremely Low Threshold Voltage
- Small package SOT-723

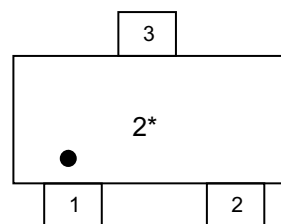

2 = Device Code  
\* = Month (A~Z)

**Marking**

**Applications**

- Driver for Relay, Solenoid, Motor, LED etc.
- DC-DC converter circuit
- Power Switch
- Load Switch
- Charging

**Order information**

Device	Package	Shipping
WNM2030-3/TR	SOT-723	8000/Reel&Tape

**Absolute Maximum ratings**

Parameter		Symbol	10 S	Steady State	Unit
Drain-Source Voltage		$V_{DS}$	20		V
Gate-Source Voltage		$V_{GS}$	$\pm 6$		
Continuous Drain Current <sup>a</sup>	$T_A=25^\circ\text{C}$	$I_D$	0.95	0.88	A
	$T_A=70^\circ\text{C}$		0.76	0.71	
Maximum Power Dissipation <sup>a</sup>	$T_A=25^\circ\text{C}$	$P_D$	0.43	0.37	W
	$T_A=70^\circ\text{C}$		0.28	0.24	
Continuous Drain Current <sup>b</sup>	$T_A=25^\circ\text{C}$	$I_D$	0.80	0.75	A
	$T_A=70^\circ\text{C}$		0.64	0.60	
Maximum Power Dissipation <sup>b</sup>	$T_A=25^\circ\text{C}$	$P_D$	0.31	0.27	W
	$T_A=70^\circ\text{C}$		0.20	0.17	
Pulsed Drain Current <sup>c</sup>		$I_{DM}$	1.5		A
Operating Junction Temperature		$T_J$	150		$^\circ\text{C}$
Lead Temperature		$T_L$	260		$^\circ\text{C}$
Storage Temperature Range		$T_{stg}$	-55 to 150		$^\circ\text{C}$

**Thermal resistance ratings**

Parameter		Symbol	Typical	Maximum	Unit
Junction-to-Ambient Thermal Resistance <sup>a</sup>	$t \leq 10 \text{ s}$	$R_{\theta JA}$	225	285	$^\circ\text{C/W}$
	Steady State		270	330	
Junction-to-Ambient Thermal Resistance <sup>b</sup>	$t \leq 10 \text{ s}$	$R_{\theta JA}$	330	400	
	Steady State		390	460	
Junction-to-Case Thermal Resistance		$R_{\theta JC}$	230	265	

a Surface mounted on FR-4 Board using 1 square inch pad size, 1oz copper

b Surface mounted on FR-4 board using minimum pad size, 1oz copper

c Pulse width < 380 $\mu\text{s}$ , Duty Cycle < 2%

d Maximum junction temperature  $T_J=150^\circ\text{C}$ .

**Electronics Characteristics (Ta=25°C, unless otherwise noted)**

Parameter	Symbol	Test Conditions	Min	Typ	Max	Unit
<b>OFF CHARACTERISTICS</b>						
Drain-to-Source Breakdown Voltage	$BV_{DSS}$	$V_{GS} = 0\text{ V}, I_D = 250\mu\text{A}$	20			V
Zero Gate Voltage Drain Current	$I_{DSS}$	$V_{DS} = 16\text{V}, V_{GS} = 0\text{V}$			1	$\mu\text{A}$
Gate-to-source Leakage Current	$I_{GSS}$	$V_{DS} = 0\text{ V}, V_{GS} = \pm 5\text{V}$			$\pm 5$	$\mu\text{A}$
<b>ON CHARACTERISTICS</b>						
Gate Threshold Voltage	$V_{GS(TH)}$	$V_{GS} = V_{DS}, I_D = 250\mu\text{A}$	0.45	0.65	1.0	V
Drain-to-source On-resistance <sup>b, c</sup>	$R_{DS(on)}$	$V_{GS} = 4.5\text{V}, I_D = 0.55\text{A}$		210	310	m $\Omega$
		$V_{GS} = 2.5\text{V}, I_D = 0.50\text{A}$		250	360	
		$V_{GS} = 1.8\text{V}, I_D = 0.35\text{A}$		305	460	
<b>CAPACITANCES, CHARGES</b>						
Input Capacitance	$C_{ISS}$	$V_{GS} = 0\text{ V},$ $f = 100\text{KHz},$ $V_{DS} = 10\text{ V}$		50		pF
Output Capacitance	$C_{OSS}$			13		
Reverse Transfer Capacitance	$C_{RSS}$			8		
Total Gate Charge	$Q_{G(TOT)}$	$V_{GS} = 4.5\text{ V},$ $V_{DS} = 10\text{ V},$ $I_D = 0.55\text{A}$		1.15		nC
Threshold Gate Charge	$Q_{G(TH)}$			0.06		
Gate-to-Source Charge	$Q_{GS}$			0.15		
Gate-to-Drain Charge	$Q_{GD}$			0.23		
<b>SWITCHING CHARACTERISTICS</b>						
Turn-On Delay Time	$t_d(ON)$	$V_{GS} = 4.5\text{ V},$ $V_{DD} = 10\text{ V},$ $I_D = 0.55\text{ A},$ $R_G = 6\ \Omega$		22		ns
Rise Time	$t_r$			80		
Turn-Off Delay Time	$t_d(OFF)$			700		
Fall Time	$t_f$			380		
<b>BODY DIODE CHARACTERISTICS</b>						
Forward Voltage	$V_{SD}$	$V_{GS} = 0\text{ V}, I_S = 0.35\text{A}$	0.5	0.7	1.5	V

Typical Characteristics (Ta=25°C, unless otherwise noted)

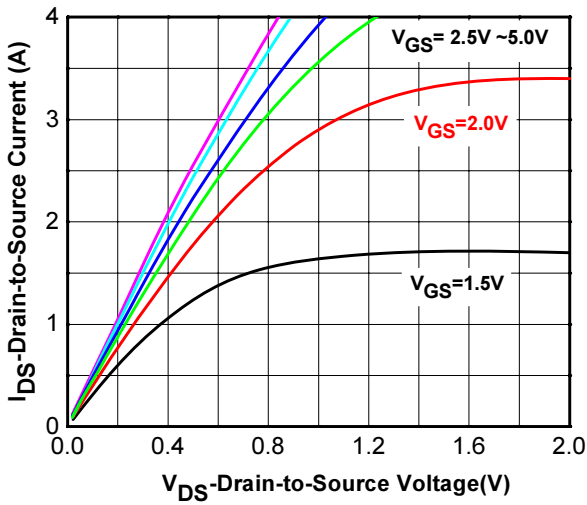

Output Characteristics

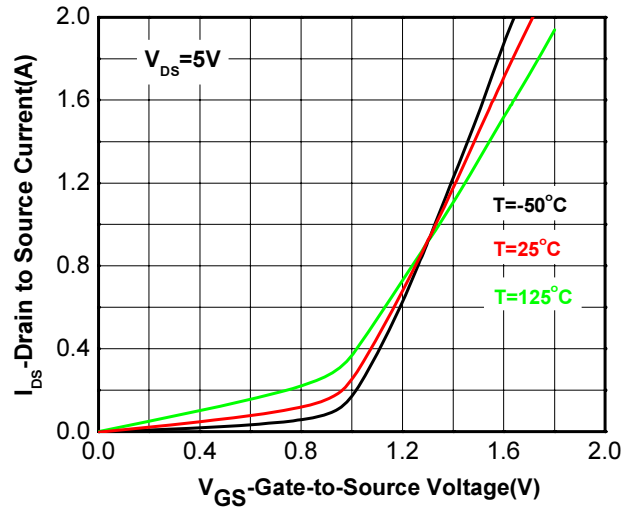

Transfer Characteristics

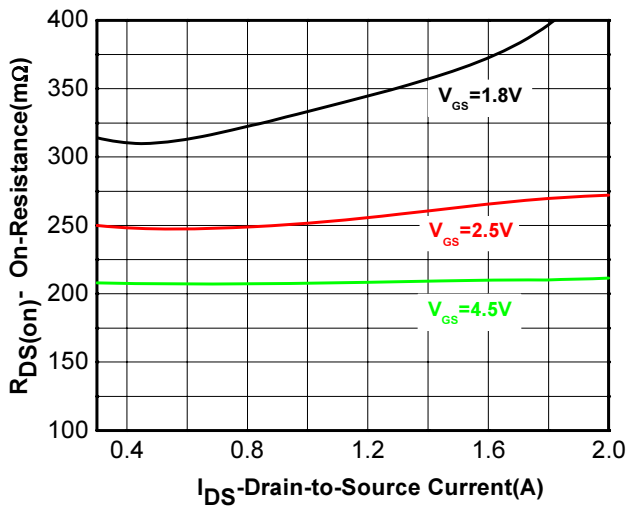

On Resistance vs. Drain Current

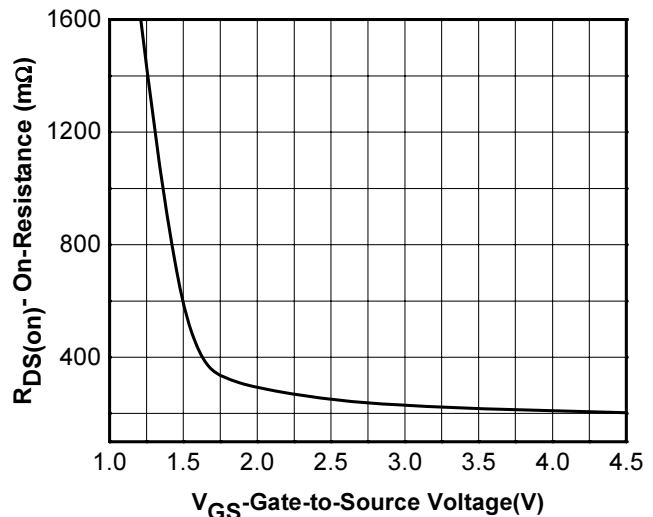

On Resistance vs.  $V_{GS}$  vs. Temperature

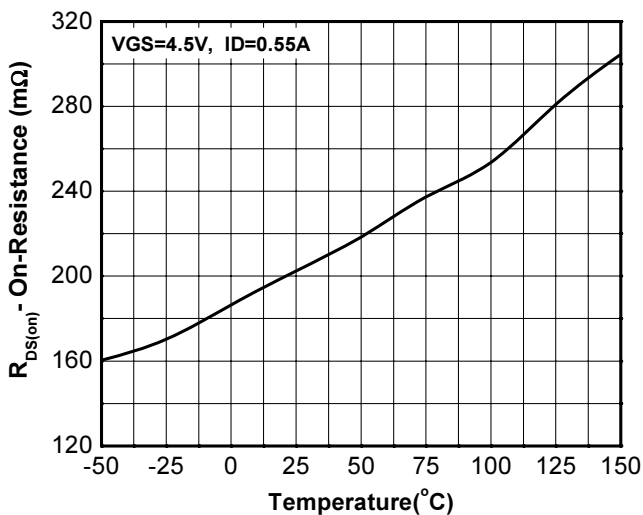

On Resistance vs. Junction Temperature

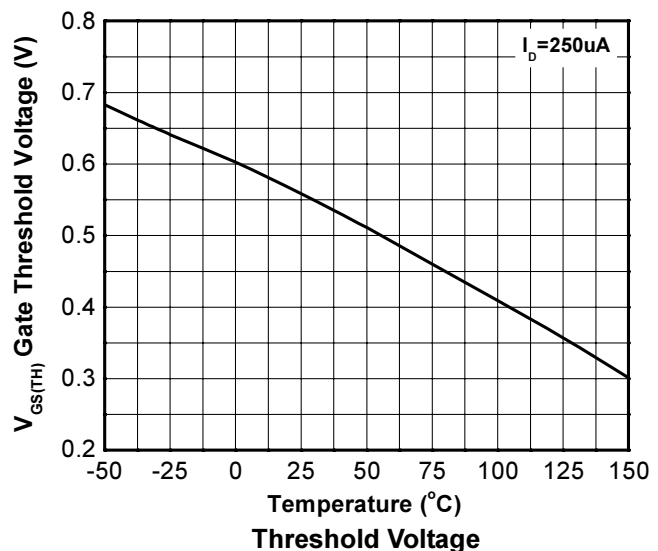

Threshold Voltage

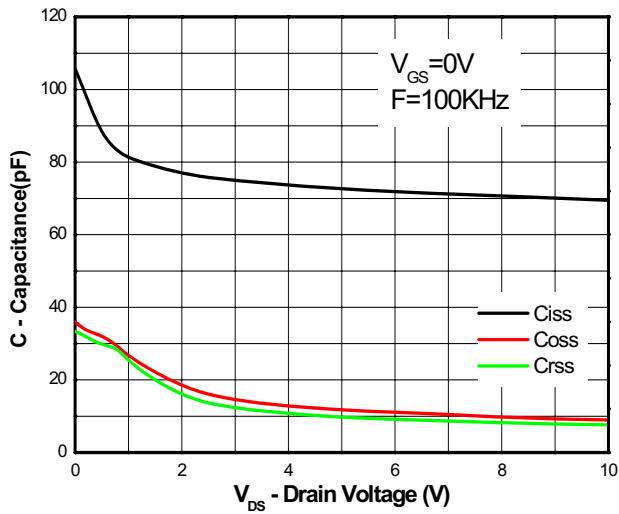

Capacitance

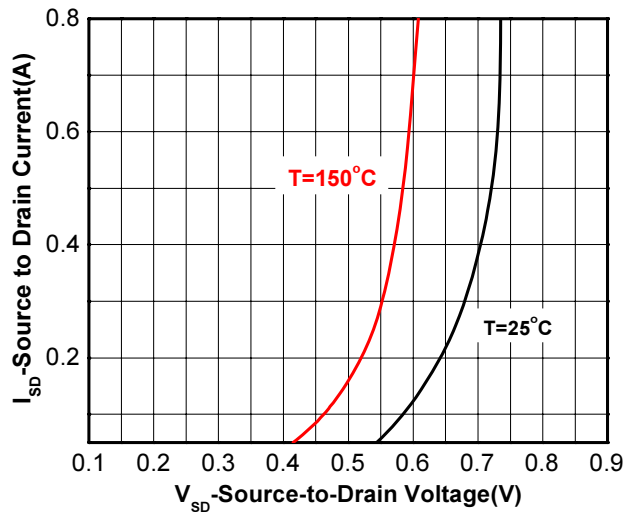

Body diode forward voltage

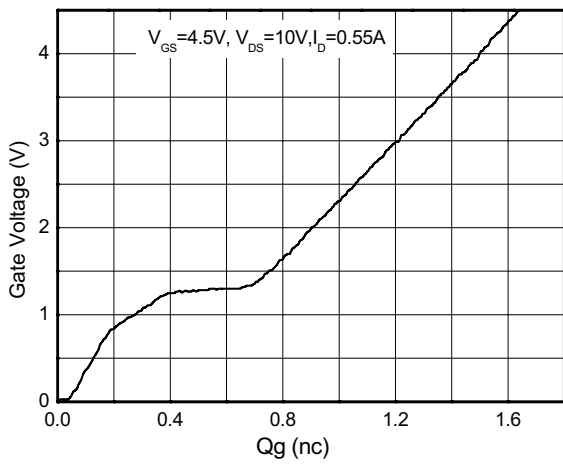

Gate Charge Characteristics

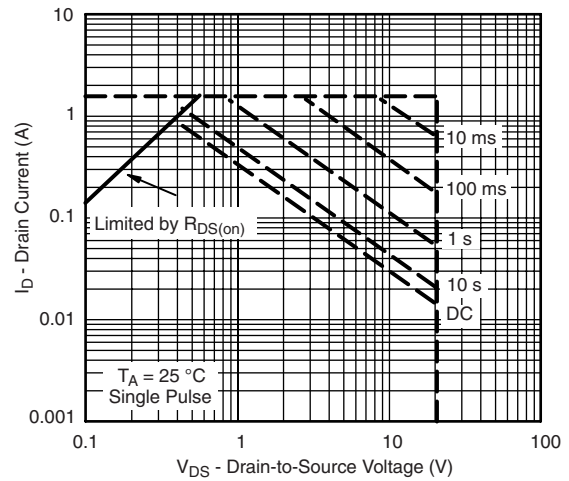

Safe operating power

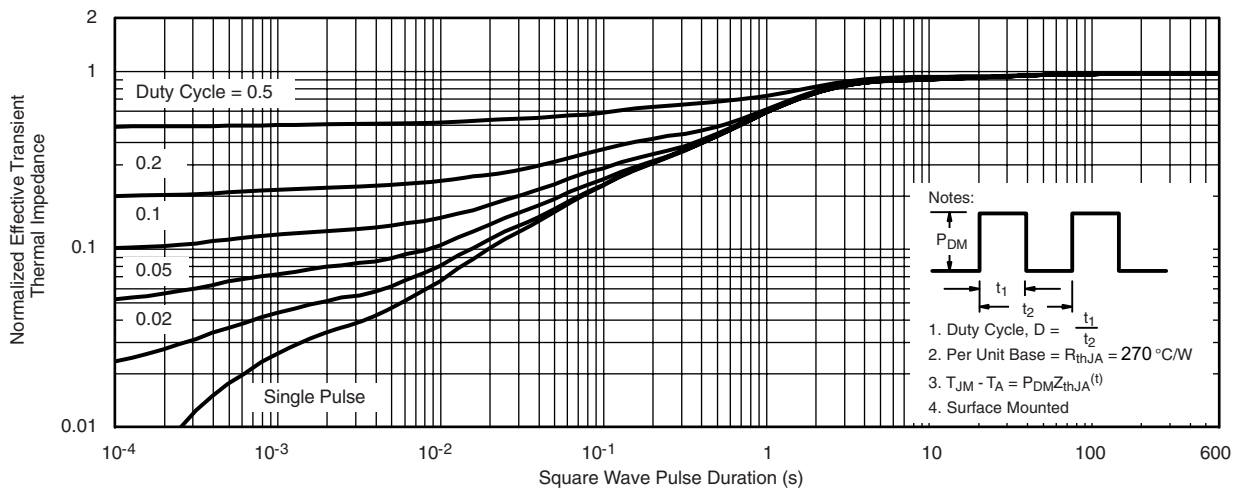

Transient thermal response (Junction-to-Ambient)

Package outline dimensions

SOT-723

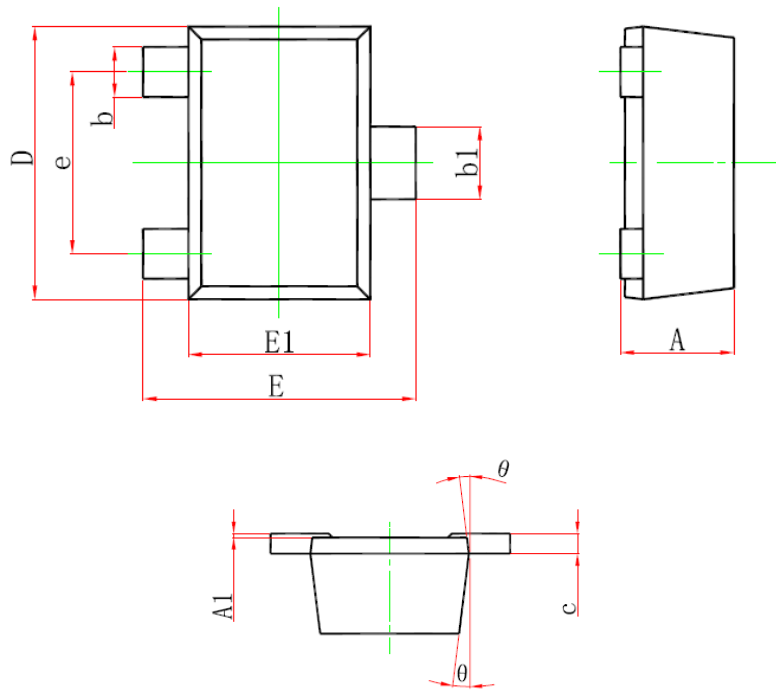

Symbol	Dimension in Millimeters	
	Min.	Max.
A		0.500
A1	0.000	0.050
b	0.170	0.270
b1	0.270	0.370
c		0.150
D	1.150	1.250
E	1.150	1.250
E1	0.750	0.850
e	0.800 TYP	
θ	7° REF.	