

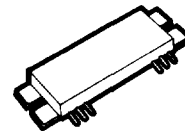
**The RF Line**  
**UHF Power Amplifiers**

... designed for wide power range control as encountered in UHF cellular radio applications.

- MX20-1 400–440 MHz  
 MX20-2 440–470 MHz
- Specified 12.5 V, UHF Characteristics —  
 Output Power — 20 W  
 Minimum Gain — 21 dB  
 Harmonics — -40 dBc Max
- 50 Ohm Input/Output Impedances
- *Guaranteed Stability and Ruggedness*

**MX20-1**  
**MX20-2**

**20 WATTS**  
**400–470 MHz**  
**RF POWER AMPLIFIERS**



**CASE 830-01, STYLE 1**  
**(MVM)**

**MAXIMUM RATINGS**

Rating	Symbol	Value	Unit
DC Supply Voltages	$V_{CC1}, V_{CC2}$	15.6	Vdc
Operating Case Temperature Range	$T_C$	-30 to +100	°C
Storage Temperature Range	$T_{stg}$	-40 to +100	°C

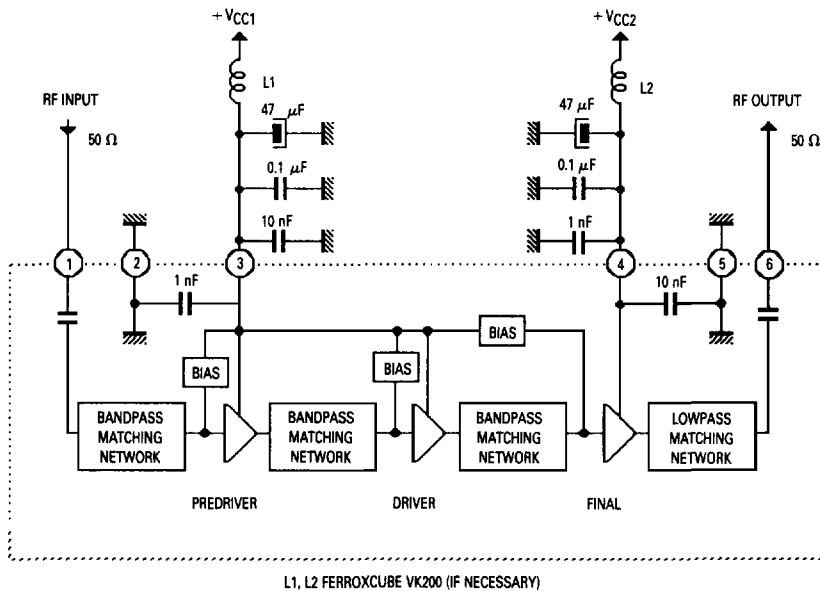
**THERMAL CHARACTERISTICS**

Characteristic	Symbol	Typ	Unit
Thermal Resistance, Junction to Flange	$R_{\theta JF}$	4	°C/W

**ELECTRICAL CHARACTERISTICS** ( $V_{CC1}$  and  $V_{CC2}$  set at 12.5 Vdc,  $T_A = 25^\circ\text{C}$ , 50  $\Omega$  system unless otherwise noted.)

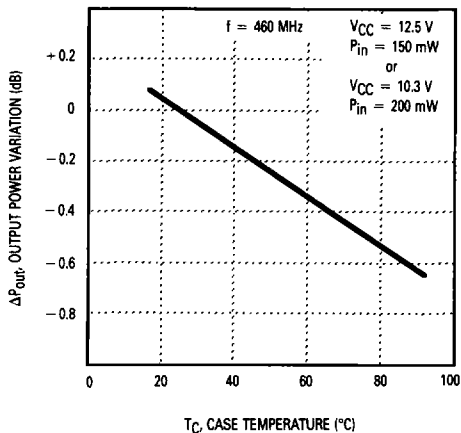
Characteristic	Symbol	Min	Typ	Max	Unit
Frequency Range MX20-1 MX20-2	—	400 440	— —	440 470	MHz
Input Power ( $P_O = 20$ W)	$P_{in}$	—	—	150	mW
Power Gain ( $P_O = 20$ W)	$G_p$	21	—	—	dB
Efficiency ( $P_O = 20$ W)	$\eta$	35	40	—	%
Harmonics ( $P_O = 20$ W, Reference)	—	—	—	-40	dBc
Input Return Loss	$\Gamma_{IN}$	10	—	—	dB
Power Derating ( $P_O = 20$ W, $T_C = 25^\circ\text{C}$ Ref.) -30°C to +70°C	—	—	—	1	dB
Load Mismatch ( $V_{CC} = 15.6$ V, $P_O \leq 30$ W, $P_{in} \leq 200$ mW, Load VSWR 20:1, All Phase Angles)	$\psi$	No change in $P_{Out}$ Before and After Test			
Stability ( $P_{in} = 0$ to 200 mW; Load Mismatch 4:1; $V_{CC2} = 0$ to 15.6 Vdc; $V_{CC1}$ adjusted to keep $P_O \leq 20$ W)	—	All spurious outputs more than 70 dB below desired signal			
Gain Control Range	—	30	—	—	dB

# MX20-1, MX20-2

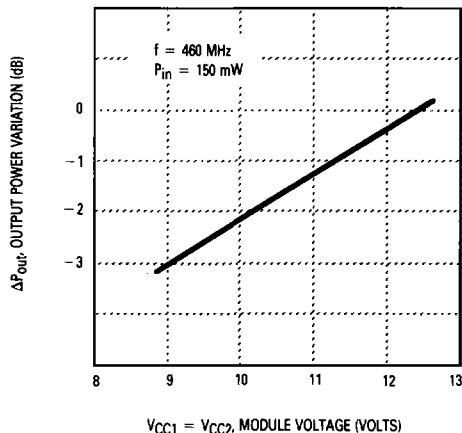


**Figure 1. UHF Module Test Setup**

5

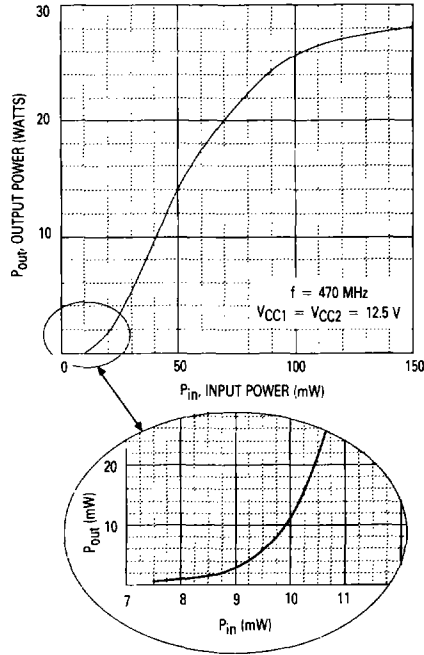


**Figure 2. Output Power Variation versus Temperature**

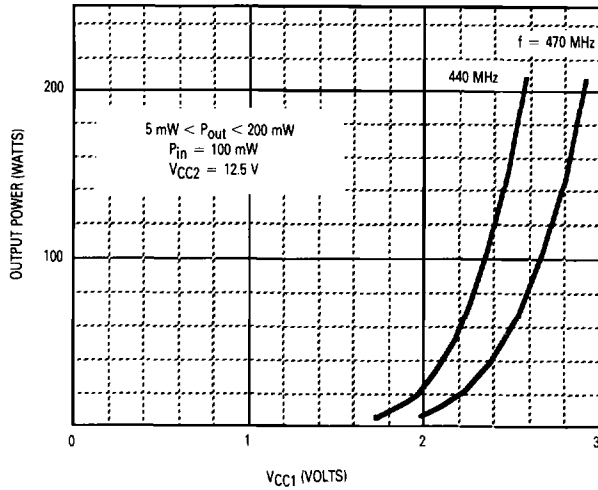


**Figure 3. Output Power Variation versus Voltage**

# MX20-1, MX20-2



**Figure 4. Output Power versus Input Power**



**Figure 5. Output Power versus Control Voltage**