

DWDM 40KM SFP+ TRANSCEIVERS

TPD1XGJERxx



Product Description

The TPD1XGJERxx is an enhanced small form factor pluggable (SFP+) fiber optic transceiver with digital diagnostics monitoring functionality (DDM). Supporting Ethernet and Fiber Channel standards with dense wavelength division multiplexing (DWDM) wavelength makes it ideally suited for high capacity data-com and storage area network applications. DDM functionality (alarm and warning features) is integrated into the design via an I²C serial interface per the Multi-Source Agreement (MSA) SFF-8472, Rev. 10.4.

Each transceiver utilizes an electro absorption modulator integrated laser (EML) with an operating wavelength with 100GHz (0.8nm) spacing per the ITU-grid. The transceiver supports data rates ranging from 11.3Gbps down to 8Gbps. It provides an excellent solution for data transmission at DWDM wavelength over up to 40km single mode fiber. The low power consumption and excellent EMI performance enable system design with high port density. The product is RoHS compliant and is designed and tested in accordance with industry safety standards. The transceiver is Class I Laser product per U.S. FDA/CDRH and international IEC-60825 standards.

The TPD1XGJERxx transceiver connects to standard 20-pad SFP+ connectors for hot plug capability. This allows the system designer to make configuration changes or maintenance by simply plugging in different transceivers without removing the power supply from the host system. The transmitter and receiver DATA interfaces are internally AC-coupled. LV-TTL Transmitter Disable control input and Loss of Signal (LOS) output interfaces are also provided. The transceiver has bail-type latch, which offers an easy and convenient way to release the modules.

The transceiver operates from a single +3.3V power supply over an operating case temperature range of -5°C to +70°C (Commercial), or -5°C to +85°C (Extended) or -40°C to +85°C (Industrial).



Features

- ☑ Temperature-stabilized DWDM EML transmitter
- ☑ Multi-rate for Ethernet & Fiber Channel
- ☑ Transmission distance up to 40km (SM Fiber)
- ☑ Low power consumption
- ☑ Wide case operating temperature range
- ☑ Compliant to SFP+ Electrical MSA SFF-8431
- ☑ Compliant to SFP+ Mechanical MSA SFF-8432
- ☑ Compliant to 10GBASE-E specifications
- ☑ Digital Diagnostics Monitoring (DDM) through Serial Interface comply with SFF-8472, Rev. 10.4
- ☑ RoHS 6/6 Compliant
- ☑ Laser Class 1 IEC/CDRH compliant

Absolute Maximum Ratings

| Parameter | Symbol | Minimum | Maximum | Units |
|--|--------------|---------|---------|-------|
| Storage Temperature Range | T_{ST} | - 40 | + 85 | °C |
| Operating Case Temperature ¹ | "Commercial" | - 5 | + 70 | °C |
| | "Extended" | - 5 | + 85 | |
| | "Industrial" | - 40 | + 85 | |
| Operating Relative Humidity ² | RH | 0 | 85 | % |
| Supply Voltage Range | V_{CC} | - 0.5 | + 3.6 | V |

¹ Measured on top side of SFP+ module at the front center vent hole of the cage.

² Non condensing

Transmitter Performance Characteristics (Over Operating Case Temperature. $V_{CC} = 3.13$ to $3.47V$)

| Parameter | Symbol | Minimum | Typical | Maximum | Units |
|--|------------------------------------|--------------------------------|---------|---------|-------|
| Data Rate | B | 8.0 | - | 11.3 | Gb/s |
| Center Wavelength ¹ | λ_c | See Ordering Information Table | | | nm |
| Spectral Width (-20dB) | $\Delta\lambda_{20}$ | - | - | 1.0 | nm |
| Average Optical Output Power ² | P_{Avg} | 0 | - | + 4 | dBm |
| Optical Modulation Amplitude | P_{OMA} | 0 | - | - | dBm |
| Extinction Ratio | ER | 4.5 | - | - | dB |
| Relative Intensity Noise in OMA | $RIN_{21,OMA}$ | - | - | - 128 | dB/Hz |
| Side Mode Suppression Ratio | $SMSR$ | 30 | - | - | dB |
| Optical Return Loss Tolerance | - | - | - | - 21 | dB |
| Transmitter and Dispersion Penalty @ 10.3125Gb/s | TDP | - | - | 3 | dB |
| Optical Output Eye | <i>Compliant with IEEE 802.3ae</i> | | | | |

¹ BOL : $\pm 0.05nm$ from ITU grid; EOL: $\pm 0.1nm$ from ITU grid.
² Average power figures are informative only, per IEEE 802.3ae.

Receiver Performance Characteristics (Over Operating Case Temperature. $V_{CC} = 3.13$ to $3.47V$)

| Parameter | Symbol | Minimum | Typical | Maximum | Units |
|---|--------------------------------|------------|---------|---------|-------|
| Data Rate | B | 8.0 | - | 11.3 | Gb/s |
| Wavelength of Operation | λ | 1530 | - | 1565 | nm |
| Receiver Sensitivity | OMA @ 10.3125Gb/s ¹ | P_{min} | - | - 14.1 | dBm |
| Stressed Receiver Sensitivity in OMA (@ 10.3125Gb/s) ² | - | - | - | - 11.3 | dBm |
| Maximum Input Optical Power (10^{-12} BER) | P_{max} | - 1 | - | - | dBm |
| Receiver Reflectance | - | - | - | - 26 | dB |
| LOS Hysteresis | - | 0.5 | - | - | dB |
| LOS Thresholds | Increasing Light Input | P_{los+} | - | - 16 | dBm |
| | Decreasing Light Input | P_{los-} | - 30 | - | |

¹ Specified with BER $< 1 \times 10^{-12}$ and PRBS 2³¹-1.
² Comply with IEEE 802.3ae

Note: The specified characteristics are met within the recommended range of operation. Unless otherwise noted typical data are quoted at nominal voltage and +25°C ambient temperature.

Laser Safety:

All transceivers are Class 1 Laser products per FDA/CDRH and IEC-60825 standards. They must be operated under specified operating conditions.



Oplink Communications, Inc.

This product complies with
 21 CFR 1040.10 and 1040.11
Meets Class 1 Laser Safety Requirements

Module Pin Description

| Pin | Logic | Symbol | Description |
|-----|-----------|-------------------|---|
| 1 | - | <i>VeeT</i> | Module Transmitter Ground |
| 2 | LVTTL-O | <i>TX_Fault</i> | Module Transmitter Fault |
| 3 | LVTTL-I | <i>TX_Disable</i> | Transmitter Disable; Turns off transmitter laser output |
| 4 | LVTTL-I/O | <i>SDA</i> | 2-Wire Serial Interface Data Line |
| 5 | LVTTL-I/O | <i>SCL</i> | 2-Wire Serial Interface Clock |
| 6 | - | <i>MOD-ABS</i> | Module Definition, Grounded in the module |
| 7 | LVTTL-I | <i>RS0</i> | No function implemented |
| 8 | LVTTL-O | <i>RX_LOS</i> | Receiver Loss of Signal Indication |
| 9 | LVTTL-I | <i>RS1</i> | No function implemented |
| 10 | - | <i>VeeR</i> | Module Receiver Ground |
| 11 | - | <i>VeeR</i> | Module Receiver Ground |
| 12 | CML-O | <i>RD-</i> | Receiver Inverted Data Output |
| 13 | CML-O | <i>RD+</i> | Receiver Data Output |
| 14 | - | <i>VeeR</i> | Module Receiver Ground |
| 15 | - | <i>VccR</i> | Module Receiver 3.3V Supply |
| 16 | - | <i>VccT</i> | Module Transmitter 3.3V Supply |
| 17 | - | <i>VeeT</i> | Module Transmitter Ground |
| 18 | CML-I | <i>TD+</i> | Transmitter Non-Inverted Data Input |
| 19 | CML-I | <i>TD-</i> | Transmitter Inverted Data Input |
| 20 | - | <i>VeeT</i> | Module Transmitter Ground |

Application Notes

Electrical Interface: All signal interfaces are compliant with the SFP+ MSA specification. The high speed DATA interface is differential AC-coupled internally and can be directly connected to a 3.3V SERDES IC. All low speed control and sense output signals are open collector TTL compatible and should be pulled up with a 4.7k Ω - 10k Ω resistor on the host board.

Loss of Signal (LOS): The Loss of Signal circuit monitors the level of the incoming optical signal and generates logic HIGH when an insufficient photocurrent is produced.

TX_Fault: The output indicates LOW when the transmitter is operating normally and HIGH with a laser fault including laser end-of-life. TX Fault is an open collector/drain output and should be pulled up with a 4.7k Ω - 10k Ω resistor on the host board.

TX_Disable: When the TX Disable pin is at logic HIGH, the transmitter optical output is disabled. The laser is also disabled if this line is left floating, as it is pulled high inside the transceiver.

Serial Identification and Monitoring: The module definition of SFP is indicated by the MOD_ABS pin and the

2-wire serial interface. Upon power up, the 2-wire interface appears as NC (no connection), and MOD_ABS is TTL LOW. When the host system detects this condition, it activates the serial protocol (standard two-wire I²C serial interface) and generates the serial clock signal (SCL). The positive edge clocks data into the EEPROM segments of the device that are not write protected, and the negative edge clocks data from the device. The serial data signal (SDA) is for serial data transfer. The host uses SDA in conjunction with SCL to mark the start and end of serial protocol activation. The supported monitoring functions are temperature, voltage, bias current, transmitter power, average receiver signal, all alarms and warnings, and software monitoring of TX Fault/LOS. The device is internally calibrated.

The data transfer protocol and the details of the mandatory and vendor specific data structures are defined in the SFP MSA, and SFF-8472, Rev. 10.4.

Power Supply and Grounding: The power supply line should be well-filtered. All power supply bypass capacitors should be as close to the transceiver module as possible.

Interfacing the Transceivers

Communication is via a serial 2-wire serial interface. As described in the document SFF-8472 (REV. 10.4) there are two distinct address spaces:

| Base Address A0(hex) | |
|----------------------|---|
| Byte Address | Content |
| 0 – 95 | Serial Transceiver ID as defined in SFP MSA |
| 96 – 127 | OPLINK Specific |
| 128 – 255 | Reserved |

| Base Address A2(hex) | |
|----------------------|---|
| Byte Address | Content |
| 0 - 55 | Alarm & Warnings thresholds & limits |
| 56 - 95 | External calibration constants (not used) |
| 96 – 119 | Values from real time diagnostic monitoring |
| 120 – 127 | Not used |
| 128 – 247 | Customer specific, writable area |
| 248 - 255 | Not used |

Application Schematics Recommended electrical connections to transceiver are shown below.

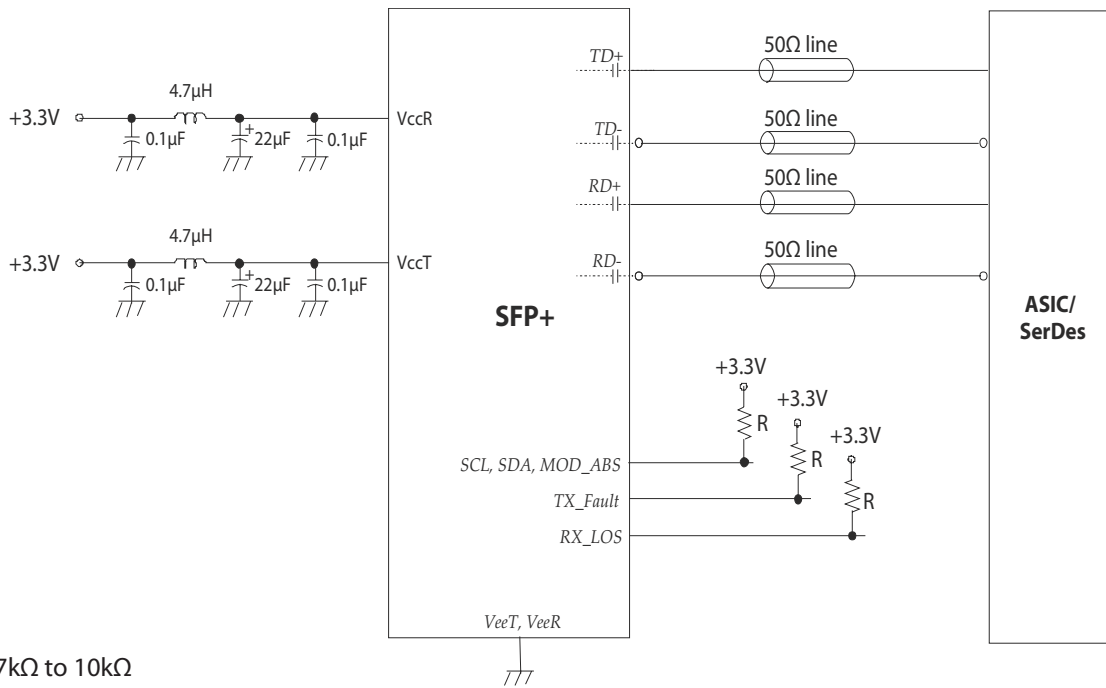

ESD & Electromagnetic Compatibility

| Requirements | Standard | Status |
|---|--|---|
| Electro Static Discharge to the Electrical Pins (ESD) | EIA/JESD22-A114-B MIL-STD 883C Method 3015.7 | Exceeds requirements Class 1B (>1000V) |
| Immunity to ESD (housing, receptacle) | IEN 61000-4-2 | Exceeds requirements Discharges ranging from 2kV to 15kV without damages to the transceiver |
| Electromagnetic Emission (EMI) | FCC Part 15, Class B EN 55022 Class B CISPR 22 | Exceeds requirements Class B |

Package Outline

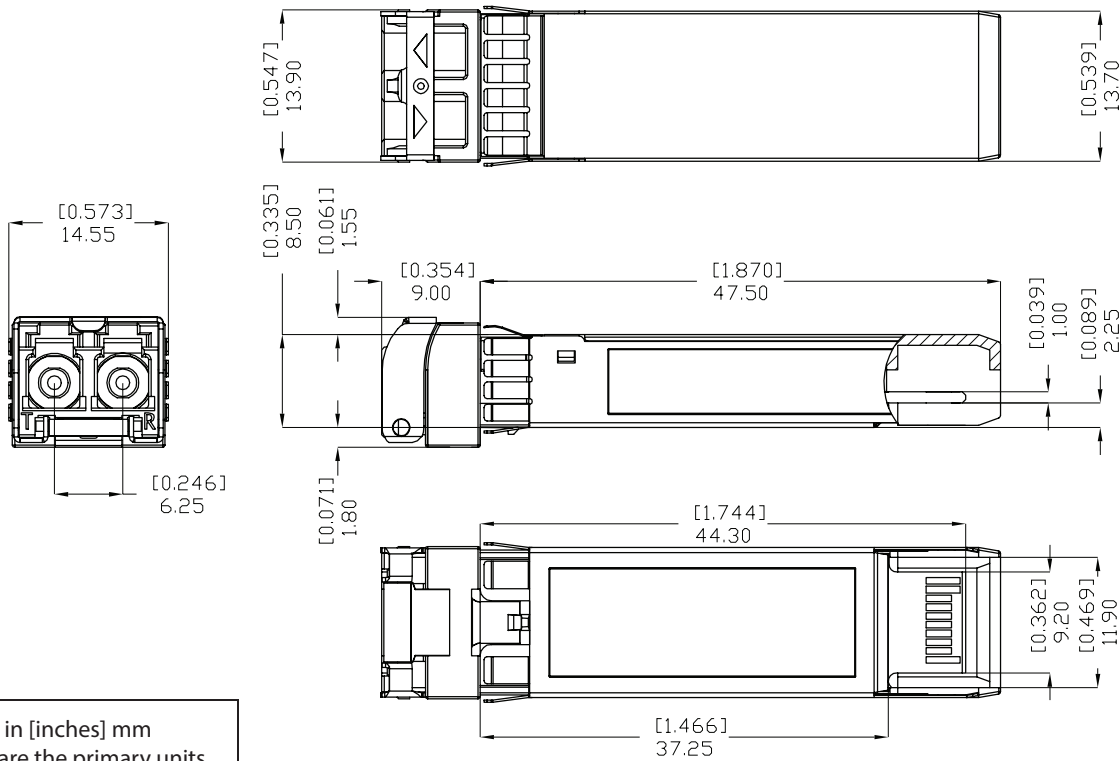

Dimensions in [inches] mm
 Millimeters are the primary units.
 Tolerances are in accordance with
 SFF-8432 Rev.5

Ordering Information

| Model Name | Operating Temperature | | Center Wavelength (nm) | ITU Frequency (THz) | Wavelength Reference | Distance |
|------------------|-----------------------|------------|------------------------|---------------------|----------------------|----------|
| TPD1XGJERC00061G | -5°C to +70°C | Commercial | 1528.77 | 196.1 | 61 | 40km |
| TPD1XGJERC00060G | -5°C to +70°C | Commercial | 1529.55 | 196.0 | 60 | 40km |
| TPD1XGJERC00059G | -5°C to +70°C | Commercial | 1530.33 | 195.9 | 59 | 40km |
| TPD1XGJERC00058G | -5°C to +70°C | Commercial | 1531.12 | 195.8 | 58 | 40km |
| TPD1XGJERC00057G | -5°C to +70°C | Commercial | 1531.90 | 195.7 | 57 | 40km |
| TPD1XGJERC00056G | -5°C to +70°C | Commercial | 1532.68 | 195.6 | 56 | 40km |
| TPD1XGJERC00055G | -5°C to +70°C | Commercial | 1533.47 | 195.5 | 55 | 40km |
| TPD1XGJERC00054G | -5°C to +70°C | Commercial | 1534.25 | 195.4 | 54 | 40km |
| TPD1XGJERC00053G | -5°C to +70°C | Commercial | 1535.04 | 195.3 | 53 | 40km |
| TPD1XGJERC00052G | -5°C to +70°C | Commercial | 1535.82 | 195.2 | 52 | 40km |
| TPD1XGJERC00051G | -5°C to +70°C | Commercial | 1536.61 | 195.1 | 51 | 40km |
| TPD1XGJERC00050G | -5°C to +70°C | Commercial | 1537.40 | 195.0 | 50 | 40km |
| TPD1XGJERC00049G | -5°C to +70°C | Commercial | 1538.19 | 194.9 | 49 | 40km |
| TPD1XGJERC00048G | -5°C to +70°C | Commercial | 1538.98 | 194.8 | 48 | 40km |
| TPD1XGJERC00047G | -5°C to +70°C | Commercial | 1539.77 | 194.7 | 47 | 40km |
| TPD1XGJERC00046G | -5°C to +70°C | Commercial | 1540.56 | 194.6 | 46 | 40km |
| TPD1XGJERC00045G | -5°C to +70°C | Commercial | 1541.35 | 194.5 | 45 | 40km |

| Model Name | Operating Temperature | | Center Wavelength (nm) | ITU Frequency (THz) | Wavelength Reference | Distance |
|------------------|-----------------------|------------|------------------------|---------------------|----------------------|----------|
| | | | | | | |
| TPD1XGJERC00044G | - 5°C to +70°C | Commercial | 1542.14 | 194.4 | 44 | 40km |
| TPD1XGJERC00043G | - 5°C to +70°C | Commercial | 1542.94 | 194.3 | 43 | 40km |
| TPD1XGJERC00042G | - 5°C to +70°C | Commercial | 1543.73 | 194.2 | 42 | 40km |
| TPD1XGJERC00041G | - 5°C to +70°C | Commercial | 1544.53 | 194.1 | 41 | 40km |
| TPD1XGJERC00040G | - 5°C to +70°C | Commercial | 1545.32 | 194.0 | 40 | 40km |
| TPD1XGJERC00039G | - 5°C to +70°C | Commercial | 1546.12 | 193.9 | 39 | 40km |
| TPD1XGJERC00038G | - 5°C to +70°C | Commercial | 1546.92 | 193.8 | 38 | 40km |
| TPD1XGJERC00037G | - 5°C to +70°C | Commercial | 1547.72 | 193.7 | 37 | 40km |
| TPD1XGJERC00036G | - 5°C to +70°C | Commercial | 1548.51 | 193.6 | 36 | 40km |
| TPD1XGJERC00035G | - 5°C to +70°C | Commercial | 1549.32 | 193.5 | 35 | 40km |
| TPD1XGJERC00034G | - 5°C to +70°C | Commercial | 1550.12 | 193.4 | 34 | 40km |
| TPD1XGJERC00033G | - 5°C to +70°C | Commercial | 1550.92 | 193.3 | 33 | 40km |
| TPD1XGJERC00032G | - 5°C to +70°C | Commercial | 1551.72 | 193.2 | 32 | 40km |
| TPD1XGJERC00031G | - 5°C to +70°C | Commercial | 1552.52 | 193.1 | 31 | 40km |
| TPD1XGJERC00030G | - 5°C to +70°C | Commercial | 1553.33 | 193.0 | 30 | 40km |
| TPD1XGJERC00029G | - 5°C to +70°C | Commercial | 1554.13 | 192.9 | 29 | 40km |
| TPD1XGJERC00028G | - 5°C to +70°C | Commercial | 1554.94 | 192.8 | 28 | 40km |
| TPD1XGJERC00027G | - 5°C to +70°C | Commercial | 1555.75 | 192.7 | 27 | 40km |
| TPD1XGJERC00026G | - 5°C to +70°C | Commercial | 1556.55 | 192.6 | 26 | 40km |
| TPD1XGJERC00025G | - 5°C to +70°C | Commercial | 1557.36 | 192.5 | 25 | 40km |
| TPD1XGJERC00024G | - 5°C to +70°C | Commercial | 1558.17 | 192.4 | 24 | 40km |
| TPD1XGJERC00023G | - 5°C to +70°C | Commercial | 1558.98 | 192.3 | 23 | 40km |
| TPD1XGJERC00022G | - 5°C to +70°C | Commercial | 1559.79 | 192.2 | 22 | 40km |
| TPD1XGJERC00021G | - 5°C to +70°C | Commercial | 1560.61 | 192.1 | 21 | 40km |
| TPD1XGJERC00020G | - 5°C to +70°C | Commercial | 1561.42 | 192.0 | 20 | 40km |
| TPD1XGJERC00019G | - 5°C to +70°C | Commercial | 1562.23 | 191.9 | 19 | 40km |
| TPD1XGJERC00018G | - 5°C to +70°C | Commercial | 1563.05 | 191.8 | 18 | 40km |
| TPD1XGJERC00017G | - 5°C to +70°C | Commercial | 1563.86 | 191.7 | 17 | 40km |

| Model Name | Operating Temperature | | Center Wavelength (nm) | ITU Frequency (THz) | Wavelength Reference | Distance |
|------------------|-----------------------|----------|------------------------|---------------------|----------------------|----------|
| | | | | | | |
| TPD1XGJERE00061G | - 5°C to +85°C | Extended | 1528.77 | 196.1 | 61 | 40km |
| TPD1XGJERE00060G | - 5°C to +85°C | Extended | 1529.55 | 196.0 | 60 | 40km |
| TPD1XGJERE00059G | - 5°C to +85°C | Extended | 1530.33 | 195.9 | 59 | 40km |
| TPD1XGJERE00058G | - 5°C to +85°C | Extended | 1531.12 | 195.8 | 58 | 40km |
| TPD1XGJERE00057G | - 5°C to +85°C | Extended | 1531.90 | 195.7 | 57 | 40km |
| TPD1XGJERE00056G | - 5°C to +85°C | Extended | 1532.68 | 195.6 | 56 | 40km |
| TPD1XGJERE00055G | - 5°C to +85°C | Extended | 1533.47 | 195.5 | 55 | 40km |
| TPD1XGJERE00054G | - 5°C to +85°C | Extended | 1534.25 | 195.4 | 54 | 40km |
| TPD1XGJERE00053G | - 5°C to +85°C | Extended | 1535.04 | 195.3 | 53 | 40km |
| TPD1XGJERE00052G | - 5°C to +85°C | Extended | 1535.82 | 195.2 | 52 | 40km |
| TPD1XGJERE00051G | - 5°C to +85°C | Extended | 1536.61 | 195.1 | 51 | 40km |
| TPD1XGJERE00050G | - 5°C to +85°C | Extended | 1537.40 | 195.0 | 50 | 40km |

| Model Name | Operating Temperature | | Center Wavelength (nm) | ITU Frequency (THz) | Wavelength Reference | Distance |
|------------------|-----------------------|----------|------------------------|---------------------|----------------------|----------|
| | | | | | | |
| TPD1XGJERE00049G | -5°C to +85°C | Extended | 1538.19 | 194.9 | 49 | 40km |
| TPD1XGJERE00048G | -5°C to +85°C | Extended | 1538.98 | 194.8 | 48 | 40km |
| TPD1XGJERE00047G | -5°C to +85°C | Extended | 1539.77 | 194.7 | 47 | 40km |
| TPD1XGJERE00046G | -5°C to +85°C | Extended | 1540.56 | 194.6 | 46 | 40km |
| TPD1XGJERE00045G | -5°C to +85°C | Extended | 1541.35 | 194.5 | 45 | 40km |
| TPD1XGJERE00044G | -5°C to +85°C | Extended | 1542.14 | 194.4 | 44 | 40km |
| TPD1XGJERE00043G | -5°C to +85°C | Extended | 1542.94 | 194.3 | 43 | 40km |
| TPD1XGJERE00042G | -5°C to +85°C | Extended | 1543.73 | 194.2 | 42 | 40km |
| TPD1XGJERE00041G | -5°C to +85°C | Extended | 1544.53 | 194.1 | 41 | 40km |
| TPD1XGJERE00040G | -5°C to +85°C | Extended | 1545.32 | 194.0 | 40 | 40km |
| TPD1XGJERE00039G | -5°C to +85°C | Extended | 1546.12 | 193.9 | 39 | 40km |
| TPD1XGJERE00038G | -5°C to +85°C | Extended | 1546.92 | 193.8 | 38 | 40km |
| TPD1XGJERE00037G | -5°C to +85°C | Extended | 1547.72 | 193.7 | 37 | 40km |
| TPD1XGJERE00036G | -5°C to +85°C | Extended | 1548.51 | 193.6 | 36 | 40km |
| TPD1XGJERE00035G | -5°C to +85°C | Extended | 1549.32 | 193.5 | 35 | 40km |
| TPD1XGJERE00034G | -5°C to +85°C | Extended | 1550.12 | 193.4 | 34 | 40km |
| TPD1XGJERE00033G | -5°C to +85°C | Extended | 1550.92 | 193.3 | 33 | 40km |
| TPD1XGJERE00032G | -5°C to +85°C | Extended | 1551.72 | 193.2 | 32 | 40km |
| TPD1XGJERE00031G | -5°C to +85°C | Extended | 1552.52 | 193.1 | 31 | 40km |
| TPD1XGJERE00030G | -5°C to +85°C | Extended | 1553.33 | 193.0 | 30 | 40km |
| TPD1XGJERE00029G | -5°C to +85°C | Extended | 1554.13 | 192.9 | 29 | 40km |
| TPD1XGJERE00028G | -5°C to +85°C | Extended | 1554.94 | 192.8 | 28 | 40km |
| TPD1XGJERE00027G | -5°C to +85°C | Extended | 1555.75 | 192.7 | 27 | 40km |
| TPD1XGJERE00026G | -5°C to +85°C | Extended | 1556.55 | 192.6 | 26 | 40km |
| TPD1XGJERE00025G | -5°C to +85°C | Extended | 1557.36 | 192.5 | 25 | 40km |
| TPD1XGJERE00024G | -5°C to +85°C | Extended | 1558.17 | 192.4 | 24 | 40km |
| TPD1XGJERE00023G | -5°C to +85°C | Extended | 1558.98 | 192.3 | 23 | 40km |
| TPD1XGJERE00022G | -5°C to +85°C | Extended | 1559.79 | 192.2 | 22 | 40km |
| TPD1XGJERE00021G | -5°C to +85°C | Extended | 1560.61 | 192.1 | 21 | 40km |
| TPD1XGJERE00020G | -5°C to +85°C | Extended | 1561.42 | 192.0 | 20 | 40km |
| TPD1XGJERE00019G | -5°C to +85°C | Extended | 1562.23 | 191.9 | 19 | 40km |
| TPD1XGJERE00018G | -5°C to +85°C | Extended | 1563.05 | 191.8 | 18 | 40km |
| TPD1XGJERE00017G | -5°C to +85°C | Extended | 1563.86 | 191.7 | 17 | 40km |

| Model Name | Operating Temperature | | Center Wavelength (nm) | ITU Frequency (THz) | Wavelength Reference | Distance |
|------------------|-----------------------|------------|------------------------|---------------------|----------------------|----------|
| | | | | | | |
| TPD1XGJERI00061G | -40°C to +85°C | Industrial | 1528.77 | 196.1 | 61 | 40km |
| TPD1XGJERI00060G | -40°C to +85°C | Industrial | 1529.55 | 196.0 | 60 | 40km |
| TPD1XGJERI00059G | -40°C to +85°C | Industrial | 1530.33 | 195.9 | 59 | 40km |
| TPD1XGJERI00058G | -40°C to +85°C | Industrial | 1531.12 | 195.8 | 58 | 40km |
| TPD1XGJERI00057G | -40°C to +85°C | Industrial | 1531.90 | 195.7 | 57 | 40km |
| TPD1XGJERI00056G | -40°C to +85°C | Industrial | 1532.68 | 195.6 | 56 | 40km |
| TPD1XGJERI00055G | -40°C to +85°C | Industrial | 1533.47 | 195.5 | 55 | 40km |

| Model Name | Operating Temperature | | Center Wavelength (nm) | ITU Frequency (THz) | Wavelength Reference | Distance |
|-----------------|-----------------------|------------|------------------------|---------------------|----------------------|----------|
| TPD1XGJER00054G | -40°C to +85°C | Industrial | 1534.25 | 195.4 | 54 | 40km |
| TPD1XGJER00053G | -40°C to +85°C | Industrial | 1535.04 | 195.3 | 53 | 40km |
| TPD1XGJER00052G | -40°C to +85°C | Industrial | 1535.82 | 195.2 | 52 | 40km |
| TPD1XGJER00051G | -40°C to +85°C | Industrial | 1536.61 | 195.1 | 51 | 40km |
| TPD1XGJER00050G | -40°C to +85°C | Industrial | 1537.40 | 195.0 | 50 | 40km |
| TPD1XGJER00049G | -40°C to +85°C | Industrial | 1538.19 | 194.9 | 49 | 40km |
| TPD1XGJER00048G | -40°C to +85°C | Industrial | 1538.98 | 194.8 | 48 | 40km |
| TPD1XGJER00047G | -40°C to +85°C | Industrial | 1539.77 | 194.7 | 47 | 40km |
| TPD1XGJER00046G | -40°C to +85°C | Industrial | 1540.56 | 194.6 | 46 | 40km |
| TPD1XGJER00045G | -40°C to +85°C | Industrial | 1541.35 | 194.5 | 45 | 40km |
| TPD1XGJER00044G | -40°C to +85°C | Industrial | 1542.14 | 194.4 | 44 | 40km |
| TPD1XGJER00043G | -40°C to +85°C | Industrial | 1542.94 | 194.3 | 43 | 40km |
| TPD1XGJER00042G | -40°C to +85°C | Industrial | 1543.73 | 194.2 | 42 | 40km |
| TPD1XGJER00041G | -40°C to +85°C | Industrial | 1544.53 | 194.1 | 41 | 40km |
| TPD1XGJER00040G | -40°C to +85°C | Industrial | 1545.32 | 194.0 | 40 | 40km |
| TPD1XGJER00039G | -40°C to +85°C | Industrial | 1546.12 | 193.9 | 39 | 40km |
| TPD1XGJER00038G | -40°C to +85°C | Industrial | 1546.92 | 193.8 | 38 | 40km |
| TPD1XGJER00037G | -40°C to +85°C | Industrial | 1547.72 | 193.7 | 37 | 40km |
| TPD1XGJER00036G | -40°C to +85°C | Industrial | 1548.51 | 193.6 | 36 | 40km |
| TPD1XGJER00035G | -40°C to +85°C | Industrial | 1549.32 | 193.5 | 35 | 40km |
| TPD1XGJER00034G | -40°C to +85°C | Industrial | 1550.12 | 193.4 | 34 | 40km |
| TPD1XGJER00033G | -40°C to +85°C | Industrial | 1550.92 | 193.3 | 33 | 40km |
| TPD1XGJER00032G | -40°C to +85°C | Industrial | 1551.72 | 193.2 | 32 | 40km |
| TPD1XGJER00031G | -40°C to +85°C | Industrial | 1552.52 | 193.1 | 31 | 40km |
| TPD1XGJER00030G | -40°C to +85°C | Industrial | 1553.33 | 193.0 | 30 | 40km |
| TPD1XGJER00029G | -40°C to +85°C | Industrial | 1554.13 | 192.9 | 29 | 40km |
| TPD1XGJER00028G | -40°C to +85°C | Industrial | 1554.94 | 192.8 | 28 | 40km |
| TPD1XGJER00027G | -40°C to +85°C | Industrial | 1555.75 | 192.7 | 27 | 40km |
| TPD1XGJER00026G | -40°C to +85°C | Industrial | 1556.55 | 192.6 | 26 | 40km |
| TPD1XGJER00025G | -40°C to +85°C | Industrial | 1557.36 | 192.5 | 25 | 40km |
| TPD1XGJER00024G | -40°C to +85°C | Industrial | 1558.17 | 192.4 | 24 | 40km |
| TPD1XGJER00023G | -40°C to +85°C | Industrial | 1558.98 | 192.3 | 23 | 40km |
| TPD1XGJER00022G | -40°C to +85°C | Industrial | 1559.79 | 192.2 | 22 | 40km |
| TPD1XGJER00021G | -40°C to +85°C | Industrial | 1560.61 | 192.1 | 21 | 40km |
| TPD1XGJER00020G | -40°C to +85°C | Industrial | 1561.42 | 192.0 | 20 | 40km |
| TPD1XGJER00019G | -40°C to +85°C | Industrial | 1562.23 | 191.9 | 19 | 40km |
| TPD1XGJER00018G | -40°C to +85°C | Industrial | 1563.05 | 191.8 | 18 | 40km |
| TPD1XGJER00017G | -40°C to +85°C | Industrial | 1563.86 | 191.7 | 17 | 40km |

Oplink Communications, Inc. reserves the right to make changes in equipment design or specifications without notice. Information supplied by Oplink Communications, Inc. is believed to be accurate and reliable. However, no responsibility is assumed by Oplink Communications, Inc. for its use nor for any infringements of third parties, which may result from its use. No license is granted by implication or otherwise under any patent right of Oplink Communications, Inc.

© 2014, Oplink Communications, Inc.