

Automotive Grade AUIR2085S

HIGH SPEED, 100V, SELF OSCILLATING 50%
DUTY CYCLE, HALF-BRIDGE DRIVER

Features

- Simple primary side control solution to enable half-bridge DC-Bus Converters for 48V distributed systems with reduced component count and board space
- Integrated 50% duty cycle oscillator & half-bridge driver IC in a single SO-8 package
- Programmable switching frequency with up to 500kHz max per channel
- +/- 1A drive current capability optimized for low charge MOSFETs
- Adjustable dead-time 50ns – 200ns
- Floating channel designed for bootstrap operation up to +100Vdc
- High and low side pulse width matching to +/- 25ns
- Adjustable overcurrent protection
- Undervoltage lockout and internal soft start
- Leadfree, RoHS compliant
- Automotive qualified*

Typical Applications

- DC-DC Converters
- HEV Auxiliary Converter
- Battery Management Converters

Product Summary

Topology	Half-Bridge
V_{OFFSET}	$\leq 100 \text{ V}$
$I_{\text{o+}} \& I_{\text{o-}}$ (typical)	1.0A & 1.0A
f_{OSC} (max)	500kHz
Deadtime	50ns – 200ns
HO/LO Pulse Matching	+/- 25ns

Package Options



8 - Lead SOIC
AUIR2085S

Typical Connection Diagram

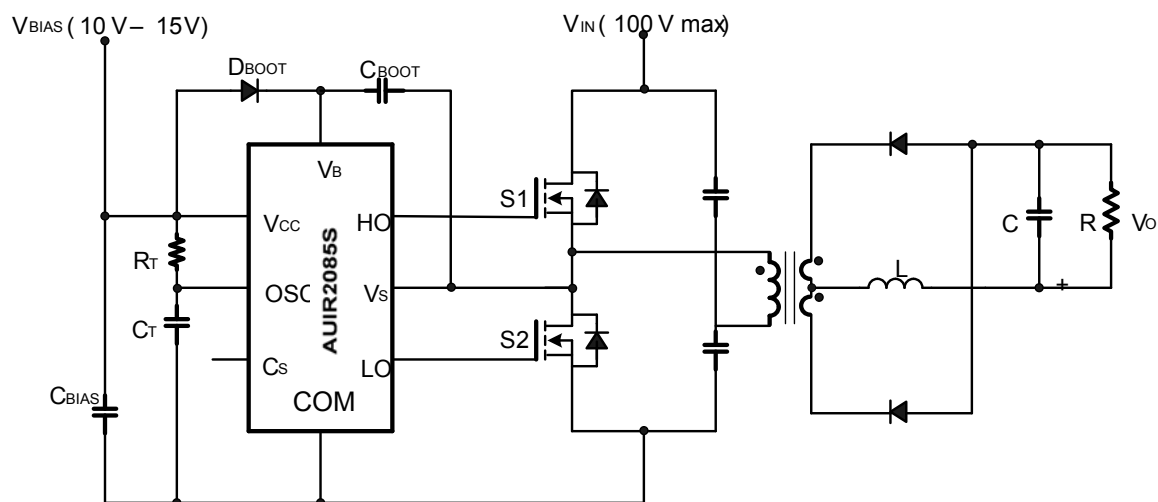

Table of Contents	Page
Typical Connection Diagram	1
Description/Feature Comparison	3
Qualification Information	4
Absolute Maximum Ratings	5
Recommended Operating Conditions	5
Dynamic Electrical Characteristics	6
Static Electrical Characteristics	6
Functional Block Diagram	7
Input/Output Pin Equivalent Circuit Diagram	9
Lead Definitions	10
Lead Assignments	10
Package Details	12
Tape and Reel Details	13
Part Marking Information	14
Ordering Information	15

Description

The AUIR2085S is a self oscillating half-bridge driver IC with 50% duty cycle ideally suited for 36V – 75V half-bridge DC-bus converters.

This product is also suitable for push-pull converters without restriction on input voltage.

Each channel frequency is equal to f_{OSC} , which can be set by selecting R_T & C_T , as for Fig. 1. Dead-time can be controlled through proper selection of C_T and can range from 50ns to 200ns, as for Fig.2.

Internal soft-start increases the pulse width during power up and maintains pulse width matching for the high and low outputs throughout the start up cycle.

Typically soft-start duty cycle varies beginning from 5-10% ramping up to about 50% over 1000 cycles.

The AUIR2085S initiates a soft start at power up and after every overcurrent condition. Undervoltage lockout prevents operation if V_{CC} is less than 7.5V.

Qualification Information[†]

Qualification Level		Automotive (per AEC-Q100)	
		Comments: This family of ICs has passed an Automotive qualification. IR's Industrial and Consumer qualification level is granted by extension of the higher Automotive level.	
Moisture Sensitivity Level		SOIC8N	MSL3 ^{††} 260°C (per IPC/JEDEC J-STD-020)
ESD	Machine Model	Class M2 (+/-200V) (per AEC-Q100-003)	
	Human Body Model	Class H1B (+/-1750V) (per AEC-Q100-002)	
	Charged Device Model	Class C4 (+/-1000V) (per AEC-Q100-011)	
IC Latch-Up Test		Class II, Level B (per AEC-Q100-004)	
RoHS Compliant		Yes	

† Qualification standards can be found at International Rectifier's web site <http://www.irf.com/>

†† Higher MSL ratings may be available for the specific package types listed here. Please contact your International Rectifier sales representative for further information.

Absolute Maximum Ratings

Absolute Maximum Ratings indicate sustained limits beyond which damage to the device may occur. All voltage parameters are absolute voltages referenced to COM. The thermal resistance and power dissipation ratings are measured under board mounted and still air conditions.

Symbol	Definition	Min.	Max.	Units
V_B	High side floating supply voltage	-0.3	150	V
V_{CC}	Low side supply voltage	—	25	
V_S	High side floating supply offset voltage	$V_B - 25$	$V_B + 0.3$	
V_{HO}	High side floating output voltage	$V_B - 0.3$	$V_B + 0.3$	
V_{LO}	Low side output voltage	-0.3	$V_{CC} + 0.3$	
OSC	OSC pin voltage	-0.3	$V_{CC} + 0.3$	
V_{CS}	C_S pin voltage	-0.3	$V_{CC} + 0.3$	
dVs/dt	Allowable offset voltage slew rate	—	50	V/ns
P_D	Package power dissipation @ $T_A \leq 25^\circ\text{C}$	—	0.625	W
R_{thJA}	Thermal resistance, junction to ambient	—	200	$^\circ\text{C}/\text{W}$
T_J	Junction temperature	—	150	$^\circ\text{C}$
T_S	Storage temperature	-55	150	
T_L	Lead temperature (soldering, 10 seconds)	—	300	

Recommended Operating Conditions

For proper operation the device should be used within the recommended conditions.

Symbol	Definition	Min.	Max.	Units
V_B	High side floating supply voltage	$V_S + 10$	$V_S + 15$	V
V_S	Steady state high side floating supply offset voltage	-5 (†)	100	
V_{CC}	Supply voltage	10	15	
I_{CC}	Supply current	—	5	mA
R_T	Timing resistor	10	100	k Ω
C_T	Timing capacitor	47	470	pF
f_{osc}	Operating frequency (per channel)	—	500	kHz
T_A	Ambient temperature	-40	125	$^\circ\text{C}$

† Care should be taken to avoid output switching conditions where the V_S node flies inductively below ground by more than 5V.

Dynamic Electrical Characteristics

$V_{CC} = V_{BS} = 12V$, $C_{LOAD} = 1000pF$, and $T_A = 25^{\circ}C$ unless otherwise specified.

Symbol	Definition	Min	Typ	Max	Units	Test Conditions
t_r	Turn-on rise time	—	40	60	ns	$V_S = 0V$
t_f	Turn-off fall time	—	20	30		
f_{OSC}	Per channel output frequency	500	—	—	ns	$C_T = 100pF$, $R_T = 10k\Omega$
t_{DT}	HO/LO output dead time	50	—	—		
t_{DCS}	Overcurrent shut down delay	—	200	—		
PM	HO/LO pulse width mismatch	-25	—	25		

Static Electrical Characteristics

$V_{CC} = V_{BS} = 12V$, $C_{LOAD} = 1000pF$, and $T_A = 25^{\circ}C$ unless otherwise specified.

Symbol	Definition	Min	Typ	Max	Units	Test Conditions
V_{OH}	High level output voltage, V_{CC} or $V_{BS} - V_O$	—	—	1.5	V	
V_{OL}	Low level output voltage	—	—	0.1		
I_{leak}	Offset supply leakage current	—	—	50	μA	
I_{QBS}	Quiescent V_{BS} supply current	—	—	150		
I_{QCC}	Quiescent V_{CC} supply current	—	—	1.5	mA	
V_{CS+}	Overcurrent shutdown threshold	250	300	350	mV	
V_{CS-}	Overcurrent shutdown threshold	150	200	250	mV	
V_{CCUV+}	Undervoltage positive going threshold	6.8	7.3	7.8	V	
V_{CCUV-}	Undervoltage negative going threshold	6.3	6.8	7.3		
V_{BSUV+}	High side undervoltage positive going threshold	6.8	7.3	7.8		
V_{BSUV-}	High side undervoltage negative going threshold	6.3	6.8	7.3		
I_{O+}	Output high short circuit current	—	1.0	—	A	
I_{O-}	Output low short circuit current	—	1.0	—		

Functional Block Diagram

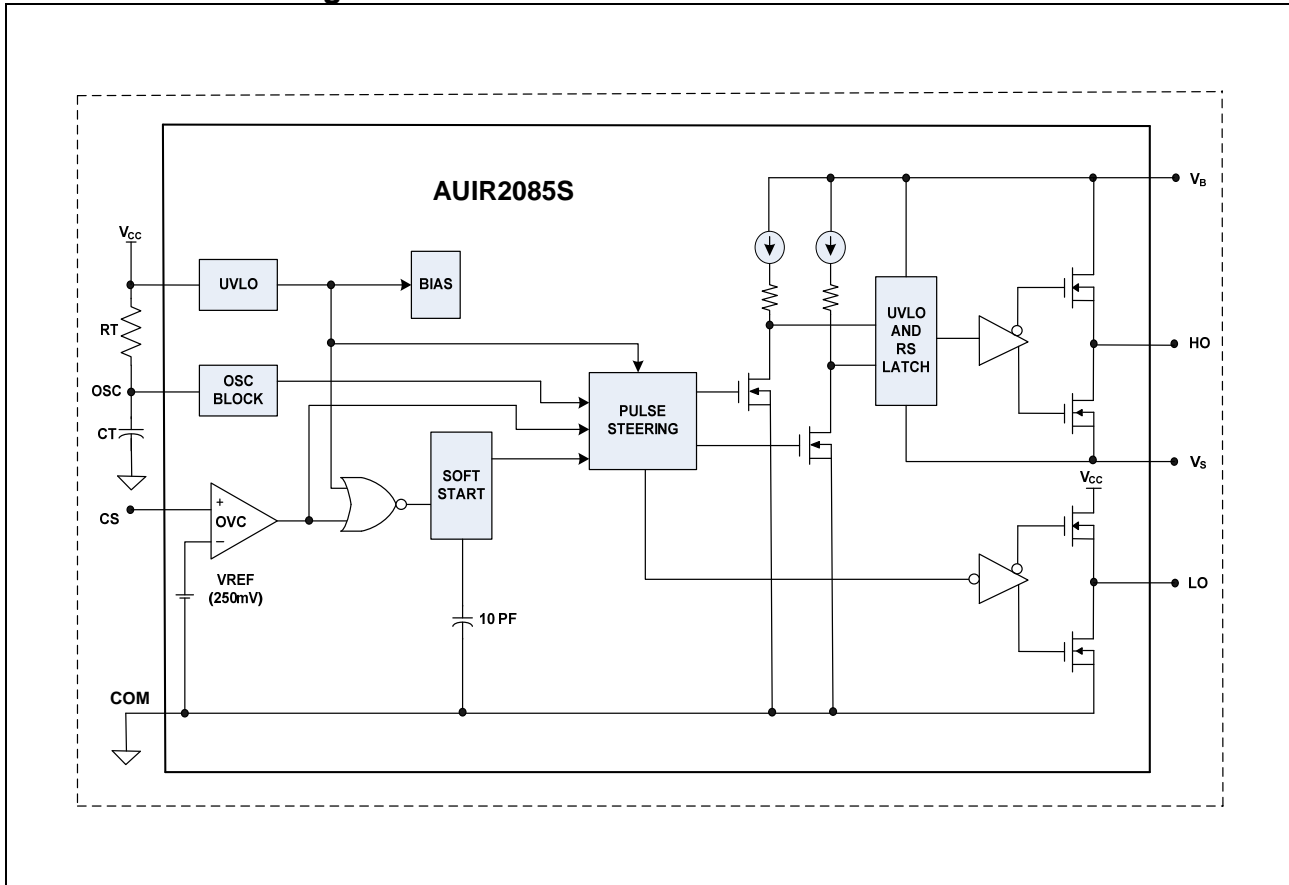

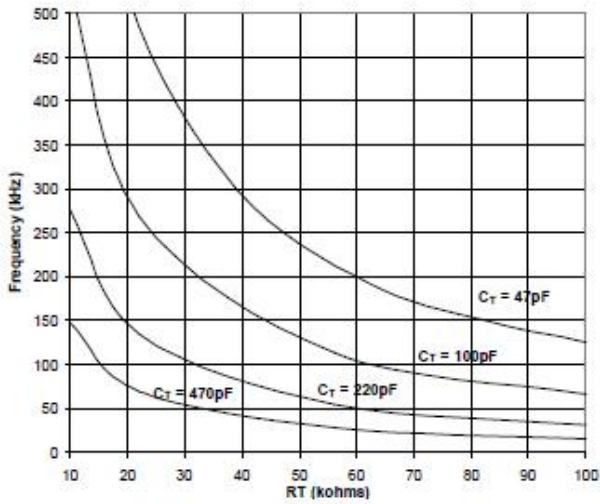

Fig. 1 Typical Output Frequency (-25°C to 125°C)

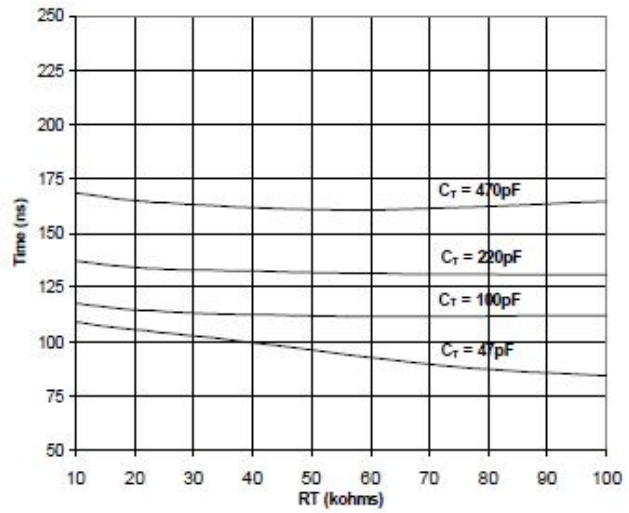

Fig. 2 Typical Dead Time (@25°C)

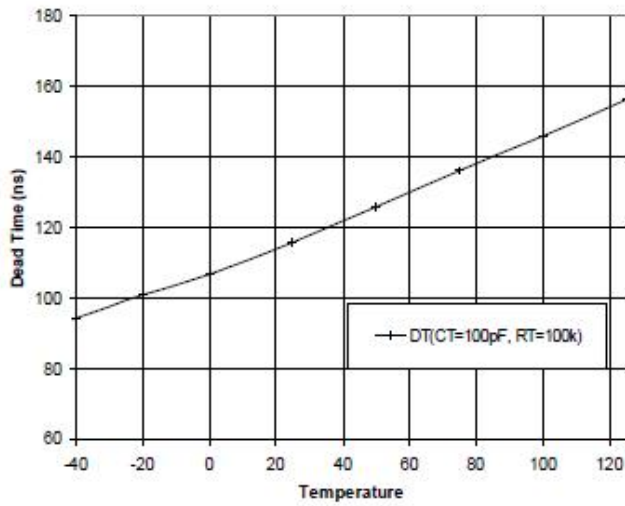
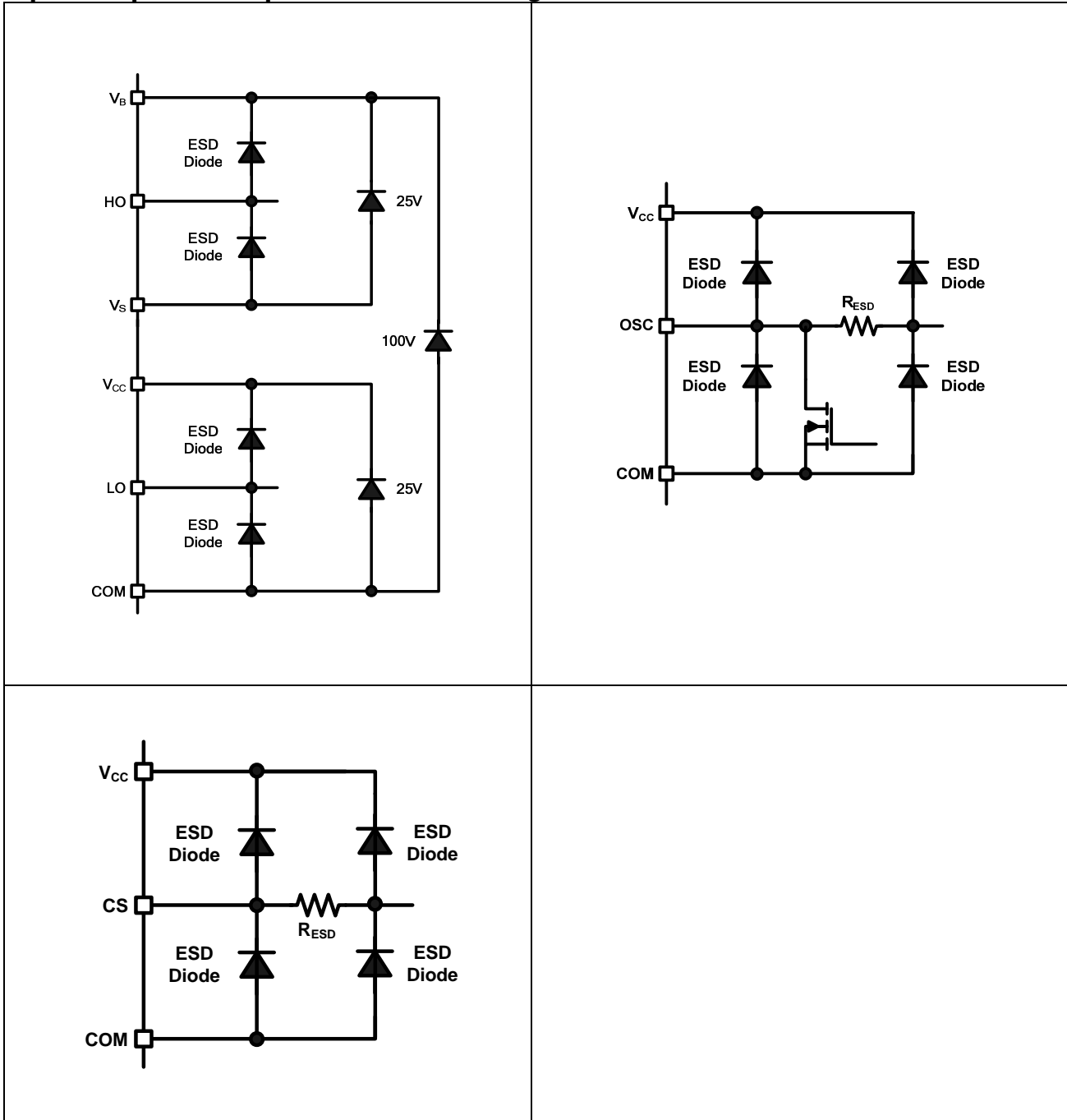

Fig. 3 Typical Dead Time vs Temperature

Input/Output Pin Equivalent Circuit Diagrams



Lead Definitions

PIN	Symbol	Description
1	CS	Current sense input
2	OSC	Oscillator pin
3	COM	Logic supply return
4	LO	Low side output
5	V _{CC}	Logic supply
6	V _S	Floating supply return
7	HO	High side output
8	V _B	High side floating supply

Lead Assignments

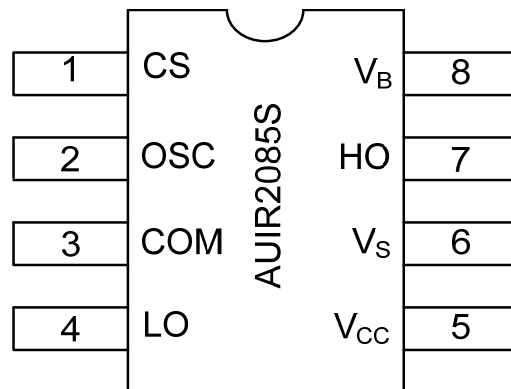

Pin Descriptions

Cs: The input pin to the overcurrent comparator. Exceeding the overcurrent threshold value specified in “Static Electrical Parameters” Section will terminate output pulses and start a new soft start cycle as soon as the voltage on the pin reduce below the threshold value.

OSC: The oscillator-programming pin. Only two components are required to program the internal oscillator frequency: a resistor connected between the V_{CC} pin and the OSC pin, and a capacitor connected from the OSC to COM. The expected oscillator frequency is shown in Figure 1.

The recommended range of timing resistors R_T is between 10k Ω and 100k Ω and range of timing capacitor C_T is between 47pF and 470pF. Timing resistors values less than 10k Ω should be avoided. The value of the timing capacitor determines the amount of dead time between the two output drivers: lower the C_T , shorter the dead time and vice versa. It is not recommended to use a timing capacitor below 47pF, for best performance keep the timing components physically as close as possible to the AUIR2085S. Separated ground and V_{CC} traces to the timing components are encouraged.

COM: Signal ground and power ground for all functions. Due to high current and high frequency operation, a low impedance circuit board ground plane is highly recommended.

HO, LO: High side and low side gate drive pins. The high and low side drivers can directly drive the gate of a power MOSFET. The drivers are capable of 1A peak source and sink currents. It is recommended that the high and low drive pins be very close to the gates of the high side and low side MOSFETs to prevent any delay and distortion of the drive signals.

V_B: The high side power input connection. The high side supply is derived from a bootstrap circuit using a low-leakage Schottky diode and a ceramic capacitor. To prevent noise, the Schottky diode and bypass capacitor should be very close to the AUIR2085S.

V_S: The high side power return connection. V_S should be connected directly to the source terminal of high side MOSFET with a trace as short as possible.

V_{CC}: The IC bias input connection for the device. Although the quiescent V_{CC} current is very low, total supply current will be higher, depending on the gate charge of the MOSFETs connected to the HO and LO pins, and the programmed oscillator frequency, total V_{CC} current is the sum of quiescent V_{CC} current and the average current at HO and LO. Knowing the operating frequency and the MOSFET gate charge (Qg) at selected V_{CC} voltage, the average current (including bootstrap function) can be calculated from:

$$I_{ave} = 2 \times Q_g \times f_{osc}$$

To prevent noise problem, a bypass ceramic capacitor connected to V_{CC} and COM should be placed as close as possible to the AUIR2085S.

AUIR2085S has an under voltage lookout feature for the IC bias supply, V_{CC} . The minimum voltage required on V_{CC} to make sure that IC will work within specifications must be higher than 8.5V (10V minimum V_{CC} is recommended to prevent asymmetrical gates signal on HO and LO pins that are expected when V_{CC} is between 7.5V and 8.5V).

Package Details:

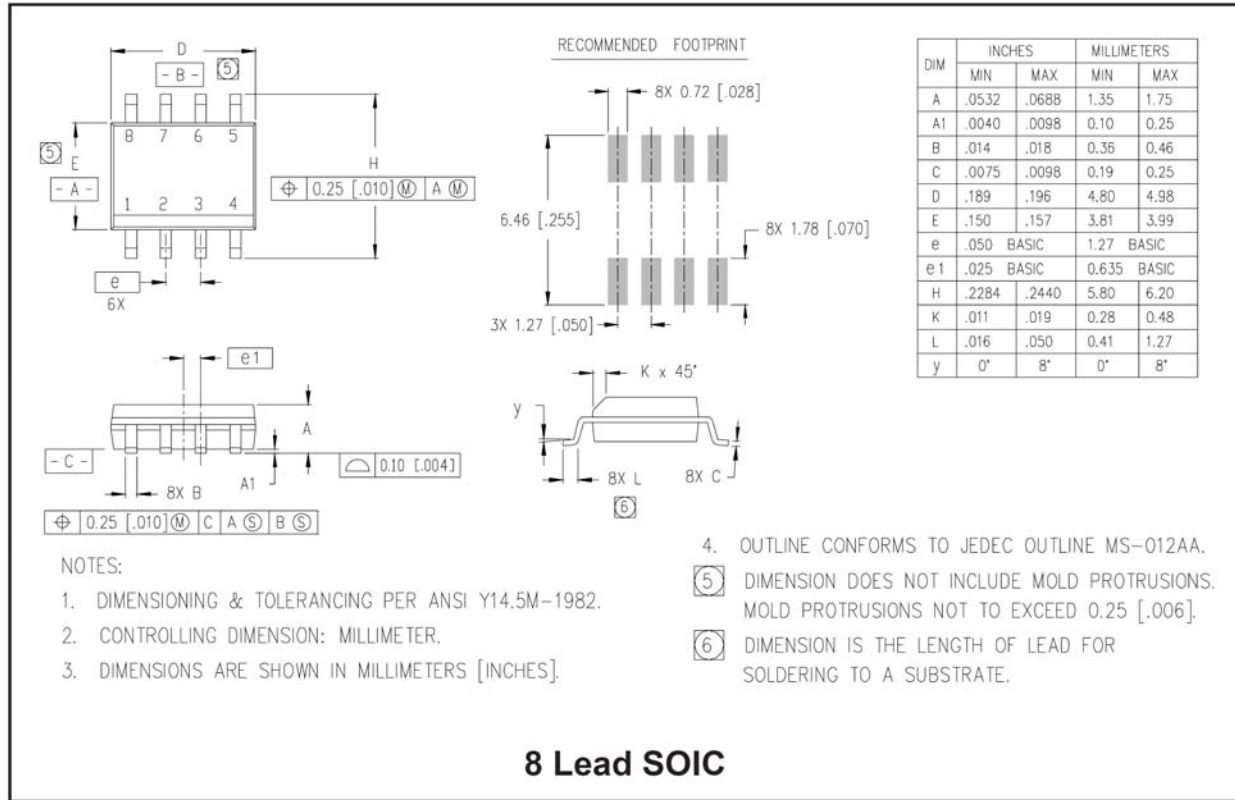

Tape and Reel Details:

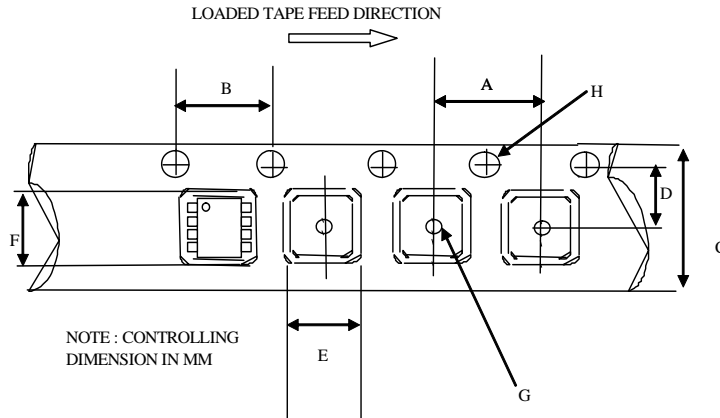

CARRIER TAPE DIMENSION FOR 8SOICN

Code	Metric		Imperial	
	Min	Max	Min	Max
A	7.90	8.10	0.311	0.318
B	3.90	4.10	0.153	0.161
C	11.70	12.30	0.46	0.484
D	5.45	5.55	0.214	0.218
E	6.30	6.50	0.248	0.255
F	5.10	5.30	0.200	0.208
G	1.50	n/a	0.059	n/a
H	1.50	1.60	0.059	0.062

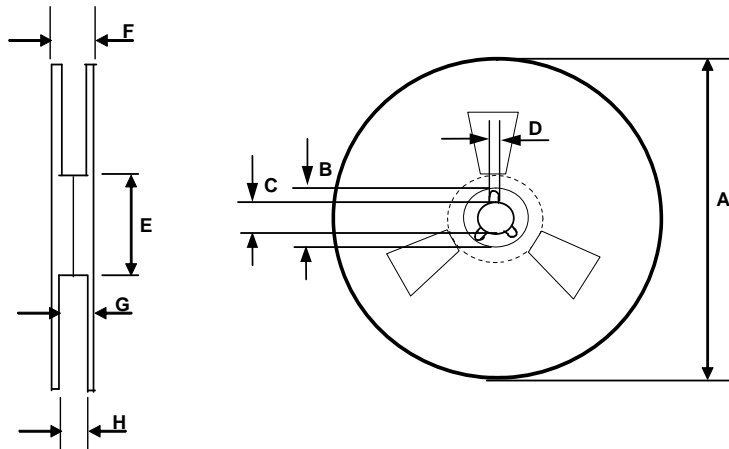

REEL DIMENSIONS FOR 8SOICN

Code	Metric		Imperial	
	Min	Max	Min	Max
A	329.60	330.25	12.976	13.001
B	20.95	21.45	0.824	0.844
C	12.80	13.20	0.503	0.519
D	1.95	2.45	0.767	0.096
E	98.00	102.00	3.858	4.015
F	n/a	18.40	n/a	0.724
G	14.50	17.10	0.570	0.673
H	12.40	14.40	0.488	0.566

Part Marking Information

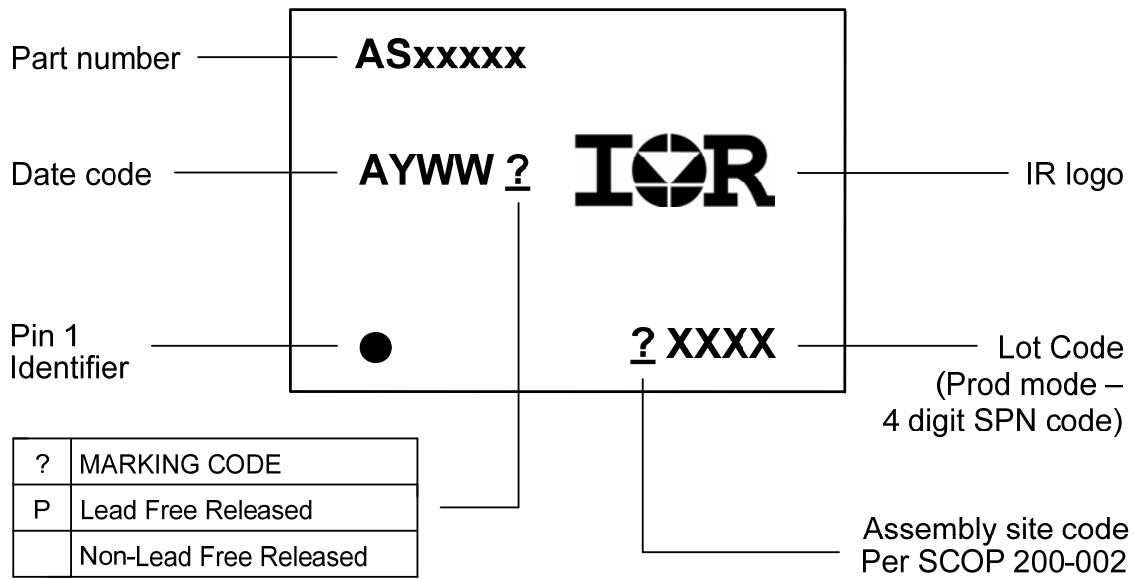

Ordering Information

Base Part Number	Package Type	Standard Pack		Complete Part Number
		Form	Quantity	
AUIR2085S	SOIC8	Tube/Bulk	95	AUIR2085S
		Tape and Reel	2500	AUIR2085STR

IMPORTANT NOTICE

Unless specifically designated for the automotive market, International Rectifier Corporation and its subsidiaries (IR) reserve the right to make corrections, modifications, enhancements, improvements, and other changes to its products and services at any time and to discontinue any product or services without notice. Part numbers designated with the "AU" prefix follow automotive industry and / or customer specific requirements with regards to product discontinuance and process change notification. All products are sold subject to IR's terms and conditions of sale supplied at the time of order acknowledgment.

IR warrants performance of its hardware products to the specifications applicable at the time of sale in accordance with IR's standard warranty. Testing and other quality control techniques are used to the extent IR deems necessary to support this warranty. Except where mandated by government requirements, testing of all parameters of each product is not necessarily performed.

IR assumes no liability for applications assistance or customer product design. Customers are responsible for their products and applications using IR components. To minimize the risks with customer products and applications, customers should provide adequate design and operating safeguards.

Reproduction of IR information in IR data books or data sheets is permissible only if reproduction is without alteration and is accompanied by all associated warranties, conditions, limitations, and notices. Reproduction of this information with alterations is an unfair and deceptive business practice. IR is not responsible or liable for such altered documentation. Information of third parties may be subject to additional restrictions.

Resale of IR products or serviced with statements different from or beyond the parameters stated by IR for that product or service voids all express and any implied warranties for the associated IR product or service and is an unfair and deceptive business practice. IR is not responsible or liable for any such statements.

IR products are not designed, intended, or authorized for use as components in systems intended for surgical implant into the body, or in other applications intended to support or sustain life, or in any other application in which the failure of the IR product could create a situation where personal injury or death may occur. Should Buyer purchase or use IR products for any such unintended or unauthorized application, Buyer shall indemnify and hold International Rectifier and its officers, employees, subsidiaries, affiliates, and distributors harmless against all claims, costs, damages, and expenses, and reasonable attorney fees arising out of, directly or indirectly, any claim of personal injury or death associated with such unintended or unauthorized use, even if such claim alleges that IR was negligent regarding the design or manufacture of the product.

IR products are neither designed nor intended for use in military/aerospace applications or environments unless the IR products are specifically designated by IR as military-grade or "enhanced plastic." Only products designated by IR as military-grade meet military specifications. Buyers acknowledge and agree that any such use of IR products which IR has not designated as military-grade is solely at the Buyer's risk, and that they are solely responsible for compliance with all legal and regulatory requirements in connection with such use.

IR products are neither designed nor intended for use in automotive applications or environments unless the specific IR products are designated by IR as compliant with ISO/TS 16949 requirements and bear a part number including the designation "AU". Buyers acknowledge and agree that, if they use any non-designated products in automotive applications, IR will not be responsible for any failure to meet such requirements.

For technical support, please contact IR's Technical Assistance Center
<http://www.irf.com/technical-info/>

WORLD HEADQUARTERS:
101 N. Sepulveda Blvd., El Segundo, California 90245
Tel: (310) 252-7105