



Thick Film High Voltage Chip Resistors(for 0805) Halogen-Free

Document No.	TRH-100S014F
Revise Date	2012/07/25
page number	1 / 9

1. Scope :

This specification applies for thick film high voltage chip resistors made by TA-I.

2. Construction:

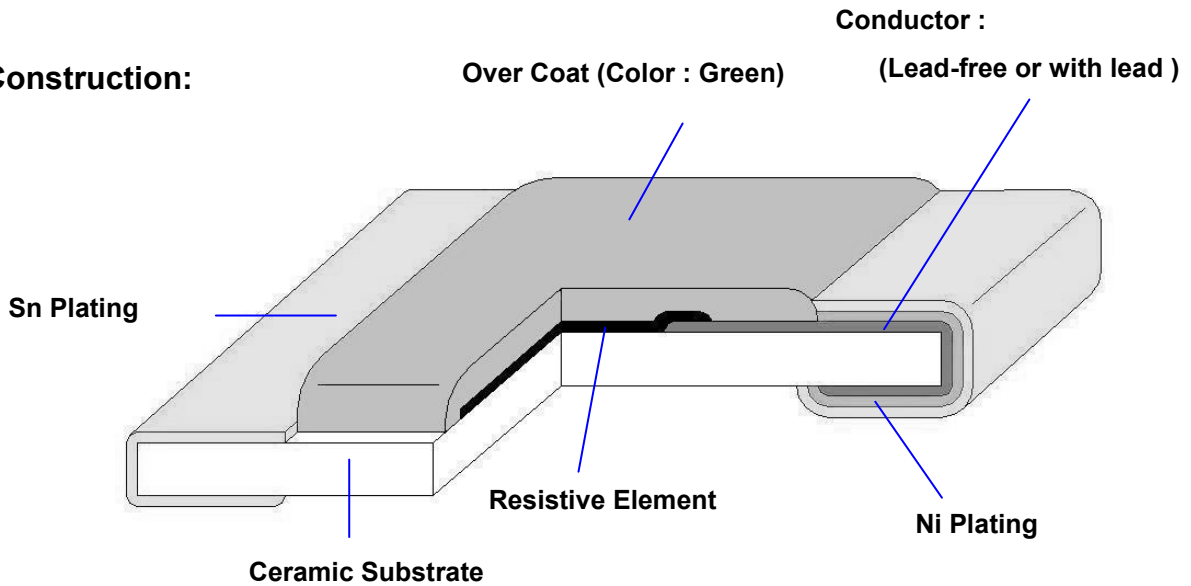

3. Type Designation:

<u>RH</u>	<u>10</u>	<u>F</u>	<u>TN</u>	<u>4993</u>
Product Code	Size	Tolerance	Packaging	Nominal Resistance
RH : High voltage	Power Rating			
10-0805(2012) 1/8W	J- ±5% G- ±2% F- ±1%	TN-Lead Free & Paper Tape	3 digits, e.g.: E-24) 104 = 100kΩ 4 digits, e.g.,: (E-96) 4993 = 499kΩ	



**Thick Film High Voltage
Chip Resistors(for 0805)
Halogen-Free**

Document No.	TRH-100S014F
Revise Date	2012/07/25
page number	2 / 9

4. Dimensions:

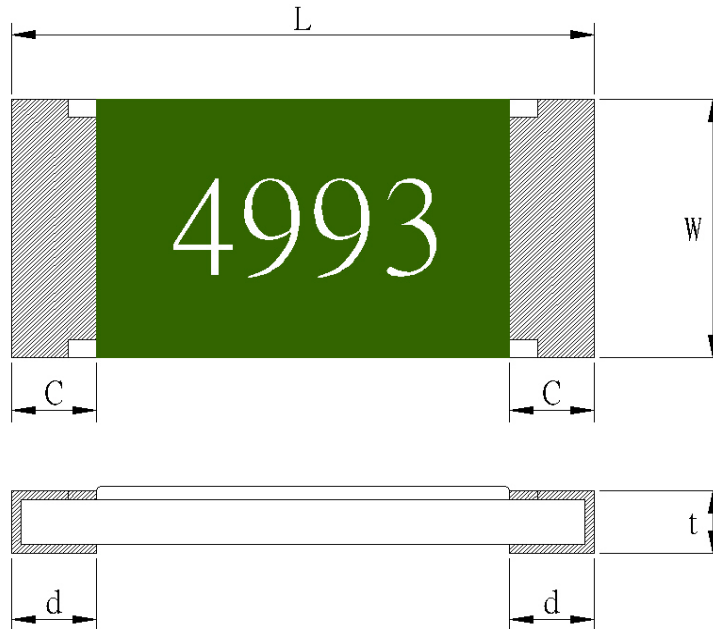

UNIT: mm

Type	L	W	C	d	t
RH10	2.00±0.10	1.25±0.10	0.35±0.20	0.40±0.20	0.50±0.10

5.Ratings & Characteristics :

Characteristics	Rating Voltage	Feature	Measurement Method
		RH10	
Power Ratings (W)	Refer 5.2	1/8W	JIS Code 3A / JIS Code 3D
Resistance Value (Ω)		10kΩ~10MΩ	Refer to JIS C 5201-1- 4.5
T.C.R (ppm/°C)		±200	Refer to JIS C 5201-1- 4.8
Operation Temperature Range (°C)		-55 ~ +155	
Resistance Tolerance (%)		±1, ±2, ±5	JIS C 5201-1- 4.2.5
Maximum Working Voltage (V)		400	
Maximum Overload Voltage (V)		800	

Note : Except for the above standardized products, we also provide the customized products.



**Thick Film High Voltage
Chip Resistors(for 0805)
Halogen-Free**

Document No.	TRH-100S014F
Revise Date	2012/07/25
page number	3 / 9

5.1 Derating Curve :

For resistors operated at ambient temperature over 70°C , power rating shall be derated in accordance with figure 1.

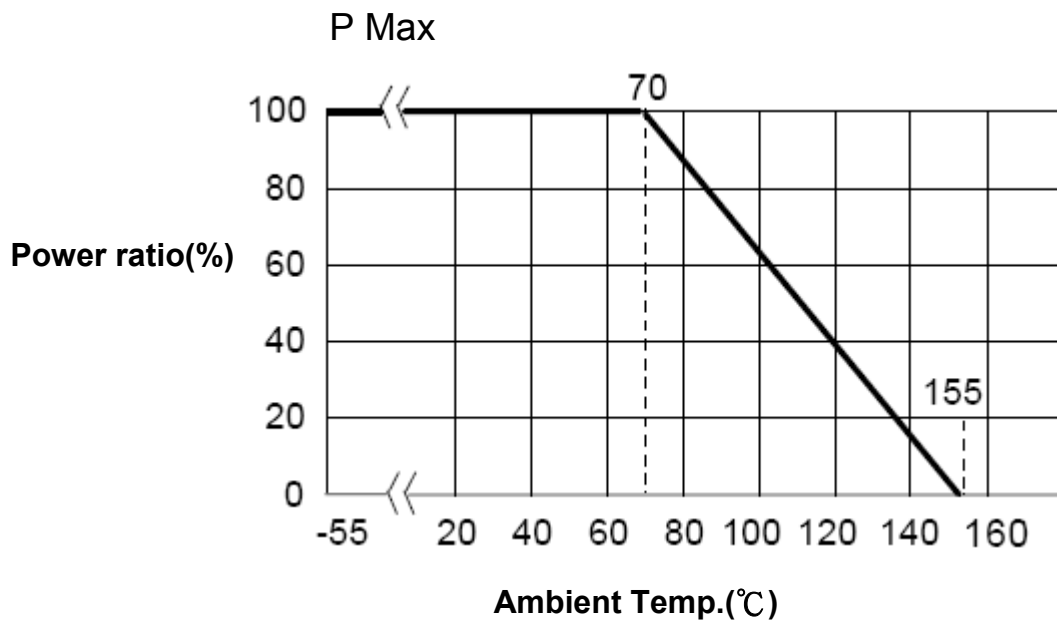

Figure 1

5.2 Rated Voltage:

The rated voltage is calculated by the following formula:

$$E = \sqrt{P * R}$$

E=Rated Voltage(V)
 P=Rated Power(W)
 R=Resistance Value(Ω)

E.G. : What is RH10FTN 3003 the rated voltage ?

$$RH10FTN3003 \quad P=1/8W \quad ; \quad R:3003=300K\Omega=300,000\Omega$$

$$E = \sqrt{1/8(W) * 300000 (\Omega)} = 193.65 V$$

Remark : However , it shall not exceed the maximum rated voltage .



**Thick Film High Voltage
Chip Resistors(for 0805)
Halogen-Free**

Document No.	TRH-100S014F
Revise Date	2012/07/25
page number	4 / 9

6. Reliability Tests:

Test Items	Reference standard	Condition of Test	$\frac{\Delta R}{R}$ Test Limits
Visual examination		Checked by visual examination .	The marking shall be legible , as checked by visual examination
Temperature Coefficient of Resistance	IEC60115-1-4.8 JIS-C5201-1-4.8	-55 ~ +125 °C	Refer to paragraph 5
Dielectric Withstanding Voltage (Voltage Proof)	IEC60115-1-4.7 JIS-C5201-1-4.7	500Va. c., voltage , 1 min .	No abnormalities such as flashover , burning dielectric breakdown shall appear .
Insulation Resistance	IEC60115-1-4.6 JIS-C5201-1-4.6	100V voltage , 1 min .	$\geq 1G$
Solderability	IEC60115-1-4.17 JIS-C5201-1-4.17	245 $\pm 5^{\circ}C$ solder, 2 ± 0.5 sec dwell. Solder : Sn96.5/Ag3/Cu0.5	At least 95% of surface area of electrode shall be covered with new solder.
Short Time Overload	IEC60115-1-4.13 JIS-C5201-1-4.13	2.5 \times rated voltage, 5s	1%: $\pm 1\%+0.05 \Omega$ 5%: $\pm 2\%+0.05 \Omega$
Resistance to Soldering Heat	IEC60115-1-4.18 JIS-C5201-1-4.18	260 $\pm 5^{\circ}C$ solder , 10 ± 1 sec dwell .	$\pm 1\%+0.05 \Omega$
Rapid Change of Temperature	IEC60115-1-4.19 JIS-C5201-1-4.19	-55°C (30 min.) / +125 °C (30 min.) 5 cycles	$\pm 1\%+0.05 \Omega$
Load Life	IEC60115-1-4.25.1 JIS-C5201-1-4.25.1	1000 hours at rated power , 70°C , 1.5hours "ON " , 0.5hour "OFF"	1%: $\pm 1\%+0.1 \Omega$ 5%: $\pm 3\%+0.1 \Omega$
Load Life with Humidity	IEC60115-1-4.24 JIS-C5201-1-4.24	1000 hours at rated voltage , 40 $\pm 2^{\circ}C$, 90~95% RH 1.5hours "ON " , 0.5hour "OFF"	1%: $\pm 1\%+0.1 \Omega$ 5%: $\pm 3\%+0.1 \Omega$
Robustness of Termination (Bending)	IEC60115-1-4.33 JIS-C5201-1-4.33	3mm deflection	1%: $\pm (0.5\%+0.05 \Omega)$ 5%: $\pm (1.0\%+0.05 \Omega)$



Thick Film High Voltage Chip Resistors(for 0805) Halogen-Free

Document No.	TRH-100S014F
Revise Date	2012/07/25
page number	5 / 9

7. Marking

7.1 ±5%(E24)

Resistance value is expressed by 3 digits, the first two digits represent the significant figures of nominal resistance value in Ω , and the third digit represents exponent for base of 10.

Ex. $106 = 10 \times 10^6 = 10000000 \Omega = 10M \Omega$

7.2 ±1% (E96)

Resistance value is expressed by 4 digits, the first three digits represent the significant figures of nominal resistance value in Ω , and the fourth digit represents exponent for base of 10.

Ex. $4993 = 499 \times 10^3 = 499000 \Omega = 499k \Omega$

8. Taping & Reel

8.1 Taping Dimensions

8.1.1 4 mm pitch paper

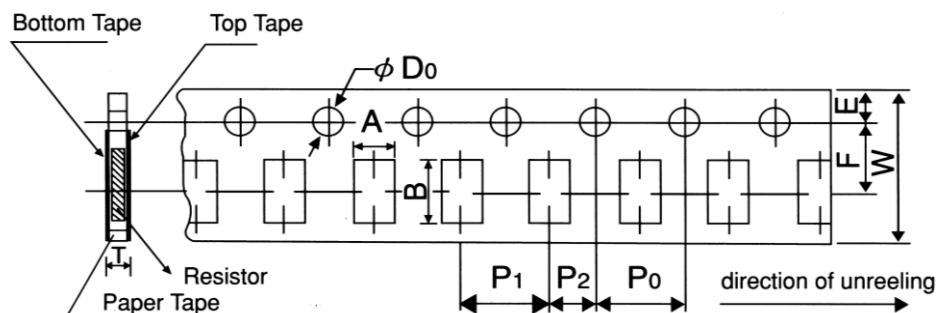

UNIT: mm

Packing	Type	A	B	W	F	E	P ₁	P ₂	P ₀	D ₀	T
Paper Tape	RH10	1.6±0.15	2.4±0.2	8.0±0.2	3.5±0.05	1.75±0.1	4.0±0.1	2.0±0.05	4.0±0.1	φ 1.5 ^{+0.1} ₋₀	0.84±0.1

Type series	Paper Tape	
	4 mm pitch	
	178mm/R	
RH	10	5000



**Thick Film High Voltage
Chip Resistors(for 0805)
Halogen-Free**

Document No.	TRH-100S014F
Revise Date	2012/07/25
page number	6 / 9

8.2 Reel Specifications

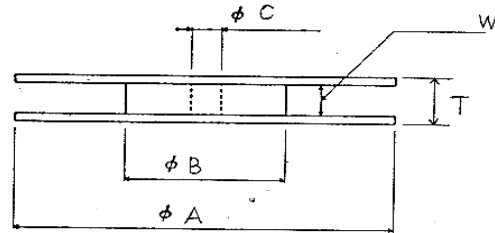
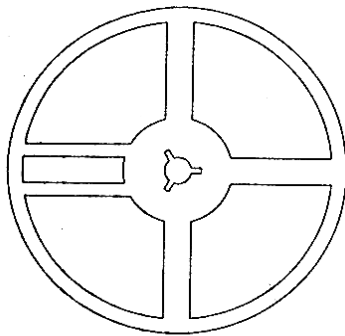

UNIT: mm

Type	ϕA	ϕB	ϕC	W	T
RH10	178.0 ± 2.0	60.0 ± 1.0	13.0 ± 1.0	9.0 ± 1.0	11.5 ± 1.0

8.3 Peel –off force :

Peel –off force of paper and blister tape is in accordance with “JIS-C5202 ”
that is , 0.1 to 0.7 N at a peel-off speed of 300 mm / minute.

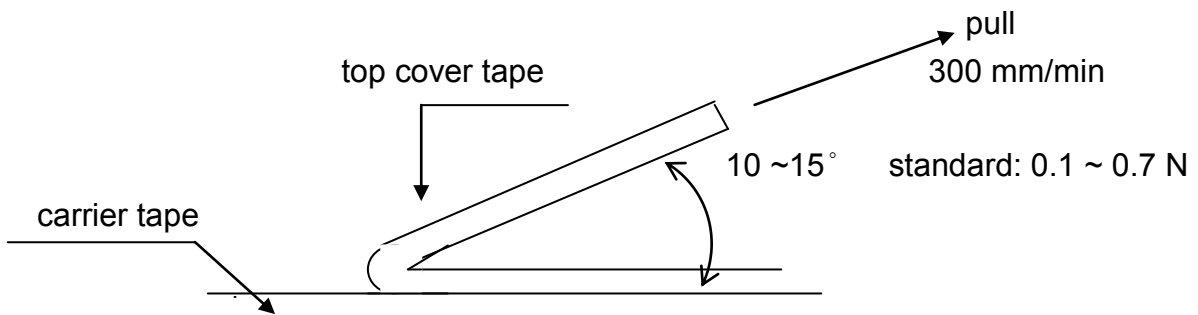



**Thick Film High Voltage
Chip Resistors(for 0805)
Halogen-Free**

Document No.	TRH-100S014F
Revise Date	2012/07/25
page number	7 / 9

9 Label

9.1 Manufacture Label :

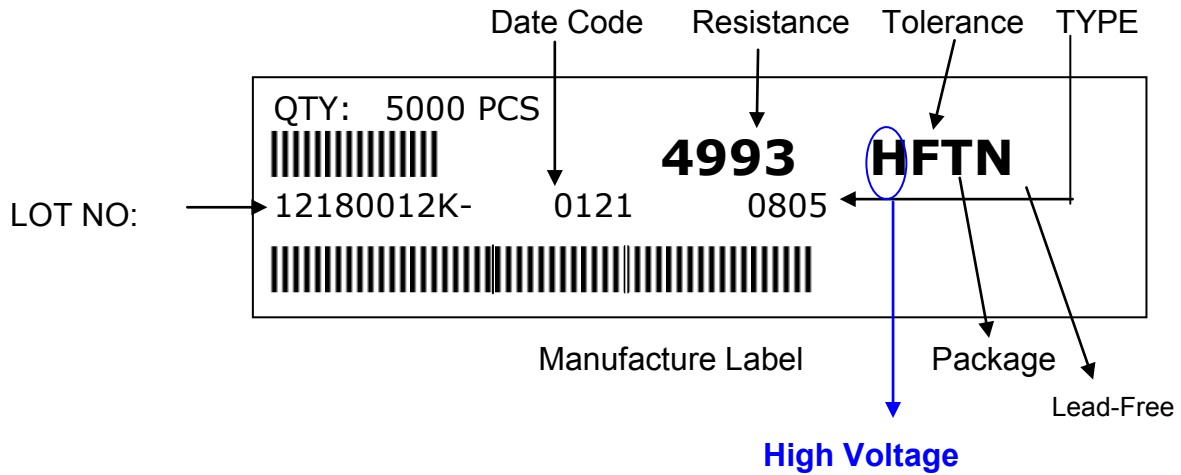

9.2 Customer Label (By customer request):

Lead-Free Products



10. Recommended land patterns

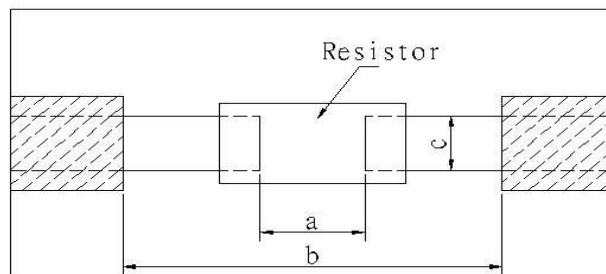

Land pattern		Dimension (mm)		
Type	Size	a	b	c
RH	10 (0805)	1.0~1.4	3.2~3.8	0.9~1.4



**Thick Film High Voltage
Chip Resistors(for 0805)
Halogen-Free**

Document No.	TRH-100S014F
Revise Date	2012/07/25
page number	8 / 9

11. Recommend IR – Reflow profile : (solder : Sn96.5 / Ag3 / Cu0.5)

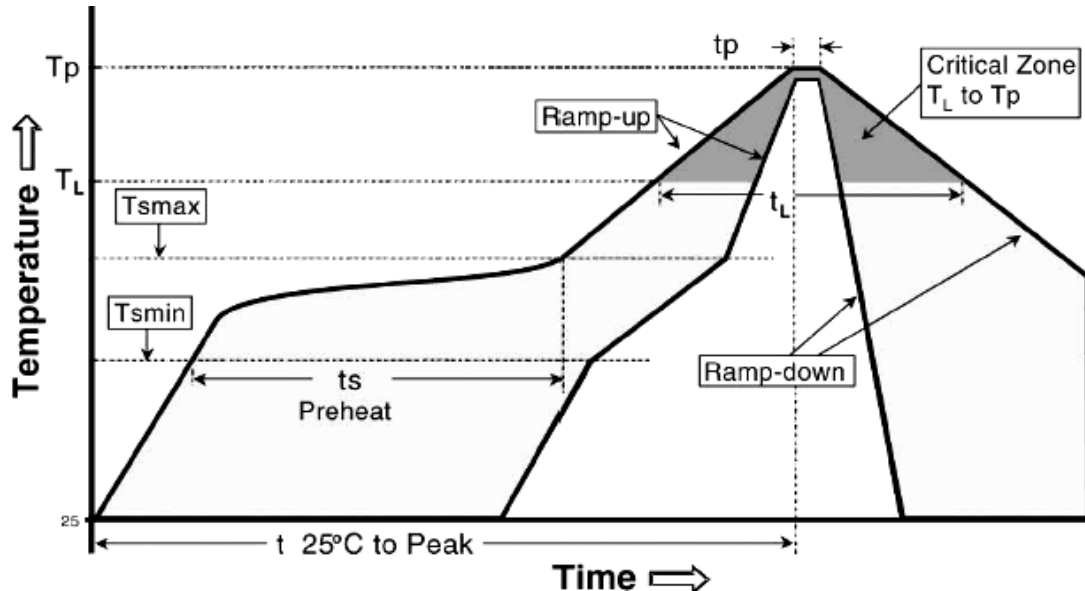

Profile Feature	Lead (Pb)-Free Assembly
Average ramp-up rate (T _{smax} to T _p)	3°C / second max.
Preheat - Temperature Min (T _{Amin}) - Temperature Max (T _{smax}) - Time (T _{Amin} to T _{smax}) (t _s)	150°C 200°C 60 -150 seconds
Time maintained above : - Temperature (T _l) - Time (T _l)	217°C 60-120 seconds
Peak Temperature (T _p)	260°C
Time within $\begin{matrix} +0 \\ -5 \end{matrix}$ °C of actual Peak Temperature (t _p) ²	10 seconds
Ramp-down Rate	6°C/second max.
Time 25°C to Peak Temperature	8minutes max.

Alloyed Re-flow times : 3 times

Remark : To avoid discoloration phenomena of chip on terminal electrodes,
please use N2 Re-flow furnace .



**Thick Film High Voltage
Chip Resistors(for 0805)
Halogen-Free**

Document No.	TRH-100S014F
Revise Date	2012/07/25
page number	9 / 9

12. Storage Conditions:

Temperature: 5°C~35°C, Humidity:40%~75%

13. Shelf Life:

2 years from manufacturing date.

14.ECN

Engineering Change Notice: The customer will be informed with ECN if there is significant modification on the characteristics and materials described in Approval Sheet.

15. Manufacturing Country & City :

TA-I TECHNOLOGY CO., LTD. (Taiwan- Tao Yuan)
Tel: 886-3-3246169 Fax : 886-3-3246167

Associated companies :

- (1) FORTUNE TASK RESISTOR FACTORY (China – Dongguan)
Tel : 86-769-8339-4790~3 Fax : 86-769-8339-4794
- (2) TA-I TECHNOLOGY (DONGGUAN) CO., LTD. (China –Dongguan)
Tel : 86-769-8339-4790~3 Fax : 86-769-8339-4794
- (3) TA-I TECHNOLOGY (SU ZHOU) CO., LTD. (China – Su Zhou)
Tel :86- 512-63457879 Fax : 86-512-63457869
- (4) TAI OHM ELECTRONICS (M) SDN. BHD. (Malaysia – Pulaupinang)
Tel :604- 3900480 Fax : 604-3901481
- (5) P.T.TAI ELECTRONICS Indonesia (Indonesia – Jakarta)
Tel :62-21-89830123 Fax : 62-21-89830703