

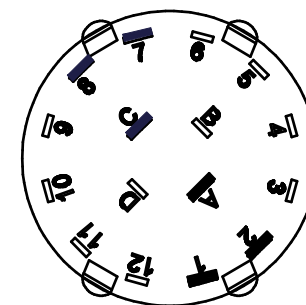

CONTACT CONFIGURATION
TIMING (BBM) NON-SHORTING

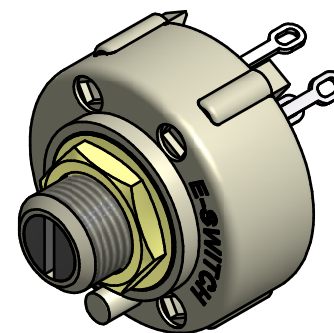

- NOTE:
1. ALL DIMENSIONS IN MM[INCH].
 2. GENERAL TOLERANCE: X.X=± 0.4
X.XX=± 0.25
 3. TERM. NOS. FOR REFERENCE ONLY.
 4. CONTACT MATERIAL: SILVER
 5. CONTACT RATING: 0.3A @ 125VAC
 6. OPERATING FORCE 500± 200g-cm
 7. OPERATING TEMP: -30°C TO 85°C
 - ▲8. CIRCUIT DP: 2 POSITION 30° INDEX. 
 9. DIELECTRIC STRENGTH: 1000V RMS MIN.@ SEA LEVEL.
 - ▲10. HARDWARE SUPPLIED ON SWITCH:
LOCKWASHER, HEXNUT, STOP RING
 11. ▲ DENOTES CRITICAL PARAMETER.
 12. 2002/95/EC (ROHS) COMPLIANT

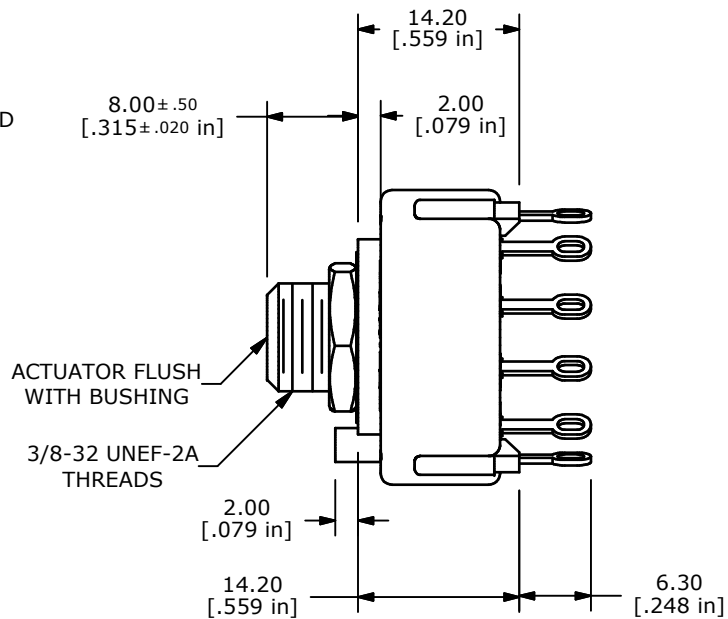
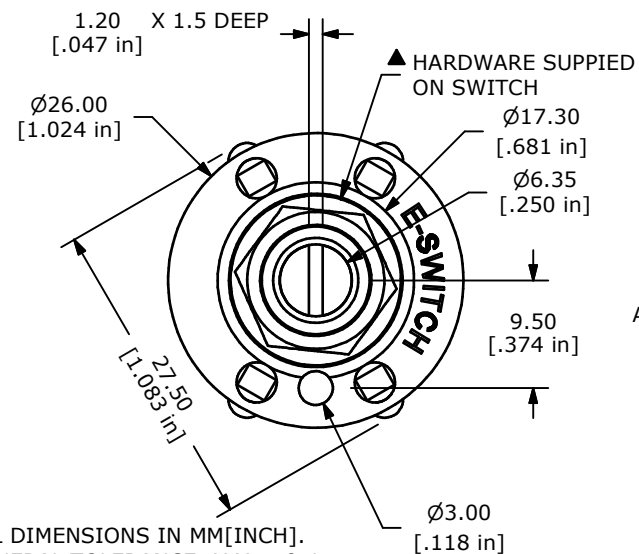

B	21505	CORRECT NOTE 8	7/8/14	EBP
A	21452	RELEASED FOR PRODUCTION	5/8/14	EBP
REV	PCR NO	DESCRIPTION	DATE	BY

TITLE KC22D0.001NLS				
SCALE	DATE 5/8/2014	DR EBP	DWG G530255	REV B

THE INFORMATION CONTAINED IN THIS DOCUMENT IS PROPRIETARY TO E-SWITCH AND IS NOT TO BE COPIED OR TRANSFERRED