

System Basis Chip

TLE9260QX

Mid-Range System Basis Chip Family

Body System IC with Integrated Voltage Regulators, Power Management Functions, HS-CAN Transceiver supporting CAN FD .

Featuring Multiple High-Side Switches and High-Voltage Wake Inputs.

Data Sheet

Rev. 1.1, 2014-09-26

Table of Contents

| | | |
|----------|---|-----------|
| 1 | Overview | 5 |
| 2 | Block Diagram | 7 |
| 3 | Pin Configuration | 8 |
| 3.1 | Pin Assignment | 8 |
| 3.2 | Pin Definitions and Functions | 9 |
| 3.3 | Hints for Unused Pins | 11 |
| 3.4 | Hints for Alternate Pin Functions | 11 |
| 4 | General Product Characteristics | 12 |
| 4.1 | Absolute Maximum Ratings | 12 |
| 4.2 | Functional Range | 14 |
| 4.3 | Thermal Resistance | 15 |
| 4.4 | Current Consumption | 16 |
| 5 | System Features | 20 |
| 5.1 | Block Description of State Machine | 21 |
| 5.1.1 | Device Configuration and SBC Init Mode | 22 |
| 5.1.1.1 | Device Configuration | 22 |
| 5.1.1.2 | SBC Init Mode | 24 |
| 5.1.2 | SBC Normal Mode | 25 |
| 5.1.3 | SBC Stop Mode | 26 |
| 5.1.4 | SBC Sleep Mode | 27 |
| 5.1.5 | SBC Restart Mode | 28 |
| 5.1.6 | SBC Fail-Safe Mode | 29 |
| 5.1.7 | SBC Development Mode | 30 |
| 5.2 | Wake Features | 31 |
| 5.2.1 | Cyclic Sense | 31 |
| 5.2.1.1 | Configuration and Operation of Cyclic Sense | 32 |
| 5.2.1.2 | Cyclic Sense in Low Power Mode | 35 |
| 5.2.2 | Cyclic Wake | 36 |
| 5.2.3 | Internal Timer | 37 |
| 5.3 | Supervision Features | 37 |
| 6 | Voltage Regulator 1 | 38 |
| 6.1 | Block Description | 38 |
| 6.2 | Functional Description | 39 |
| 6.3 | Electrical Characteristics | 40 |
| 7 | Voltage Regulator 2 | 43 |
| 7.1 | Block Description | 43 |
| 7.2 | Functional Description | 44 |
| 7.2.1 | Short to Battery Protection | 44 |
| 7.3 | Electrical Characteristics | 45 |
| 8 | High-Side Switch | 48 |
| 8.1 | Block Description | 48 |
| 8.2 | Functional Description | 48 |
| 8.2.1 | Over and Under Voltage Switch Off | 49 |
| 8.2.2 | Over Current Detection and Switch Off | 49 |
| 8.2.3 | Open Load Detection | 49 |
| 8.2.4 | HSx Operation in Different SBC Modes | 49 |

| | | |
|-----------|--|-----------|
| 8.2.5 | PWM and Timer Function | 50 |
| 8.3 | Electrical Characteristics | 51 |
| 9 | High Speed CAN Transceiver | 52 |
| 9.1 | Block Description | 52 |
| 9.2 | Functional Description | 52 |
| 9.2.1 | CAN OFF Mode | 54 |
| 9.2.2 | CAN Normal Mode | 54 |
| 9.2.3 | CAN Receive Only Mode | 55 |
| 9.2.4 | CAN Wake Capable Mode | 55 |
| 9.2.5 | TXD Time-out Feature | 57 |
| 9.2.6 | Bus Dominant Clamping | 57 |
| 9.2.7 | Under Voltage Detection | 57 |
| 9.3 | Electrical Characteristics | 58 |
| 10 | Wake and Voltage Monitoring Inputs | 64 |
| 10.1 | Block Description | 64 |
| 10.2 | Functional Description | 65 |
| 10.2.1 | Wake Input Configuration | 66 |
| 10.2.2 | Alternate Measurement Function with WK1 and WK2 | 67 |
| 10.2.2.1 | Block Description | 67 |
| 10.2.2.2 | Functional Description | 67 |
| 10.3 | Electrical Characteristics | 68 |
| 11 | Interrupt Function | 70 |
| 11.1 | Block and Functional Description | 70 |
| 11.2 | Electrical Characteristics | 72 |
| 12 | Fail Outputs | 73 |
| 12.1 | Block and Functional Description | 73 |
| 12.1.1 | General Purpose I/O Functionality of FO2 and FO3 as Alternate Function | 74 |
| 12.2 | Electrical Characteristics | 75 |
| 13 | Supervision Functions | 77 |
| 13.1 | Reset Function | 77 |
| 13.1.1 | Reset Output Description | 77 |
| 13.1.2 | Soft Reset Description | 78 |
| 13.2 | Watchdog Function | 79 |
| 13.2.1 | Time-Out Watchdog | 80 |
| 13.2.2 | Window Watchdog | 81 |
| 13.2.3 | Watchdog Setting Check Sum | 81 |
| 13.2.4 | Watchdog during SBC Stop Mode | 82 |
| 13.2.5 | Watchdog Start in SBC Stop Mode due to Bus Wake | 82 |
| 13.3 | VS Power On Reset | 83 |
| 13.4 | Under Voltage VS and VSHS | 84 |
| 13.5 | Over Voltage VSHS | 84 |
| 13.6 | VCC1 Over-/ Under Voltage and Under Voltage Prewarning | 84 |
| 13.6.1 | VCC1 Under Voltage and Under Voltage Prewarning | 84 |
| 13.6.2 | VCC1 Over Voltage | 85 |
| 13.7 | VCC1 Short Circuit Diagnostics | 86 |
| 13.8 | VCC2 Undervoltage and VCAN Undervoltage | 86 |
| 13.9 | Thermal Protection | 87 |
| 13.9.1 | Individual Thermal Shutdown | 87 |
| 13.9.2 | Temperature Prewarning | 88 |

Table of Contents

| | | |
|-----------|--|------------|
| 13.9.3 | SBC Thermal Shutdown | 88 |
| 13.10 | Electrical Characteristics | 89 |
| 14 | Serial Peripheral Interface | 92 |
| 14.1 | SPI Block Description | 92 |
| 14.2 | Failure Signalization in the SPI Data Output | 93 |
| 14.3 | SPI Programming | 95 |
| 14.4 | SPI Bit Mapping | 97 |
| 14.5 | SPI Control Registers | 100 |
| 14.5.1 | General Control Registers | 101 |
| 14.6 | SPI Status Information Registers | 118 |
| 14.6.1 | General Status Registers | 119 |
| 14.6.2 | Family and Product Information Register | 129 |
| 14.7 | Electrical Characteristics | 130 |
| 15 | Application Information | 132 |
| 15.1 | Application Diagram | 132 |
| 15.2 | ESD Tests | 136 |
| 15.3 | Thermal Behavior of Package | 137 |
| 16 | Package Outlines | 139 |
| 17 | Revision History | 140 |



1 Overview

Scalable System Basis Chip Family

- Product family with various products for complete scalable application coverage.
- Dedicated Data Sheets are available for the different product variants
- Complete compatibility (hardware and software) across the family
- TLE9263 with 2 LIN transceivers, 3 voltage regulators
- TLE9262 with 1 LIN transceiver, 3 voltage regulators
- TLE9261 without LIN transceivers, 3 voltage regulators
- TLE9260 without LIN transceivers, 2 voltage regulators
- Product variants for 5V (TLE926xQX) and 3.3V (TLE926xQXV33) output voltage for main voltage regulator
- CAN Partial Networking variants for 5V (TLE926x-3QX) and 3.3V (TLE926x-3QXV33) output voltage

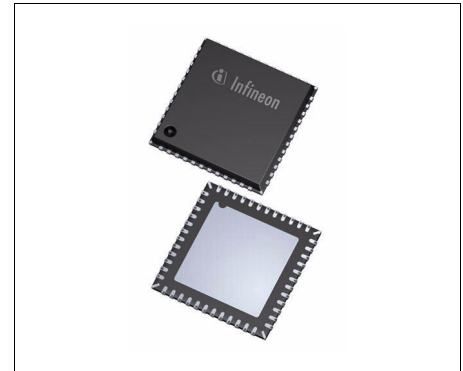

PG-VQFN-48-31

Device Description

The TLE9260QX is a monolithic integrated circuit in an exposed pad VQFN-48 (7mm x 7mm) power package with Lead Tip Inspection (LTI) feature to support Automatic Optical Inspection (AOI).

The device is designed for various CAN automotive applications as main supply for the microcontroller and as interface for a CAN bus network.

To support these applications, the System Basis Chip (SBC) provides the main functions, such as a 5V low-dropout voltage regulator (LDO) for e.g. a microcontroller supply, another 5V low-dropout voltage regulator with off-board protection for e.g. sensor supply, a HS-CAN transceiver supporting CAN FD for data transmission, high-side switches with embedded protective functions and a 16-bit Serial Peripheral Interface (SPI) to control and monitor the device. Also implemented are a configurable timeout / window watchdog circuit with a reset feature, three Fail Outputs and an under voltage reset feature.

The device offers low-power modes in order to minimize current consumption on applications that are connected permanently to the battery. A wake-up from the low-power mode is possible via a message on the buses, via the bi-level sensitive monitoring/wake-up inputs as well as via cyclic wake.

The device is designed to withstand the severe conditions of automotive applications.

| Type | Package | Marking |
|-----------|---------------|-----------|
| TLE9260QX | PG-VQFN-48-31 | TLE9260QX |

Key Features

- Very low quiescent current consumption in Stop- and Sleep Mode
- Periodic Cyclic Wake in SBC Normal- and Stop Mode
- Periodic Cyclic Sense in SBC Normal-, Stop- and Sleep Mode
- Low-Drop Voltage Regulator 5V, 250mA
- Low-Drop Voltage Regulator 5V, 100mA, protected features for off-board usage
- High-Speed CAN Transceiver:
 - fully compliant to ISO11898-2 and ISO11898-5
 - suitable for chokeless operation up to 500kbps
 - supporting CAN FD communication up to 2 Mbps
- Fully compliant to “Hardware Requirements for LIN, CAN and FlexRay Interfaces in Automotive Applications” Revision 1.3, 2012-05-04
- Four High-Side Outputs 7Ω typ.
- Dedicated supply pin for High-Side Outputs
- Two General Purpose High-Voltage In- and Outputs (GPIOs) configurable as add. Fail Outputs, Wake Inputs, Low-Side switches or High-Side switches
- Three universal High-Voltage Wake Inputs for voltage level monitoring
- Alternate High-Voltage Measurement Function, e.g. for battery voltage sensing
- Configurable wake-up sources
- Reset Output
- Configurable timeout and window watchdog
- Up to three Fail Outputs (depending on configuration)
- Over temperature and short circuit protection feature
- Wide supply input voltage and temperature range
- Software compatible to all SBC families TLE926x and TLE927x
- Green Product (RoHS compliant) & AEC Qualified
- PG-VQFN-48 leadless exposed-pad power package with Lead Tip Inspection (LTI) feature to support Automatic Optical Inspection (AOI)

2 Block Diagram

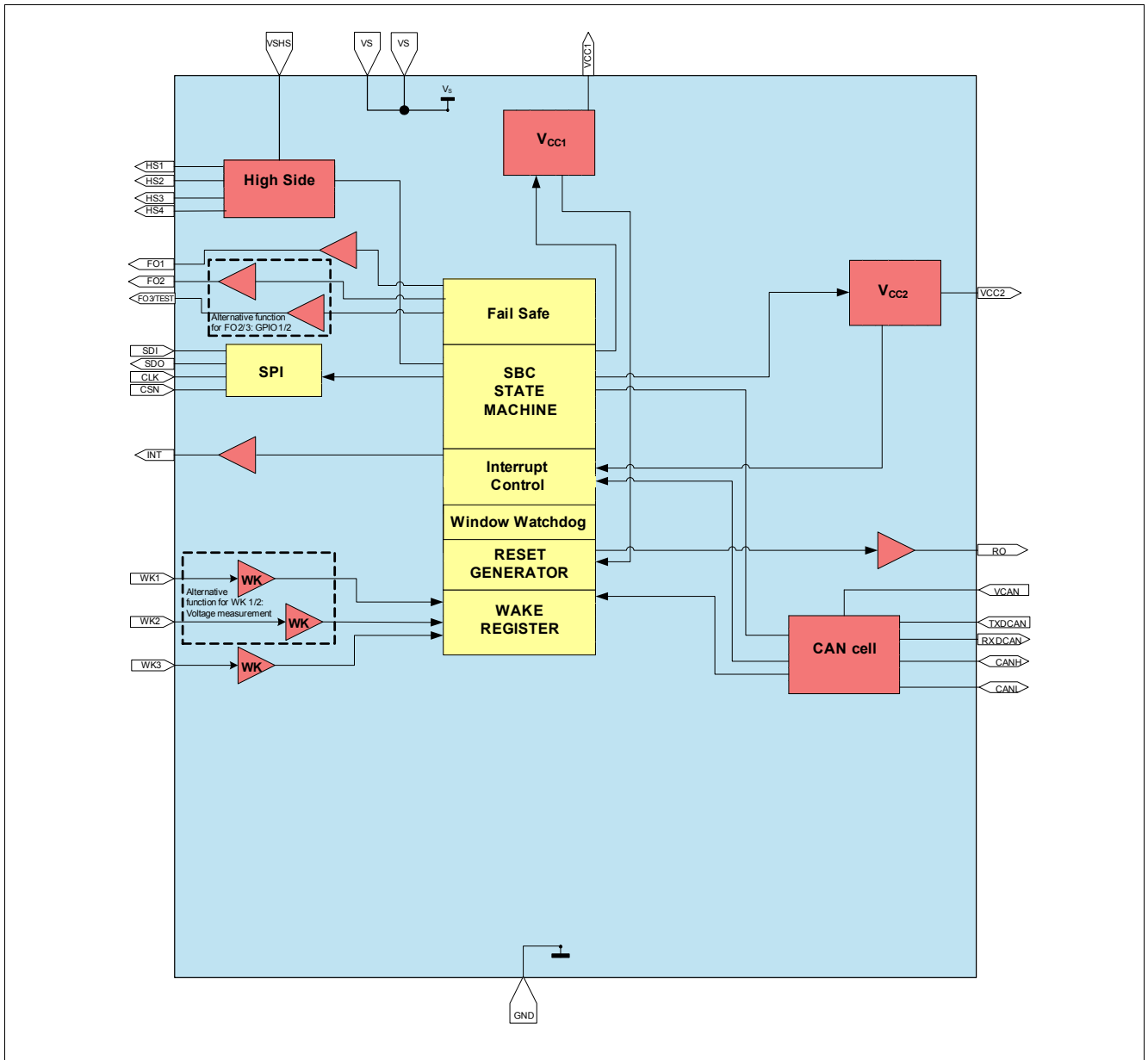

Figure 1 Block Diagram

3 Pin Configuration

3.1 Pin Assignment

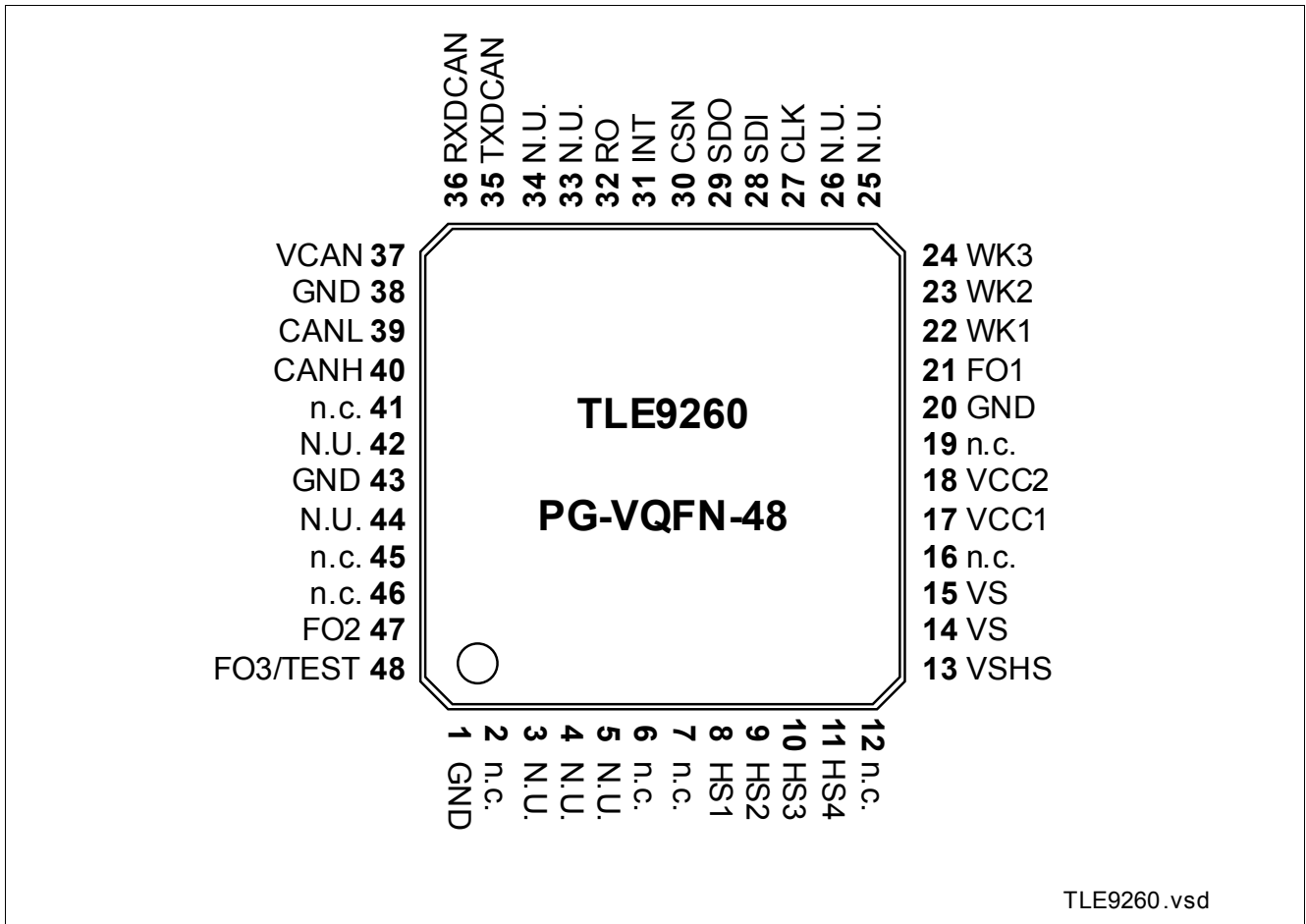

Figure 2 Pin Configuration

3.2 Pin Definitions and Functions

| Pin | Symbol | Function |
|-----|--------|--|
| 1 | GND | Ground |
| 2 | n.c. | not connected ; internally not bonded. |
| 3 | N.U. | Not Used ; Used for internal testing purpose. Do not connect, leave open |
| 4 | N.U. | Not Used ; Used for internal testing purpose. Do not connect, leave open |
| 5 | N.U. | Not Used ; Used for internal testing purpose. Do not connect, leave open |
| 6 | n.c. | not connected ; internally not bonded. |
| 7 | n.c. | not connected ; internally not bonded. |
| 8 | HS1 | High Side Output 1 ; typ. 7Ω |
| 9 | HS2 | High Side Output 2 ; typ. 7Ω |
| 10 | HS3 | High Side Output 3 ; typ. 7Ω |
| 11 | HS4 | High Side Output 4 ; typ. 7Ω |
| 12 | n.c. | not connected ; internally not bonded. |
| 13 | VSHS | Supply Voltage HS and GPIO1/2 in HS configuration; Supply voltage for High-Side Switches modules and respective UV-/OV supervision; Connected to battery voltage with reverse protection diode and filter against EMC; connect to VS if separate supply is not needed |
| 14 | VS | Supply Voltage; Supply voltage for chip internal supply and voltage regulators; Connected to Battery Voltage with external reverse protection Diode and Filter against EMC |
| 15 | VS | Supply Voltage; Supply voltage for chip internal supply and voltage regulators; Connected to Battery Voltage with external reverse protection Diode and Filter against EMC |
| 16 | n.c. | not connected ; internally not bonded. |
| 17 | VCC1 | Voltage Regulator Output 1 |
| 18 | VCC2 | Voltage Regulator Output 2 |
| 19 | n.c. | not connected ; internally not bonded. |
| 20 | GND | GND |
| 21 | FO1 | Fail Output 1 |
| 22 | WK1 | Wake Input 1 ; Alternative function: HV-measurement function input pin (only in combination with WK2, see Chapter 10.2.2) |
| 23 | WK2 | Wake Input 2 ; Alternative function: HV-measurement function output pin (only in combination with WK1, see Chapter 10.2.2) |
| 24 | WK3 | Wake Input 3 |
| 25 | N.U. | Not Used ; Used for internal testing purpose. Do not connect, leave open |
| 26 | N.U. | Not Used ; Used for internal testing purpose. Do not connect, leave open |
| 27 | CLK | SPI Clock Input |
| 28 | SDI | SPI Data Input; into SBC (=MOSI) |
| 29 | SDO | SPI Data Output; out of SBC (=MISO) |
| 30 | CSN | SPI Chip Select Not Input |

Pin Configuration

| Pin | Symbol | Function |
|-------------|----------|---|
| 31 | INT | Interrupt Output ; used as wake-up flag for microcontroller in SBC Stop or Normal Mode and for indicating failures. Active low. During start-up used to set the SBC configuration. External pull-up sets config 1/3, no external pull-up sets config 2/4. |
| 32 | RO | Reset Output |
| 33 | N.U. | Not Used ; Used for internal testing purpose. Do not connect, leave open |
| 34 | N.U. | Not Used ; Used for internal testing purpose. Do not connect, leave open |
| 35 | TXDCAN | Transmit CAN |
| 36 | RXDCAN | Receive CAN |
| 37 | VCAN | Supply Input; for internal HS-CAN cell |
| 38 | GND | GND |
| 39 | CANL | CAN Low Bus Pin |
| 40 | CANH | CAN High Bus Pin |
| 41 | n.c. | not connected ; internally not bonded. |
| 42 | N.U. | Not Used ; Used for internal testing purpose. Do not connect, leave open |
| 43 | GND | Ground |
| 44 | N.U. | Not Used ; Used for internal testing purpose. Do not connect, leave open |
| 45 | n.c. | not connected ; internally not bonded. |
| 46 | n.c. | not connected ; internally not bonded. |
| 47 | FO2 | Fail Output 2 - Side Indicator; Side indicators 1.25Hz 50% duty cycle output; Open drain. Active LOW. Alternative Function: GPIO1 ; configurable pin as WK, or LS, or HS supplied by VSHS (default is FO2, see also Chapter 12.1.1) |
| 48 | FO3/TEST | Fail Output 3 - Pulsed Light Output; Break/rear light 100Hz 20% duty cycle output; Open drain. Active LOW TEST ; Connect to GND to activate SBC Software Development Mode; Integrated pull-up resistor. Connect to VS with pull-up resistor or leave open for normal operation. Alternative Function: GPIO2 ; configurable pin as WK, or LS, or HS supplied by VSHS (default is FO3, see also Chapter 12.1.1) |
| Cooling Tab | GND | Cooling Tab - Exposed Die Pad; For cooling purposes only, do not use as an electrical ground. ¹⁾ |

1) The exposed die pad at the bottom of the package allows better power dissipation of heat from the SBC via the PCB. The exposed die pad is not connected to any active part of the IC and can be left floating or it can be connected to GND (recommended) for the best EMC performance.

Note: all VS Pins must be connected to battery potential or insert a reverse polarity diodes where required; all GND pins as well as the Cooling Tab must be connected to one common GND potential;

3.3 Hints for Unused Pins

It must be ensured that the correct configurations are also selected, i.e. in case functions are not used that they are disabled via SPI:

- WK1/2/3: connect to GND and disable WK inputs via SPI
- HSx: leave open
- CANH/L, RXDCAN, TXDCAN: leave all pins open
- RO / FOx: leave open
- INT: leave open
- TEST: connect to GND during power-up to activate SBC Development Mode; connect to VS or leave open for normal user mode operation
- VCC2: leave open and keep disabled
- VCAN: connect to VCC1
- n.c.: not connected; internally not bonded; connect to GND
- **N.U.:** Not Used; Used for internal testing purposes only. Do not connect, leave open, i.e. not connected to any potential on the board. In case N.U. pins are connected on the board an open bridge has to be foreseen to avoid external disturbances. The bridge can be shorted by a 0 Ω resistance if signal is needed.

3.4 Hints for Alternate Pin Functions

In case of alternate pin functions, selectable via SPI, it must be ensured that the correct configurations are also selected via SPI, in case it is not done automatically. Please consult the respective chapter. In addition, following topics shall be considered:

- WK1..2: The pins can be either used as HV wake / voltage monitoring inputs or for a voltage measurement function (via bit **WK_MEAS**). In the second case, the WK1..2 pins shall not be used / assigned for any wake detection nor cyclic sense functionality, i.e. WK1 and WK2 must be disabled in the register **WK_CTRL_2** and the level information is to be ignored in the register **WK_LVL_STAT**.
- FO2..3: The pins can also be configured as GPIOs in the **GPIO_CTRL** register. In this case, the pins shall not be used for any fail output functionality. The default function after Power on Reset (POR) is FOx.

4 General Product Characteristics

4.1 Absolute Maximum Ratings

Table 1 Absolute Maximum Ratings¹⁾

$T_j = -40\text{ °C}$ to $+150\text{ °C}$; all voltages with respect to ground, positive current flowing into pin (unless otherwise specified)

| Parameter | Symbol | Values | | | Unit | Note / Test Condition | Number |
|--|--------------------|--------|------|-----------------|-------------|---|----------|
| | | Min. | Typ. | Max. | | | |
| Voltages | | | | | | | |
| Supply Voltage (VS, VSHS) | $V_{S_x, \max}$ | -0.3 | – | 28 | V | – | P_4.1.1 |
| Supply Voltage (VS, VSHS) | $V_{S_x, \max}$ | -0.3 | – | 40 | V | Load Dump, max. 400 ms | P_4.1.2 |
| Voltage Regulator 1 | $V_{CC1, \max}$ | -0.3 | – | 5.5 | V | – | P_4.1.3 |
| Voltage Regulator 2 | $V_{CC2, \max}$ | -0.3 | – | 28 | V | $V_{CC2} = 40V$ for Load Dump, max. 400 ms; | P_4.1.4 |
| Wake Inputs WK1..3 | $V_{WK, \max}$ | -0.3 | – | 40 | V | – | P_4.1.6 |
| Fail Pin FO1 | $V_{FO1, \max}$ | -0.3 | – | 40 | V | – | P_4.1.7 |
| Fail Pins FO2, FO3/TEST | $V_{FO2_3, \max}$ | -0.3 | – | $V_S + 0.3$ | V | – | P_4.1.23 |
| CANH, CANL | $V_{BUS, \max}$ | -27 | – | 40 | V | – | P_4.1.8 |
| Logic Input Pins (CSN, CLK, SDI, TXDCAN) | $V_{I, \max}$ | -0.3 | – | $V_{CC1} + 0.3$ | V | – | P_4.1.9 |
| Logic Output Pins (SDO, RO, INT, RXDCAN) | $V_{O, \max}$ | -0.3 | – | $V_{CC1} + 0.3$ | V | – | P_4.1.10 |
| VCAN Input Voltage | $V_{VCAN, \max}$ | -0.3 | – | 5.5 | V | – | P_4.1.11 |
| High Side 1...4 | $V_{HS, \max}$ | -0.3 | – | $V_{SHS} + 0.3$ | V | – | P_4.1.12 |
| Currents | | | | | | | |
| Wake input WK1 | $I_{WK1, \max}$ | 0 | – | 500 | μA | ²⁾ | P_4.1.13 |
| Wake input WK2 | $I_{WK2, \max}$ | -500 | – | 0 | μA | ²⁾ | P_4.1.14 |
| Temperatures | | | | | | | |
| Junction Temperature | T_j | -40 | – | 150 | $^{\circ}C$ | – | P_4.1.15 |
| Storage Temperature | T_{stg} | -55 | – | 150 | $^{\circ}C$ | – | P_4.1.16 |
| ESD Susceptibility | | | | | | | |
| ESD Resistivity | $V_{ESD,11}$ | -2 | – | 2 | kV | HBM ³⁾ | P_4.1.17 |
| ESD Resistivity to GND, HSx | $V_{ESD,12}$ | -2 | – | 2 | kV | HBM ³⁾ | P_4.1.18 |
| ESD Resistivity to GND, CANH, CANL | $V_{ESD,13}$ | -8 | – | 8 | kV | HBM ⁴⁾³⁾ | P_4.1.19 |

Table 1 Absolute Maximum Ratings¹⁾ (cont'd)

$T_j = -40\text{ °C}$ to $+150\text{ °C}$; all voltages with respect to ground, positive current flowing into pin (unless otherwise specified)

| Parameter | Symbol | Values | | | Unit | Note / Test Condition | Number |
|--|--------------|--------|------|------|------|-----------------------|----------|
| | | Min. | Typ. | Max. | | | |
| ESD Resistivity to GND | $V_{ESD,21}$ | -500 | – | 500 | V | CDM ⁵⁾ | P_4.1.20 |
| ESD Resistivity Pin 1, 12,13,24,25,36,37,48 (corner pins) to GND | $V_{ESD,22}$ | -750 | – | 750 | V | CDM ⁵⁾ | P_4.1.21 |

- 1) Not subject to production test, specified by design.
- 2) Applies only if WK1 and WK2 are configured as alternative HV-measurement function
- 3) ESD susceptibility, HBM according to ANSI/ESDA/JEDEC JS-001 (1.5 kΩ, 100 pF)
- 4) For ESD “GUN” Resistivity 6KV (according to IEC61000-4-2 “gun test” (150pF, 330Ω)), will be shown in Application Information and test report will be provided from IBEE
- 5) ESD susceptibility, Charged Device Model “CDM” EIA/JESD22-C101 or ESDA STM5.3.1

Notes

1. Stresses above the ones listed here may cause permanent damage to the device. Exposure to absolute maximum rating conditions for extended periods may affect device reliability.
2. Integrated protection functions are designed to prevent IC destruction under fault conditions described in the data sheet. Fault conditions are considered as “outside” normal operating range. Protection functions are not designed for continuous repetitive operation.

4.2 Functional Range

Table 2 Functional Range

| Parameter | Symbol | Values | | | Unit | Note / Test Condition | Number |
|----------------------|----------------|-----------|------|------|------|---|---------|
| | | Min. | Typ. | Max. | | | |
| Supply Voltage | $V_{S,func}$ | V_{POR} | – | 28 | V | ¹⁾ V_{POR} see section Chapter 13.10 | P_4.2.1 |
| CAN Supply Voltage | $V_{CAN,func}$ | 4.75 | – | 5.25 | V | – | P_4.2.3 |
| SPI frequency | f_{SPI} | – | – | 4 | MHz | see Chapter 14.7 for $f_{SPI,max}$ | P_4.2.4 |
| Junction Temperature | T_j | -40 | – | 150 | °C | – | P_4.2.5 |

1) Including Power-On Reset, Over- and Under voltage Protection

Note: Within the functional range the IC operates as described in the circuit description. The electrical characteristics are specified within the conditions given in the related electrical characteristics table.

Device Behavior Outside of Specified Functional Range:

- $28V < V_{S,func} < 40V$: Device will still be functional including the state machine; the specified electrical characteristics might not be ensured anymore. The regulators VCC1/2/3 are working properly, however, a thermal shutdown might occur due to high power dissipation. HSx switches might be turned OFF depending on VSHS_OV configurations. The specified SPI communication speed is ensured; the absolute maximum ratings are not violated, however the device is not intended for continuous operation of $V_S > 28V$. The device operation at high junction temperatures for long periods might reduce the operating life time;
- $V_{CAN} < 4.75V$: The undervoltage bit **VCAN_UV** will be set in the SPI register **BUS_STAT_1** and the transmitter will be disabled as long as the UV condition is present;
- $5.25V < V_{CAN} < 5.50V$: CAN transceiver still functional. However, the communication might fail due to out-of-spec operation;
- $V_{POR,f} < V_S < 5.5V$: Device will still be functional; the specified electrical characteristics might not be ensured anymore.
 - The voltage regulators will enter the low-drop operation mode,
 - A VCC1_UV reset could be triggered depending on the Vrtx settings,
 - HSx switch behavior will depend on the respective configuration:
 - **HS_UV_SD_EN** = '0' (default): HSx will be turned OFF for $VSHS < VSHS_{UV}$ and will stay OFF;
 - **HS_UV_SD_EN** = '1': HSx stays on as long as possible. An unwanted over current shut down may occur. OC shut down bit set and the respective HSx switch will stay OFF;
 - FOx outputs will remain ON if they were enabled before $V_S > 5.5V$,
 - The specified SPI communication speed is ensured.

4.3 Thermal Resistance

Table 3 Thermal Resistance¹⁾

| Parameter | Symbol | Values | | | Unit | Note / Test Condition | Number |
|-----------------------------|-------------|--------|------|------|------|-----------------------|---------|
| | | Min. | Typ. | Max. | | | |
| Junction to Soldering Point | R_{thJSP} | – | 6 | – | K/W | Exposed Pad | P_4.3.1 |
| Junction to Ambient | R_{thJA} | – | 33 | – | K/W | ²⁾ | P_4.3.2 |

1) Not subject to production test, specified by design.

2) According to Jedec JESD51-2,-5,-7 at natural convection on FR4 2s2p board for 1.5W. Board: 76.2x114.3x1.5mm³ with 2 inner copper layers (35µm thick), with thermal via array under the exposed pad contacting the first inner copper layer and 300mm² cooling area on the bottom layer (70µm).

4.4 Current Consumption

Table 4 Current Consumption

 Current consumption values are specified at $T_j = 25^\circ\text{C}$, $V_S = 13.5\text{V}$, all outputs open (unless otherwise specified)

| Parameter | Symbol | Values | | | Unit | Note / Test Condition | Number |
|---|--------------------------|--------|------|------|---------------|--|----------|
| | | Min. | Typ. | Max. | | | |
| SBC Normal Mode | | | | | | | |
| Normal Mode current consumption | I_{Normal} | – | 3.5 | 6.5 | mA | $V_S = 5.5\text{ V to }28\text{ V}$; $T_j = -40^\circ\text{C to }+150^\circ\text{C}$; VCC2, CAN, HSx = OFF | P_4.4.1 |
| SBC Stop Mode | | | | | | | |
| Stop Mode current consumption | $I_{\text{Stop}_{1,25}}$ | – | 44 | 60 | μA | ¹⁾ VCC2, HSx = OFF; CAN, WKx not wake capable; Watchdog = OFF; no load on VCC1; $I_{\text{PEAK_TH}} = '0'$ | P_4.4.2 |
| Stop Mode current consumption | $I_{\text{Stop}_{1,85}}$ | – | 50 | 70 | μA | ¹⁾²⁾ $T_j = 85^\circ\text{C}$; VCC2, HSx = OFF; CAN, WKx not wake capable; Watchdog = OFF; no load on VCC1; $I_{\text{PEAK_TH}} = '0'$ | P_4.4.3 |
| Stop Mode current consumption (high active peak threshold) | $I_{\text{Stop}_{2,25}}$ | – | 64 | 90 | μA | ¹⁾ VCC2, HSx = OFF; CAN, WKx not wake capable; Watchdog = OFF; no load on VCC1; $I_{\text{PEAK_TH}} = '1'$ | P_4.4.35 |
| Stop Mode current consumption (high active peak threshold) | $I_{\text{Stop}_{2,85}}$ | – | 70 | 100 | μA | ¹⁾²⁾ $T_j = 85^\circ\text{C}$; VCC2, HSx = OFF; CAN, WKx not wake capable; Watchdog = OFF; no load on VCC1; $I_{\text{PEAK_TH}} = '1'$ | P_4.4.36 |
| SBC Sleep Mode | | | | | | | |
| Sleep Mode current consumption | $I_{\text{Sleep}_{25}}$ | – | 15 | 25 | μA | VCC2, HSx = OFF; CAN, WKx not wake capable | P_4.4.5 |
| Sleep Mode current consumption | $I_{\text{Sleep}_{85}}$ | – | 25 | 35 | μA | ²⁾ $T_j = 85^\circ\text{C}$; VCC2, HSx = OFF; CAN, WKx not wake capable | P_4.4.6 |

General Product Characteristics
Table 4 Current Consumption (cont'd)

 Current consumption values are specified at $T_j = 25^\circ\text{C}$, $V_S = 13.5\text{V}$, all outputs open (unless otherwise specified)

| Parameter | Symbol | Values | | | Unit | Note / Test Condition | Number |
|--|----------------------------|--------|------|------|---------------|---|----------|
| | | Min. | Typ. | Max. | | | |
| Feature Incremental Current Consumption | | | | | | | |
| Current consumption for CAN module, recessive state | $I_{\text{CAN,rec}}$ | – | 2 | 3 | mA | SBC Normal/Stop Mode; CAN Normal Mode; VCC1 connected to VCAN; VTXDCAN = VCC1; no RL on CAN | P_4.4.7 |
| Current consumption for CAN module, dominant state | $I_{\text{CAN,dom}}$ | – | 3 | 4.5 | mA | ²⁾ SBC Normal/Stop Mode; CAN Normal Mode; VCC1 connected to VCAN; VTXDCAN = GND; no RL on CAN | P_4.4.8 |
| Current consumption for CAN module, Receive Only Mode | $I_{\text{CAN,RcvOnly}}$ | – | 0.9 | 1.2 | mA | ²⁾ SBC Normal/Stop Mode; CAN Receive Only Mode; VCC1 connected to VCAN; VTXDCAN = VCC1; no RL on CAN | P_4.4.9 |
| Current consumption for WK1..3 wake capability (all wake inputs) | $I_{\text{Wake,WKx,25}}$ | – | 0.2 | 2 | μA | ³⁾⁴⁾⁵⁾ SBC Sleep Mode; WK1..3 wake capable (all WKx enabled); CAN = OFF | P_4.4.13 |
| Current consumption for WK1..3 wake capability (all wake inputs) | $I_{\text{Wake,WKx,85}}$ | – | 0.5 | 3 | μA | ²⁾³⁾⁴⁾⁵⁾ SBC Sleep Mode; $T_j = 85^\circ\text{C}$; WK1..3 wake capable; (all WKx enabled); CAN = OFF | P_4.4.14 |
| Current consumption for CAN wake capability | $I_{\text{Wake,CAN,25}}$ | – | 4.5 | 6 | μA | ³⁾ SBC Sleep Mode; CAN wake capable; WK1..3 | P_4.4.17 |
| Current consumption for CAN wake capability | $I_{\text{Wake,CAN,85}}$ | – | 5.5 | 7 | μA | ²⁾³⁾ SBC Sleep Mode; $T_j = 85^\circ\text{C}$; CAN wake capable; WK1..3 | P_4.4.18 |
| VCC2 Normal Mode current consumption | $I_{\text{Normal,VCC2}}$ | – | 2.5 | 3.5 | mA | $V_S = 5.5\text{ V to }28\text{ V}$; $T_j = -40^\circ\text{C to }+150^\circ\text{C}$; VCC2 = ON (no load) | P_4.4.32 |
| Current consumption for VCC2 in SBC Sleep Mode | $I_{\text{Sleep,VCC2,25}}$ | – | 25 | 35 | μA | ¹⁾³⁾ SBC Sleep Mode; VCC2 = ON (no load); CAN, WK1..3 = OFF | P_4.4.19 |

Table 4 Current Consumption (cont'd)

Current consumption values are specified at $T_j = 25^\circ\text{C}$, $V_S = 13.5\text{V}$, all outputs open (unless otherwise specified)

| Parameter | Symbol | Values | | | Unit | Note / Test Condition | Number |
|--|----------------------------|--------|------|------|---------------|--|----------|
| | | Min. | Typ. | Max. | | | |
| Current consumption for VCC2 in SBC Sleep Mode | $I_{\text{Sleep,VCC2,85}}$ | – | 30 | 40 | μA | ¹⁾²⁾³⁾ SBC Sleep Mode; $T_j = 85^\circ\text{C}$; VCC2 = ON (no load); CAN, WK1..3 = OFF | P_4.4.20 |
| Current consumption for HSx in SBC Stop Mode | $I_{\text{Stop,HSx,25}}$ | – | 525 | 650 | μA | ³⁾⁶⁾ SBC Stop Mode; Cyclic Sense & HSx= ON (no load); CAN, WK1..3 = OFF | P_4.4.33 |
| Current consumption for HSx in SBC Stop Mode | $I_{\text{Stop,HSx,85}}$ | – | 575 | 700 | μA | ²⁾³⁾⁶⁾ SBC Stop Mode; $T_j = 85^\circ\text{C}$; Cyclic Sense & HSx = ON (no load); CAN, WK1..3 = OFF | P_4.4.34 |
| Current consumption for cyclic sense function | $I_{\text{Stop,CS25}}$ | – | 20 | 26 | μA | ³⁾⁷⁾⁸⁾ SBC Stop Mode; WD = OFF | P_4.4.23 |
| Current consumption for cyclic sense function | $I_{\text{Stop,CS85}}$ | – | 24 | 35 | μA | ²⁾³⁾⁷⁾⁸⁾ SBC Stop Mode; $T_j = 85^\circ\text{C}$; WD = OFF | P_4.4.27 |
| Current consumption for watchdog active in Stop Mode | $I_{\text{Stop,WD25}}$ | – | 20 | 26 | μA | ²⁾ SBC Stop Mode; Watchdog running | P_4.4.30 |
| Current consumption for watchdog active in Stop Mode | $I_{\text{Stop,WD85}}$ | – | 24 | 35 | μA | ²⁾ SBC Stop Mode; $T_j = 85^\circ\text{C}$; Watchdog running | P_4.4.31 |
| Current consumption for active fail outputs (FO1..3) | $I_{\text{Stop,FOx}}$ | – | 1.0 | 2.0 | mA | ²⁾ all SBC Modes; $T_j = 25^\circ\text{C}$; FOx = ON (no load); | P_4.4.24 |

- 1) If the load current on VCC1 will exceed the configured VCC1 active peak threshold $I_{VCC1,peak1,r}$ or $I_{VCC1,peak2,r}$ the current consumption will increase by typ. 2.9mA to ensure optimum dynamic load behavior. Same applies to VCC2.. See also [Chapter 6](#), [Chapter 7](#).
- 2) Not subject to production test, specified by design.
- 3) Current consumption adders of features defined for SBC Sleep Mode also apply for SBC Stop Mode and vice versa (unless otherwise specified).
- 4) No pull-up or pull-down configuration selected.
- 5) The specified WKx current consumption adder for wake capability applies regardless how many WK inputs are activated.
- 6) A typ. 75 μA / max 125 μA ($T_j = 85^\circ\text{C}$) adder applies for every additionally activated HSx switch in SBC Stop Mode; In SBC Normal Mode every HSx switch consumes the typ. 75 μA / max 125 μA ($T_j = 85^\circ\text{C}$) without the initial adder because the biasing is already enabled.
- 7) HS1 used for cyclic sense, Timer 2, 20ms period, 0.1ms on-time, no load on HS1.

In general the current consumption adder for cyclic sense in SBC Stop Mode can be calculated with below equation:
 $I_{\text{Stop,CS}} = 18\mu\text{A} + (525\mu\text{A} * t_{\text{ON}}/T_{\text{Per}})$

- 8) Also applies to Cyclic Wake

Note: There is no additional current consumption contribution due to PWM generators.

5 System Features

This chapter describes the system features and behavior of the TLE9260QX:

- State machine
- SBC mode control
- Device configuration
- State of supply and peripherals
- System functions such as cyclic sense or cyclic wake
- Supervision and diagnosis functions

The System Basis Chip (SBC) offers six operating modes:

- SBC Init Mode: Power-up of the device and after a soft reset,
- SBC Normal Mode: The main operating mode of the device,
- SBC Stop Mode: The first-level power saving mode with the main voltage regulator VCC1 enabled,
- SBC Sleep Mode: The second-level power saving mode with VCC1 disabled,
- SBC Restart Mode: An intermediate mode after a wake event from SBC Sleep or Fail-Safe Mode or after a failure (e.g. WD failure, VCC1 under voltage reset) to bring the microcontroller into a defined state via a reset. Once the failure condition is not present anymore the device will automatically change to SBC Normal Mode after a delay time (t_{RD1}).
- SBC Fail-Safe Mode: A safe-state mode after critical failures (e.g. WD failure, VCC1 under voltage reset) to bring the system into a safe state and to ensure a proper restart of the system. VCC1 is disabled. It is a permanent state until either a wake event (via CAN or WKx) occurs or the over temperature condition is not present anymore.

A special mode, called SBC Development Mode, is available during software development or debugging of the system. All above mentioned operating modes can be accessed in this mode. However, the watchdog counter is stopped and does not need to be triggered. This mode can be accessed by setting the TEST pin to GND during SBC Init Mode.

The device can be configured via hardware (external component) to determine the device behavior after a watchdog trigger failure. See [Chapter 5.1.1](#) for further information.

The System Basis Chip is controlled via a 16-bit SPI interface. A detailed description can be found in [Chapter 14](#). The configuration as well as the diagnosis is handled via the SPI. The SPI mapping of the TLE9260QX is compatible to other devices of the TLE926x and TLE927x families.

5.1 Block Description of State Machine

The different SBC Modes are selected via SPI by setting the respective SBC **MODE** bits in the register **M_S_CTRL**. The SBC **MODE** bits are cleared when going through SBC Restart Mode and thus always show the current SBC mode.

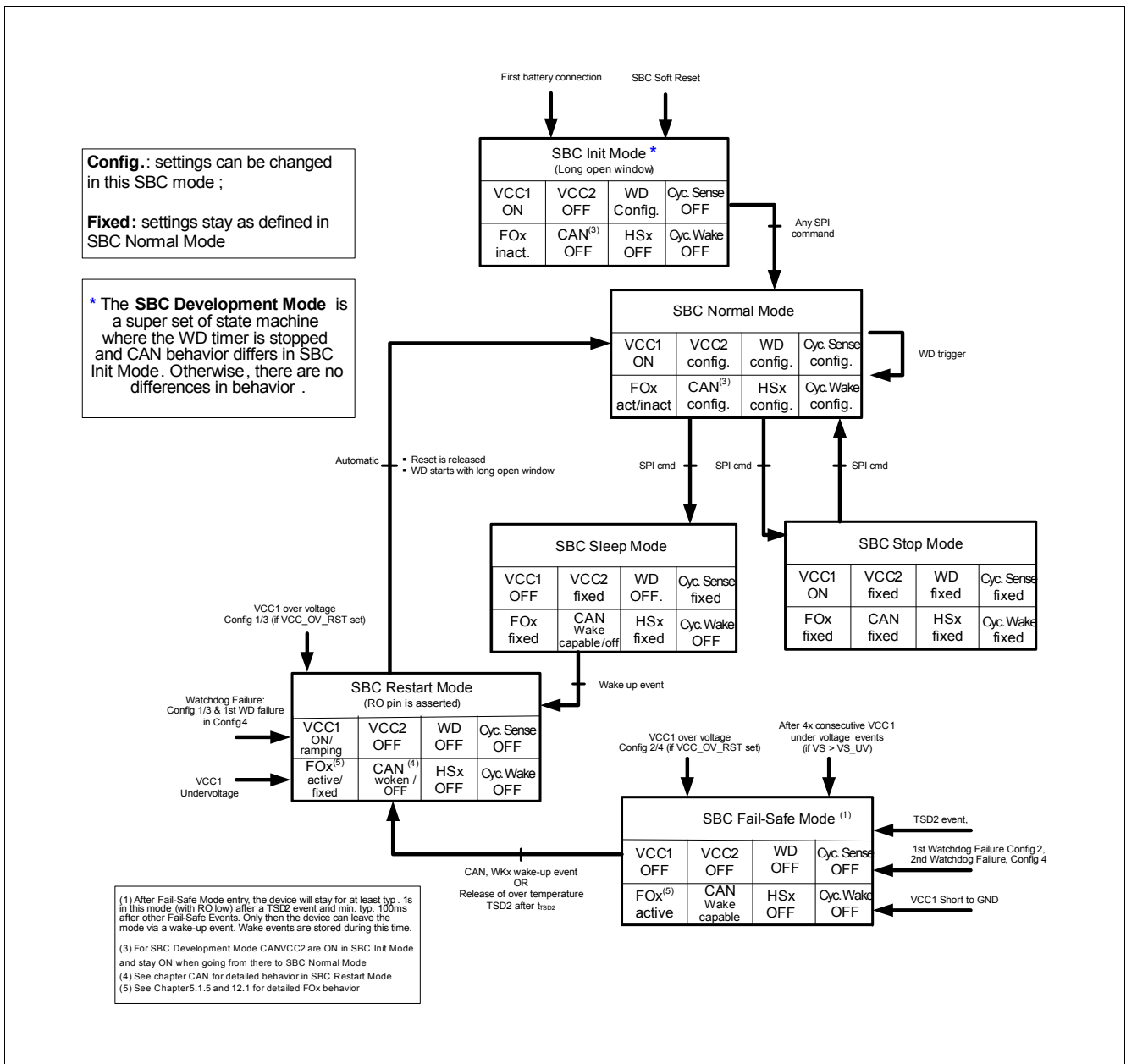

Figure 3 State Diagram showing the SBC Operating Modes

5.1.1 Device Configuration and SBC Init Mode

The SBC starts up in SBC Init Mode after crossing the power-on reset $V_{POR,r}$ threshold (see also [Chapter 13.3](#)) and the watchdog will start with a long open window (t_{LW}).

During this power-on phase following configurations are stored in the device:

- The device behavior regarding a watchdog trigger failure and a VCC1 over voltage condition is determined by the external circuitry on the INT pin (see below)
- The selection of the normal device operation or the SBC Software Development Mode (watchdog disabled for debugging purposes) will be set depending on the voltage level of the FO3/TEST pin (see also [Chapter 5.1.7](#)).

5.1.1.1 Device Configuration

The configuration selection is intended to select the SBC behavior regarding a watchdog trigger failure. Depending on the requirements of the application, the VCC1 output shall be switched OFF and the device shall go to SBC Fail-Safe Mode in case of a watchdog failure (1 or 2 fails). To set this configuration (Config 2/4), the INT pin does not need an external pull-up resistor. In case VCC1 should not be switched OFF (Config 1/3), the INT pin needs to have an external pull-up resistor connected to VCC1 (see application diagram in [Chapter 15.1](#)).

Figure 5 shows the timing diagram of the hardware configuration selection. The hardware configuration is defined during SBC Init Mode. The INT pin is internally pulled LOW with a weak pull-down resistor during the reset delay time t_{RD1} , i.e. after VCC1 crosses the reset threshold $V_{RT1,r}$ and before the RO pin goes HIGH. The INT pin is monitored during this time (with a continuous filter time of $t_{CFG,F}$) and the configuration (depending on the voltage level at INT) is stored at the rising edge of RO.

*Note: If the **POR** bit is not cleared then the internal pull-down resistor will be reactivated every time RO is pulled LOW the configuration will be updated at the rising edge of RO. Therefore it is recommended to clear the **POR** bit right after initialization. In case there is no stable signal at INT, then the default value '0' will taken as the config select value = SBC Fail-Safe Mode.*

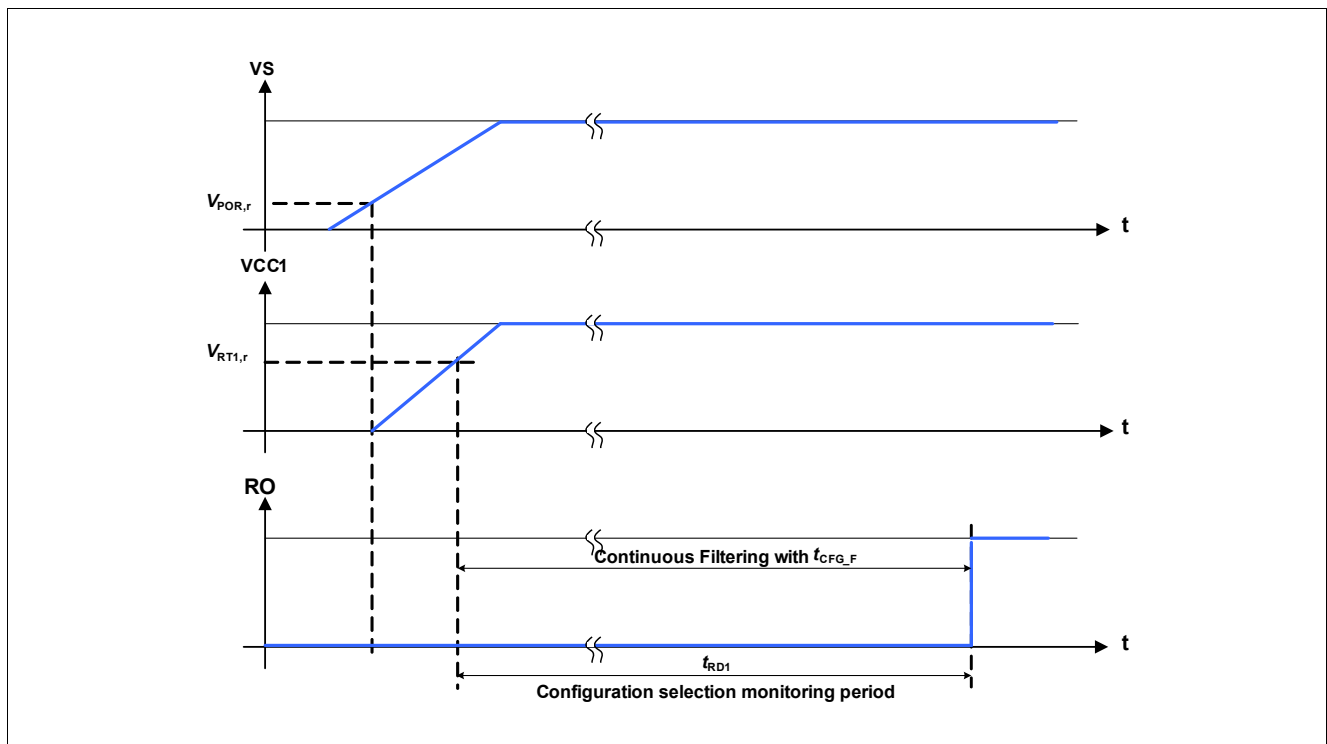

Figure 4 Hardware Configuration Selection Timing Diagram

There are four different device configurations (**Table 5**) available defining the watchdog failure and the VCC1 over voltage behavior. The configurations can be selected via the external connection on the INT pin and the SPI bit **CFG** in the **HW_CTRL** register (see also **Chapter 14.4**):

- **CFG**P = '1': Config 1 and Config 3:
 - A watchdog trigger failure leads to SBC Restart Mode and depending on **CFG** the Fail Outputs (FOx) are activated after the 1st (Config 1) or 2nd (Config 3) watchdog trigger failure;
 - A VCC1 over voltage detection will lead to SBC Restart Mode if **VCC1_OV_RST** is set. **VCC1_OV** will be set and the Fail Outputs are activated;
- **CFG**P = '0': Config 2 and Config 4:
 - A watchdog trigger failure leads to SBC Fail-Safe Mode and depending on **CFG** the Fail Outputs (FOx) are activated after the 1st (Config 2) or 2nd (Config 4) watchdog trigger failure. The first watchdog trigger failure in Config 4 will lead to SBC Restart Mode;
 - A VCC1 over voltage detection will lead to SBC Fail-Safe Mode if **VCC1_OV_RST** is set. **VCC1_OV** will be set and the Fail Outputs are activated;

The respective device configuration can be identified by reading the SPI bit **CFG** in the **HW_CTRL** register and the **CFG**P bit in the **WK_LVL_STAT** register.

Table 5 shows the configurations and the device behavior in case of a watchdog trigger failure:

Table 5 Watchdog Trigger Failure Configuration

| Config | INT Pin (CFG P) | SPI Bit CFG | Event | FOx Activation | SBC Mode Entry |
|--------|-------------------------|--------------------|----------------------|----------------------|--------------------|
| 1 | External pull-up | 1 | 1 x Watchdog Failure | after 1st WD Failure | SBC Restart Mode |
| 2 | No ext. pull-up | 1 | 1 x Watchdog Failure | after 1st WD Failure | SBC Fail-Safe Mode |
| 3 | External pull-up | 0 | 2 x Watchdog Failure | after 2nd WD Failure | SBC Restart Mode |
| 4 | No ext. pull-up | 0 | 2 x Watchdog Failure | after 2nd WD Failure | SBC Fail-Safe Mode |

Table 6 shows the configurations and the device behavior in case of a VCC1 over voltage detection when **VCC1_OV_RST** is set:

Table 6 Device Behavior in Case of VCC1 Over Voltage Detection

| Config | INT Pin (CFG P) | CFG Bit | VCC1_OV_RST | Event | VCC1_OV | FOx Activation | SBC Mode Entry |
|--------|-------------------------|----------------|--------------------|-------------|----------------|-------------------|--------------------|
| 1-4 | any value | x | 0 | 1 x VCC1 OV | 1 | no FOx activation | unchanged |
| 1 | External pull-up | 1 | 1 | 1 x VCC1 OV | 1 | after 1st VCC1 OV | SBC Restart Mode |
| 2 | No ext. pull-up | 1 | 1 | 1 x VCC1 OV | 1 | after 1st VCC1 OV | SBC Fail-Safe Mode |
| 3 | External pull-up | 0 | 1 | 1 x VCC1 OV | 1 | after 1st VCC1 OV | SBC Restart Mode |
| 4 | No ext. pull-up | 0 | 1 | 1 x VCC1 OV | 1 | after 1st VCC1 OV | SBC Fail-Safe Mode |

The respective configuration will be stored for all conditions and can only be changed by powering down the device ($V_S < V_{POR,f}$).

5.1.1.2 SBC Init Mode

In SBC Init Mode, the device waits for the microcontroller to finish its startup and initialization sequence. In the SBC Init Mode any valid SPI command will bring the SBC to SBC Normal Mode. During the long open window the watchdog has to be triggered. Thereby the watchdog will be automatically configured.

A missing watchdog trigger during the long open window will cause a watchdog failure and the device will enter SBC Restart Mode.

Wake events are ignored during SBC Init Mode and will therefore be lost.

Note: Any SPI command will bring the SBC to SBC Normal Mode even if it is a illegal SPI command (see [Chapter 14.2](#)).

Note: For a safe start-up, it is recommended to use the first SPI command to trigger and to configure the watchdog (see [Chapter 13.2](#)).

*Note: At power up no **VCC1_UV** will be issued nor will FOx be triggered as long as VCC1 is below the $V_{RT,x}$ threshold and if VS is below the VCC1 short circuit detection threshold $V_{s,uv}$. The RO pin will be kept low as long as VCC1 is below the selected $V_{RT,x}$ threshold.*

5.1.2 SBC Normal Mode

The SBC Normal Mode is the standard operating mode for the SBC. All configurations have to be done in SBC Normal Mode before entering a low-power mode (see also [Chapter 5.1.6](#) for the device configuration defining the Fail-Safe Mode behavior). A wake-up event on CAN and WKx will create an interrupt on pin INT - however, no change of the SBC mode will occur. The configuration options are listed below:

- VCC1 is active
- VCC2 can be switched ON or OFF (default = OFF)
- CAN is configurable (OFF coming from SBC Init Mode; OFF or wake capable coming from SBC Restart Mode, see also [Chapter 5.1.5](#))
- HS Outputs can be switched ON or OFF (default = OFF) or can be controlled by PWM; HS Outputs are OFF coming from SBC Restart Mode
- Wake pins show the input level and can be selected to be wake capable (interrupt)
- Cyclic sense can be configured with HS1...4 and Timer1 or Timer 2
- Cyclic wake can be configured with Timer1 or Timer2
- Watchdog is configurable
- All FOx outputs are OFF by default. Coming from SBC Restart Mode FOx can be active (due to a failure event, e.g. watchdog trigger failure, VCC1 short circuit, etc.) or inactive (no failure occurred)

In SBC Normal Mode, there is the possibility of testing the FO outputs, i.e. to verify if setting the FO pin to low will create the intended behavior within the system. The FO output can be enabled and then disabled again by the microcontroller by setting the [FO_ON](#) SPI bit. This feature is only intended for testing purposes.

5.1.3 SBC Stop Mode

The SBC Stop Mode is the first level technique to reduce the overall current consumption by setting the voltage regulators VCC1, VCC2 into a low-power mode. In this mode VCC1 is still active and supplying the microcontroller, which can enter a power down mode. The VCC2 supply, CAN mode as well as the HSx outputs can be configured to stay enabled. All kind of settings have to be done before entering SBC Stop Mode. In SBC Stop Mode any kind of SPI WRITE commands are ignored and the **SPI_FAIL** bit is set, except for changing to SBC Normal Mode, triggering a SBC Soft Reset, refreshing the watchdog as well as for reading and clearing the SPI status registers. A wake-up event on CAN and WKx will create an interrupt on pin INT - however, no change of the SBC mode will occur. The configuration options are listed below:

- VCC1 is ON
- VCC2 is fixed as configured in SBC Normal Mode
- CAN mode is fixed as configured in SBC Normal Mode
- WK pins are fixed as configured in SBC Normal Mode
- HS Outputs are fixed as configured in SBC Normal Mode
- Cyclic sense is fixed as configured in SBC Normal Mode
- Cyclic wake is fixed as configured in SBC Normal Mode
- Watchdog is fixed as configured in SBC Normal Mode
- SBC Soft Reset can be triggered
- FOx outputs are fixed, i.e. the state from SBC Normal Mode is maintained

An interrupt is triggered on the pin INT when SBC Stop Mode is entered and not all wake source signalization flags from **WK_STAT_1** and **WK_STAT_2** were cleared.

Note: If switches are enabled during SBC Stop Mode, e.g. HSx on with or without PWM, then the SBC current consumption will increase (see [Chapter 4.4](#)).

*Note: It is not possible to switch directly from SBC Stop Mode to SBC Sleep Mode. Doing so will also set the **SPI_FAIL** flag and will bring the SBC into Restart Mode.*

*Note: When WK1 and WK2 are configured for the alternate measurement function (**WK_MEAS** = 1) then the wake inputs cannot be selected as wake input sources.*

5.1.4 SBC Sleep Mode

The SBC Sleep Mode is the second level technique to reduce the overall current consumption to a minimum needed to react on wake-up events or for the SBC to perform autonomous actions (e.g. cyclic sense). In this mode, VCC1 is OFF and not supplying the microcontroller anymore. The VCC2 supply as well as the HSx outputs can be configured to stay enabled. The settings have to be done before entering SBC Sleep Mode. A wake-up event on CAN or WKx will bring the device via SBC Restart Mode into SBC Normal Mode again and signal the wake source. The configuration options are listed below:

- VCC1 is OFF
- VCC2 is fixed as configured in SBC Normal Mode
- CAN mode changes automatically from ON or Receive Only Mode to wake capable mode or can be selected to be OFF
- WK pins are fixed as configured in SBC Normal Mode
- HS Outputs are fixed as configured in SBC Normal Mode
- Cyclic sense is fixed as configured in SBC Normal Mode
- Cyclic wake is not available
- Watchdog is OFF
- FOx outputs are fixed, i.e. the state from SBC Normal Mode is maintained
- As VCC1 is OFF during SBC Sleep Mode, no SPI communication is possible;
- The Sleep Mode entry is signalled in the SPI register **DEV_STAT** with the bit **DEV_STAT**

It is not possible to switch all wake sources off in SBC Sleep Mode. Doing so will set the **SPI_FAIL** flag and will bring the SBC into SBC Restart Mode.

In order to enter SBC Sleep Mode successfully, all wake source signalization flags from **WK_STAT_1** and **WK_STAT_2** need to be cleared. A failure to do so will result in an immediate wake-up from SBC Sleep Mode by going via SBC Restart to Normal Mode.

All settings must be done before entering SBC Sleep Mode.

Note: If switches are enabled during SBC Sleep mode, e.g. HSx on with or without PWM, then the SBC current consumption will increase (see [Chapter 4.4](#)).

Note: Cyclic Sense function will not work properly anymore in case of an overcurrent, over temperature, under- or overvoltage (in case function is selected) event because the respective HS switch will be disabled.

*Note: When WK1 and WK2 are configured for the alternate measurement function (**WK_MEAS** = 1) then the wake inputs cannot be selected as wake input sources.*

5.1.5 SBC Restart Mode

There are multiple reasons to enter the SBC Restart Mode. The purpose of the SBC Restart Mode is to reset the microcontroller:

- in case of under voltage on VCC1 in SBC Normal and in SBC Stop Mode,
- in case of over voltage on VCC1 if the bit **VCC1_OV_RST** is set and if **CFGFP** = '1',
- due to 1st incorrect Watchdog triggering (only if Config1, Config3 or Config 4 is selected, otherwise SBC Fail-Safe Mode is immediately entered),
- In case of a wake event from SBC Sleep or SBC Fail-Safe Mode or a release of over temperature shutdown (TSD2) out of SBC Fail-Safe Mode this transition is used to ramp up VCC1 after a wake in a defined way.

From SBC Restart Mode, the SBC goes automatically to SBC Normal Mode, i.e the mode is left automatically by the SBC without any microcontroller influence. The SBC **MODE** bits are cleared. As shown in **Figure 35** the Reset Output (RO) is pulled low when entering Restart Mode and is released at the transition to Normal Mode after the reset delay time (t_{RD1}). The watchdog timer will start with a long open window starting from the moment of the rising edge of RO and the watchdog period setting in the register **WD_CTRL** will be changed to the respective default value '100'.

Leaving the SBC Restart Mode will not result in changing / deactivating the Fail outputs.

The behavior of the blocks is listed below:

- All FOx outputs are activated in case of a 1st watchdog trigger failure (if Config1 or Config2 is selected) or in case of VCC1 over voltage detection (if **VCC1_OV_RST** is set)
- VCC1 is ON or ramping up
- VCC2 will be disabled if it was activated before
- CAN is "woken" due to a wake event or OFF depending on previous SBC and transceiver mode (see also **Chapter 9**). It is wake capable when it was in CAN Normal-, Receive Only or wake capable mode before SBC Restart Mode
- HS Outputs will be disabled if they were activated before
- RO is pulled low during SBC Restart Mode
- SPI communication is ignored by the SBC, i.e. it is not interpreted
- The Restart Mode entry is signalled in the SPI register **DEV_STAT** with the bits **DEV_STAT**

Table 7 Reasons for Restart - State of SPI Status Bits after Return to Normal Mode

| Prev. SBC Mode | Event | DEV_STAT | WD_FAIL | VCC1_UV | VCC1_OV | VCC1_SC |
|----------------|--------------------------|----------|--|---------|---------|---------|
| Normal | 1x Watchdog Failure | 01 | 01 | x | x | x |
| Normal | 2x Watchdog Failure | 01 | 10 | x | x | x |
| Normal | VCC1 under voltage reset | 01 | xx | 1 | x | x |
| Normal | VCC1 over voltage reset | 01 | xx | x | 1 | x |
| Stop | 1x Watchdog Failure | 01 | 01 | x | x | x |
| Stop | 2x Watchdog Failure | 01 | 10 | x | x | x |
| Stop | VCC1 under voltage reset | 01 | xx | 1 | x | x |
| Stop | VCC1 over voltage reset | 01 | xx | x | 1 | x |
| Sleep | Wake-up event | 10 | xx | x | x | x |
| Fail-Safe | Wake-up event | 01 | see "Reasons for Fail Safe, Table 8 " | | | |

*Note: An over voltage event on VCC1 will only lead to SBC Restart Mode if the bit **VCC1_OV_RST** is set and if **CFGFP** = '1' (Config 1/3).*

*Note: The content of the **WD_FAIL** bits will depend on the device configuration, e.g. 1 or 2 watchdog failures.*

5.1.6 SBC Fail-Safe Mode

The purpose of this mode is to bring the system in a safe status after a failure condition by turning off the VCC1 supply and powering off the microcontroller. After a wake event the system is then able to restart again.

The Fail-Safe Mode is automatically reached for following events:

- after an SBC thermal shutdown (TSD2) (see also [Chapter 13.9.3](#)),
- in case of over voltage on VCC1 if the bit **VCC1_OV_RST** is set and if **CFGP** = '0',
- after a 1st incorrect watchdog trigger in Config2 (**CFG** = 1) and after a 2nd incorrect watchdog trigger in Config4 (**CFG** = 0) (see also [Chapter 5.1.1](#)),
- if VCC1 is shorted to GND (see also [Chapter 13.7](#)),
- After 4 consecutive VCC1 under voltage events (only if $V_S > V_{S,UV}$, see [Chapter 13.6](#)).

In this case, the default wake sources (CAN, WK1...3, see also registers **WK_CTRL_2**, **BUS_CTRL_1**) are activated, the wake events are cleared in the register **WK_STAT_1**, and all output drivers and all voltage regulators are switched off. When WK1 and WK2 are configured for the alternate measurement function (**WK_MEAS** = 1) then WK1 and WK2 will stay configured for the measurement function when SBC Fail-Safe Mode is entered, i.e. they will not be activated as wake sources.

The SBC Fail-Safe Mode will be maintained until a wake event on the default wake sources occurs. To avoid any fast toggling behavior a filter time of typ. 100ms ($t_{FS,min}$) is implemented. Wake events during this time will be stored and will automatically lead to entering SBC Restart Mode after the filter time.

In case of an VCC1 over temperature shutdown (TSD2) the SBC Restart Mode will be reached automatically after a filter time of typ. 1s (t_{TSD2}) without the need of a wake event.

Leaving the SBC Fail-Safe Mode will not result in deactivation of the Fail Output pins.

The following functions are influenced during SBC Fail-Safe Mode:

- All FOx outputs are activated (see also [Chapter 12](#))
- VCC1 is OFF
- VCC2 is OFF
- CAN is wake capable
- HS Outputs are OFF
- WK pins are wake capable through static sense (with default 16 μ s filter time)
- Cyclic sense and Cyclic wake is disabled
- SPI communication is disabled because VCC1 is OFF
- The Fail-Safe Mode activation is signalled in the SPI register **DEV_STAT** with the bits **FAILURE** and **DEV_STAT**

Table 8 Reasons for Fail-Safe - State of SPI Status Bits after Return to Normal Mode

| Prev. SBC Mode | Failure Event | DEV_STAT | TSD2 | WD_FAIL | VCC1_UV | VCC1_UV_FS | VCC1_OV | VCC1_SC |
|----------------|----------------------|----------|------|---------|---------|------------|---------|---------|
| Normal | 1 x Watchdog Failure | 01 | x | 01 | x | x | x | x |
| Normal | 2 x Watchdog Failure | 01 | x | 10 | x | x | x | x |
| Normal | TSD2 | 01 | 1 | xx | x | x | x | x |
| Normal | VCC1 short to GND | 01 | x | xx | 1 | x | x | 1 |
| Normal | 4x VCC1 UV | 01 | x | xx | 1 | 1 | x | x |
| Normal | VCC1 over voltage | 01 | x | xx | x | x | 1 | x |
| Stop | 1 x Watchdog Failure | 01 | x | 01 | x | x | x | x |
| Stop | 2 x Watchdog Failure | 01 | x | 10 | x | x | x | x |
| Stop | TSD2 | 01 | 1 | xx | x | x | x | x |
| Stop | VCC1 short to GND | 01 | x | xx | 1 | x | x | 1 |
| Stop | 4x VCC1 UV | 01 | x | xx | 1 | 1 | x | x |
| Stop | VCC1 over voltage | 01 | x | xx | x | x | 1 | x |

Note: An over voltage event on VCC1 will only lead to SBC Fail-Safe Mode if the bit VCC1_OV_RST is set and if **CFGF** = '0' (Config 2/4).

Note: The content of the WD_FAIL bits will depend on the device configuration, e.g. 1 or 2 watchdog failures.

Note: See [Chapter 13.6.1](#) for detailed description of the 4x VCC1 under voltage behavior.

5.1.7 SBC Development Mode

The SBC Development Mode is used during the development phase of the module. It is especially useful for software development.

Compared to the default SBC user mode operation, this mode is a super set of the state machine. The device will start also in SBC Init Mode and it is possible to use all the SBC Modes and functions with following differences:

- Watchdog is stopped and does not need to be triggered. Therefore no reset is triggered due to watchdog failure
- SBC Fail-Safe and SBC Restart Mode are not reached due to watchdog failure but the other reasons to enter these modes are still valid
- CAN and VCC2 default value in SBC INIT MODE and entering SBC Normal Mode from SBC Init Mode is ON instead of OFF

The SBC Software Development Mode is reached automatically if the FO3/TEST pin is set and kept LOW during SBC Init Mode. The voltage level monitoring is started as soon as $V_S > V_{POR,f}$. The Software Development Mode is configured and maintained if SBC Init Mode is left by sending any SPI command while FO3/TEST is LOW. In case the FO3/TEST level will be HIGH for longer than t_{TEST} during the monitoring period then the SBC Development Mode is not reached .

The SBC will remain in this mode for all conditions and can only be left by powering down the device ($V_S < V_{POR,f}$).

5.2 Wake Features

Following wake sources are implemented in the device:

- Static Sense: WK inputs are permanently active (see [Chapter 10](#))
- Cyclic Sense: WK inputs only active during on-time of cyclic sense period (see below)
- Cyclic Wake: internal wake source controlled via internal timer (see below)
- CAN wake: Wake-up via CAN message (see [Chapter 9](#))

5.2.1 Cyclic Sense

The cyclic sense feature is intended to reduce the quiescent current of the device and the application. In the cyclic sense configuration, one or more high-side drivers are switched on periodically controlled by [TIMER1_CTRL](#) and [TIMER2_CTRL](#). The respective high-side drivers supply external circuitries e.g. switches and/or resistor arrays, which are connected to one or more wake inputs (see [Figure 5](#)). Any edge change of the WKx input signal during the on-time of the cyclic sense period causes a wake. Depending on the SBC mode, either the INT is pulled low (SBC Normal Mode and Stop Mode) or the SBC is woken enabling the VCC1 (after SBC Sleep and SBC Fail-Safe Mode).

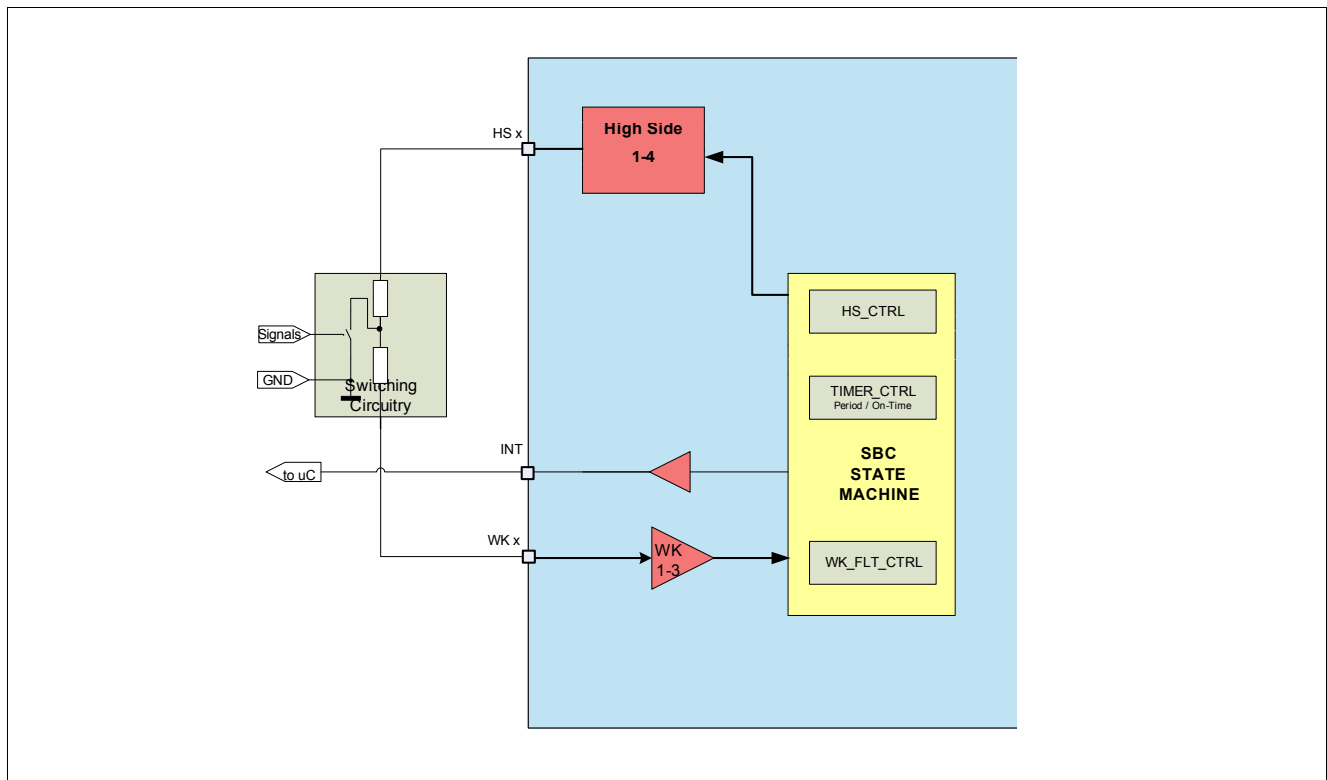

Figure 5 Cyclic Sense Working Principle

5.2.1.1 Configuration and Operation of Cyclic Sense

The correct sequence to configure the cyclic sense is shown in [Figure 6](#). All the configurations have to be performed before the on-time is set in the `TIMERx_CTRL` registers. The settings “OFF / LOW” and “OFF / HIGH” define the voltage level of the respective HS driver before the start of the cyclic sense. The intention of this selection is to avoid an unintentional wake due to a voltage level change at the start of the cyclic sense.

Cyclic Sense (=TimerX) will start as soon as the respective on-time has been selected independently from the assignment of the HS and filter configuration. The selection of the respective timer (Config C/D see [Chapter 10.2.1](#)) must therefore be done before starting the timer. The correct configuration sequence is as follows:

- Configure the initial level
- Mapping of a Timer to the respective HSx outputs
- Configuring the respective filter timing and WK pins
- Configuring the timer period and on-time

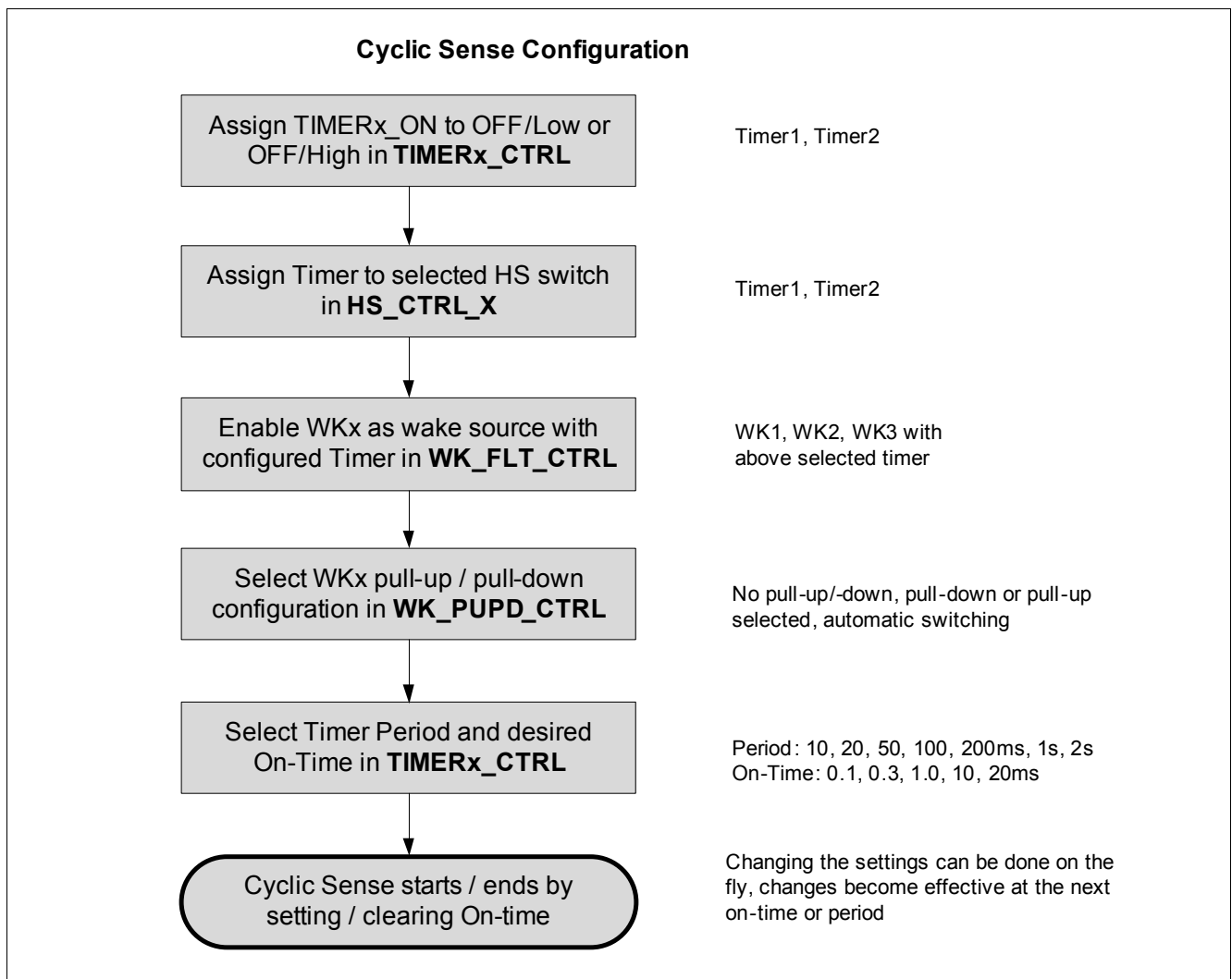

Figure 6 Cyclic Sense: Configuration and Sequence

Note: All configurations of period and on-time can be selected. However, recommended on-times for cyclic sense are 0.1ms, 0.3ms and 1ms. The SPI_FAIL will be set if the on-time is longer than the period.

System Features

The first sample of the WK input value (HIGH or LOW) is taken as the reference for the next cycle. A change of the WK input value between the first and second cycle recognized during the on-time of the second cycle will cause a wake from SBC Sleep Mode or an interrupt during SBC Normal or SBC Stop Mode.

A filter time of 16 μ s is implemented to avoid a parasitic wake-up due to transients or EMC disturbances. The filter time t_{FWK1} is triggered right at the end of the selected on-time and a wake signal is recognized if:

- the input level will not cross the switching threshold level of typ. 3V during the selected filter time (i.e. if the signal will keep the HIGH or LOW level) and
- there was an input level change between the current and previous cycle

A wake event due to cyclic sense in SBC Mode will set the respective bit WK1_WU, WK2_WU, or WK3_WU. During Cyclic Sense, WK_LVL_STAT is updated only with the sampled voltage levels of the WKx pins in SBC Normal or SBC Stop Mode.

The functionality of the sampling and different scenarios are depicted in Figure 7 to Figure 9. The behavior in SBC Stop and SBC Sleep Mode is identical except that in Stop Mode INT will be triggered to signal a change of WK input levels and in SBC Sleep Mode, VCC1 will power-up instead.

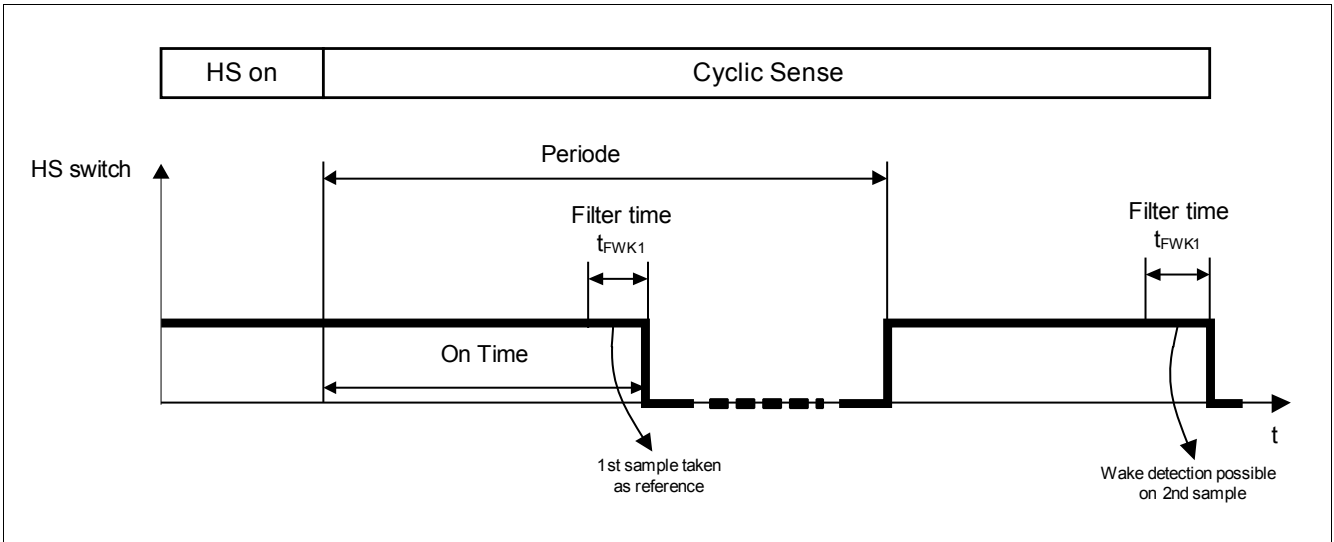

Figure 7 Wake Input Timing

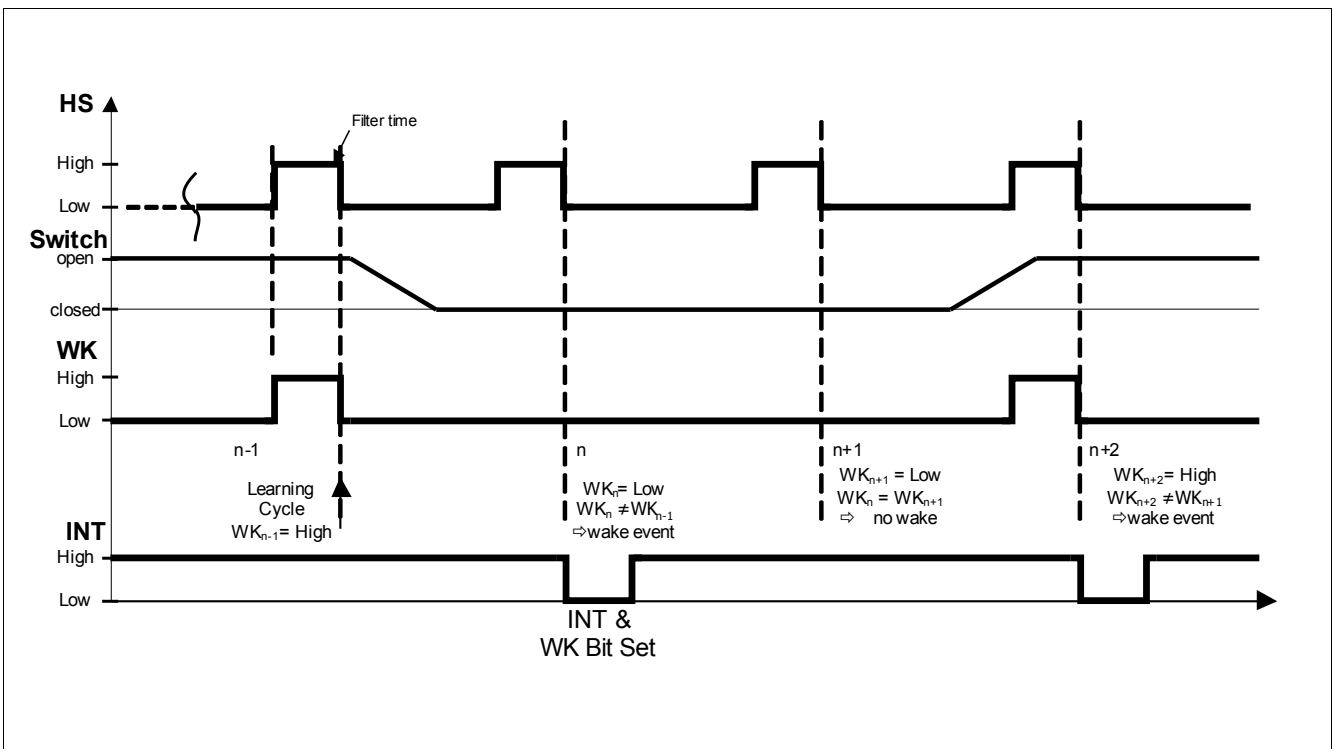

Figure 8 Cyclic Sense Example in SBC Stop Mode, HSx starts “OFF”/LOW, GND based WKx input

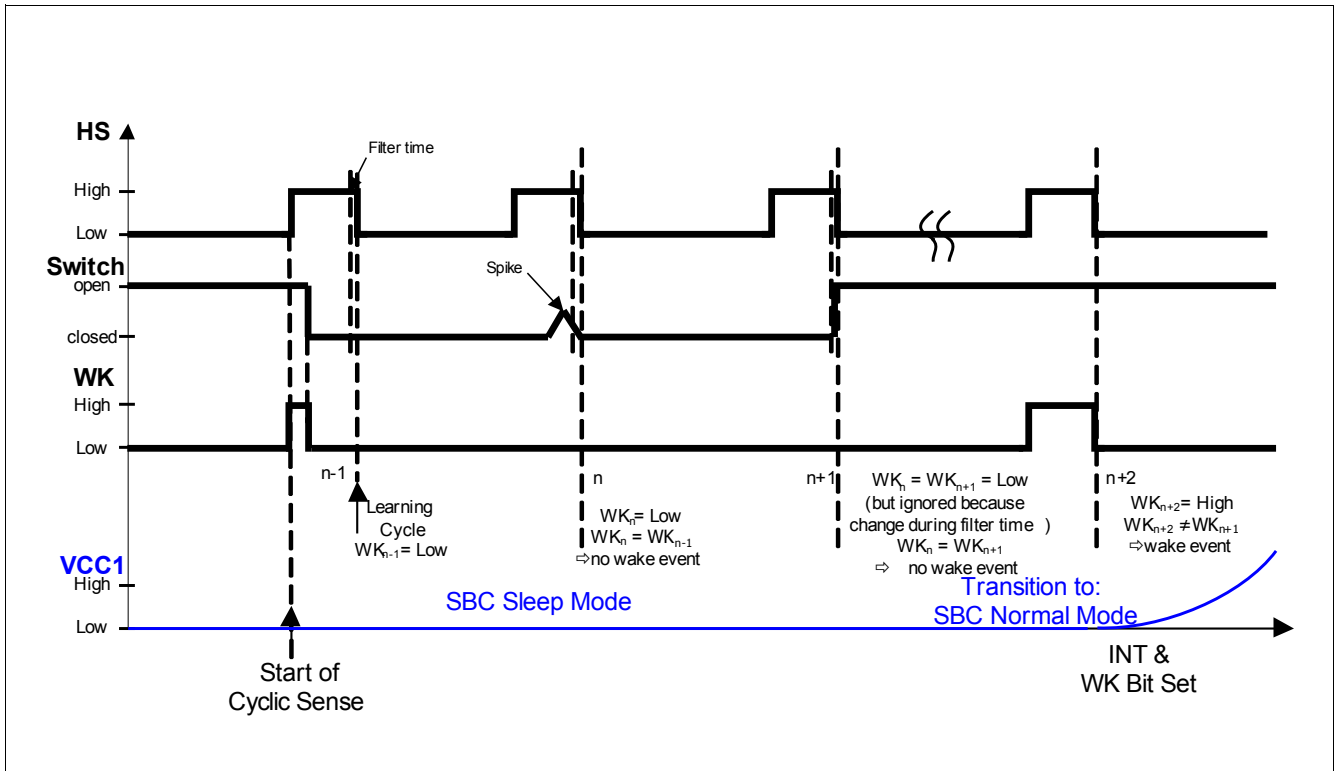

Figure 9 Cyclic Sense Example in SBC Sleep Mode, HSx starts “OFF”/HIGH, GND based WKx input

The cyclic sense function will not work properly anymore in case of following conditions:

- in case SBC Fail-Safe Mode is entered: The respective HS Switch will be disabled and the respective wake pin will be changed to static sensing
- In SBC Normal, Stop, or Sleep Mode in case of an overcurrent, overtemperature, under- or overvoltage (in case function is selected) event: the respective HS switch will be disabled

Note: The internal timers for cyclic sense are not disabled automatically in case the HS switch is turned off due to above mentioned failures. This must be considered to avoid loss of wake events.

5.2.1.2 Cyclic Sense in Low Power Mode

If cyclic sense is intended for SBC Stop or SBC Sleep Mode mode, it is necessary to activate the cyclic sense in SBC Normal Mode before going to the low power mode. A wake event due to cyclic sense will set the respective bit WK1_WU, WK2_WU or WK3_WU. In Stop Mode the wake event will trigger an interrupt, in Sleep Mode the wake event will send the device via Restart Mode to Normal Mode. Before returning to SBC Sleep Mode, the wake status register **WK_STAT_1** and **WK_STAT_2** needs to be cleared. Trying to go to SBC Sleep mode with uncleared wake flags, such as WKx_WU the SBC will directly wake-up from Sleep Mode by going via Restart Mode to Normal Mode, a reset is issued. The WKx_WU bit is seen as source for the wake. This is implemented in order not to lose a wake event during the transition.

5.2.2 Cyclic Wake

The cyclic wake feature is intended to reduce the quiescent current of the device and application.

For the cyclic wake feature one or both timers are configured as internal wake-up source and will periodically trigger an interrupt in SBC Normal and SBC Stop Mode.

The correct sequence to configure the cyclic wake is shown in **Figure 10**. The sequence is as follows:

- First, disable the timers to ensure that there is not unintentional interrupt when activating cyclic wake,
- Enable Timer1 and/or Timer2 as a wake-up source in the register **WK_CTRL_1**,
- Configure the respective period Timer1 and/or Timer2. Also an on-time (any value) must be selected to start the cyclic wake even if the value is ignored.

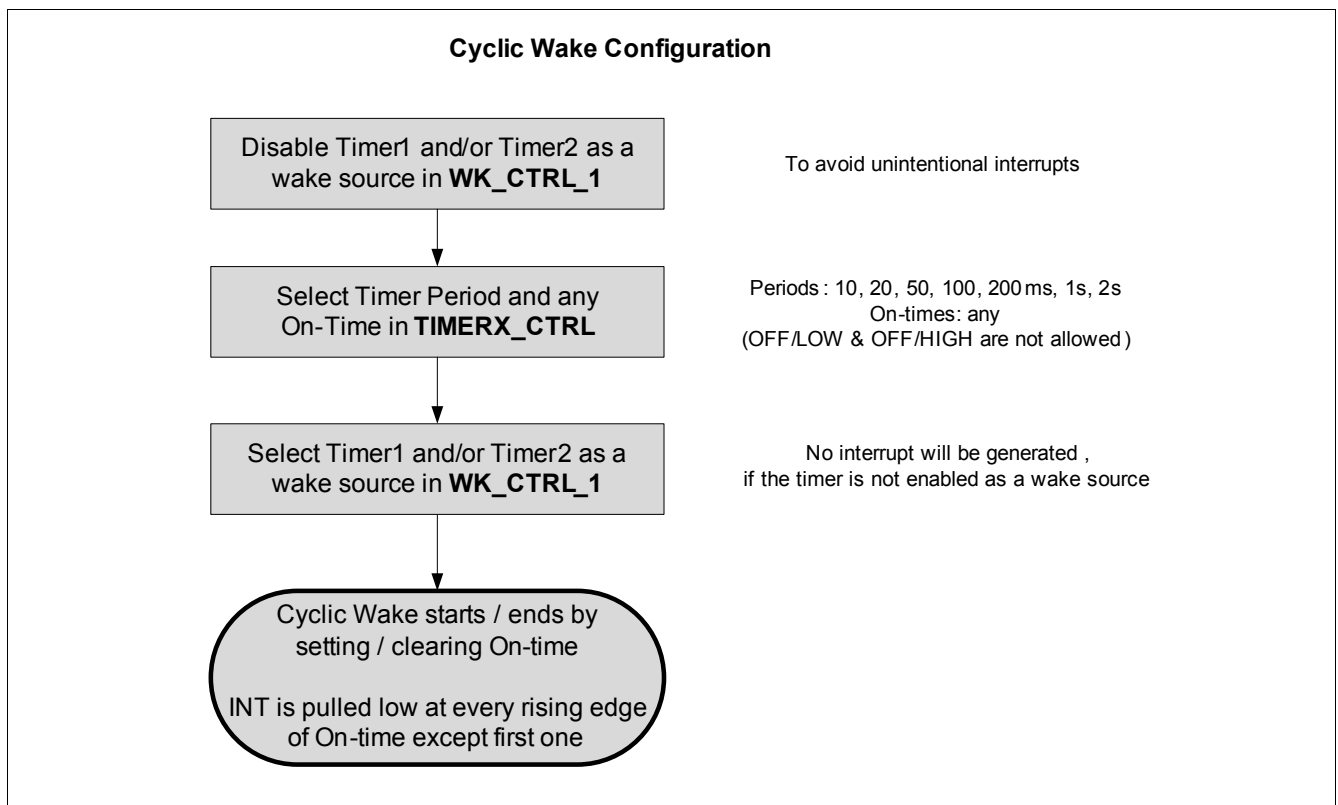

Figure 10 Cyclic Wake: Configuration and Sequence

As in cyclic sense, the cyclic wake function will start as soon as the on-time is configured. An interrupt is generated for every start of the on time except for the very first time when the timer is started

5.2.3 Internal Timer

The integrated Timer1 and Timer2 are typically used to wake up the microcontroller periodically (cyclic wake) or to perform cyclic sense on the wake inputs. Therefore, the timers can be mapped to the dedicated HS switches by SPI (via [HS_CTRL1...2](#)).

Following periods and on-times can be selected via the register [TIMER1_CTRL](#) and [TIMER2_CTRL](#) respectively:

- Period: 10ms / 20ms / 50ms / 100ms / 200ms / 1s / 2s
- On time: 0.1ms / 0.3ms / 1.0ms / 10ms / 20ms / OFF at HIGH or LOW

5.3 Supervision Features

The device offers various supervision features to support functional safety requirements. Please see [Chapter 13](#) for more information.

6 Voltage Regulator 1

6.1 Block Description

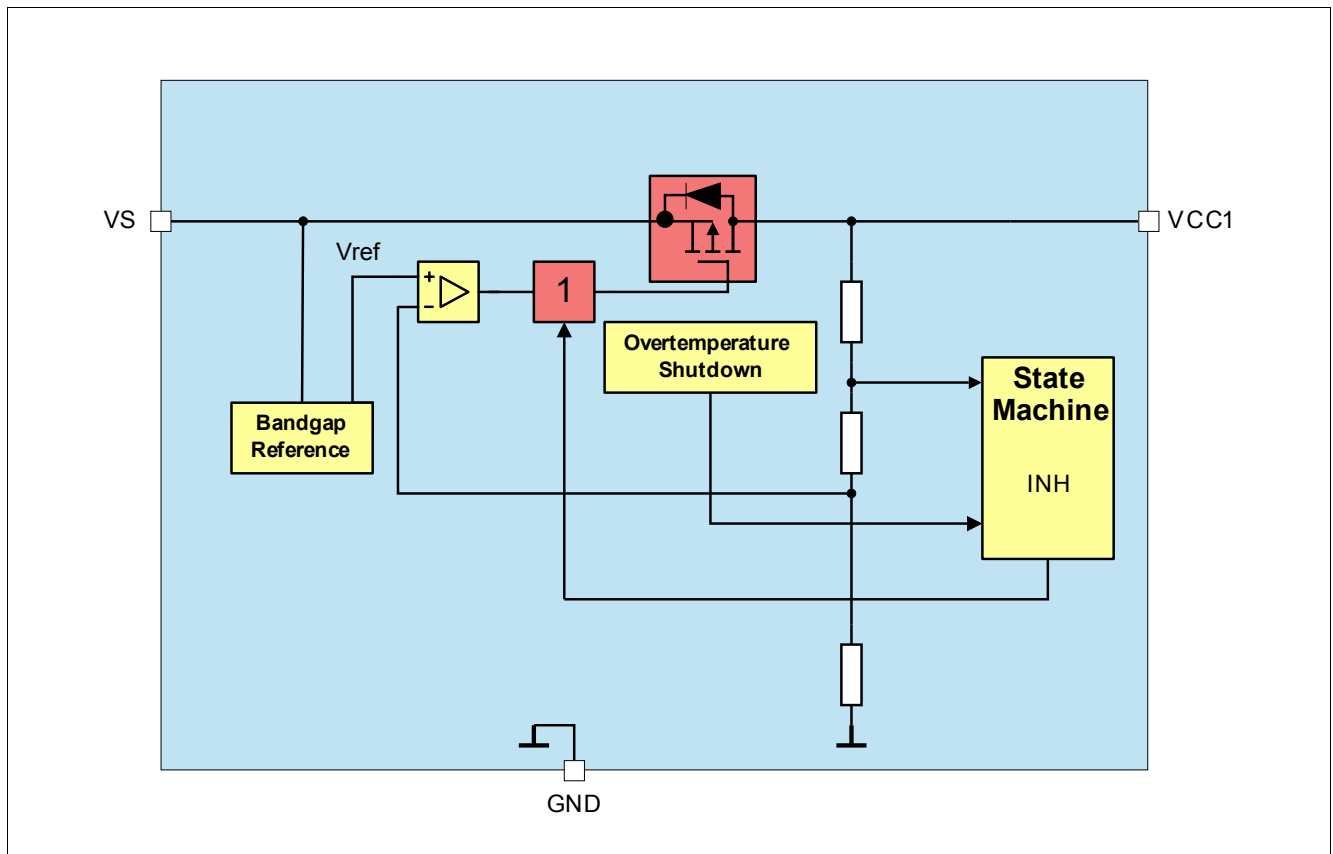

Figure 11 Module Block Diagram

Functional Features

- 5V low-drop voltage regulator
- Under voltage monitoring with adjustable reset level, VCC1 prewarning and VCC1 short circuit detection ($V_{RT1/2/3/4}$, $V_{PW,f}$). Please refer to [Chapter 13.6](#) and [Chapter 13.7](#) for more information.
- Short circuit detection and switch off with under voltage fail threshold, device enters SBC Fail-Safe Mode
- $\geq 470\text{nF}$ ceramic capacitor at voltage output for stability, with $\text{ESR} < 1\Omega @ f = 10\text{ kHz}$, to achieve the voltage regulator control loop stability based on the safe phase margin (bode diagram).
- Output current capability up to $I_{VCC1,lim}$.

6.2 Functional Description

The Voltage Regulator 1 (=VCC1) is “ON” in SBC Normal and SBC Stop Mode and is disabled in SBC Sleep and in SBC Fail-Safe Mode. The regulator can provide an output current up to $I_{VCC1,lim}$.

For low-quiescent current reasons, the output voltage tolerance is decreased in SBC Stop Mode because only a low-power mode regulator with a lower accuracy ($V_{CC1,out41}$) will be active for small loads. If the load current on VCC1 exceeds the selected threshold ($I_{VCC1,lpeak1,r}$ or $I_{VCC1,lpeak2,r}$) then the high-power mode regulator will be also activated to support an optimum dynamic load behavior. The current consumption will then increase by typ. 2.9mA. If the load current on VCC1 falls below the selected threshold ($I_{VCC1,lpeak1,f}$ or $I_{VCC1,lpeak2,f}$), then the low-quiescent current mode is resumed again by disabling the high-power mode regulator.

Both regulators (low-power mode and high-power mode) are active in SBC Normal Mode.

Two different active peak thresholds can be selected via SPI:

- **I_PEAK_TH = '0'**(default): the lower VCC1 active peak threshold 1 is selected with lowest quiescent current consumption in SBC Stop Mode ($I_{Stop_1,25}$, $I_{Stop_1,85}$);
- **I_PEAK_TH = '1'**: the higher VCC1 active peak threshold 2 is selected with an increased quiescent current consumption in SBC Stop Mode ($I_{Stop_2,25}$, $I_{Stop_2,85}$);

6.3 Electrical Characteristics

Table 9 Electrical Characteristics

$V_S = 5.5\text{ V to }28\text{ V}$; $T_j = -40\text{ °C to }+150\text{ °C}$; all voltages with respect to ground, positive current flowing into pin (unless otherwise specified)

| Parameter | Symbol | Values | | | Unit | Note / Test Condition | Number |
|---|---------------------|--------|------|--------------------|------|--|----------|
| | | Min. | Typ. | Max. | | | |
| Output Voltage including line and Load regulation | $V_{CC1,out1}$ | 4.9 | 5.0 | 5.1 | V | ¹⁾ SBC Normal Mode; $10\mu\text{A} < I_{VCC1} < 250\text{mA}$ $6\text{V} < V_S < 28\text{V}$ | P_6.3.1 |
| Output Voltage including line and Load regulation | $V_{CC1,out2}$ | 4.9 | 5.0 | 5.1 | V | ¹⁾ SBC Normal Mode; $10\mu\text{A} < I_{VCC1} < 150\text{mA}$ | P_6.3.7 |
| Output Voltage including line and Load regulation | $V_{CC1,out3}$ | 4.97 | – | 5.07 | V | ¹⁾²⁾ SBC Normal Mode; $20\text{mA} < I_{VCC1} < 90\text{mA}$ $8\text{V} < V_S < 18\text{V}$ $25\text{°C} < T_j < 125\text{°C}$ | P_6.3.12 |
| Output Voltage including line and Load regulation | $V_{CC1,out41}$ | 4.9 | 5.05 | 5.2 | V | SBC Stop Mode; $1\text{mA} < I_{VCC1} < I_{VCC1,lpeak}$ | P_6.3.2 |
| Output Voltage including line and Load regulation | $V_{CC1,out42}$ | 4.9 | 5.05 | 5.25 | V | SBC Stop Mode; $10\mu\text{A} < I_{VCC1} < 1\text{mA}$ | P_6.3.20 |
| Output Drop | $V_{CC1,d1}$ | – | – | 500 | mV | $I_{VCC1} = 50\text{mA}$ $V_S = 3\text{V}$ | P_6.3.3 |
| Output Drop | $V_{CC1,d2}$ | – | – | 500 | mV | $I_{VCC1} = 150\text{mA}$ $V_S = 5\text{V}$ | P_6.3.4 |
| VCC1 Active Peak Threshold 1 (Transition threshold between low-power and high-power mode regulator) | $I_{VCC1,lpeak1,r}$ | – | 1.9 | 3.5 | mA | ²⁾ I_{CC1} rising; $V_S = 13.5\text{V}$ $-40\text{°C} < T_j < 150\text{°C}$; I_PEAK_TH = '0' | P_6.3.13 |
| VCC1 Active Peak Threshold 1 (Transition threshold between high-power and low-power mode regulator) | $I_{VCC1,lpeak1,f}$ | 0.5 | 1.3 | – | mA | ²⁾ I_{CC1} falling; $V_S = 13.5\text{V}$ $-40\text{°C} < T_j < 150\text{°C}$; I_PEAK_TH = '0' | P_6.3.17 |
| VCC1 Active Peak Threshold 2 (Transition threshold between low-power and high-power mode regulator) | $I_{VCC1,lpeak2,r}$ | – | 4.3 | 7.0 | mA | ²⁾ I_{CC1} rising; $V_S = 13.5\text{V}$ $-40\text{°C} < T_j < 150\text{°C}$; I_PEAK_TH = '1' | P_6.3.18 |
| VCC1 Active Peak Threshold 2 (Transition threshold between high-power and low-power mode regulator) | $I_{VCC1,lpeak2,f}$ | 1.7 | 3.4 | – | mA | ²⁾ I_{CC1} falling; $V_S = 13.5\text{V}$ $-40\text{°C} < T_j < 150\text{°C}$; I_PEAK_TH = '1' | P_6.3.19 |
| Over Current Limitation | $I_{VCC1,lim}$ | 250 | – | 1200 ²⁾ | mA | current flowing out of pin, $V_{CC1} = 0\text{V}$ | P_6.3.6 |

1) In SBC Stop Mode, the specified output voltage tolerance applies when I_{VCC1} has exceeded the selected active peak threshold ($I_{VCC1,lpeak1,r}$ or $I_{VCC1,lpeak2,r}$) but with increased current consumption.

2) Not subject to production test, specified by design.

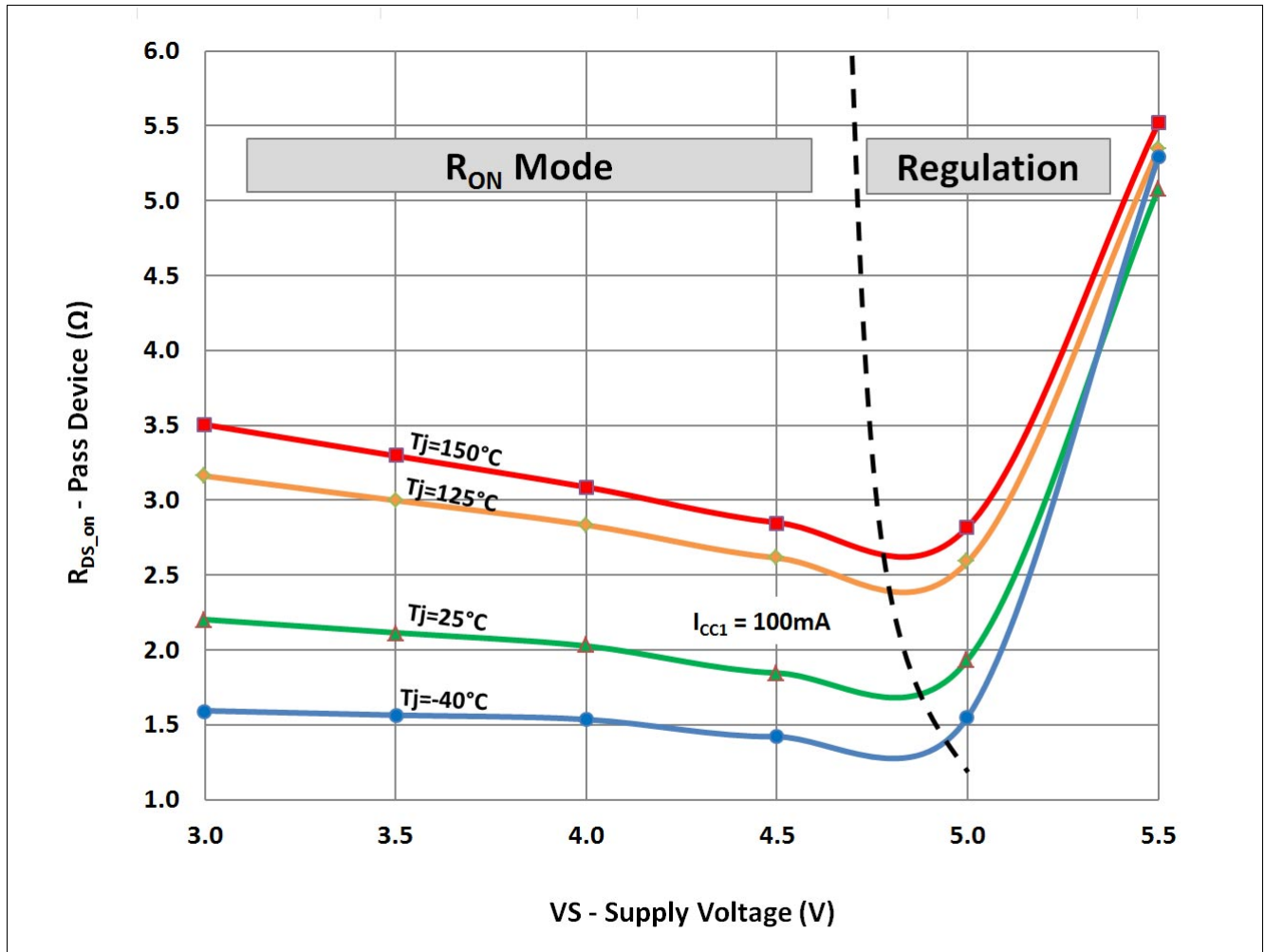

Figure 12 Typical on-resistance of VCC1 pass device during low drop operation for $I_{CC1} = 100\text{mA}$

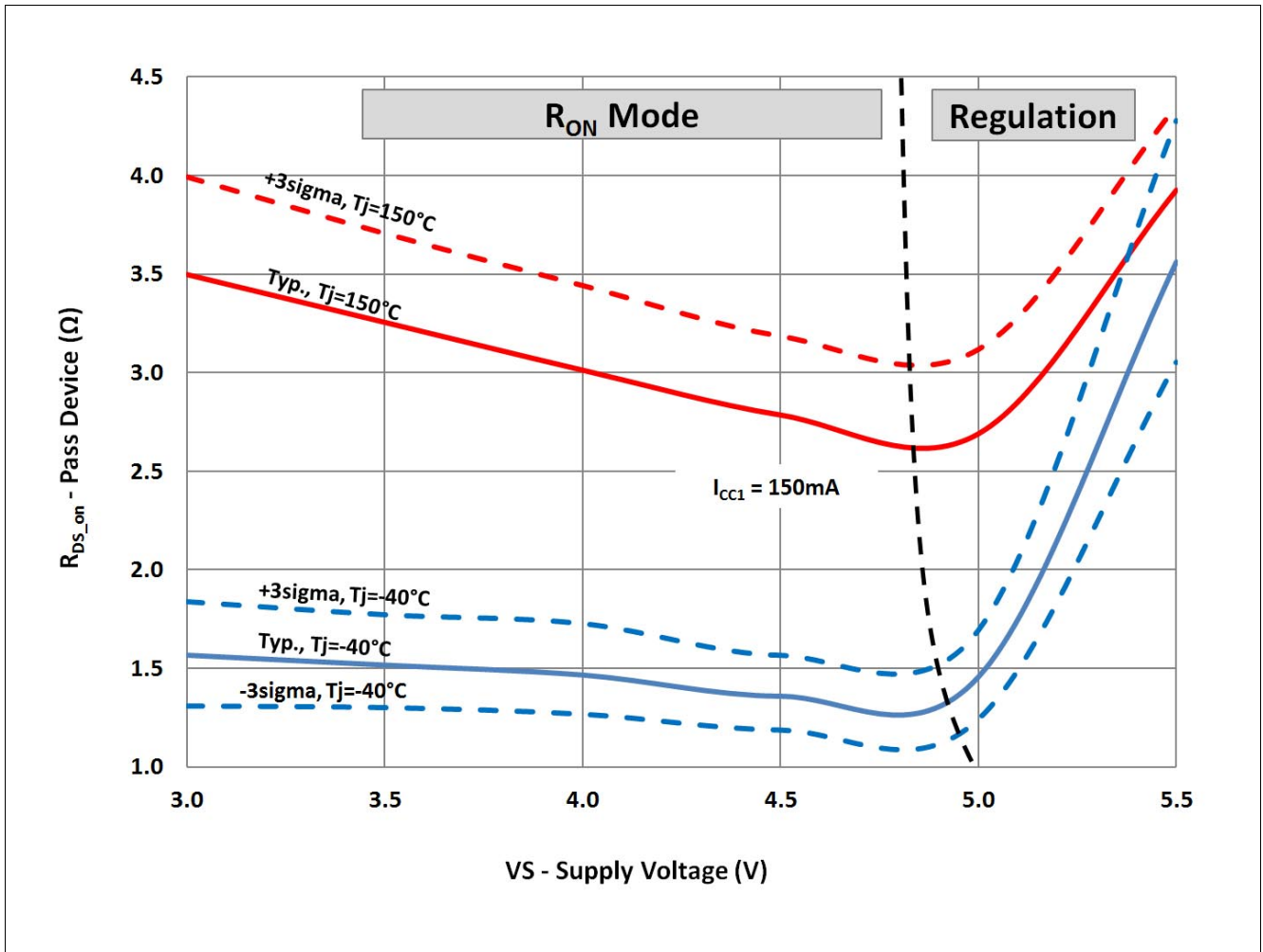

Figure 13 On-resistance range of VCC1 pass device during low drop operation for $I_{CC1} = 150\text{mA}$

7 Voltage Regulator 2

7.1 Block Description

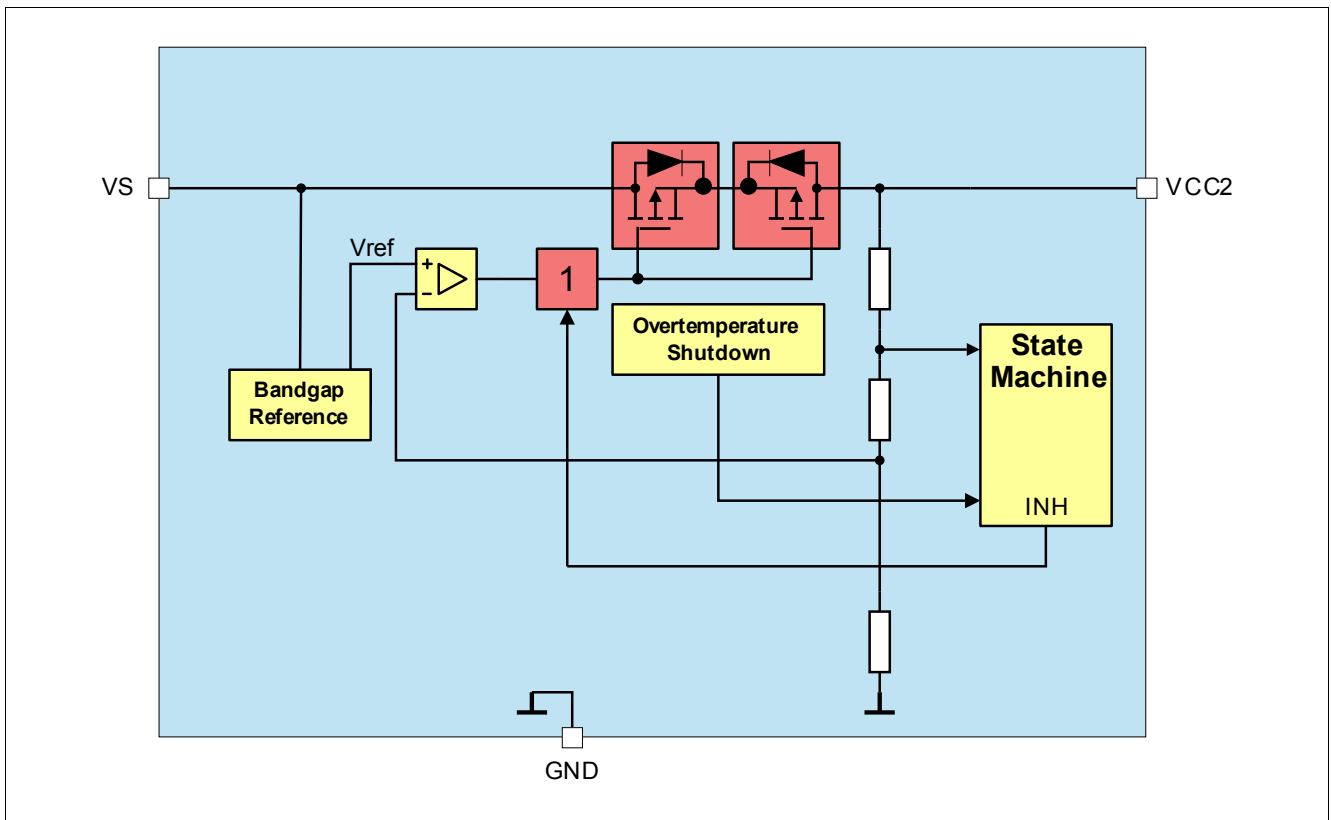

Figure 14 Module Block Diagram

Functional Features

- 5 V low-drop voltage regulator
- Protected against short to battery voltage, e.g. for off-board sensor supply
- Can also be used for CAN supply
- VCC2 under voltage monitoring. Please refer to [Chapter 13.8](#) for more information
- Can be active in SBC Normal, SBC Stop, and SBC Sleep Mode (not SBC Fail-Safe Mode)
- VCC2 switch off after entering SBC Restart Mode. Switch off is latched, LDO must be enabled via SPI after shutdown.
- Over temperature protection
- $\geq 470\text{nF}$ ceramic capacitor at output voltage for stability, with $\text{ESR} < 1\Omega @ f = 10 \text{ kHz}$, to achieve the voltage regulator control loop stability based on the safe phase margin (bode diagram).
- Output current capability up to $I_{\text{VCC2,lim}}$.

7.2 Functional Description

In SBC Normal Mode VCC2 can be switched on or off via SPI.

For SBC Stop- or Sleep Mode, the VCC2 has to be switched on or off before entering the respective SBC mode.

The regulator can provide an output current up to $I_{VCC2,lim}$.

For low-quiescent current reasons, the output voltage tolerance is decreased in SBC Stop Mode because only a low-power mode regulator with a lower accuracy ($V_{CC2,out5}$) will be active for small loads. If the load current on VCC2 exceeds $I_{VCC2} > I_{VCC2,peak,r}$ then the high-power mode regulator will also be enabled to support an optimum dynamic load behavior. The current consumption will then increase by typ. 2.9mA.

If the load current on VCC2 falls below the threshold ($I_{VCC2} < I_{VCC2,peak,r}$), then the low-quiescent current mode is resumed again by disabling the high-power mode regulator.

Both regulators are active in SBC Normal Mode.

Note: If the VCC2 output voltage is supplying external off-board loads, the application must consider the series resonance circuit built by cable inductance and decoupling capacitor at the load. Sufficient damping must be provided.

7.2.1 Short to Battery Protection

The output stage is protected for short to VBAT.

7.3 Electrical Characteristics
Table 10 Electrical Characteristics
 $V_S = 5.5\text{ V to }28\text{ V}$; $T_j = -40\text{ °C to }+150\text{ °C}$; all voltages with respect to ground, positive current flowing into pin (unless otherwise specified)

| Parameter | Symbol | Values | | | Unit | Note / Test Condition | Number |
|---|--------------------|--------|------|-------------------|------|---|----------|
| | | Min. | Typ. | Max. | | | |
| Output Voltage including line and Load regulation (SBC Normal Mode) | $V_{CC2,out1}$ | 4.9 | 5.0 | 5.1 | V | ¹⁾ SBC Normal Mode; $10\mu\text{A} < I_{VCC2} < 100\text{mA}$ $6.5\text{V} < V_S < 28\text{V}$ | P_7.3.1 |
| Output Voltage including line and Load regulation (SBC Normal Mode) | $V_{CC2,out2}$ | 4.9 | 5.0 | 5.1 | V | ¹⁾ SBC Normal Mode; $10\mu\text{A} < I_{VCC2} < 80\text{mA}$ $6\text{V} < V_S < 28\text{V}$ | P_7.3.16 |
| Output Voltage including line and Load regulation (SBC Normal Mode) | $V_{CC2,out3}$ | 4.9 | 5.0 | 5.1 | V | ¹⁾ SBC Normal Mode; $10\mu\text{A} < I_{VCC2} < 40\text{mA}$ | P_7.3.2 |
| Output Voltage including line and Load regulation (SBC Normal Mode) | $V_{CC2,out4}$ | 4.97 | – | 5.07 | V | ²⁾ SBC Normal Mode; $10\mu\text{A} < I_{VCC2} < 5\text{mA}$ $8\text{V} < V_S < 18\text{V}$ $25\text{°C} < T_j < 125\text{°C}$ | P_7.3.14 |
| Output Voltage including line and Load regulation (SBC Stop/Sleep Mode) | $V_{CC2,out5}$ | 4.9 | 5.05 | 5.2 | V | Stop, Sleep Mode; $1\text{mA} < I_{VCC2} < I_{VCC2,lpeak}$ | P_7.3.3 |
| Output Voltage including line and Load regulation (SBC Stop/Sleep Mode) | $V_{CC2,out6}$ | 4.9 | 5.05 | 5.25 | V | Stop, Sleep Mode; $10\mu\text{A} < I_{VCC2} < 1\text{mA}$ | P_7.3.18 |
| Output Drop | $V_{CC2,d1}$ | – | – | 500 | mV | $I_{VCC2} = 30\text{mA}$ $V_S = 5\text{V}$ | P_7.3.4 |
| VCC2 Active Peak Threshold (Transition threshold between low-power and high-power mode regulator) | $I_{VCC2,lpeak,r}$ | – | 1.9 | 3.5 | mA | ²⁾ I_{CC2} rising; $V_S = 13.5\text{V}$ $-40\text{°C} < T_j < 150\text{°C}$ | P_7.3.15 |
| VCC2 Active Peak Threshold (Transition threshold between high-power and low-power mode regulator) | $I_{VCC2,lpeak,f}$ | 0.5 | 1.3 | – | mA | ²⁾ I_{CC2} falling; $V_S = 13.5\text{V}$ $-40\text{°C} < T_j < 150\text{°C}$ | P_7.3.17 |
| Over Current limitation | $I_{VCC2,lim}$ | 100 | – | 750 ²⁾ | mA | current flowing out of pin, $V_{CC2} = 0\text{V}$ | P_7.3.5 |

1) In SBC Stop Mode, the specified output voltage tolerance applies when I_{VCC2} has exceeded the selected active peak threshold ($I_{VCC2,lpeak,r}$) but with increased current consumption.

2) Not subject to production test, specified by design.

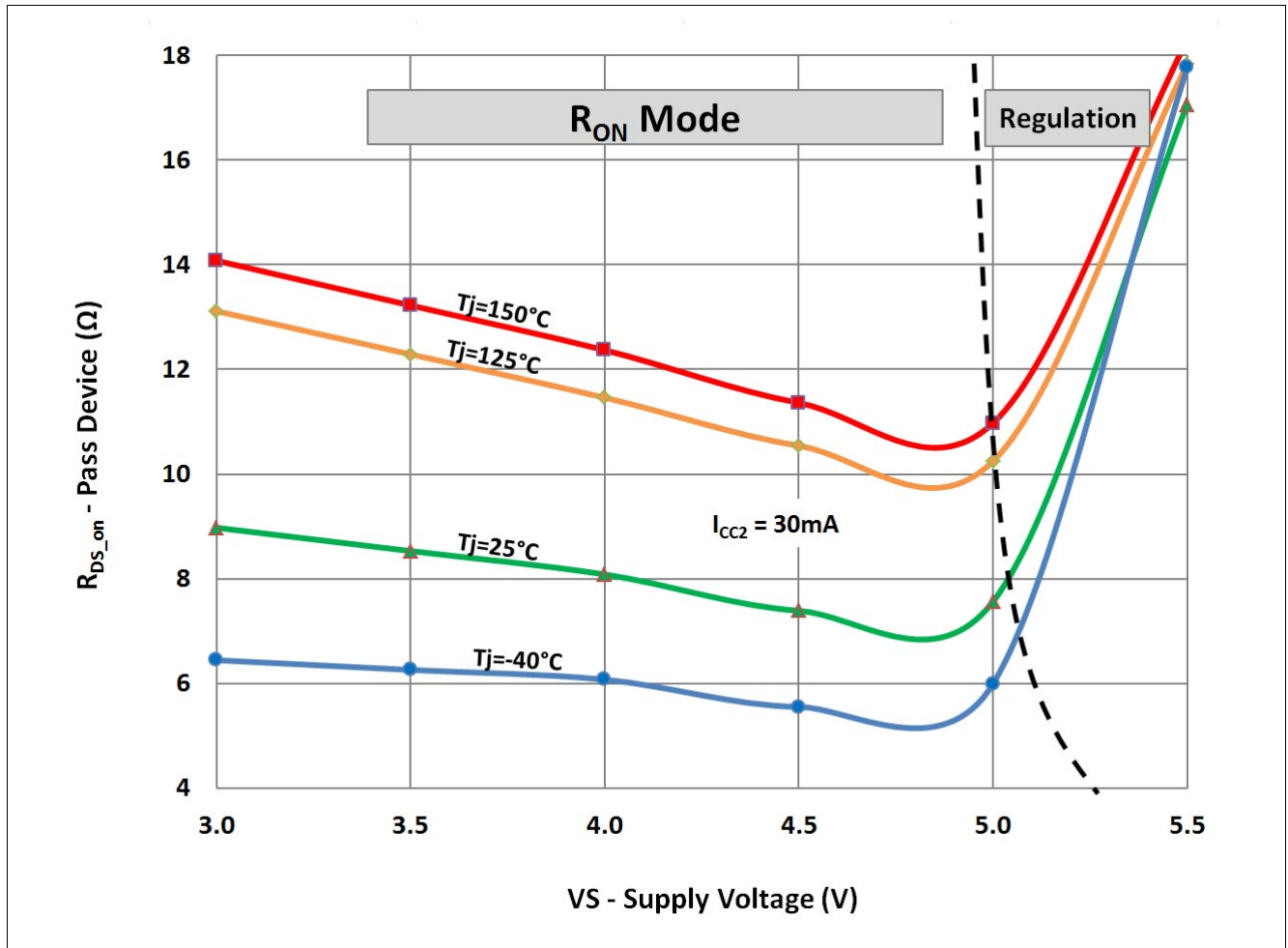

Figure 15 Typical on-resistance of VCC2 pass device during low drop operation for $I_{CC2} = 30\text{mA}$

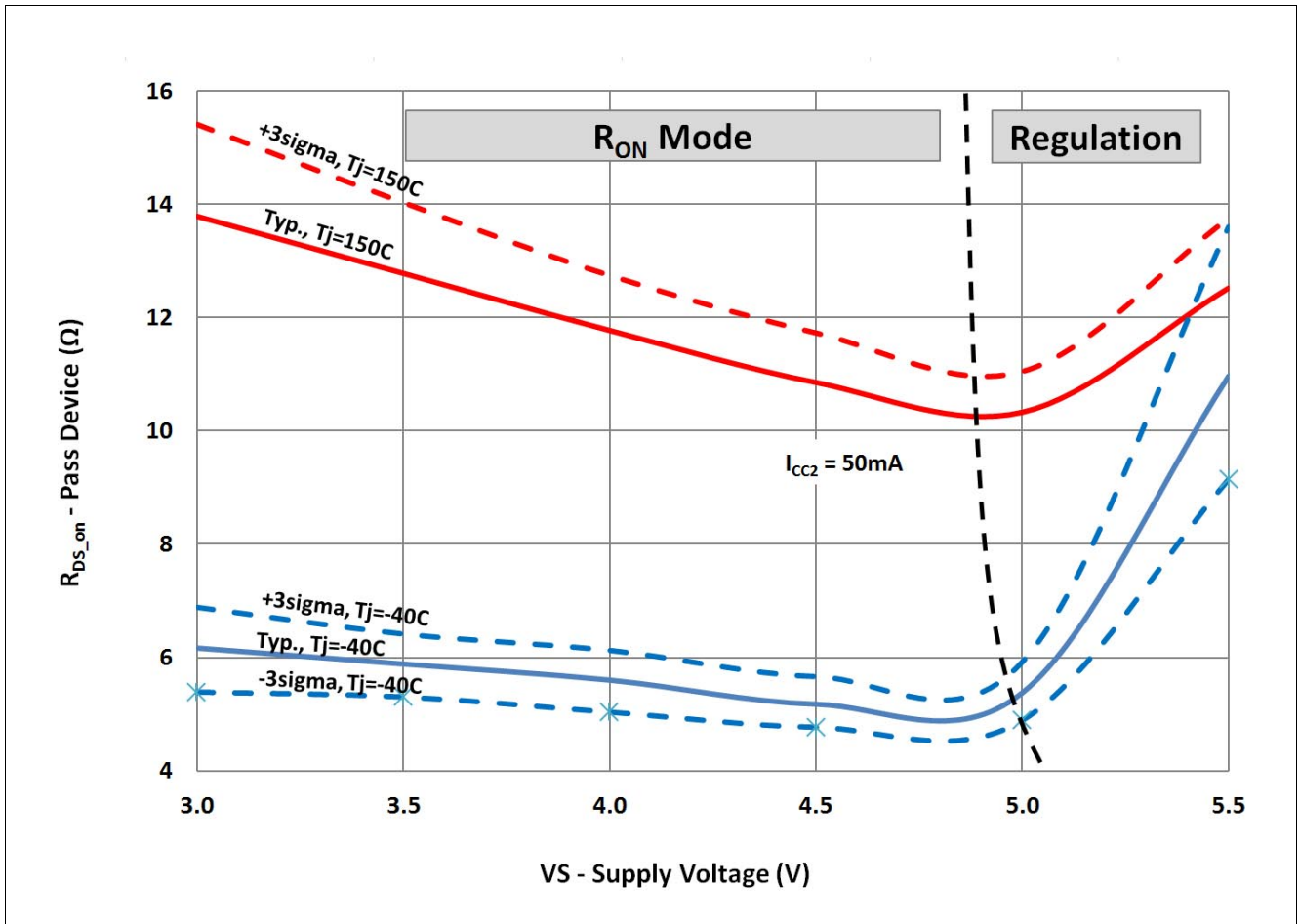

Figure 16 On-resistance range of VCC2 pass device during low drop operation for $I_{CC2} = 50\text{mA}$

8 High-Side Switch

8.1 Block Description

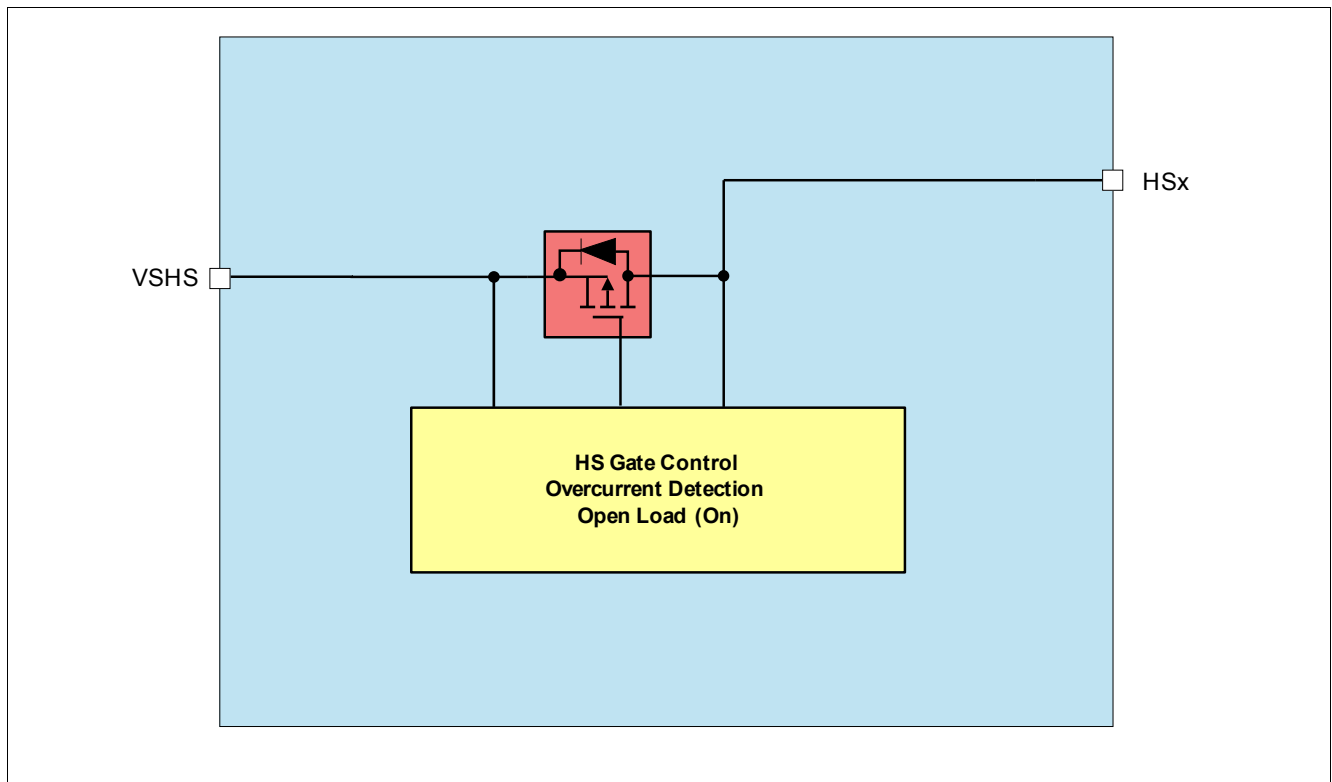

Figure 17 High-Side Module Block Diagram

Features

- Dedicated supply pin VSHS for high-side outputs
- Over voltage and under voltage switch off - configurable via SPI
- Overcurrent detection and switch off
- Open load detection in ON-state
- PWM capability with internal timer configurable via SPI
- Switch recovery after removal of OV or UV condition configurable via SPI

8.2 Functional Description

The High-Side switches can be used for control of LEDs, as supply for the wake inputs and for other loads. The High-Side outputs can be controlled either directly via SPI by ([HS_CTRL1](#), [HS_CTRL2](#)), by the integrated timers or by the integrated PWM generators.

The high-side outputs are supplied by a dedicated supply pin VSHS (different to VS). The topology supports improved cranking condition behavior.

The configuration of the High-Side (Permanent On, PWM, cyclic sense, etc.) drivers must be done in SBC Normal Mode. The configuration is taken over in SBC Stop- or SBC Sleep Mode and cannot be modified. When entering SBC Restart Mode or SBC Fail-Safe Mode the HSx outputs are disabled.

8.2.1 Over and Under Voltage Switch Off

All HS drivers in on-state are switched off in case of over voltage on VSHS ($V_{SHS,OVD}$). If the voltage drops below the over voltage threshold the HS drivers are activated again. The feature can be disabled by setting the SPI bit **HS_OV_SD_EN**.

The HS drivers are switched off in case of under voltage on VSHS ($V_{SHS,UVD}$). If the voltage rises above the under voltage threshold the HS drivers are activated again. The feature can be disabled by setting the SPI bit **HS_UV_SD_EN**.

So after release of under voltage or over voltage condition the HS switch goes back to programmed state in which it was configured via SPI. This behavior is only valid if the bit **HS_OV_UV_REC** is set to '1'. Otherwise the switches will stay off and the respective SPI control bits are cleared.

The over voltage and under voltage is signaled in the bits **VSHS_OV** and **VSHS_UV**, no other error bits are set.

8.2.2 Over Current Detection and Switch Off

If the load current exceeds the over current shutdown threshold for a time longer than the over current shutdown filter time the output is switched off.

The over current condition and the switch off is signaled with the respective HSx_OC_OT bit in the register **HS_OC_OT_STAT**. The HSx configuration is then reset to 000 by the SBC. To activate the High-Side again the HSx configuration has to be set to ON (001) or be programmed to a timer function. It is recommended to clear the over current bit before activation the High-Side switch, as the bits are not cleared automatically by the SBC.

8.2.3 Open Load Detection

Open load detection on the High-Side outputs is done during on state of the output. If the current in the activated output falls below then Open Load Detection current, the open load is detected and signaled via the respective bit HS1_OL, HS2_OL, HS3_OL, or HS4_OL in the register **HS_OL_STAT**. The High-Side output stays activated. If the open load condition disappears the Open Load bit in the SPI can be cleared. The bits are not cleared automatically by the SBC.

8.2.4 HSx Operation in Different SBC Modes

- During SBC Stop and SBC Sleep Mode the HSx outputs can be used for the cyclic sense feature. The open-load detection, over current shut down as well as over voltage and under voltage shutdown are available. The over current shutdown protection feature may influence the wake-up behavior¹⁾.
- the HSx output can also be enabled for SBC Stop and SBC Sleep Mode as well as controlled by the PWMx generator. The HSx outputs must be configured in SBC Normal Mode before entering a low-power mode.
- The HSx outputs are switched off during SBC Restart or SBC Fail-Safe Mode. They can be enabled via SPI if the failure condition is removed.

1) For the wake feature, the forced over current shut down case must be considered in the user software for all SBC Modes, i.e. due to disabled HSx switches a level change might not be detected anymore at WKx pins.

8.2.5 PWM and Timer Function

Two 8-bit PWM generators are dedicated to generate a PWM signal on the HS outputs, e.g. for brightness adjustment or compensation of supply voltage fluctuation. The PWM generators are mapped to the dedicated HS outputs, and the duty cycle can be independently configured with a 8bit resolution via SPI (**PWM1_CTRL**, **PWM2_CTRL**). Two different frequencies (200Hz, 400Hz) can be selected independently for every PWM generator in the register **PWM_FREQ_CTRL**.

PWM Assignment and Configuration:

- Configure duty cycle and frequency for respective PWM generator in **PWM1_CTRL/PWM2_CTRL** and **PWM_FREQ_CTRL**
- Assign PWM generator to respective HS switch(es) in **HSx_CTRL**
- The PWM generation will start right after the HSx is assigned to the PWM generator (**HS_CTRL1**, **HS_CTRL2**)

Assignment options of HS1... HS4

- Timer 1
- Timer 2
- PWM 1
- PWM 2

Note: The min. On-time during PWM is limited by the actual T_{on} and T_{off} time of the respective HS switch, e.g. the PWM setting '0000 0001' could not be realized.

In addition, the minimum PWM setting for reliable detection of over-current and open-load measurement is 4 digits for a period of 400Hz and 2 digits for a period of 200Hz

8.3 Electrical Characteristics

Table 11 Target Specifications

$V_S = 5.5\text{ V to }28\text{ V}$; $T_j = -40\text{ °C to }+150\text{ °C}$; all voltages with respect to ground, positive current flowing into pin (unless otherwise specified)

| Parameter | Symbol | Values | | | Unit | Note / Test Condition | Number |
|---|-----------------|--------|------|------|------------------|--|----------|
| | | Min. | Typ. | Max. | | | |
| Output HS1, HS2, HS3, HS4 | | | | | | | |
| Static Drain-Source ON Resistance HS1...HS4 | $R_{ON,HS25}$ | – | 7 | – | Ω | $I_{ds} = 60\text{mA}$, $T_j < 25\text{°C}$ | P_9.3.1 |
| Static Drain-Source ON Resistance HS1...HS4 | $R_{ON,HS150}$ | – | 11.5 | 16 | Ω | $I_{ds} = 60\text{mA}$, $T_j < 150\text{°C}$ | P_9.3.2 |
| Leakage Current HSx / per channel | $I_{leak,HS}$ | – | – | 2 | μA | ¹⁾ 0 V < VHSx < VSHS; $T_j < 85\text{°C}$ | P_9.3.11 |
| Output Slew Rate (rising) | $SR_{raise,HS}$ | 0.8 | – | 2.5 | V/ μs | ¹⁾ 20 to 80% $V_{SHS} = 6\text{ to }18\text{V}$ $R_L = 220\Omega$ | P_9.3.3 |
| Output Slew Rate (falling) | $SR_{fall,HS}$ | -2.5 | – | -0.8 | V/ μs | ¹⁾ 80 to 20% $V_{SHS} = 6\text{ to }18\text{V}$ $R_L = 220\Omega$ | P_9.3.4 |
| Switch-on time HSx | $t_{ON,HS}$ | 3 | – | 30 | μs | CSN = HIGH to 0.8*VSHS; $R_L = 220\Omega$; $V_{SHS} = 6\text{ to }18\text{V}$ | P_9.3.5 |
| Switch-off time HSx | $t_{OFF,HS}$ | 3 | – | 30 | μs | CSN = HIGH to 0.2*VSHS; $R_L = 220\Omega$; $V_{SHS} = 6\text{ to }18\text{V}$ | P_9.3.6 |
| Short Circuit Shutdown Current | $I_{SD,HS}$ | 150 | 245 | 300 | mA | $V_{SHS} = 6\text{ to }20\text{V}$, hysteresis included | P_9.3.7 |
| Short Circuit Shutdown Filter Time | $t_{SD,HS}$ | | 16 | | μs | ^{2), 3)} | P_9.3.8 |
| Open Load Detection Current | $I_{OL,HS}$ | 0.4 | – | 3 | mA | hysteresis included | P_9.3.9 |
| Open Load Detection hysteresis | $I_{OL,HS,hys}$ | – | 0.45 | – | mA | ¹⁾ | P_9.3.14 |
| Open Load Detection Filter Time | $t_{OL,HS}$ | – | 64 | – | μs | ^{2), 3)} | P_9.3.10 |

1) Not subject to production test, specified by design.

2) Not subject to production test, tolerance defined by internal oscillator tolerance.

3) The minimum PWM setting for reliable detection of over current and open load measurement is 5 digits for a period of 200Hz and 3 digits for a period of 150Hz.

9 High Speed CAN Transceiver

9.1 Block Description

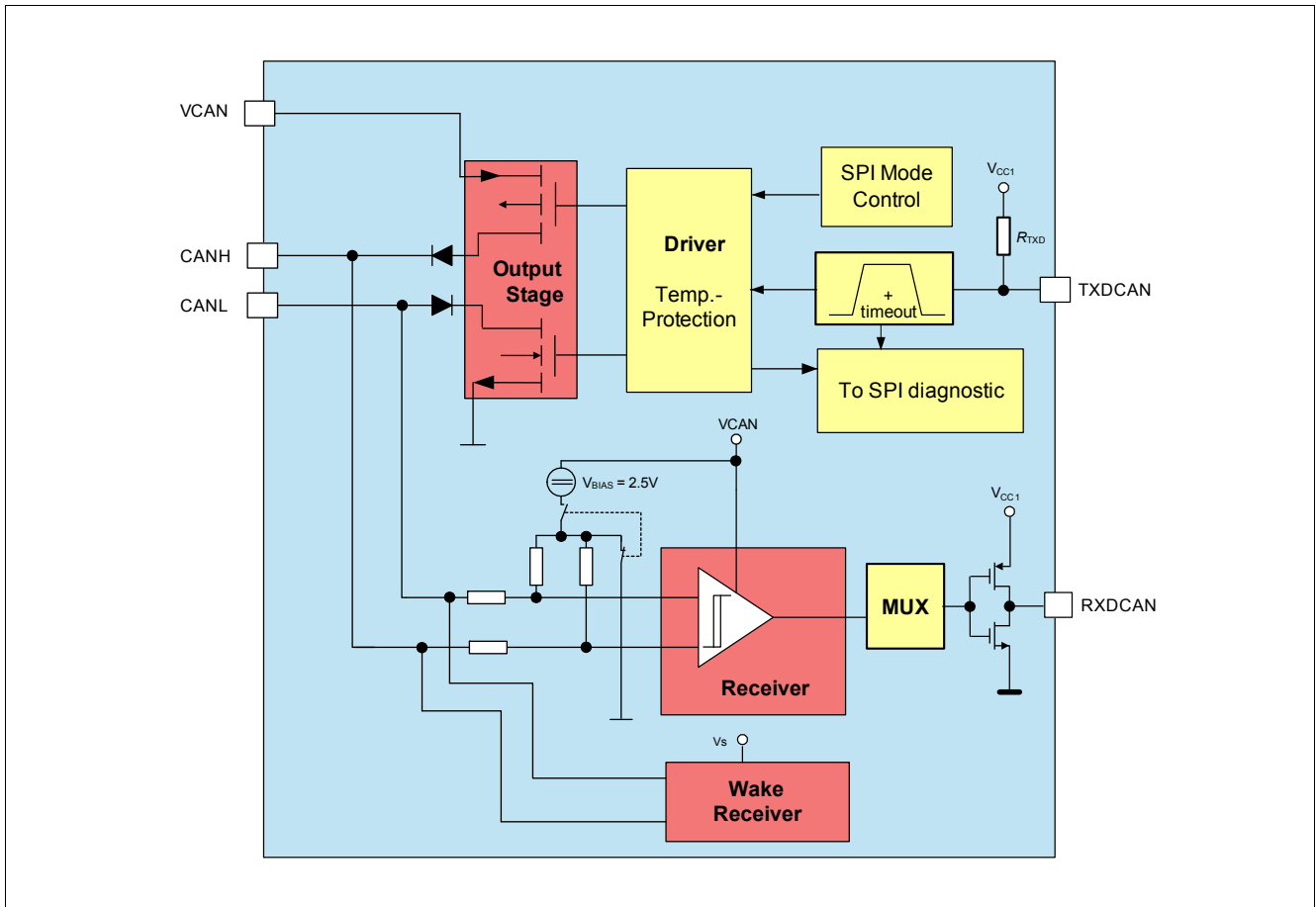

Figure 18 Functional Block Diagram

9.2 Functional Description

The Controller Area Network (CAN) transceiver part of the SBC provides high-speed (HS) differential mode data transmission (up to 2 Mbaud) and reception in automotive and industrial applications. It works as an interface between the CAN protocol controller and the physical bus lines compatible to ISO/DIS 11898-2, 11898-5 and SAE J2284.

The CAN transceiver offers low power modes to reduce current consumption. This supports networks with partially powered down nodes. To support software diagnostic functions, a CAN Receive-only Mode is implemented.

It is designed to provide excellent passive behavior when the transceiver is switched off (mixed networks, clamp15/30 applications).

A wake-up from the CAN wake capable mode is possible via a message on the bus. Thus, the microcontroller can be powered down or idled and will be woken up by the CAN bus activities.

The CAN transceiver is designed to withstand the severe conditions of automotive applications and to support 12 V applications.

The different transceiver modes can be controlled via the SPI CAN bits.

Figure 19 shows the possible transceiver mode transitions when changing the SBC mode.

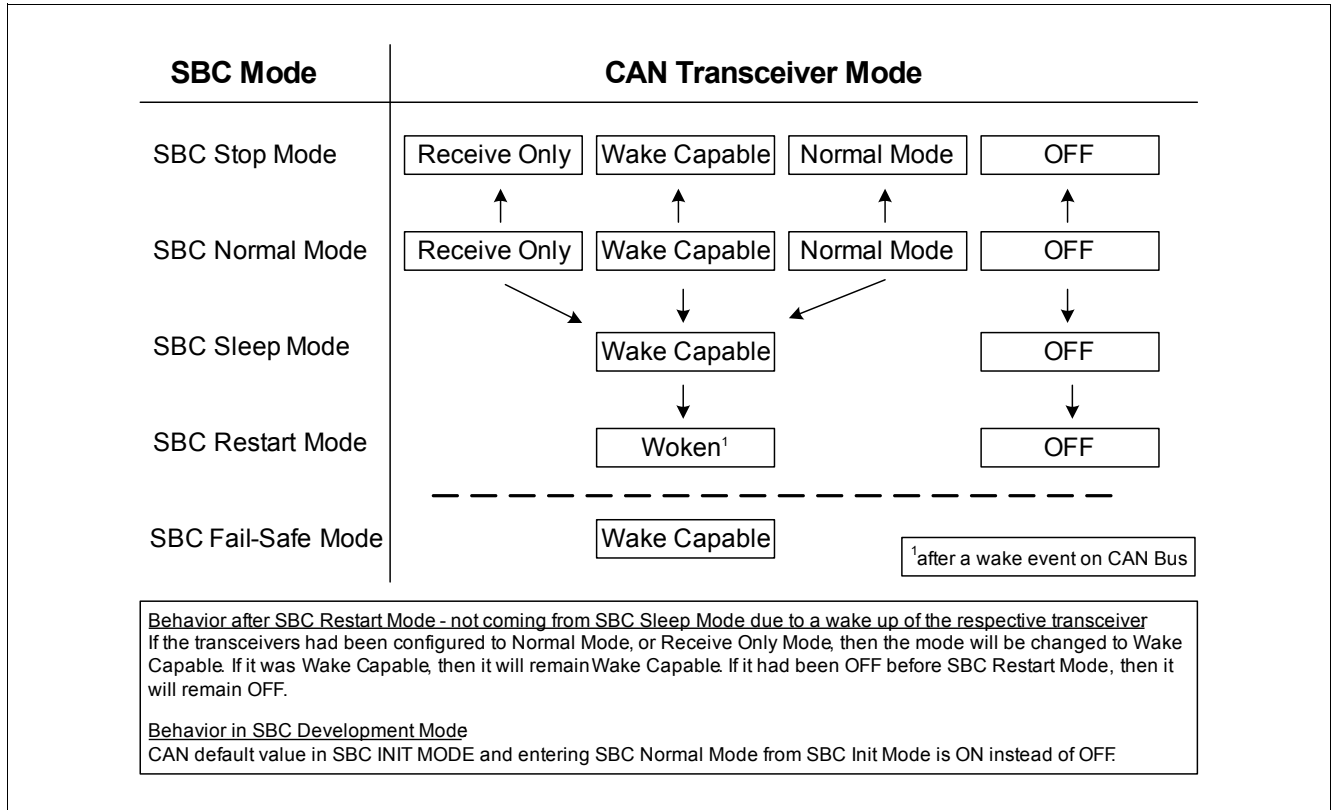

Figure 19 CAN Mode Control Diagram

CAN FD Support

CAN FD stands for 'CAN with Flexible Data Rate'. It is based on the well established CAN protocol as specified in ISO 11898-1. CAN FD still uses the CAN bus arbitration method. The benefit is that the bit rate can be increased by switching to a shorter bit time at the end of the arbitration process and then to return to the longer bit time at the CRC delimiter, before the receivers transmit their acknowledge bits. See also Figure 20.

In addition, the effective data rate is increased by allowing longer data fields. CAN FD allows the transmission of up to 64 data bytes compared to the 8 data bytes from the standard CAN.

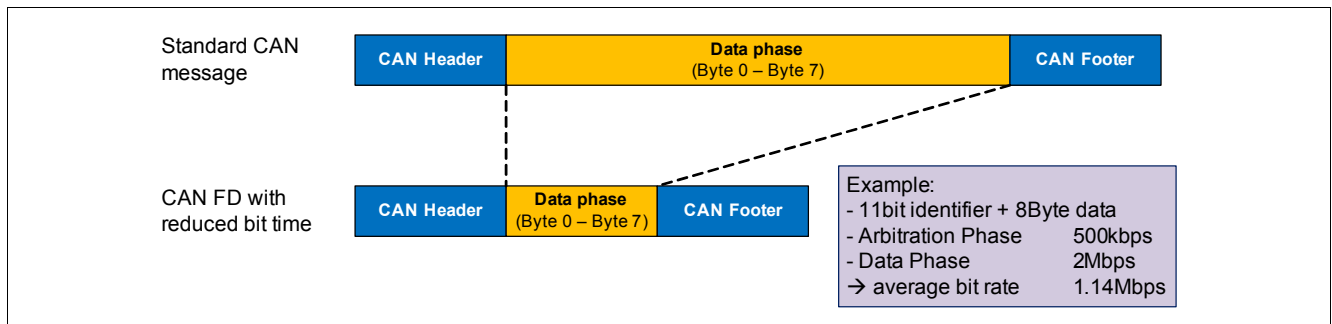

Figure 20 Bite Rate Increase with CAN FD vs. Standard CAN

Not only the physical layer must support CAN FD but also the CAN controller. In case the CAN controller is not able to support CAN FD then the respective CAN node must at least tolerate CAN FD communication. This CAN FD tolerant mode is realized in the physical layer in combination with CAN Partial Networking. The TLE926x-3QX variants of this family also support the CAN FD tolerant mode.

9.2.1 CAN OFF Mode

The CAN OFF Mode is the default mode after power-up of the SBC. It is available in all SBC Modes and is intended to completely stop CAN activities or when CAN communication is not needed. The CANH/L bus interface acts as a high impedance input with a very small leakage current. In CAN OFF Mode, a wake-up event on the bus will be ignored.

9.2.2 CAN Normal Mode

The CAN Transceiver is enabled via SPI in SBC Normal Mode. CAN Normal Mode is designed for normal data transmission/reception within the HS-CAN network. The Mode is available in SBC Normal Mode and in SBC Stop Mode. The bus biasing is set to $V_{CAN}/2$.

Transmission

The signal from the microcontroller is applied to the TXDCAN input of the SBC. The bus driver switches the CANH/L output stages to transfer this input signal to the CAN bus lines.

Enabling sequence

The CAN transceiver requires an enabling time $t_{CAN,EN}$ before a message can be sent on the bus. This means that the TXDCAN signal can only be pulled LOW after the enabling time. If this is not ensured, then the TXDCAN needs to be set back to HIGH (=recessive) until the enabling time is completed.

Only the next dominant bit will be transmitted on the bus.

Figure 21 shows different scenarios and explanations for CAN enabling.

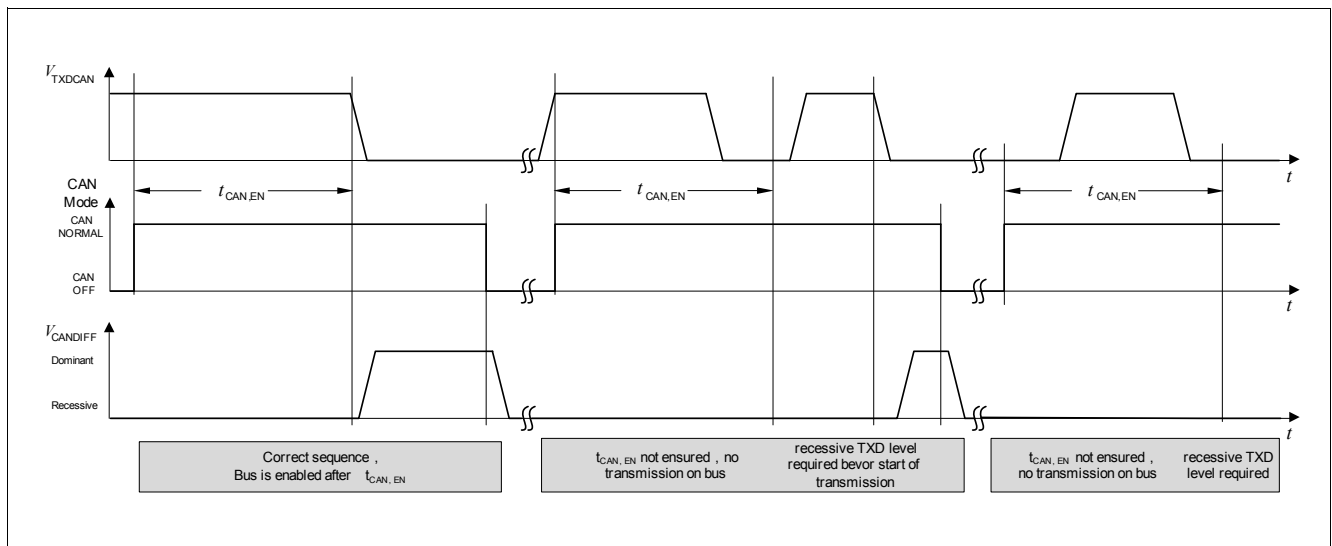

Figure 21 CAN Transceiver Enabling Sequence

Reduced Electromagnetic Emission

To reduce electromagnetic emissions (EME), the bus driver controls CANH/L slopes symmetrically.

Reception

Analog CAN bus signals are converted into digital signals at RXD via the differential input receiver.

9.2.3 CAN Receive Only Mode

In CAN Receive Only Mode (RXD only), the driver stage is de-activated but reception is still operational. This mode is accessible by an SPI command in Normal Mode and in Stop Mode. The bus biasing is set to VCAN/2.

9.2.4 CAN Wake Capable Mode

This mode can be used in SBC Stop, Sleep, Restart and Normal Mode and it is used to monitor bus activities. It is automatically accessed in SBC Fail-Safe Mode. Both bus pins CANH/L are connected to GND via the input resistors.

A wake-up signal on the bus results in a change of behavior of the SBC, as described in Table 12. The pins CANH/L are terminated to typ. 2.5V through the input resistors. As a wake-up signalization to the microcontroller, the RXD_CAN pin is set LOW and will stay LOW until the CAN transceiver is changed to any other mode. After a wake-up event, the transceiver can be switched to CAN Normal Mode for communication via SPI.

As shown in Figure 22, a wake-up pattern is signaled on the bus by two consecutive dominant bus levels for at least t_{Wake1} (filter time $t > t_{Wake1}$), each separated by a recessive bus level of less than t_{Wake2} .

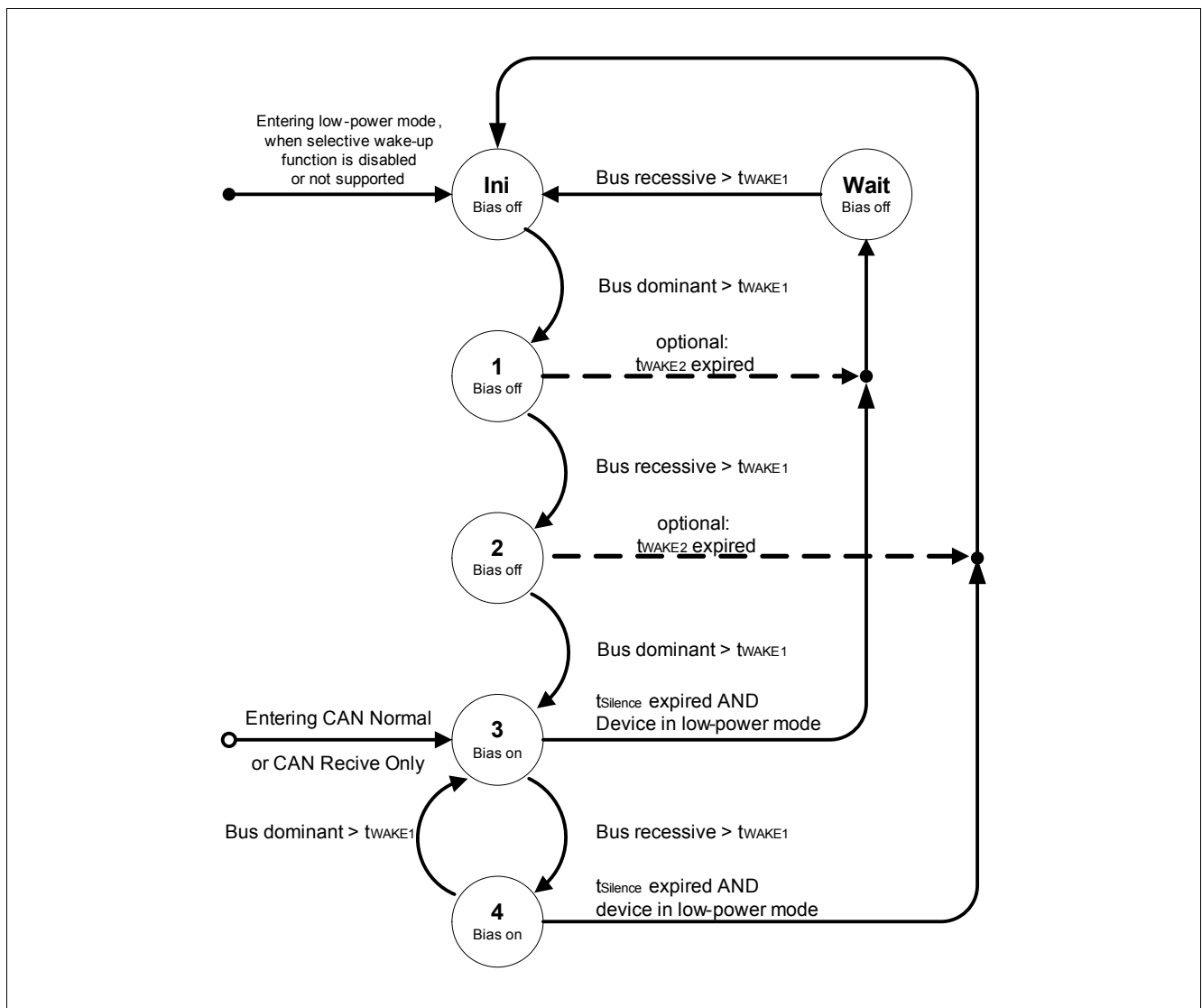

Figure 22 WUP detection following the definition in ISO 11898-5

Rearming the Transceiver for Wake Capability

After a BUS wake-up event, the transceiver is woken. However, the CAN transceiver mode bits will still show wake capable (=‘01’) so that the RXD signal will be pulled low. There are two possibilities how the CAN transceiver’s wake capable mode is enabled again after a wake event:

- The CAN transceiver mode must be toggled, i.e. switched from Wake Capable Mode to CAN Normal Mode, CAN Receive Only Mode or CAN Off, before switching to CAN Wake Capable Mode again.
- Rearming is done automatically when the SBC is changed to SBC Stop, SBC Sleep, or SBC Fail-Safe Mode to ensure wake-up capability.

Note: It is not necessary to clear the CAN wake-up bit CAN_WU to become wake capable again. It is sufficient to toggle the CAN mode.

Note: The CAN module is supplied by an internal voltage when in CAN Wake Capable Mode, i.e. the module must not be supplied through the VCAN pin during this time. Before changing the CAN Mode to Normal Mode, the supply of VCAN has to be activated first.

Wake-Up in SBC Stop and Normal Mode

In SBC Stop Mode, if a wake-up is detected, it is always signaled by the INT output and in the WK_STAT_1 SPI register. It is also signaled by RXDCAN pulled to low. The same applies for the SBC Normal Mode. The microcontroller should set the device from SBC Stop Mode to SBC Normal Mode, there is no automatic transition to Normal Mode.

For functional safety reasons, the watchdog will be automatically enabled in SBC Stop Mode after a Bus wake event in case it was disabled before (if bit WD_EN_WK_BUS was configured to HIGH before).

Wake-Up in SBC Sleep Mode

Wake-up is possible via a CAN message (filter time $t > t_{Wake1}$). The wake-up automatically transfers the SBC into the SBC Restart Mode and from there to Normal Mode the corresponding RXD pin is set to LOW. The microcontroller is able to detect the low signal on RXD and to read the wake source out of the WK_STAT_1 register via SPI. No interrupt is generated when coming out of Sleep Mode. The microcontroller can now for example switch the CAN transceiver into CAN Normal Mode via SPI to start communication.

Table 12 Action due to CAN Bus Wake-Up

| SBC Mode | SBC Mode after Wake | VCC1 | INT | RXD |
|----------------|---------------------|------------|------|-----|
| Normal Mode | Normal Mode | ON | LOW | LOW |
| Stop Mode | Stop Mode | ON | LOW | LOW |
| Sleep Mode | Restart Mode | Ramping Up | HIGH | LOW |
| Restart Mode | Restart Mode | ON | HIGH | LOW |
| Fail-Safe Mode | Restart Mode | Ramping up | HIGH | LOW |

9.2.5 TXD Time-out Feature

If the TXD signal is dominant for a time $t > t_{\text{TXD_CAN_TO}}$, in CAN Normal Mode, the TXD time-out function deactivates the transmission of the signal at the bus. This is implemented to prevent the bus from being blocked permanently due to an error. The transmitter is disabled and the transceiver is switched to Receive Only Mode. The failure is stored in the SPI flag **CAN_FAIL**. The CAN transmitter stage is activated again after the dominant time-out condition is removed and the transceiver is automatically switched back to CAN Normal Mode. The transceiver configuration stays unchanged.

9.2.6 Bus Dominant Clamping

If the HS CAN bus signal is dominant for a time $t > t_{\text{BUS_CAN_TO}}$, regardless of the CAN transceiver mode a bus dominant clamping is detected and the SPI bit **CAN_FAIL** is set. The transceiver configuration stays unchanged.

9.2.7 Under Voltage Detection

The voltage at the CAN supply pin is monitored in CAN Normal Mode only. In case of VCAN under voltage a signalization via SPI bit **VCAN_UV** is triggered and the SBC disables the transmitter stage. If the CAN supply reaches a higher level than the under voltage detection threshold ($\text{VCAN} > \text{VCAN_UV}$), the transceiver is automatically switched back to CAN Normal Mode. The transceiver configuration stays unchanged.

9.3 Electrical Characteristics

Table 13 Electrical Characteristics

$V_S = 5.5\text{ V to }28\text{ V}$; $T_j = -40\text{ °C to }+150\text{ °C}$; $4.75\text{ V} < V_{CAN} < 5.25\text{ V}$; $R_L = 60\Omega$; CAN Normal Mode; all voltages with respect to ground, positive current flowing into pin (unless otherwise specified)

| Parameter | Symbol | Values | | | Unit | Note / Test Condition | Number |
|---|------------------|--------|------|------|------|--|-----------|
| | | Min. | Typ. | Max. | | | |
| CAN Bus Receiver | | | | | | | |
| Differential Receiver Threshold Voltage, recessive to dominant edge | V_{diff,rd_N} | – | 0.80 | 0.90 | V | $V_{diff} = V_{CANH} - V_{CANL}$; $-12\text{V} \leq V_{CM}(\text{CAN}) \leq +12\text{ V}$; CAN Normal Mode | P_10.3.2 |
| Differential Receiver Threshold Voltage, dominant to recessive edge | V_{diff,dr_N} | 0.50 | 0.60 | – | V | $V_{diff} = V_{CANH} - V_{CANL}$; $-12\text{V} \leq V_{CM}(\text{CAN}) \leq +12\text{ V}$; CAN Normal Mode | P_10.3.3 |
| Common Mode Range | CMR | -12 | – | 12 | V | ¹⁾ | P_10.3.4 |
| CANH, CANL Input Resistance | R_{in} | 20 | 40 | 50 | kΩ | CAN Normal / Wake capable Mode; Recessive state | P_10.3.6 |
| Differential Input Resistance | R_{diff} | 40 | 80 | 100 | kΩ | CAN Normal / Wake capable Mode; Recessive state | P_10.3.7 |
| Input Resistance Deviation between CANH and CANL | ΔR_i | -3 | – | 3 | % | ¹⁾ Recessive state | P_10.3.38 |
| Input Capacitance CANH, CANL versus GND | C_{in} | – | 20 | 40 | pF | ¹⁾ VTXD = 5V | P_10.3.39 |
| Differential Input Capacitance | C_{diff} | – | 10 | 20 | pF | ¹⁾ VTXD = 5V | P_10.3.40 |
| Wake-up Receiver Threshold Voltage, recessive to dominant edge | V_{diff,rd_W} | – | 0.8 | 1.15 | V | $-12\text{V} \leq V_{CM}(\text{CAN}) \leq +12\text{ V}$; CAN Wake Capable Mode | P_10.3.8 |
| Wake-up Receiver Threshold Voltage, dominant to recessive edge | V_{diff,dr_W} | 0.4 | 0.7 | – | V | $-12\text{V} \leq V_{CM}(\text{CAN}) \leq +12\text{ V}$; CAN Wake Capable Mode | P_10.3.9 |

Table 13 Electrical Characteristics (cont'd)

$V_S = 5.5 \text{ V to } 28 \text{ V}$; $T_j = -40 \text{ }^\circ\text{C to } +150 \text{ }^\circ\text{C}$; $4.75 \text{ V} < V_{\text{CAN}} < 5.25 \text{ V}$; $R_L = 60\Omega$; CAN Normal Mode; all voltages with respect to ground, positive current flowing into pin (unless otherwise specified)

| Parameter | Symbol | Values | | | Unit | Note / Test Condition | Number |
|--|-------------------------|--------|------|------|------|--|-----------|
| | | Min. | Typ. | Max. | | | |
| CAN Bus Transmitter | | | | | | | |
| CANH/CANL Recessive Output Voltage (CAN Normal Mode) | $V_{\text{CANL/H_NM}}$ | 2.0 | – | 3.0 | V | CAN Normal Mode; $V_{\text{TXD}} = V_{\text{CC1}}$; no load | P_10.3.11 |
| CANH/CANL Recessive Output Voltage (CAN Wake Capable Mode) | $V_{\text{CANL/H_LP}}$ | -0.1 | – | 0.1 | V | CAN Wake Capable Mode; $V_{\text{TXD}} = V_{\text{CC1}}$; no load | P_10.3.43 |
| CANH, CANL Recessive Output Voltage Difference $V_{\text{diff}} = V_{\text{CANH}} - V_{\text{CANL}}$ (CAN Normal Mode) | $V_{\text{diff_r_N}}$ | -500 | – | 50 | mV | CAN Normal Mode $V_{\text{TXD}} = V_{\text{CC1}}$; no load | P_10.3.12 |
| CANH, CANL Recessive Output Voltage Difference $V_{\text{diff}} = V_{\text{CANH}} - V_{\text{CANL}}$ (CAN Wake Capable Mode) | $V_{\text{diff_r_W}}$ | -500 | – | 50 | mV | CAN Wake Capable Mode; $V_{\text{TXD}} = V_{\text{CC1}}$; no load | P_10.3.41 |
| CANL Dominant Output Voltage | V_{CANL} | 0.5 | – | 2.25 | V | CAN Normal Mode; $V_{\text{TXD}} = 0 \text{ V}$; $V_{\text{CAN}} = 5 \text{ V}$; $50\Omega \leq R_L \leq 65\Omega$ | P_10.3.13 |
| CANH Dominant Output Voltage | V_{CANH} | 2.75 | – | 4.5 | V | CAN Normal Mode; $V_{\text{TXD}} = 0 \text{ V}$; $V_{\text{CAN}} = 5 \text{ V}$; $50\Omega \leq R_L \leq 65\Omega$ | P_10.3.14 |
| CANH, CANL Dominant Output Voltage Difference $V_{\text{diff}} = V_{\text{CANH}} - V_{\text{CANL}}$ | $V_{\text{diff_d_N}}$ | 1.5 | – | 3.0 | V | CAN Normal Mode; $V_{\text{TXD}} = 0 \text{ V}$; $V_{\text{CAN}} = 5 \text{ V}$; $50\Omega \leq R_L \leq 65\Omega$ | P_10.3.16 |
| Driver Symmetry $V_{\text{SYM}} = V_{\text{CANH}} + V_{\text{CANL}}$ | V_{SYM} | 4.5 | – | 5.5 | V | ²⁾ CAN Normal Mode; $V_{\text{TXD}} = 0 \text{ V} / 5 \text{ V}$; $V_{\text{CAN}} = 5 \text{ V}$; $C_{\text{SPLIT}} = 4.7\text{nF}$; $50\Omega \leq R_L \leq 60\Omega$ | P_10.3.42 |
| CANH Short Circuit Current | I_{CANHsc} | -100 | -80 | -50 | mA | CAN Normal Mode; $V_{\text{CANHshort}} = 0 \text{ V}$ | P_10.3.17 |

Table 13 Electrical Characteristics (cont'd)

$V_S = 5.5 \text{ V to } 28 \text{ V}$; $T_j = -40 \text{ }^\circ\text{C to } +150 \text{ }^\circ\text{C}$; $4.75 \text{ V} < V_{\text{CAN}} < 5.25 \text{ V}$; $R_L = 60\Omega$; CAN Normal Mode; all voltages with respect to ground, positive current flowing into pin (unless otherwise specified)

| Parameter | Symbol | Values | | | Unit | Note / Test Condition | Number |
|--|--|-----------------------------|------------------------------|-----------------------------|---------------|--|-----------|
| | | Min. | Typ. | Max. | | | |
| CANL Short Circuit Current | I_{CANLsc} | 50 | 80 | 100 | mA | CAN Normal Mode $V_{\text{CANLshort}} = 18 \text{ V}$ | P_10.3.18 |
| Leakage Current (unpowered device) | $I_{\text{CANH,ik}}$ $I_{\text{CANL,ik}}$ | – | 5 | 7.5 | μA | $V_S = V_{\text{CAN}} = 0\text{V}$; $0\text{V} < V_{\text{CANH,L}} \leq 5\text{V}$; ³⁾ $R_{\text{test}} = 0 / 47 \text{ k}\Omega$ | P_10.3.19 |
| Receiver Output RXD | | | | | | | |
| HIGH level Output Voltage | $V_{\text{RXD,H}}$ | $0.8 \times V_{\text{CC1}}$ | – | – | V | CAN Normal Mode $I_{\text{RXD(CAN)}} = -2 \text{ mA}$; | P_10.3.21 |
| LOW Level Output Voltage | $V_{\text{RXD,L}}$ | – | – | $0.2 \times V_{\text{CC1}}$ | V | CAN Normal Mode $I_{\text{RXD(CAN)}} = 2 \text{ mA}$; | P_10.3.22 |
| Transmission Input TXD | | | | | | | |
| HIGH Level Input Voltage Threshold | $V_{\text{TXD,H}}$ | – | – | $0.7 \times V_{\text{CC1}}$ | V | CAN Normal Mode recessive state | P_10.3.23 |
| LOW Level Input Voltage Threshold | $V_{\text{TXD,L}}$ | $0.3 \times V_{\text{CC1}}$ | – | – | V | CAN Normal Mode dominant state | P_10.3.24 |
| TXD Input Hysteresis | $V_{\text{TXD,hys}}$ | – | $0.12 \times V_{\text{CC1}}$ | – | mV | ¹⁾ | P_10.3.25 |
| TXD Pull-up Resistance | R_{TXD} | 20 | 40 | 80 | k Ω | – | P_10.3.26 |
| CAN Transceiver Enabling Time | $t_{\text{CAN,EN}}$ | – | 10 | – | μs | ⁴⁾ CSN = HIGH to first valid transmitted TXD dominant | P_10.3.27 |
| Dynamic CAN-Transceiver Characteristics | | | | | | | |
| Min. Dominant Time for Bus Wake-up | t_{Wake1} | 0.50 | – | 3 | μs | $-12\text{V} \leq V_{\text{CM(CAN)}} \leq +12 \text{ V}$; CAN Wake capable Mode | P_10.3.28 |
| Wake-up Time-out, Recessive Bus | t_{Wake2} | 0.5 | – | 10 | ms | ⁴⁾ CAN Wake capable Mode | P_10.3.29 |
| WUP Wake-up Reaction Time | $t_{\text{WU_WUP}}$ | – | – | 100 | μs | ⁴⁾⁵⁾⁶⁾ Wake-up reaction time after a valid WUP on CAN bus; | P_10.3.44 |

Table 13 Electrical Characteristics (cont'd)

$V_S = 5.5\text{ V to }28\text{ V}$; $T_j = -40\text{ °C to }+150\text{ °C}$; $4.75\text{ V} < V_{CAN} < 5.25\text{ V}$; $R_L = 60\Omega$; CAN Normal Mode; all voltages with respect to ground, positive current flowing into pin (unless otherwise specified)

| Parameter | Symbol | Values | | | Unit | Note / Test Condition | Number |
|---|----------------|--------|------|------|------|--|-----------|
| | | Min. | Typ. | Max. | | | |
| Propagation Delay TXD-to-RXD LOW (recessive to dominant) | $t_{d(L),TR}$ | – | 150 | 255 | ns | ²⁾ CAN Normal Mode $C_L = 100\text{ pF}$; $R_L = 60\ \Omega$; $V_{CAN} = 5\text{ V}$; $C_{RXD} = 15\text{ pF}$ | P_10.3.30 |
| Propagation Delay TXD-to-RXD HIGH (dominant to recessive) | $t_{d(H),TR}$ | – | 150 | 255 | ns | ²⁾ CAN Normal Mode $C_L = 100\text{ pF}$; $R_L = 60\ \Omega$; $V_{CAN} = 5\text{ V}$; $C_{RXD} = 15\text{ pF}$ | P_10.3.31 |
| Propagation Delay TXD LOW to bus dominant | $t_{d(L),T}$ | – | 50 | – | ns | CAN Normal Mode $C_L = 100\text{ pF}$; $R_L = 60\ \Omega$; $V_{CAN} = 5\text{ V}$; | P_10.3.32 |
| Propagation Delay TXD HIGH to bus recessive | $t_{d(H),T}$ | – | 50 | – | ns | CAN Normal Mode $C_L = 100\text{ pF}$; $R_L = 60\ \Omega$; $V_{CAN} = 5\text{ V}$; | P_10.3.33 |
| Propagation Delay bus dominant to RXD LOW | $t_{d(L),R}$ | – | 100 | – | ns | CAN Normal Mode $C_L = 100\text{ pF}$; $R_L = 60\ \Omega$; $V_{CAN} = 5\text{ V}$; $C_{RXD} = 15\text{ pF}$ | P_10.3.34 |
| Propagation Delay bus recessive to RXD HIGH | $t_{d(H),R}$ | – | 100 | – | ns | CAN Normal Mode $C_L = 100\text{ pF}$; $R_L = 60\ \Omega$; $V_{CAN} = 5\text{ V}$; $C_{RXD} = 15\text{ pF}$ | P_10.3.35 |
| Recessive Bit Width on RXD (CAN FD up to 2Mbps) | $t_{bit(RXD)}$ | 400 | – | 550 | ns | CAN Normal Mode $C_L = 100\text{ pF}$; $R_L = 60\ \Omega$; $V_{CAN} = 5\text{ V}$; $C_{RXD} = 15\text{ pF}$; $t_{bit(TXD)} = 500\text{ ns}$; Refer to Figure 24 | P_10.3.46 |

Table 13 Electrical Characteristics (cont'd)

$V_S = 5.5\text{ V to }28\text{ V}$; $T_j = -40\text{ }^\circ\text{C to }+150\text{ }^\circ\text{C}$; $4.75\text{ V} < V_{CAN} < 5.25\text{ V}$; $R_L = 60\Omega$; CAN Normal Mode; all voltages with respect to ground, positive current flowing into pin (unless otherwise specified)

| Parameter | Symbol | Values | | | Unit | Note / Test Condition | Number |
|---------------------------------|--------------------|--------|------|------|------|-------------------------------|-----------|
| | | Min. | Typ. | Max. | | | |
| TXD Permanent Dominant Time-out | $t_{TXD_CAN_TO}$ | – | 2 | – | ms | ⁴⁾ CAN Normal Mode | P_10.3.36 |
| BUS Permanent Dominant Time-out | $t_{BUS_CAN_TO}$ | – | 2 | – | ms | ⁴⁾ CAN Normal Mode | P_10.3.37 |

- 1) Not subject to production test, specified by design.
- 2) $f_{TXD} = 250\text{ kHz}$ rectangular signal, duty cycle = 50%;
- 3) Rtest between supply (V_S / V_{CAN}) and 0V (GND);
- 4) Not subject to production test, tolerance defined by internal oscillator tolerance;
- 5) Wake-up is signaled via INT pin activation in SBC Stop Mode and via VCC1 ramping up with wake from SBC Sleep Mode;
- 6) Time starts with end of last dominant phase of WUP;

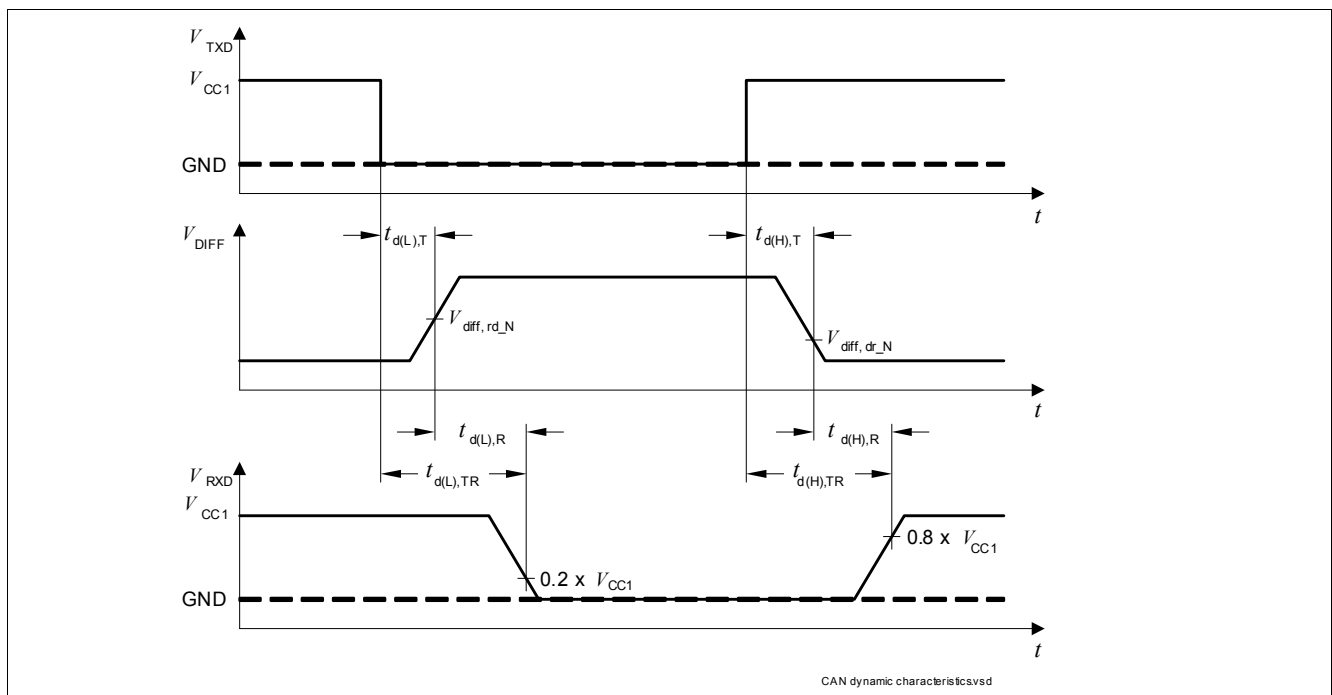

Figure 23 Timing Diagrams for Dynamic Characteristics

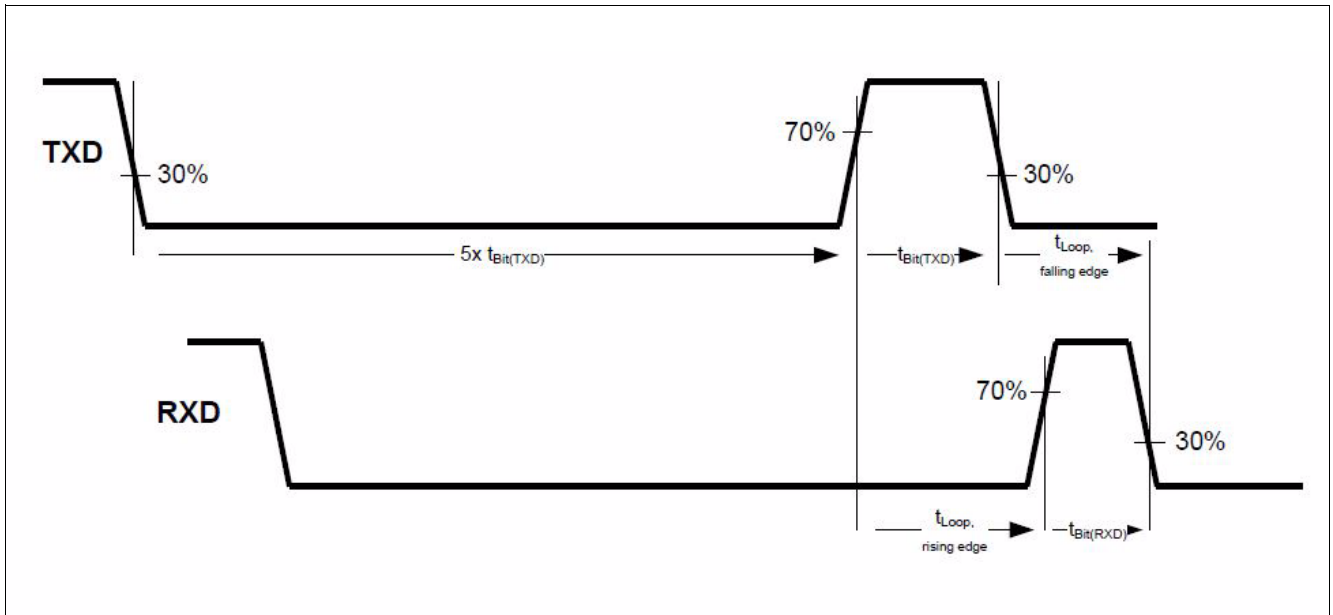

Figure 24 Timing Diagrams for RXD recessive bit width definition $t_{bit(RXD)}$

10 Wake and Voltage Monitoring Inputs

10.1 Block Description

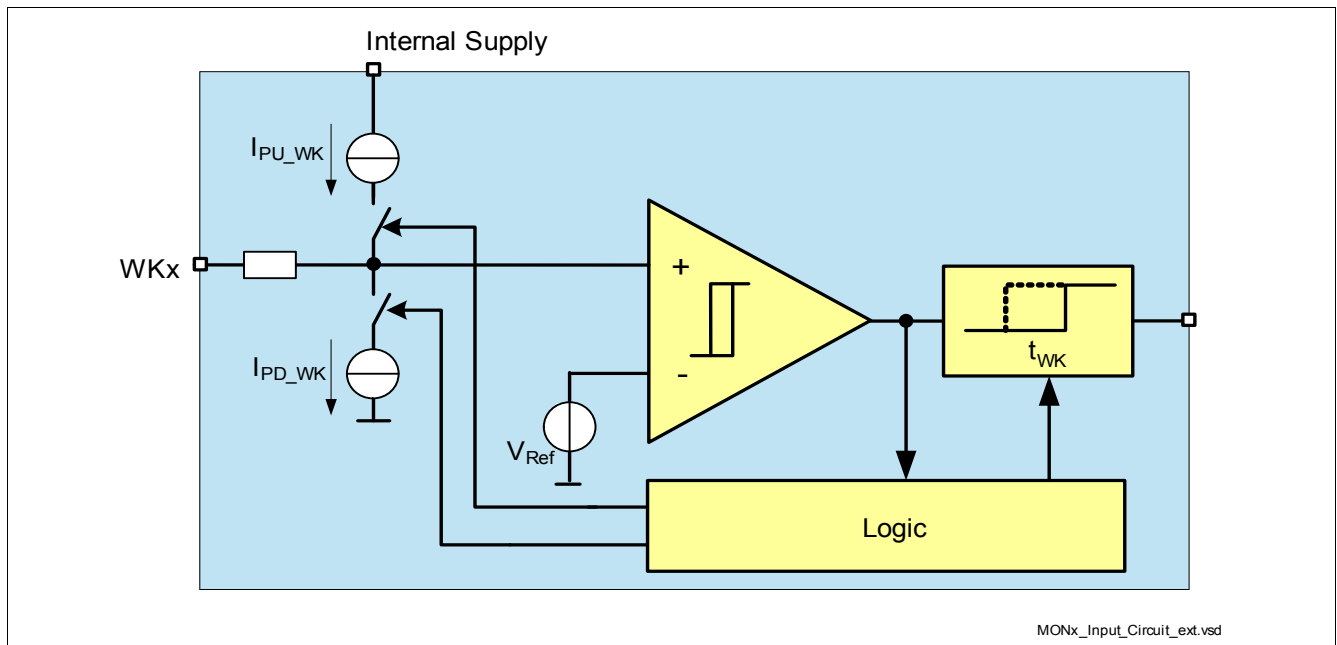

Figure 25 Wake Input Block Diagram

Features

- Three High-Voltage inputs with a 3V (typ.) threshold voltage
- Alternate Measurement function for high-voltage sensing via WK1 and WK2
- Wake-up capability for power saving modes
- Edge sensitive wake feature LOW to HIGH and HIGH to LOW
- Pull-up and Pull-down current sources, configurable via SPI
- Selectable configuration for static sense or cyclic sense working with TIMER1, TIMER2
- In SBC Normal and SBC Stop Mode the level of the WK pin can be read via SPI even if the respective WK is not enabled as a wake source.

10.2 Functional Description

The wake input pins are edge-sensitive inputs with a switching threshold of typically 3V. This means that both transitions, HIGH to LOW and LOW to HIGH, result in a signalization by the SBC. The signalization occurs either in triggering the interrupt in SBC Normal Mode and SBC Stop Mode or by a wake up of the device in SBC Sleep and SBC Fail-Safe Mode.

Two different wake detection modes can be selected via SPI:

- Static sense: WK inputs are always active
- Cyclic sense: WK inputs are only active for a certain time period (see [Chapter 5.2.1](#))

Two different filter times of 16µs or 64µs can be selected to avoid a parasitic wake-up due to transients or EMC disturbances in static sense configuration.

The filter time (t_{FWK1} , t_{FWK2}) is triggered by a level change crossing the switching threshold and a wake signal is recognized if the input level will not cross again the threshold during the selected filter time.

[Figure 26](#) shows a typical wake-up timing and parasitic filter.

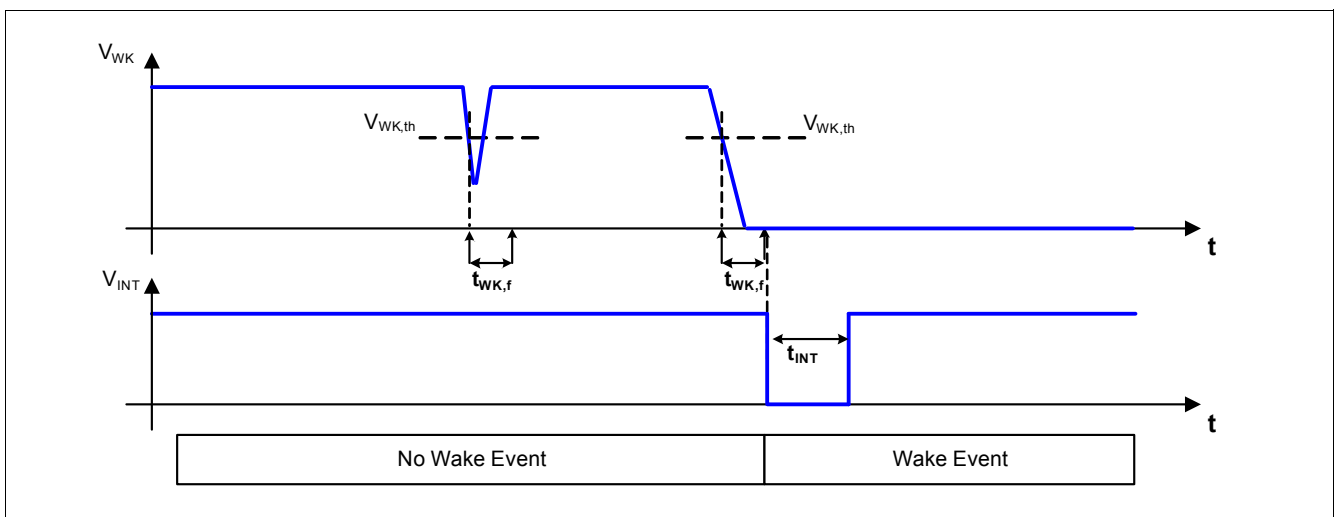

Figure 26 Wake-up Filter Timing for Static Sense

The wake-up capability for each WK pin can be enabled or disabled via SPI command in the [WK_CTRL_2](#) register.

The wake source for a wake via a WKx pin can always be read in the register [WK_STAT_1](#) at the bits WK1_WU, WK2_WU, and WK3_WU.

The actual voltage level of the WK pin (LOW or HIGH) can always be read in SBC Normal and SBC Stop Mode in the register [WK_LVL_STAT](#). During Cyclic Sense, the register show the sampled levels of the respective WK pin.

If FO2...3 are configured as WK inputs in its alternative function (16µs static filter time), then the wake events will be signalled in the register [WK_STAT_2](#).

10.2.1 Wake Input Configuration

To ensure a defined and stable voltage levels at the internal comparator input it is possible to configure integrated current sources via the SPI register **WK_PUPD_CTRL**. In addition, the wake detection modes (including the filter time) can be configured via the SPI register **WK_FLT_CTRL**. An example illustration for the automatic switching configuration is shown in **Figure 27**.

Table 14 Pull-Up / Pull-Down Resistor

| WKx_PUPD_1 | WKx_PUPD_0 | Current Sources | Note |
|------------|------------|---------------------|--|
| 0 | 0 | no current source | WKx input is floating if left open (default setting) |
| 0 | 1 | pull-down | WKx input internally pulled to GND |
| 1 | 0 | pull-up | WKx input internally pulled to internal 5V supply |
| 1 | 1 | Automatic switching | If a high level is detected at the WKx input the pull-up source is activated, if low level is detected the pull down is activated. |

Note: If there is no pull-up or pull-down configured on the WK input, then the respective input should be tied to GND or VS on board to avoid unintended floating of the pin and subsequent wake events.

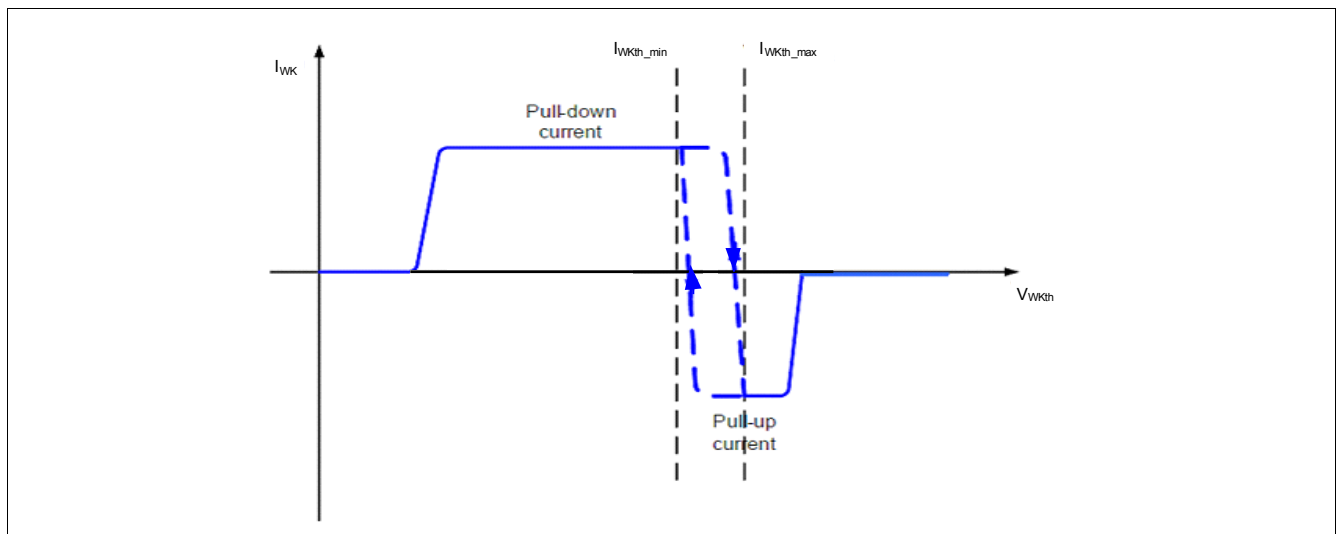

Figure 27 Illustration for Pull-Up / Down Current Sources with Automatic Switching Configuration

Table 15 Wake Detection Configuration and Filter Time

| WKx_FLT_1 | WKx_FLT_0 | Filter Time | Description |
|-----------|-----------|-------------|--|
| 0 | 0 | Config A | static sense, 16µs filter time |
| 0 | 1 | Config B | static sense, 64µs filter time |
| 1 | 0 | Config C | Cyclic sense, Timer 1, 16µs filter time. Period, On-time configurable in register TIMER1_CTRL |
| 1 | 1 | Config D | Cyclic sense, Timer 2, 16µs filter time. Period, On-time configurable in register TIMER2_CTRL |

Config A and B are intended for static sense with two different filter times.

Config C or D are intended for cyclic sense configuration. With the filter settings, the respective timer needs to be assigned to one or more HS output, which supplies an external circuit connected to the WKx pin, e.g. HS1 controlled by Timer 2 (HS1 = 010) and connected to WK3 via an switch circuitry - see also **Chapter 5.2**.

10.2.2 Alternate Measurement Function with WK1 and WK2

10.2.2.1 Block Description

This function provides the possibility to measure a voltage, e.g. the unbuffered battery voltage, with the protected WK1 HV-input. The measured voltage is routed out at WK2. It allows for example a voltage compensation for LED lighting by changing the duty cycle of the High-Side outputs. A simple voltage divider needs to be placed externally to provide the correct voltage level to the microcontroller A/D converter input.

The function is available in SBC Normal Mode and it is disabled in all other modes to allow a low-quiescent current operation. The measurement function can be used instead of the WK1 and WK2 wake and level signalling capability.

The benefits of the function is that the signal is measured by a HV-input pin and that there is no current flowing through the resistor divider during low-power modes.

The functionality is shown in a simplified application diagram in [Figure 48](#).

10.2.2.2 Functional Description

This measurement function is by default disabled. In this case, WK1 and WK2 have the regular wake and voltage level signalization functionality. The switch S1 is open for this configuration (see [Figure 48](#)).

The measurement function can be enabled via the SPI bit [WK_MEAS](#).

If [WK_MEAS](#) is set to '1', then the measurement function is enabled and switch S1 is closed in SBC Normal Mode. S1 is open in all other SBC modes. If this function the pull-up and down currents of WK1 and WK2 are disabled, and the internal WK1 and WK2 signals are gated. In addition, the settings for WK1 and WK2 in the registers [WK_PUPD_CTRL](#), [WK_FLT_CTRL](#) and [WK_CTRL_2](#) are ignored but changing these setting is not prevented. The registers [WK_STAT_1](#) and [WK_LVL_STAT](#) are not updated with respect to the inputs WK1 and WK2.

However, if only WK1 or WK2 are set as wake sources and a SBC Sleep Mode command is set, then the [SPI_FAIL](#) flag will be set and the SBC will be changed into SBC Restart Mode (see [Chapter 5.1](#) also for wake capability of WK1 and WK2).

Table 16 Differences between Normal WK Function and Measurement Function

| Affected Settings/Modules for WK1 and WK2 Inputs | WK_MEAS = 0 | WK_MEAS = 1 |
|--|--|--|
| S1 configuration | 'open' | 'closed' in SBC Normal Mode, 'open' in all other SBC Modes |
| Internal WK1 & WK2 signal processing | Default wake and level signaling function, WK_STAT_1 , WK_STAT_2 are updated accordingly | 'WK1...2 inputs are gated internally, WK_STAT_1 , WK_STAT_2 are not updated |
| WK1_EN , WK2_EN | Wake-up via WK1 and WK2 possible if bits are set | setting the bits is ignored and not prevented. If only WK1_EN , WK2_EN are set while trying to go to SBC Sleep Mode, then the SPI_FAIL flag will be set and the SBC will be changed into SBC Restart Mode. |
| WK_PUPD_CTRL | normal configuration is possible | no pull-up or pull-down enabled |
| WK_FLT_CTRL | normal configuration is possible | setting the bits is ignored and not prevented |

Note: There is a diode in series to the switch S1 (not shown in the [Figure 48](#)), which will influence the temperature behavior of the switch.

10.3 Electrical Characteristics

Table 17 Electrical Characteristics

$V_S = 5.5\text{ V to }28\text{ V}$; $T_j = -40\text{ °C to }+150\text{ °C}$; all voltages with respect to ground, positive current flowing into pin (unless otherwise specified)

| Parameter | Symbol | Values | | | Unit | Note / Test Condition | Number |
|--|-----------------|--------|------|------|---------------|--|-----------|
| | | Min. | Typ. | Max. | | | |
| WK1...WK3 Input Pin Characteristics | | | | | | | |
| Wake-up/monitoring threshold voltage | V_{WKth} | 2 | 3 | 4 | V | without external serial resistor R_S (with R_S : $\Delta V = I_{PD/PU} * R_S$); hysteresis included | P_12.3.1 |
| Threshold hysteresis | $V_{WKNth,hys}$ | 0.1 | - | 0.7 | V | without external serial resistor R_S (with R_S : $\Delta V = I_{PD/PU} * R_S$); | P_12.3.2 |
| WK pin Pull-up Current | I_{PU_WK} | -20 | -10 | -3 | μA | $V_{WK_IN} = 4\text{V}$ | P_12.3.3 |
| WK pin Pull-down Current | I_{PD_WK} | 3 | 10 | 20 | μA | $V_{WK_IN} = 2\text{V}$ | P_12.3.4 |
| Input leakage current | $I_{LK,I}$ | -2 | | 2 | μA | $0\text{ V} < V_{WK_IN} < 40\text{V}$ | P_12.3.5 |
| Drop Voltage across S1 switch | $V_{Drop,S1}$ | - | 1000 | - | mV | ¹⁾ Drop Voltage between WK1 and WK2 when enabled for voltage measurement; $I_{WK1} = 500\mu\text{A}$; $T_j = 25\text{°C}$ Refer to Figure 28 | P_12.3.13 |

Timing

| | | | | | | | |
|-----------------------|------------|---|----|---|---------------|---------------------------|----------|
| Wake-up filter time 1 | t_{FWK1} | - | 16 | - | μs | ²⁾ SPI Setting | P_12.3.6 |
| Wake-up filter time 2 | t_{FWK2} | - | 64 | - | μs | ²⁾ SPI Setting | P_12.3.7 |

1) Not subject to production test; specified by design

2) Not subject to production test, tolerance defined by internal oscillator tolerance

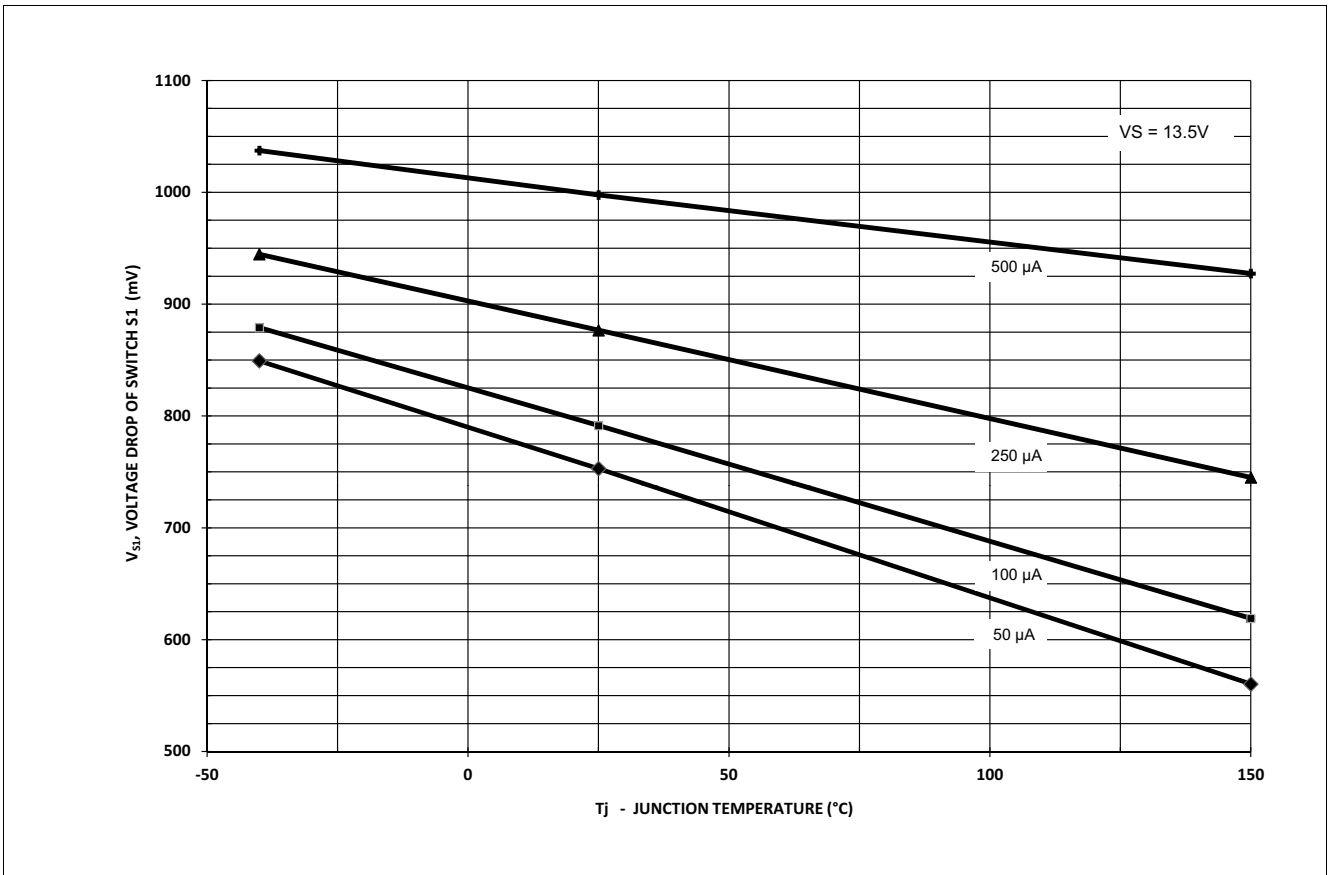

Figure 28 Typical Drop Voltage Characteristics of S1 (between WK1 & WK2)

11 Interrupt Function

11.1 Block and Functional Description

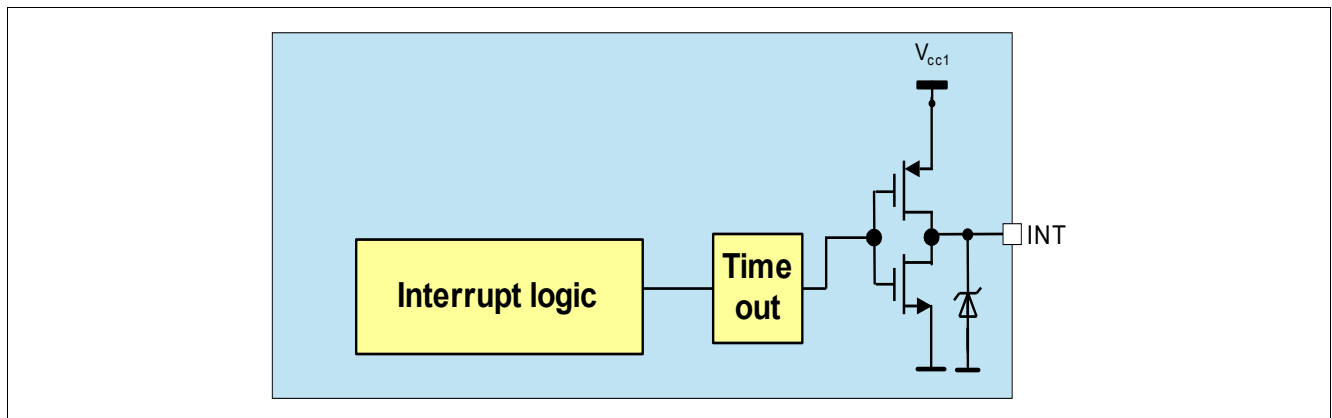

Figure 29 Interrupt Block Diagram

The interrupt is used to signalize special events in real time to the microcontroller. The interrupt block is designed as a push/pull output stage as shown in [Figure 29](#). An interrupt is triggered and the INT pin is pulled low (active low) for t_{INT} in SBC Normal and Stop Mode and it is released again once t_{INT} is expired. The minimum HIGH-time of INT between two consecutive interrupts is t_{INTD} . An interrupt does not cause a SBC mode change.

Two different interrupt classes could be selected via the SPI bit **INT_GLOBAL**:

- Class 1 (wake interrupt - **INT_GLOBAL**=0): all wake-up events stored in the wake status SPI register (**WK_STAT_1** and **WK_STAT_2**) cause an interrupt (default setting). An interrupt is only triggered if the respective function is also enabled as a wake source (including GPIOx if configured as a wake input).
- Class 2 (global interrupt - **INT_GLOBAL**=1): in addition to the wake-up events, all signalled failures stored in the other status registers cause an interrupt (the register **WK_LVL_STAT** is not generating interrupts)

Note: The errors which will cause SBC Restart or SBC Fail-Safe Mode (V_{cc1_UV} , WD_FAIL , $VCC1_SC$, $TSD2$, $FAILURE$) are the exceptions of an INT generation on status bits. Also POR and DEV_STAT_x and will not generate interrupts.

In addition to this behavior, an INT will be triggered when the SBC is sent to SBC Stop Mode and not all bits were cleared in the **WK_STAT_1** and **WK_STAT_2** register.

The SPI status registers are updated at every falling edge of the INT pulse. All interrupt events are stored in the respective register (except the register **WK_LVL_STAT**) until the register is read and cleared via SPI command. A second SPI read after reading out the respective status register is optional but recommended to verify that the interrupt event is not present anymore. The interrupt behavior is shown in [Figure 30](#) for class 1 interrupts. The behavior for class 2 is identical.

The INT pin is also used during SBC Init Mode to select the hardware configuration of the device. See [Chapter 5.1.1](#) for further information.

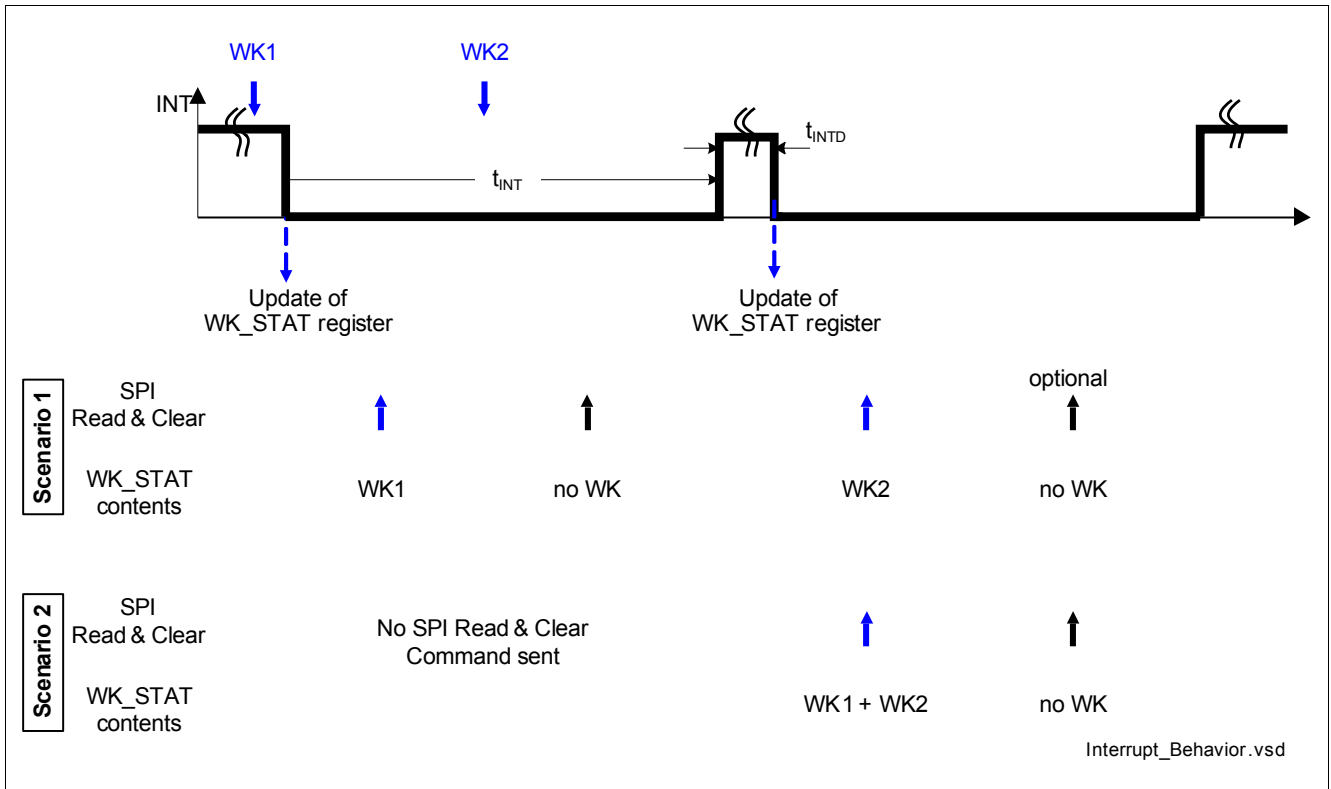

Figure 30 Interrupt Signalization Behavior

11.2 Electrical Characteristics

Table 18 Interrupt Output

$V_S = 5.5\text{ V to }28\text{ V}$; $T_j = -40\text{ °C to }+150\text{ °C}$; SBC Normal Mode; all voltages with respect to ground; positive current defined flowing into pin; unless otherwise specified.

| Parameter | Symbol | Values | | | Unit | Note / Test Condition | Number |
|--------------------------------------|-------------|----------------------|------|----------------------|---------------|---|----------|
| | | Min. | Typ. | Max. | | | |
| Interrupt Output; Pin INT | | | | | | | |
| INT High Output Voltage | $V_{INT,H}$ | $0.8 \times V_{CC1}$ | – | – | V | ¹⁾ $I_{INT} = -1\text{ mA}$; INT = OFF | P_13.2.1 |
| INT Low Output Voltage | $V_{INT,L}$ | – | – | $0.2 \times V_{CC1}$ | V | ¹⁾ $I_{INT} = 1\text{ mA}$; INT = ON | P_13.2.2 |
| INT Pulse Width | t_{INT} | – | 100 | – | μs | ²⁾ | P_13.2.3 |
| INT Pulse Minimum Delay Time | t_{INTD} | – | 100 | – | μs | ²⁾ between consecutive pulses | P_13.2.4 |
| Configuration Select; Pin INT | | | | | | | |
| Config Pull-down Resistance | R_{CFG} | – | 250 | – | k Ω | $V_{INT} = 5\text{ V}$ | P_13.2.5 |
| Config Select Filter Time | $t_{CFG,F}$ | – | 7 | – | μs | ²⁾ | P_13.2.6 |

1) Output Voltage Value also determines device configuration during SBC Init Mode

2) Not subject to production test, tolerance defined by internal oscillator tolerance.

12 Fail Outputs

12.1 Block and Functional Description

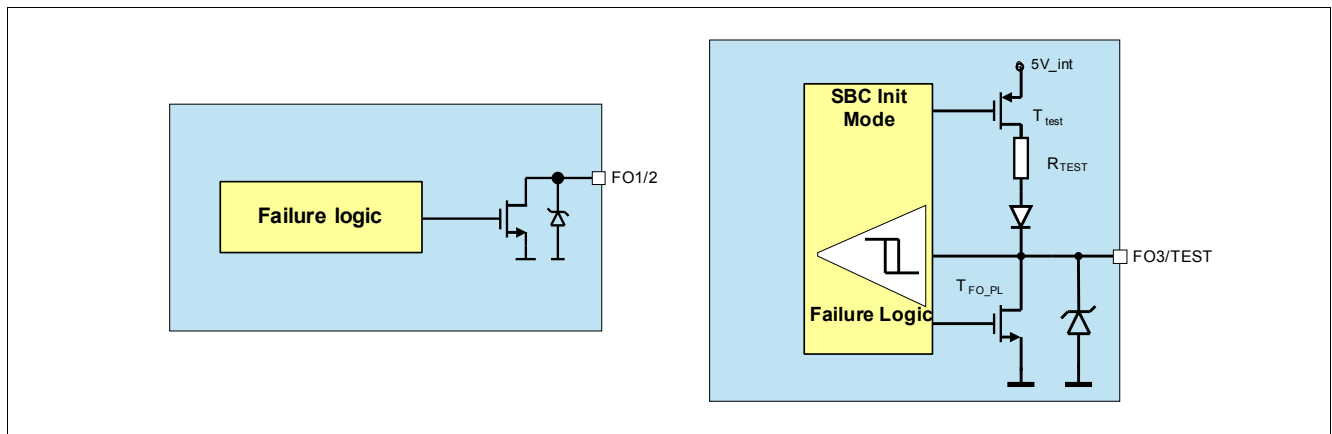

Figure 31 Simplified Fail Output Block Diagram for FO1/2 and for FO3/TEST

The fail outputs consist of a failure logic block and three open-drain outputs (FO1, FO2, FO3) with active-low signalization.

The fail outputs are activated due to following failure conditions:

- Watchdog trigger failure (For config 3&4 only after the 2nd watchdog trigger failure and for config 1&2 after 1st watchdog trigger failure)
- Thermal shutdown TSD2
- VCC1 short to GND
- VCC1 over voltage (only if the SPI bit **VCC1_OV_RST** is set)
- After 4 consecutive VCC1 under voltage event (see [Chapter 13.6](#) for details)

At the same time SBC Fail-Safe Mode is entered (exceptions are watchdog trigger failures depending on selected configurations - see [Chapter 5.1.1](#)).

The fail output activation is signalled in the SPI bit **FAILURE** of the register **DEV_STAT**.

For testing purposes only the Fail Outputs can also be activated via SPI by setting the bit **FO_ON**. This bit is independent of the FO failure bits. In case that there is no failure condition, the FO outputs can also be turned off again via SPI, i.e. no successful watchdog trigger is needed.

The entry of SBC Fail-Safe Mode due to a watchdog failure can be configured as described in [Chapter 5.1.1](#).

In order to deactivate the fail outputs in SBC Normal Mode the failure conditions must not be present anymore (e.g. TSD2, VCC1 short circuit, etc) and the bit **FAILURE** needs to be cleared via SPI command. In case of a **FAILURE** bit setting due to a watchdog fail, a successful WD trigger is needed in addition, i.e. **WD_FAIL** must be cleared. **WD_FAIL** will also be cleared when going to SBC Sleep or SBC Fail-Safe Mode due to another failure (not a WD failure) or if the watchdog is disabled in SBC Stop Mode.

Note: The Fail output pin is triggered for any of the above described failures. No FAILURE is caused for the 1st watchdog failure if selected for Config2.

The three fail outputs are activated simultaneously with following output functionalities:

- FO1: Static fail output
- FO2: 1.25Hz, 50% (typ.) duty cycle, e.g. to generate an indicator signal

- FO3: 100Hz PWM, 20% (typ.) duty cycle, e.g. to generate a dimmed rear light from a break light.

Note: The duty cycle for FO3 can be configured via SPI option to 20%, 10%, 5% or 2.5%. Default value is 20%. See the register **FO_DC** for configuration.

12.1.1 General Purpose I/O Functionality of FO2 and FO3 as Alternate Function

In case that FO2 and FO3 are not used in the application, those pins can also be configured with an alternate function as high-voltage (VSHS related) General Purpose I/O pins.

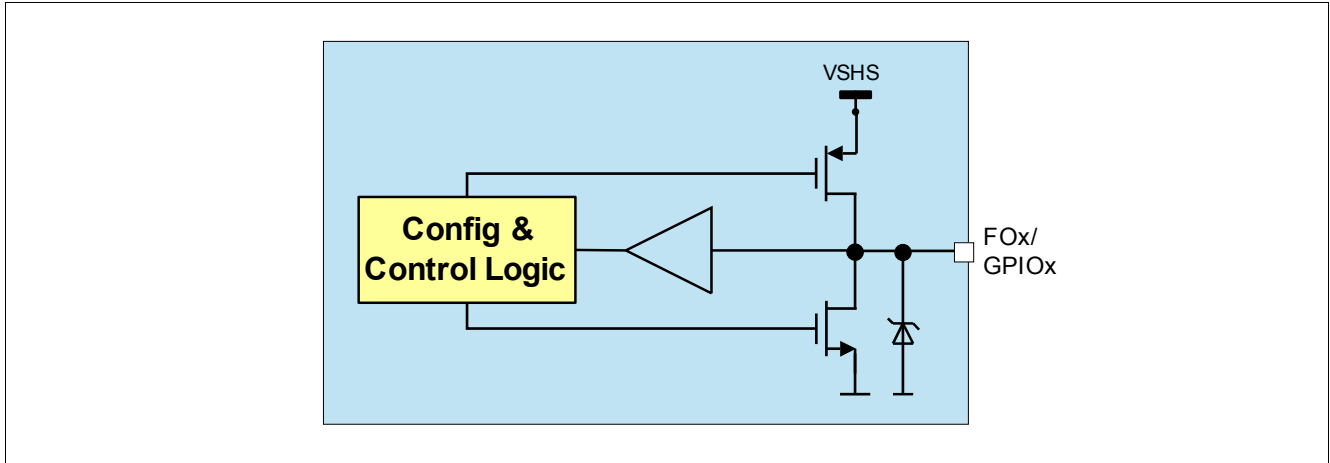

Figure 32 Simplified General Purpose I/O block diagram for FO2 and FO3/TEST

The pins are by default configured as FO pins. The configuration is done via the SPI register **GPIO_CTRL**. The alternate function can be:

- Wake Inputs: The detection threshold $V_{GPIO,th}$ is similar as for the WK inputs. The wake-up detection behavior is the same as for WKx pins. Wake events are stored and reported in **WK_STAT_2**.
- Low-Side Switches: The switch is able to drive currents of up to 10mA (see also $V_{GPIO,L1}$). It is self-protected with regards to current limitation. No other diagnosis is implemented.
- High-Side Switches: The switch is able to drive currents up to 10mA (see also $V_{GPIO,H1}$). It is self-protected with regards to current limitation. No other diagnosis is implemented.
- If configured as GPIO then the respective level at the pin will be shown in **WK_LVL_STAT** in SBC Normal and Stop Mode. This is also the case if configured as LS/HS and can serve as a feedback about the respective state. GPIO2 is shared with the TEST level bit.

Figure 33 describes the behavior of the FO/GPIO pins in their different configurations and SBC modes.

| Function | Normal Mode | Stop Mode | Sleep Mode | Fail-Safe Mode |
|----------|--------------|------------------------------|-----------------|----------------|
| FOx | configurable | keeps the state | keeps the state | active |
| WK | | wake capable | wake capable | OFF |
| HS | | as configured in Normal Mode | OFF | OFF |
| LS | | as configured in Normal Mode | OFF | OFF |

Figure 33 FO / GPIO behavior for the respective SBC modes

Note: In order to avoid unintentional entry of SBC Development Mode care must be taken that the level of FO3/TEST is HIGH during device power up and SBC Init Mode.

Note: The FOx drivers are supplied via VS. However, the GPIO HS switches (FO2, FO3/TEST) are supplied by VSHS

12.2 Electrical Characteristics

Table 19 Interrupt Output

$V_{SHS} = 5.5\text{ V to }28\text{ V}$; $T_j = -40\text{ °C to }+150\text{ °C}$; SBC Normal Mode; all voltages with respect to ground; positive current defined flowing into pin; unless otherwise specified.¹⁾

| Parameter | Symbol | Values | | | Unit | Note / Test Condition | Number |
|---|-----------------|--------|------|------|---------------|--|-----------|
| | | Min. | Typ. | Max. | | | |
| Pin FO1 | | | | | | | |
| FO1 low output voltage (active) | $V_{FO,L1}$ | – | – | 1.0 | V | $I_{FO} = 4\text{ mA}$ | P_14.2.1 |
| FO1 high output current (inactive) | $I_{FO,H}$ | 0 | – | 2 | μA | $V_{FO} = 28\text{ V}$ | P_14.2.2 |
| Pin FO2 | | | | | | | |
| FO2 side indicator frequency | f_{FO2SI} | 1.00 | 1.25 | 1.50 | Hz | ³⁾ | P_14.2.3 |
| FO2 side indicator duty cycle | d_{FO2SI} | – | 50 | – | % | ³⁾ | P_14.2.4 |
| Pin FO3/TEST²⁾ | | | | | | | |
| Pull-up Resistance at pin FO3/TEST | R_{TEST} | 2.5 | 5 | 10 | k Ω | $V_{TEST} = 0\text{ V}$; SBC Init Mode | P_14.2.5 |
| TEST Input Filter Time | t_{TEST} | – | 64 | – | μs | ³⁾ | P_14.2.6 |
| FO3 pulsed light frequency | f_{FO3PL} | 80 | 100 | 120 | Hz | ³⁾ | P_14.2.7 |
| FO3 pulsed light duty cycle | d_{FO3PL} | – | 20 | – | % | ³⁾⁴⁾ default setting | P_14.2.8 |
| Alternate FO2...3 | | | | | | | |
| Electrical Characteristics: GPIO | | | | | | | |
| GPIO low-side output voltage (active) | $V_{GPIOI,L1}$ | – | – | 1 | V | $I_{GPIO} = 10\text{ mA}$ | P_14.2.9 |
| GPIO low-side output voltage (active) | $V_{GPIOI,L2}$ | – | – | 5 | mV | ⁵⁾ $I_{GPIO} = 50\mu\text{A}$ | P_14.2.17 |
| GPIO high-side output voltage (active) | $V_{GPIOH,H1}$ | VSHS-1 | – | – | V | $I_{GPO} = -10\text{ mA}$ | P_14.2.10 |
| GPIO high-side output voltage (active) | $V_{GPIOH,H2}$ | VSHS-5 | – | – | mV | ⁵⁾ $I_{GPO} = -50\mu\text{A}$ | P_14.2.18 |
| GPIO input threshold voltage | $V_{GPIOI,th}$ | 1.5 | 2.5 | 3.5 | V | ⁶⁾ hysteresis included | P_14.2.11 |
| GPIO input threshold hysteresis | $V_{GPIOI,hys}$ | 100 | 400 | 700 | mV | ⁵⁾ | P_14.2.12 |
| GPIO low-side current limitation | $I_{GPIOI,max}$ | 10 | – | 30 | mA | $V_{GPIO} = 28\text{ V}$ | P_14.2.13 |
| GPIO high-side current limitation | $I_{GPIOH,max}$ | -45 | – | -10 | mA | $V_{GPIO} = 0\text{ V}$ | P_14.2.14 |

1) The FOx drivers are supplied via VS. However, the GPIO HS switches (FO2, FO3/TEST) are supplied by VSHS

Fail Outputs

- 2) The external capacitance on this pin must be limited to less than 10nF to ensure proper detection of SBC Development Mode and SBC User Mode operation.
- 3) Not subject to production test, tolerance defined by internal oscillator tolerance.
- 4) The duty cyclic is adjustable via the SPI bits **FO_DC**.
- 5) Not subject to production test, specified by design.
- 6) Applies also for TEST voltage input level

13 Supervision Functions

13.1 Reset Function

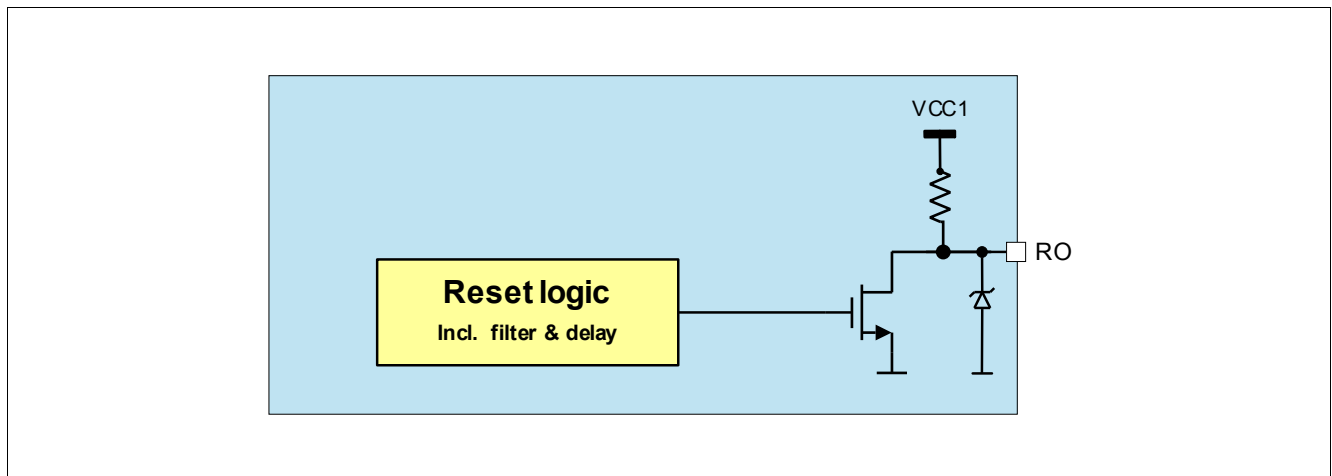

Figure 34 Reset Block Diagram

13.1.1 Reset Output Description

The reset output pin RO provides a reset information to the microcontroller, for example, in the event that the output voltage has fallen below the under voltage threshold $V_{RT1/2/3/4}$. In case of a reset event, the reset output RO is pulled to low after the filter time t_{RF} and stays low as long as the reset event is present plus a reset delay time t_{RD1} . When connecting the SBC to battery voltage, the reset signal remains LOW initially. When the output voltage V_{cc1} has reached the reset default threshold $V_{RT1,r}$, the reset output RO is released to HIGH after the reset delay time t_{RD1} . A reset can also occur due to a watchdog trigger failure. The reset threshold can be adjusted via SPI, the default reset threshold is $V_{RT1,f}$. The RO pin has an integrated pull-up resistor. In case reset is triggered, it will be pulled low for $V_{cc1} \geq 1V$ and for $V_S \geq V_{POR,f}$ (see also [Chapter 13.3](#)).

The timings for the RO triggering regarding VCC1 under voltage and watchdog trigger is shown in [Figure 35](#).

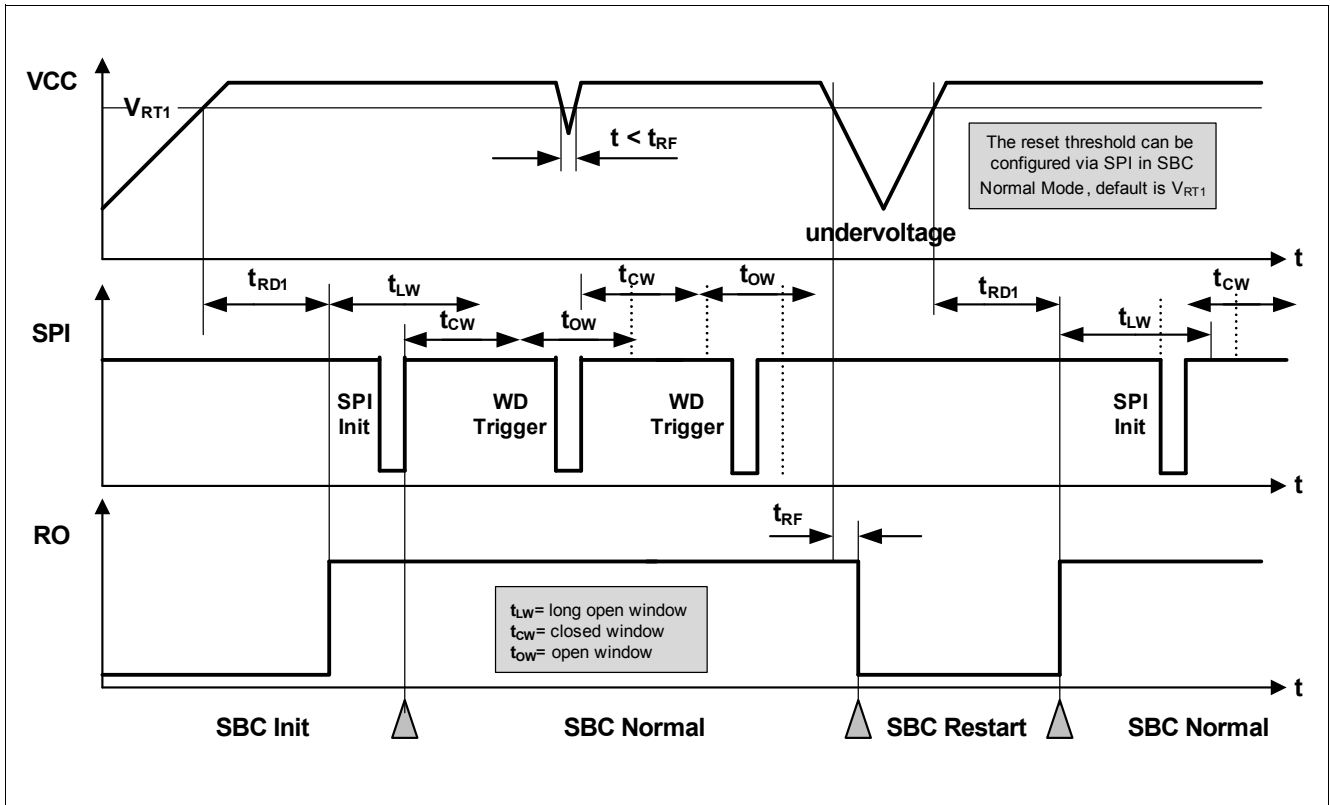

Figure 35 Reset Timing Diagram

13.1.2 Soft Reset Description

In SBC Normal and SBC Stop Mode, it is also possible to trigger a device internal reset via a SPI command in order to bring the SBC into a defined state in case of failures. In this case the microcontroller must send a SPI command and set the **MODE** bits to '11' in the **M_S_CTRL** register. As soon as this command becomes valid, the SBC is set back to SBC INIT Mode and all SPI registers are set to their default values (see SPI [Chapter 14.5](#) and [Chapter 14.6](#)).

Two different soft reset configurations are possible via the SPI bit **SOFT_RESET_RO**:

- The reset output (RO) is triggered when the soft reset is executed (default setting, the same reset delay time t_{RD1} applies)
- The reset output (RO) is not triggered when the soft reset is executed

Note: The device must be in SBC Normal Mode or SBC Stop Mode when sending this command. Otherwise, the command will be ignored.

13.2 Watchdog Function

The watchdog is used to monitor the software execution of the microcontroller and to trigger a reset if the microcontroller stops serving the watchdog due to a lock up in the software.

Two different types of watchdog functions are implemented and can be selected via the bit **WD_WIN**:

- Time-Out Watchdog (default value)
- Window Watchdog

The respective watchdog functions can be selected and programmed in SBC Normal Mode. The configuration stays unchanged in SBC Stop Mode.

Please refer to **Table 20** to match the SBC Modes with the respective watchdog modes.

Table 20 Watchdog Functionality by SBC Modes

| SBC Mode | Watchdog Mode | Remarks |
|--------------|------------------------------|--|
| INIT Mode | Starts with Long Open Window | Watchdog starts with Long Open Window after RO is released |
| Normal Mode | WD Programmable | Window Watchdog, Time-Out watchdog or switched OFF for SBC Stop Mode |
| Stop Mode | Watchdog is fixed or OFF | |
| Sleep Mode | OFF | SBC will start with Long Open Window when entering SBC Normal Mode. |
| Restart Mode | OFF | SBC will start with Long Open Window when entering SBC Normal Mode. |

The watchdog timing is programmed via SPI command. As soon as the watchdog is programmed, the timer starts with the new setting and the watchdog must be served. The watchdog is triggered by sending a valid SPI-write command to the watchdog configuration register. The trigger SPI command is executed when the Chip Select input (CSN) becomes HIGH.

When coming from SBC Init, SBC Restart Mode or in certain cases from SBC Stop Mode, the watchdog timer is always started with a long open window. The long open window ($t_{LW} = 200ms$) allows the microcontroller to run its initialization sequences and then to trigger the watchdog via SPI.

The watchdog timer period can be selected via the watchdog timing bit field (**WD_TIMER**) and is in the range of 10 ms to 1000 ms. This setting is valid for both watchdog types.

The following watchdog timer periods are available:

- WD Setting 1: 10ms
- WD Setting 2: 20ms
- WD Setting 3: 50ms
- WD Setting 4: 100ms
- WD Setting 5: 200ms
- WD Setting 6: 500ms
- WD Setting 7: 1000ms

In case of a watchdog reset, SBC Restart or SBC Fail-Safe Mode is entered according to the configuration and the SPI bits **WD_FAIL** are set. Once the RO goes HIGH again the watchdog immediately starts with a long open window the SBC enters automatically SBC Normal Mode.

In SBC Software Development Mode the watchdog is OFF and therefore no reset and interrupt are generated due to a watchdog failure.

Depending on the configuration, the **WD_FAIL** bits will be set after a watchdog trigger failure as follows:

- In case an incorrect WD trigger is received (triggering in the closed watchdog window or when the watchdog counter expires without a valid trigger) then the **WD_FAIL** bits will be increased (showing the number of incorrect WD triggers)
- For config 2: the bits can have the maximum value of '01'
- For config 1, 3 and 4: the bits can have the maximum value of '10'

The **WD_FAIL** bits are cleared automatically when following conditions apply:

- After a successful watchdog trigger
- When the watchdog is OFF: in SBC Stop Mode after successfully disabling it, in SBC Sleep Mode, or in SBC Fail-Safe Mode (except for a watchdog failure)

13.2.1 Time-Out Watchdog

The time-out watchdog is an easier and less secure watchdog than a window watchdog as the watchdog trigger can be done at any time within the configured watchdog timer period.

A correct watchdog service immediately results in starting a new watchdog timer period. Taking the tolerances of the internal oscillator into account leads to the safe trigger area as defined in [Figure 36](#).

If the time-out watchdog period elapses, a watchdog reset is created by setting the reset output RO low and the SBC switches to SBC Restart or SBC Fail-Safe Mode.

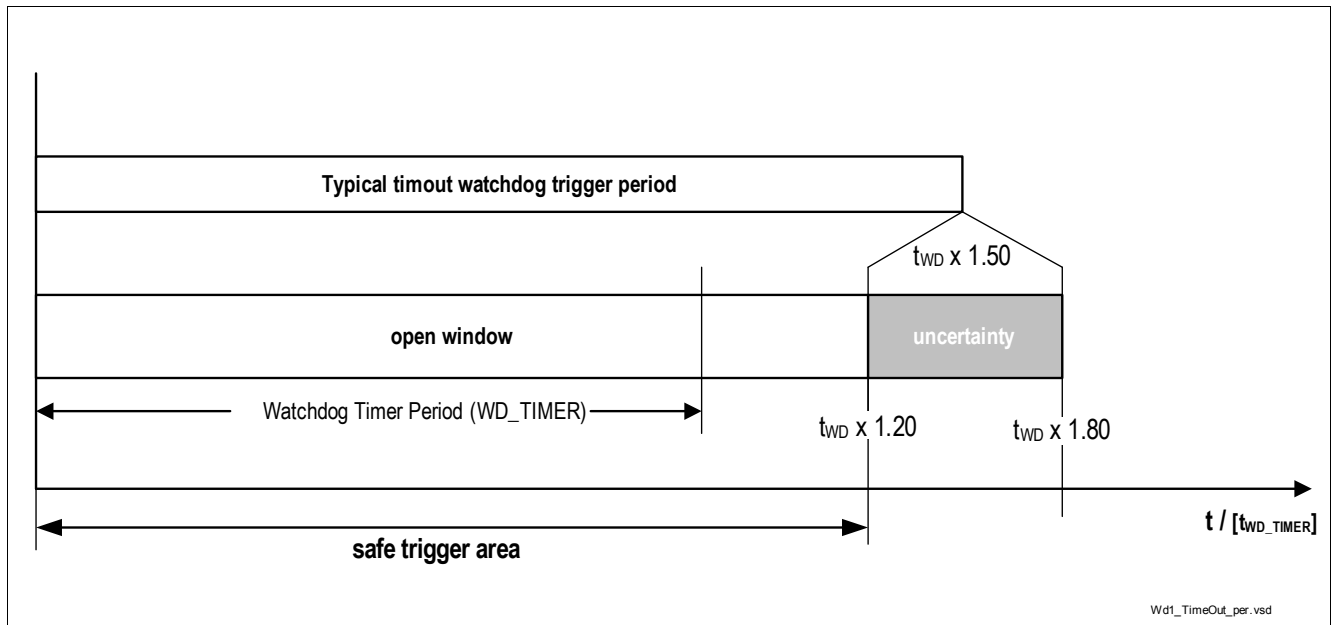

Figure 36 Time-out Watchdog Definitions

13.2.2 Window Watchdog

Compared to the time-out watchdog the characteristic of the window watchdog is that the watchdog timer period is divided between an closed and an open window. The watchdog must be triggered within the open window.

A correct watchdog trigger results in starting the window watchdog period by a closed window followed by an open window.

The watchdog timer period is at the same time the typical trigger time and defines the middle of the open window. Taking the oscillator tolerances into account leads to a safe trigger area of:

$$t_{WD} \times 0.72 < \text{safe trigger area} < t_{WD} \times 1.20.$$

The typical closed window is defined to a width of 60% of the selected window watchdog timer period. Taking the tolerances of the internal oscillator into account leads to the timings as defined in [Figure 37](#).

A correct watchdog service immediately results in starting the next closed window.

Should the trigger signal meet the closed window or should the watchdog timer period elapse, then a watchdog reset is created by setting the reset output RO low and the SBC switches to SBC Restart or SBC Fail-Safe Mode.

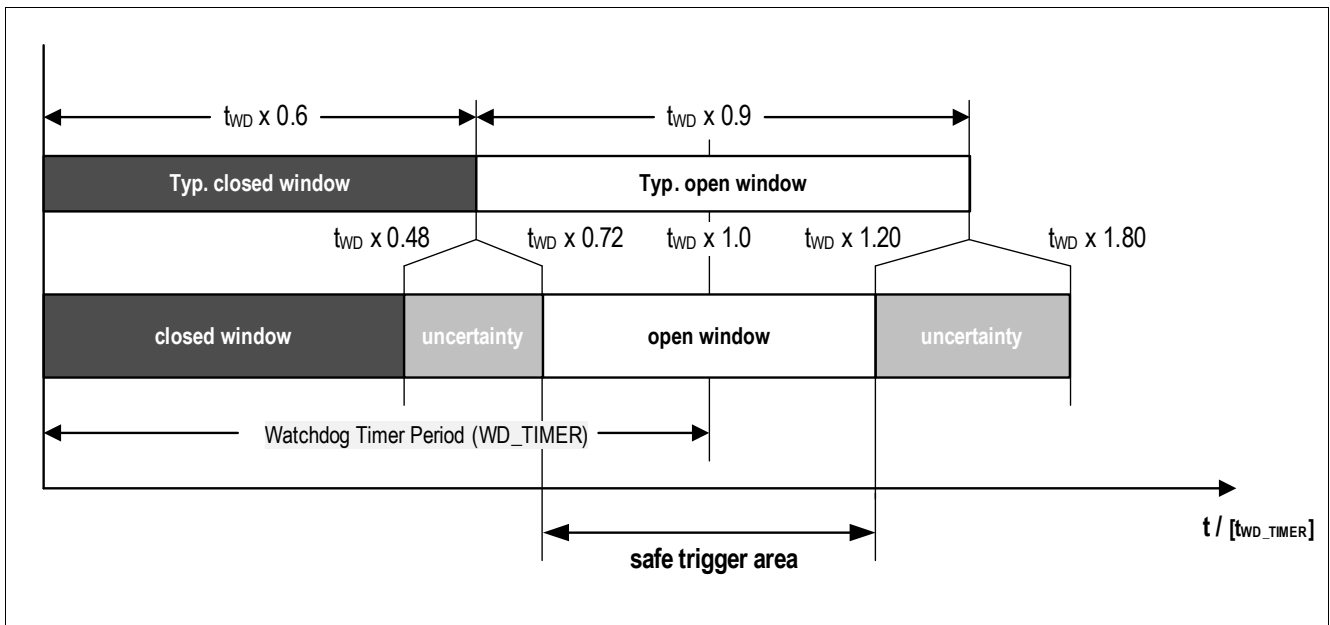

Figure 37 Window Watchdog Definitions

13.2.3 Watchdog Setting Check Sum

A check sum bit is part of the SPI command to trigger the watchdog and to set the watchdog setting.

The sum of the 8 data bits in the register WWD_CTRL needs to have even parity (see [Equation \(1\)](#)). This is realized by either setting the bit **CHECKSUM** to 0 or 1. If the check sum is wrong, then the SPI command is ignored, i.e. the watchdog is not triggered or the settings are not changed and the bit SPI_FAIL is set.

The checksum is calculated by taking all 8 data bits into account. The written value of the reserved bit 3 of the WWD_CTRL register is considered (even if read as '0' in the SPI output) for checksum calculation, i.e. if a 1 is written on the reserved bit position, then a 1 will be used in the checksum calculation.

(1)

$$CHKSUM = \text{Bit15} \oplus \dots \oplus \text{Bit8}$$

13.2.4 Watchdog during SBC Stop Mode

The watchdog can be disabled for SBC Stop Mode in SBC Normal Mode. For safety reasons, there is a special sequence to be followed in order to disable the watchdog as described in **Figure 38**. Two different SPI bits (**WD_STM_EN_0**, **WD_STM_EN_1**) in the registers **WK_CTRL_1** and **WD_CTRL** need to be set.

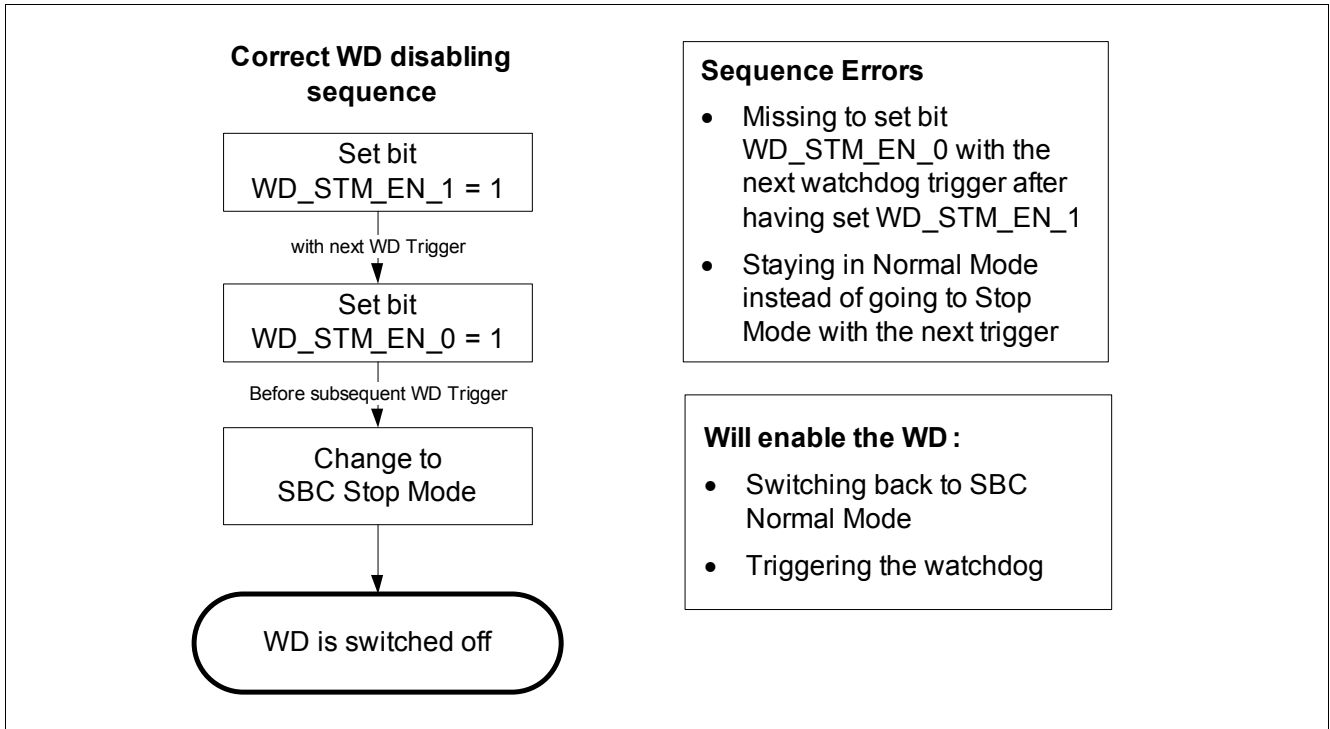

Figure 38 Watchdog disabling sequence in SBC Stop Mode

If a sequence error occurs, then the bit **WD_STM_EN_1** will be cleared and the sequence has to be started again. The watchdog can be enabled by triggering the watchdog in SBC Stop Mode or by switching back to SBC Normal Mode via SPI command. In both cases the watchdog will start with a long open window and the bits **WD_STM_EN_1** and **WD_STM_EN_0** are cleared. After the long open window the watchdog has to be served as configured in the **WD_CTRL** register.

*Note: The bit **WD_STM_EN_0** will be cleared automatically when the sequence is started and it was 1 before.*

13.2.5 Watchdog Start in SBC Stop Mode due to Bus Wake

In SBC Stop Mode the Watchdog can be disabled. In addition a feature is available which will start the watchdog with any BUS wake (CAN) during SBC Stop Mode. The feature is enabled by setting the bit **WD_EN_WK_BUS** = 1 (= default value after POR). The bit can only be changed in SBC Normal Mode and needs to be programmed before starting the watchdog disable sequence.

A wake on CAN will generate an interrupt and the RXD pin for CAN is pulled to low. By these signals the microcontroller is informed that the watchdog is started with a long open window. After the long open window the watchdog has to be served as configured in the **WD_CTRL** register.

To disable the watchdog again, the SBC needs to be switched to Normal Mode and the sequence needs to be sent again.

13.3 VS Power On Reset

At power up of the device, the VS Power on Reset is detected when $V_S > V_{POR,r}$ and the SPI bit **POR** is set to indicate that all SPI registers are set to POR default settings. VCC1 is starting up and the reset output will be kept LOW and will only be released once VCC1 has crossed $V_{RT1,r}$ and after t_{RD1} has elapsed.

In case $V_S < V_{POR,f}$, an device internal reset will be generated and the SBC is switched OFF and will restart in INIT mode at the next VS rising. This is shown in **Figure 39**.

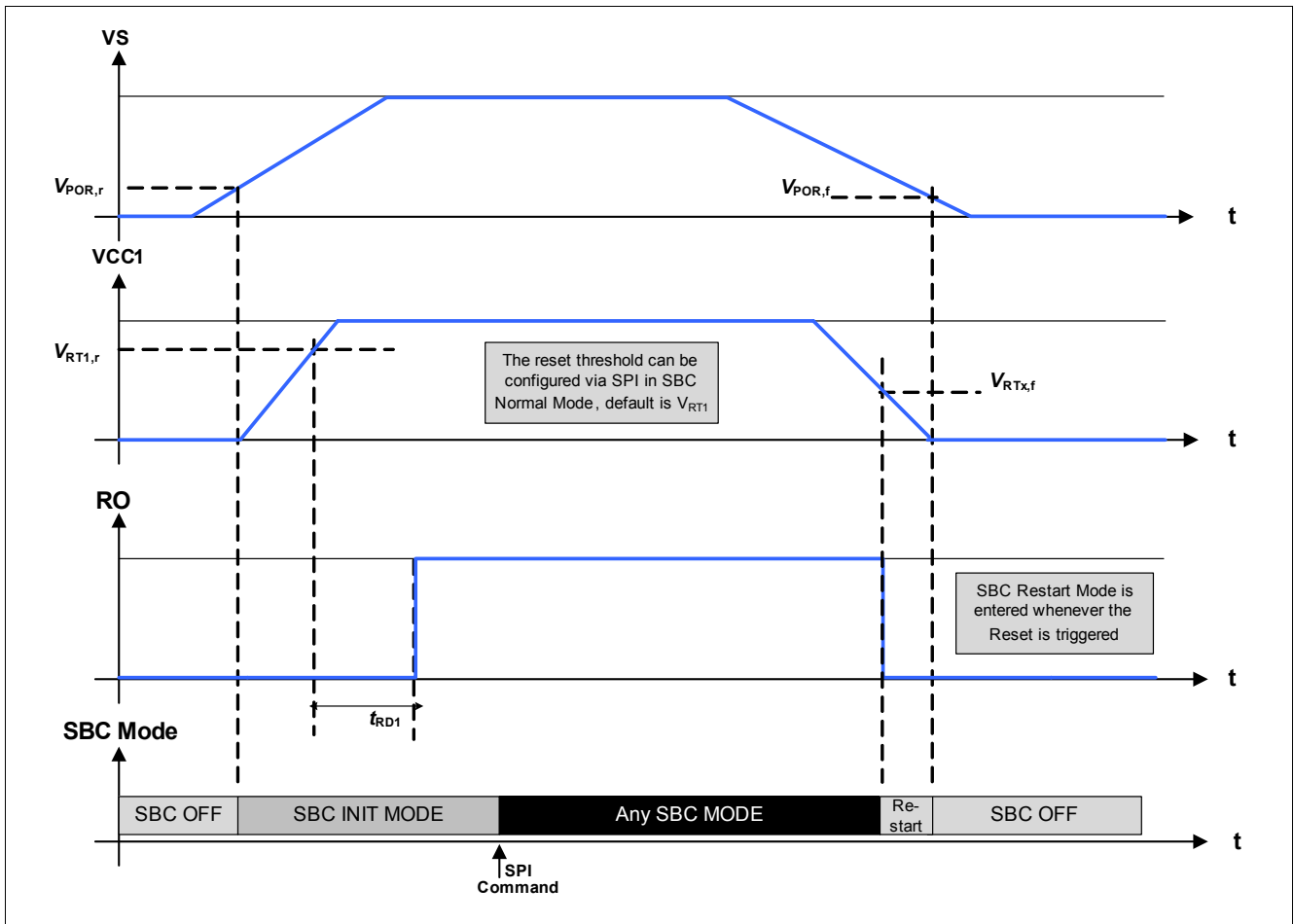

Figure 39 Ramp up / down example of Supply Voltage

13.4 Under Voltage VS and VSHS

If the supply voltage VS reaches the under voltage threshold $V_{S,UV}$ then the SBC does the following measures:

- SPI bit **VS_UV** is set. No other error bits are set. The bit can be cleared once the condition is not present anymore,
- The VCC1 short circuit protection becomes inactive (see [Chapter 13.7](#)). However, the thermal protection of the device remains active.

If the under voltage threshold is exceeded (VS rising) then functions will be automatically enabled again.

If the supply voltage VSHS passes below the under voltage threshold ($V_{SHS,UVD}$) the SBC does the following measures:

- HS1...4 are acting accordingly to the SPI setting (see [Chapter 8](#))
- SPI bit **VSHS_UV** is set. No other error bits are set. The bit can be cleared once the condition is not present anymore,
- VCC1, VCC2, WKx and CAN are not affected by VSHS under voltage

13.5 Over Voltage VSHS

If the supply voltage VSHS reaches the over voltage threshold ($V_{SHS,OVD}$) the SBC triggers the following measures:

- HS1...4 are acting accordingly to the SPI setting (see [Chapter 8](#))
- SPI bit **VSHS_OV** is set. No other error bits are set. The bit can be cleared once the condition is not present anymore,
- VCC1, VCC2, WKx and CAN are not affected by VS over voltage

13.6 VCC1 Over-/ Under Voltage and Under Voltage Prewarning

13.6.1 VCC1 Under Voltage and Under Voltage Prewarning

A first-level voltage detection threshold is implemented as a prewarning for the microcontroller. The prewarning event is signaled with the bit **VCC1_WARN**. No other actions are taken.

As described in [Chapter 13.1](#) and [Figure 40](#), a reset will be triggered (RO pulled 'low') when the V_{CC1} output voltage falls below the selected under voltage threshold (V_{RTx}). The bit **VCC1_UV** is set and the SBC will enter SBC Restart Mode.

*Note: The **VCC1_WARN** or **VCC1_UV** bits are not set in Sleep Mode as $V_{CC1} = 0V$ in this case*

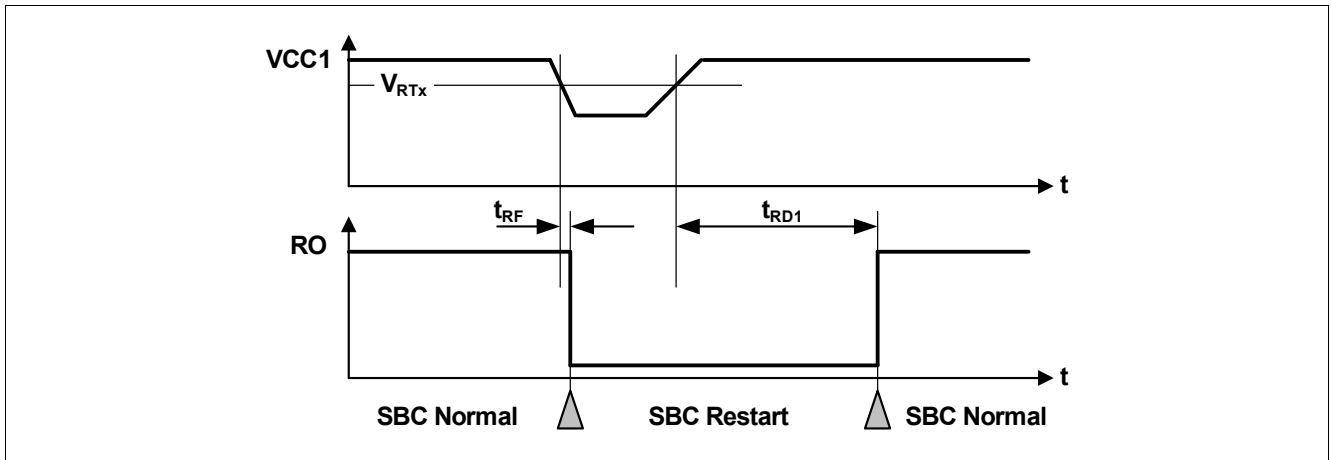

Figure 40 VCC1 Under Voltage Timing Diagram

An additional safety mechanism is implemented to avoid repetitive VCC1 under voltage resets due to high dynamic loads on VCC1:

- A counter is increased for every consecutive VCC1 under voltage event (regardless on the selected reset threshold),
- The counter is active in SBC Init-, Normal-, and Stop Mode,
- For $V_S < V_{S,UV}$ the counter will be stopped in SBC Normal Mode (i.e. the VS UV comparator is always enabled in SBC Normal Mode),
- A 4th consecutive VCC1 under voltage event will lead to SBC Fail-Safe Mode entry and to setting the bit **VCC1_UV_FS**
- This counter is cleared:
 - when SBC Fail-Safe Mode is entered,
 - when the bit **VCC1_UV** is cleared,
 - when a Soft Reset is triggered.

Note: It is recommended to clear the VCC1_UV bit once it was set and detected.

13.6.2 VCC1 Over Voltage

For fail-safe reasons a configurable VCC1 over voltage detection feature is implemented. It is active in SBC Init-, Normal-, and Stop Mode.

In case the $V_{CC1,OV,r}$ threshold is crossed, the SBC triggers following measures depending on the configuration:

- The bit **VCC1_OV** is always set;
- If the bit **VCC1_OV_RST** is set and **CFGP** = '1', then SBC Restart Mode is entered. The FOx outputs are activated. After the reset delay time (t_{RD1}), the SBC Restart Mode is left and SBC Normal Mode is resumed even if the VCC1 over voltage event is still present (see also Figure 41). The **VCC1_OV_RST** bit is cleared automatically;
- If the bit **VCC1_OV_RST** is set and **CFGP** = '0', then SBC Fail-Safe Mode is entered and FOx outputs are activated.

*Note: In case the VCC1 output current in SBC STOP Mode is below the active peak threshold ($I_{VCC1,I,peak}$) it should be considered to clear the bit **VCC1_OV_RST** before entering SBC Stop Mode to avoid unintentional SBC Restart or Fail-Safe Mode entry and to ignore the **VCC1_OV** bit due to external noise.*

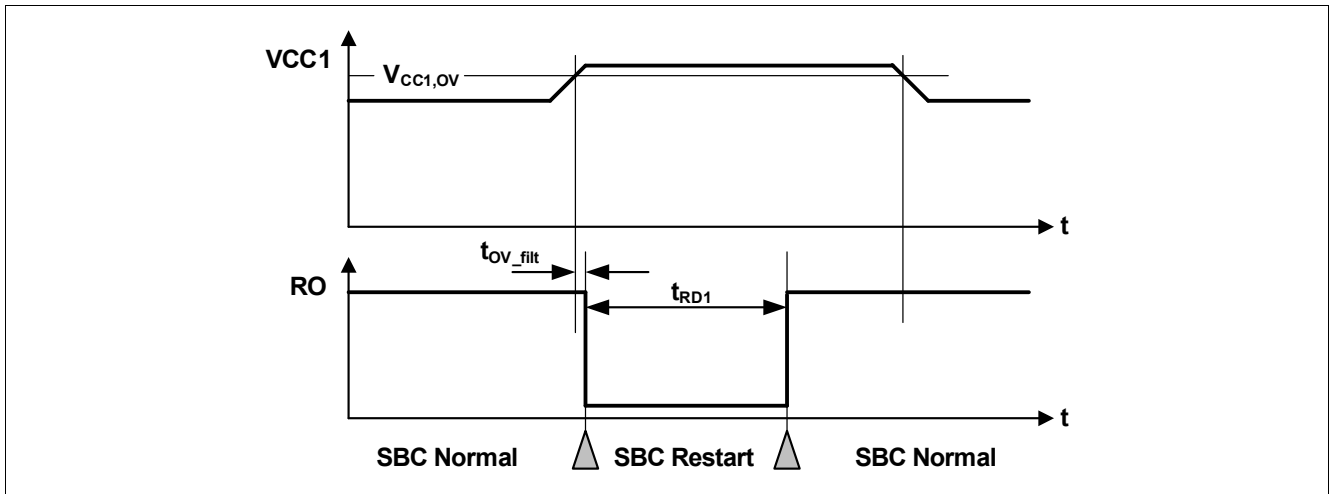

Figure 41 VCC1 Over Voltage Timing Diagram

13.7 VCC1 Short Circuit Diagnostics

The short circuit protection feature for V_{CC1} is implemented as follows (V_S needs to be higher than $V_{S,UV}$):

- If V_{CC1} is not above the V_{RTX} within $t_{VCC1,SC}$ after device power up or after waking from SBC Sleep Mode then the SPI bit **VCC1_SC** bit is set, V_{CC1} is turned OFF, the FOx pins are enabled, **FAILURE** is set and SBC Fail-Safe Mode is entered. The SBC can be activated again via wake on CAN, WKx.
- The same behavior applies, if V_{CC1} falls below V_{RTX} for more than $t_{VCC1,SC}$.

Note: The **VCC1_SC** flag is not set during power up of V_{CC1} .

13.8 VCC2 Undervoltage and VCAN Undervoltage

An undervoltage warning is implemented for V_{CC2} and V_{CAN} as follows:

- V_{CC2} undervoltage Detection: In case V_{CC2} will drop below the $V_{CC2,UV,f}$ threshold, then the SPI bit **VCC2_UV** is set and can be only cleared via SPI.
- V_{CAN} undervoltage Detection: In case *the voltage on* V_{CAN} will drop below the $V_{CAN,UV}$ threshold, then the SPI bit **VCAN_UV** is set and can be only cleared via SPI.

Note: The **VCC2_UV** flag is not set during turn-on or turn-off of V_{CC2} .

13.9 Thermal Protection

Three independent and different thermal protection features are implemented in the SBC according to the system impact:

- Individual thermal shutdown of specific blocks
- Temperature prewarning of main microcontroller supply VCC1
- SBC thermal shutdown due to VCC1 over temperature

13.9.1 Individual Thermal Shutdown

As a first-level protection measure the output stages VCC2, CAN, and HSx are independently switched OFF if the respective block reaches the temperature threshold T_{JTSD1} . Then the **TSD1** bit is set. This bit can only be cleared via SPI once the overtemperature is not present anymore. Independent of the SBC Mode the thermal shutdown protection is only active if the respective block is ON.

The respective modules behave as follows:

- VCC2: Is switched to OFF and the control bits **VCC2_ON** are cleared. The status bit **VCC2_OT** is set. Once the over temperature condition is not present anymore, then VCC2 has to be configured again by SPI.
- CAN: The transmitter is disabled and stays in CAN Normal Mode acting like CAN Receive only mode. The status bits **CAN_FAIL** = '01' are set. Once the over temperature condition is not present anymore, then the CAN transmitter is automatically switched on.
- HSx: If one or more HSx switches reach the TSD1 threshold, then all HSx switches are turned OFF and the control bits for HSx are cleared (see registers **HS_CTRL1** and **HS_CTRL2**). The status bits HSx_OC_OT are set (see register **HS_OC_OT_STAT**). Once the over temperature condition is not present anymore, then HSx has to be configured again by SPI.

Note: The diagnosis bits are not cleared automatically and have to be cleared via SPI once the overtemperature condition is not present anymore.

13.9.2 Temperature Prewarning

As a next level of thermal protection a temperature prewarning is implemented if the main supply VCC1 reaches the thermal prewarning temperature threshold T_{jPW} . Then the status bit **TPW** is set. This bit can only be cleared via SPI once the overtemperature is not present anymore. Independent of the SBC Mode the thermal prewarning is only active if the VCC1 is ON.

13.9.3 SBC Thermal Shutdown

As a highest level of thermal protection a temperature shutdown of the SBC is implemented if the main supply VCC1 reaches the thermal shutdown temperature threshold T_{jTSD2} . Once a TSD2 event is detected SBC Fail-Safe Mode is entered for t_{TSD2} to allow the device to cool down. After this time has expired, the SBC will automatically change via SBC Restart Mode to SBC Normal Mode (see also [Chapter 5.1.6](#)).

When a TSD2 event is detected, then the status bit **TSD2** is set. This bit can only be cleared via SPI in SBC Normal Mode once the overtemperature is not present anymore. Independent of the SBC Mode the thermal shutdown is only active if VCC1 is ON.

13.10 Electrical Characteristics
Table 21 Electrical Specification

$V_S = 5.5\text{ V to }28\text{ V}$; $T_j = -40\text{ °C to }+150\text{ °C}$; SBC Normal Mode; all voltages with respect to ground; positive current defined flowing into pin; unless otherwise specified.

| Parameter | Symbol | Values | | | Unit | Note / Test Condition | Number |
|--|----------------|----------------------|------|--------------------------|---------------|---|------------|
| | | Min. | Typ. | Max. | | | |
| VCC1 Monitoring; VCC1 = 5.0V Version | | | | | | | |
| Undervoltage Prewarning Threshold Voltage PW,f | $V_{PW,f}$ | 4.6 | 4.7 | 4.85 | V | VCC1 falling, SPI bit is set | P_15.10.1 |
| Reset Threshold Voltage RT1,f | $V_{RT1,f}$ | 4.5 | 4.6 | 4.75 | V | default setting; VCC1 falling | P_15.10.3 |
| Reset Threshold Voltage RT1,r | $V_{RT1,r}$ | 4.6 | 4.7 | 4.85 | V | default setting; VCC1 rising | P_15.10.4 |
| Reset Threshold Voltage RT2,f | $V_{RT2,f}$ | 3.75 | 3.9 | 4.05 | V | VCC1 falling | P_15.10.5 |
| Reset Threshold Voltage RT2,r | $V_{RT2,r}$ | 3.85 | 4.0 | 4.15 | V | VCC1 rising | P_15.10.6 |
| Reset Threshold Voltage RT3,f | $V_{RT3,f}$ | 3.15 | 3.3 | 3.45 | V | $V_S \geq 4\text{ V}$; VCC1 falling | P_15.10.7 |
| Reset Threshold Voltage RT3,r | $V_{RT3,r}$ | 3.25 | 3.4 | 3.55 | V | $V_S \geq 4\text{ V}$; VCC1 rising | P_15.10.8 |
| Reset Threshold Voltage RT4,f | $V_{RT4,f}$ | 2.4 | 2.65 | 2.8 | V | $V_S \geq 4\text{ V}$; VCC1 falling | P_15.10.9 |
| Reset Threshold Voltage RT4,r | $V_{RT4,r}$ | 2.5 | 2.75 | 2.9 | V | $V_S \geq 4\text{ V}$; VCC1 rising | P_15.10.10 |
| Reset Threshold Hysteresis | $V_{RT,hys}$ | 50 | 100 | 200 | mV | – | P_15.10.11 |
| VCC1 Over Voltage Detection Threshold Voltage | $V_{CC1,OV,r}$ | 5.2 | – | 5.5 | V | ¹⁾⁵⁾ rising VCC1 | P_15.10.50 |
| VCC1 Short to GND Filter Time | $t_{VCC1,SC}$ | – | 4 | – | ms | ³⁾ | P_15.10.12 |
| Reset Generator; Pin RO | | | | | | | |
| Reset Low Output Voltage | $V_{RO,L}$ | – | 0.2 | 0.4 | V | $I_{RO} = 1\text{ mA}$ for $V_{CC1} \geq 1\text{ V}$ & $V_S \geq V_{POR,f}$ | P_15.10.14 |
| Reset High Output Voltage | $V_{RO,H}$ | $0.8 \times V_{CC1}$ | – | $V_{CC1} + 0.3\text{ V}$ | V | $I_{RO} = -20\text{ }\mu\text{A}$ | P_15.10.15 |
| Reset Pull-up Resistor | R_{RO} | 10 | 20 | 40 | k Ω | $V_{RO} = 0\text{ V}$ | P_15.10.16 |
| Reset Filter Time | t_{RF} | 4 | 10 | 26 | μs | ³⁾ $V_{CC1} < V_{RT1x}$ to RO = L see also Chapter 13.3 | P_15.10.17 |
| Reset Delay Time | t_{RD1} | 1.5 | 2 | 2.5 | ms | ^{2) 3)} | P_15.10.18 |

Table 21 Electrical Specification (cont'd)

$V_S = 5.5\text{ V to }28\text{ V}$; $T_j = -40\text{ °C to }+150\text{ °C}$; SBC Normal Mode; all voltages with respect to ground; positive current defined flowing into pin; unless otherwise specified.

| Parameter | Symbol | Values | | | Unit | Note / Test Condition | Number |
|--|-------------------|--------|------|------|------|---|------------|
| | | Min. | Typ. | Max. | | | |
| VCC2 Monitoring | | | | | | | |
| VCC2 Undervoltage Threshold Voltage (falling) | $V_{CC2,UV,f}$ | 4.5 | – | 4.75 | V | VCC2 falling | P_15.10.19 |
| VCC2 Undervoltage Threshold Voltage (rising) | $V_{CC2,UV,r}$ | 4.6 | – | 4.9 | V | VCC2 rising | P_15.10.77 |
| V_{CC2} Undervoltage detection hysteresis | $V_{CC2,UV,hys}$ | 20 | 100 | 250 | mV | – | P_15.10.20 |
| VCAN Monitoring | | | | | | | |
| CAN Supply under voltage detection threshold | V_{CAN_UV} | 4.45 | – | 4.85 | V | CAN Normal Mode, hysteresis included; | P_15.10.23 |
| Watchdog Generator | | | | | | | |
| Long Open Window | t_{LW} | – | 200 | – | ms | ³⁾ | P_15.10.24 |
| Internal Oscillator | f_{CLKSBC} | 0.8 | 1.0 | 1.2 | MHz | – | P_15.10.25 |
| Minimum Waiting time during SBC Fail-Safe Mode | | | | | | | |
| Min. waiting time Fail-Safe | $t_{FS,min}$ | – | 100 | – | ms | ³⁾⁴⁾ | P_15.10.75 |
| Power-on Reset, Over / Under Voltage Protection | | | | | | | |
| VS Power on reset rising | $V_{POR,r}$ | – | | 4.5 | V | VS increasing | P_15.10.26 |
| VS Power on reset falling | $V_{POR,f}$ | – | | 3 | V | VS decreasing | P_15.10.27 |
| VS Under Voltage Detection Threshold | $V_{S,UV}$ | 5.3 | – | 6.0 | V | Supply UV supervision for VCC1 SC detection; hysteresis included | P_15.10.13 |
| VSHS Over Voltage Detection Threshold | $V_{SHS,OVD}$ | 20 | | 22 | V | Supply OV supervision for HSx; hysteresis included | P_15.10.28 |
| VSHS Over Voltage Detection hysteresis | $V_{SHS,OVD,hys}$ | – | 500 | – | mV | ⁵⁾ | P_15.10.29 |
| VSHS Under Voltage Detection Threshold | $V_{SHS,UVD}$ | 4.8 | | 5.5 | V | Supply UV supervision for HSx, and HS of GPIOx; hysteresis included | P_15.10.30 |
| VSHS Under Voltage Detection hysteresis | $V_{SHS,UVD,hys}$ | – | 200 | – | mV | ⁵⁾ | P_15.10.31 |

Table 21 Electrical Specification (cont'd)

$V_S = 5.5\text{ V to }28\text{ V}$; $T_j = -40\text{ °C to }+150\text{ °C}$; SBC Normal Mode; all voltages with respect to ground; positive current defined flowing into pin; unless otherwise specified.

| Parameter | Symbol | Values | | | Unit | Note / Test Condition | Number |
|---|----------------|--------|------|------|------|-----------------------|------------|
| | | Min. | Typ. | Max. | | | |
| Over Temperature Shutdown⁵⁾ | | | | | | | |
| Thermal Prewarning Temperature | T_{jPW} | 125 | 145 | 165 | °C | | P_15.10.32 |
| Thermal Shutdown TSD1 | T_{jTSD1} | 165 | 185 | 200 | °C | | P_15.10.33 |
| Thermal Shutdown TSD2 | T_{jTSD2} | 165 | 185 | 200 | °C | | P_15.10.34 |
| Thermal Shutdown hysteresis | $T_{jTSD,hys}$ | – | 25 | – | °C | | P_15.10.68 |
| Deactivation time after thermal shutdown TSD2 | t_{TSD2} | – | 1 | – | s | ³⁾ | P_15.10.35 |

1) It is ensured that the threshold $V_{CC1,OV,r}$ is always higher than the highest regulated V_{CC1} output voltage $V_{CC1,out42}$.

2) The reset delay time will start when VCC1 crosses above the selected V_{rtx} threshold

3) Not subject to production test, tolerance defined by internal oscillator tolerance.

4) This time applies for all failure entries except a device thermal shutdown (TSD2 has a typ. 1s waiting time t_{TSD2})

5) Not subject to production test, specified by design.

14 Serial Peripheral Interface

14.1 SPI Block Description

The 16-bit wide Control Input Word is read via the data input SDI, which is synchronized with the clock input CLK provided by the microcontroller. The output word appears synchronously at the data output SDO (see [Figure 42](#)). The transmission cycle begins when the chip is selected by the input CSN (Chip Select Not), LOW active. After the CSN input returns from LOW to HIGH, the word that has been read is interpreted according to the content. The SDO output switches to tristate status (high impedance) at this point, thereby releasing the SDO bus for other use. The state of SDI is shifted into the input register with every falling edge on CLK. The state of SDO is shifted out of the output register after every rising edge on CLK. The SPI of the SBC is not daisy chain capable.

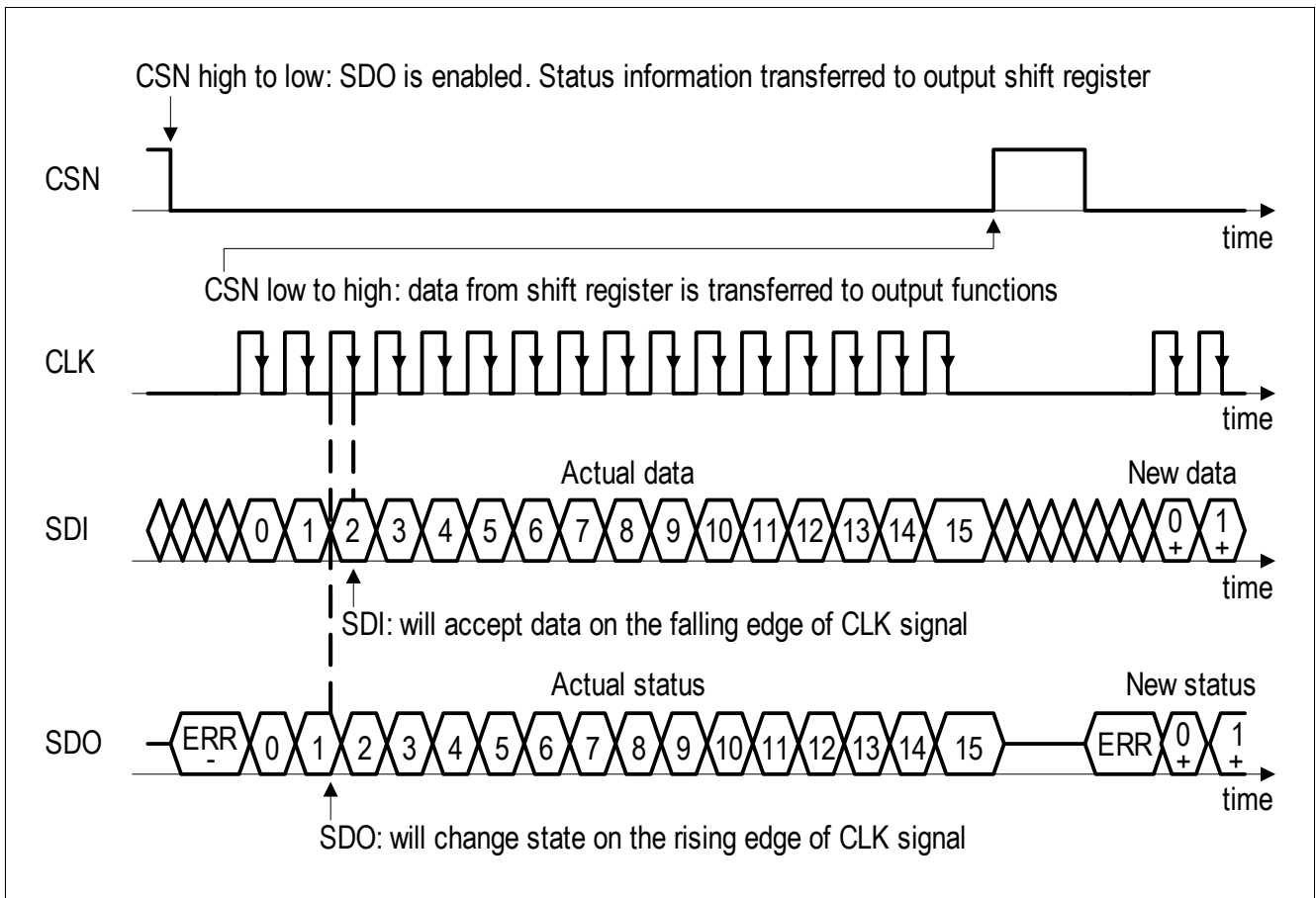

Figure 42 SPI Data Transfer Timing (note the reversed order of LSB and MSB shown in this figure compared to the register description)

14.2 Failure Signalization in the SPI Data Output

When the microcontroller sends a wrong SPI command to the SBC, the SBC ignores the information. Wrong SPI commands are either invalid SBC mode commands or commands which are prohibited by the state machine to avoid undesired device or system states (see below). In this case the diagnosis bit '**SPI_FAIL**' is set and the SPI Write command is ignored (mostly no partial interpretation). This bit can be only reset by actively clearing it via a SPI command.

Invalid SPI Commands leading to **SPI_FAIL are listed below:**

- Illegal state transitions: Going from SBC Stop to SBC Sleep Mode. In this case the SBC enters in addition the SBC Restart Mode;
Trying to go to SBC Stop or SBC Sleep mode from SBC Init Mode. In this case SBC Normal Mode is entered;
- Uneven parity in the data bit of the **WD_CTRL** register. In this case the watchdog trigger is ignored or the new watchdog settings are ignored respectively;
- In SBC Stop Mode: attempting to change any SPI settings, e.g. changing the watchdog configuration, PWM settings and HS configuration settings during SBC Stop Mode, etc.;
the SPI command is ignored in this case;
only WD trigger, returning to Normal Mode, triggering a SBC Soft Reset, and Read & Clear status registers commands are valid SPI commands in SBC Stop Mode;
- When entering SBC Stop Mode and **WK_STAT_1** and **WK_STAT_2** are not cleared; **SPI_FAIL** will not be set but the INT pin will be triggered;
- Changing from SBC Stop to Normal Mode and changing the other bits of the **M_S_CTRL** register. The other modifications will be ignored;
- SBC Sleep Mode: attempt to go to Sleep Mode when all bits in the **BUS_CTRL_1** and **WK_CTRL_2** registers are cleared. In this case the **SPI_FAIL** bit is set and the SBC enters Restart Mode.
Even though the Sleep Mode command is not entered in this case, the rest of the command (e.g. modifying VCC2) is executed and the values stay unchanged during SBC Restart Mode;
Note: At least one wake source must be activated in order to avoid a deadlock situation in SBC Sleep Mode, i.e. the SBC would not be able to wake up anymore.
If the only wake source is a timer and the timer is OFF then the SBC will wake immediately from Sleep Mode and enter Restart Mode;
No failure handling is done for the attempt to go to SBC STOP Mode when all bits in the registers **BUS_CTRL_1** and **WK_CTRL_2** are cleared because the microcontroller can leave this mode via SPI;
- Attempt to enter SBC Sleep Mode if **WK_MEAS** is set to '1' and only **WK1_EN** or **WK2_EN** are set as wake sources. Also in this case the **SPI_FAIL** bit is set and the SBC enters Restart Mode;
- Setting a longer or equal on-time than the timer period of the respective timer;
- SDI stuck at HIGH or LOW, e.g. SDI received all '0' or all '1';

Note: There is no SPI fail information for unused addresses.

Signalization of the ERR Flag (high active) in the SPI Data Output (see [Figure 42](#)):

The ERR flag presents an additional diagnosis possibility for the SPI communication. The ERR flag is being set for following conditions:

- in case the number of received SPI clocks is not 0 or 16,
- in case RO is LOW and SPI frames are being sent at the same time.

Note: In order to read the SPI ERR flag properly, CLK must be low when CSN is triggered, i.e. the ERR bit is not valid if the CLK is high on a falling edge of CSN

The number of received SPI clocks is not 0 or 16:

The number of received input clocks is supervised to be 0- or 16 clock cycles and the input word is discarded in case of a mismatch (0 clock cycle to enable ERR signalization). The error logic also recognizes if CLK was high during CSN edges. Both errors - 0 bit and 16 bit CLK mismatch or CLK high during CSN edges - are flagged in the following SPI output by a "HIGH" at the data output (SDO pin, bit ERR) before the first rising edge of the clock is received. The complete SPI command is ignored in this case.

RO is LOW and SPI frames are being sent at the same time:

The ERR flag will be set when the RO pin is triggered (during SBC Restart) and SPI frames are being sent to the SBC at the same time. The behavior of the ERR flag will be signalized at the next SPI command for below conditions:

- if the command begins when RO is HIGH and it ends when RO is LOW,
- if a SPI command will be sent while RO is LOW,
- If a SPI command begins when RO is LOW and it ends when RO is HIGH.

and the SDO output will behave as follows:

- always when RO is LOW then SDO will be HIGH,
- when a SPI command begins with RO is LOW and ends when RO is HIGH, then the SDO should be ignored because wrong data will be sent.

Note: It is possible to quickly check for the ERR flag without sending any data bits. i.e. only the CSN is pulled low and SDO is observed - no SPI Clocks are sent in this case

Note: The ERR flag could also be set after the SBC has entered SBC Fail-Safe Mode because the SPI communication is stopped immediately.

14.3 SPI Programming

For the TLE9260QX, 7 bits are used for the address selection (BIT6...0). Bit 7 is used to decide between Read Only and Read & Clear for the status bits, and between Write and Read Only for configuration bits. For the actual configuration and status information, 8 data bits (BIT15...8) are used.

Writing, clearing and reading is done byte wise. The SPI status bits are not cleared automatically and must be cleared by the microcontroller, e.g. if the TSD2 was set due to over temperature. The configuration bits will be partially automatically cleared by the SBC - please refer to the individual registers description for detailed information. During SBC Restart Mode the SPI communication is ignored by the SBC, i.e. it is not interpreted.

There are two types of SPI registers:

- Control registers: Those are the registers to configure the SBC, e.g. SBC mode, watchdog trigger, etc
- Status registers: Those are the registers where the status of the SBC is signalled, e.g. wake events, warnings, failures, etc.

For the status registers, the requested information is given in the same SPI command in DO.

For the control registers, also the status of the respective byte is shown in the same SPI command. However, if the setting is changed this is only shown with the next SPI command (it is only valid after CSN high) of the same register.

The SBC status information from the SPI status registers, is transmitted in a compressed way with each SPI response on SDO in the so called Status Information Field register (see also [Figure 43](#)). The purpose of this register is to quickly signal the information to the microcontroller if there was a change in one of the SPI status registers. In this way, the microcontroller does not need to read constantly all the SPI status registers but only those registers, which were changed.

Each bit in the Status Information Field represents a SPI status register (see [Table 22](#)). As soon as one bit is set in one of the status registers, then the respective bit in the Status Information Field register will be set. The register [WK_LVL_STAT](#) is not included in the status Information field. This is listed in [Table 22](#).

For Example if bit 0 in the Status Information Field is set to 1, one or more bits of the register 100 0001 ([SUP_STAT_1](#)) is set to 1. Then this register needs to be read in a second SPI command. The bit in the Status Information Field will be set to 0 when all bits in the register 100 0001 are set back to 0.

Table 22 Status Information Field

| Bit in Status Information Field | Corresponding Address Bit | Status Register Description |
|---------------------------------|---------------------------|---|
| 0 | 100 0001 | SUP_STAT_1: Supply Status -VSHS fail, VCCx fail, POR |
| 1 | 100 0010 | THERM_STAT: Thermal Protection Status |
| 2 | 100 0011 | DEV_STAT: Device Status - Mode before Wake, WD Fail, SPI Fail, Failure |
| 3 | 100 0100 | BUS_STAT: Bus Failure Status: CAN; |
| 4 | 100 0110 | WK_STAT_1, WK_STAT_2: Wake Source Status; Status bit is set as combinational OR of both registers |
| 5 | 100 0000 | SUP_STAT_2:VCC1_WARN/OV |
| 6 | 101 0100 | HS_OC_OT_STAT: High-Side Over Load Status |
| 7 | 101 0101 | HS_OL_STAT: High-Side Open Load Status |

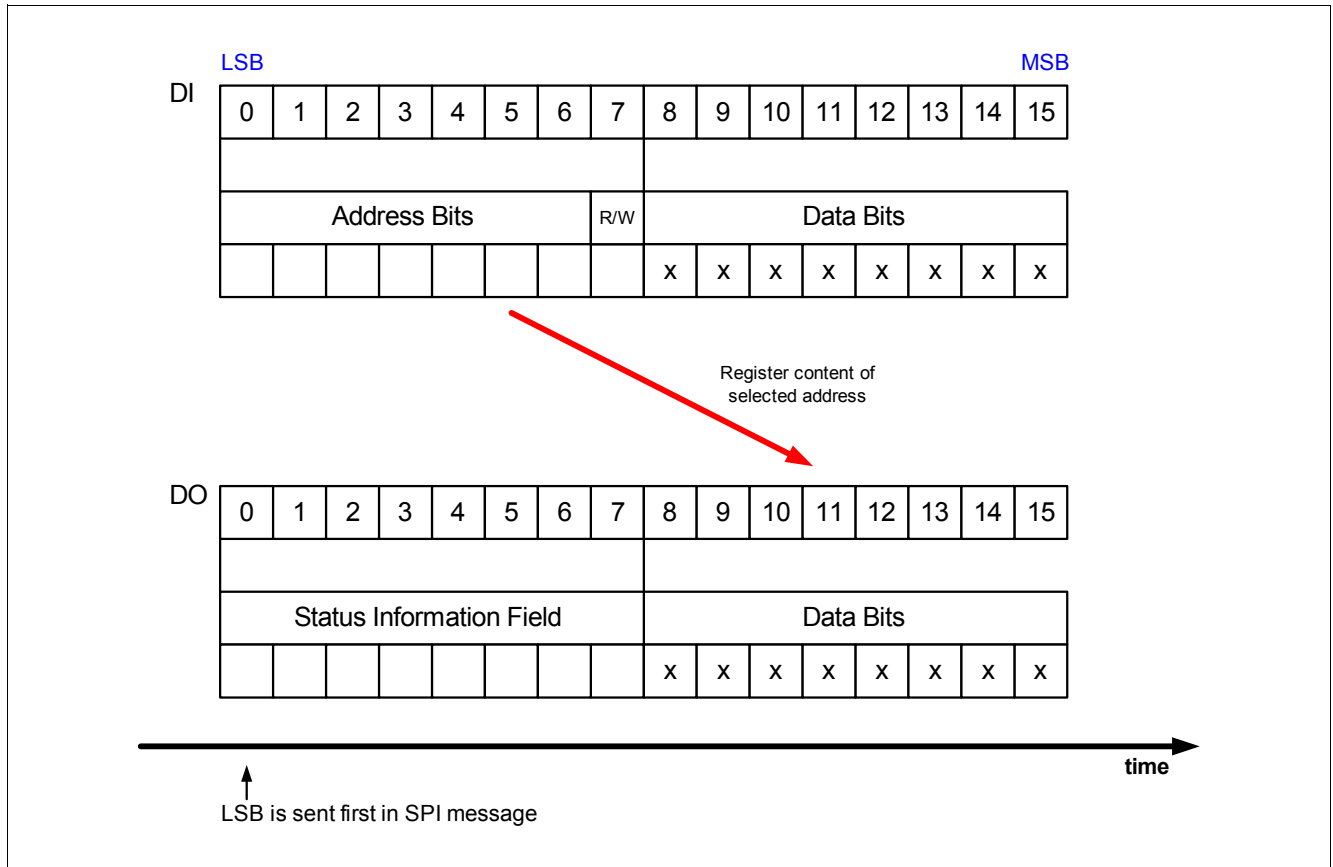

Figure 43 SPI Operation Mode

14.4 SPI Bit Mapping

The following figures show the mapping of the registers and the SPI bits of the respective registers.

The Control Registers '000 0000' to '001 1110' are Read/Write Register. Depending on bit 7 the bits are only read (setting bit 7 to '0') or also written (setting bit 7 to '1'). The new setting of the bit after write can be seen with a new read / write command.

The registers '100 0000' to '111 1110' are Status Registers and can be read or read with clearing the bit (if possible) depending on bit 7. To clear a Data Byte of one of the Status Registers bit 7 must be set to 1. The registers **WK_LVL_STAT**, and **FAM_PROD_STAT** are an exception as they show the actual voltage level at the respective WK pin (LOW/HIGH), or a fixed family/ product ID respectively and can thus not be cleared. It is recommended for proper diagnosis to clear respective status bits for wake events or failure. However, in general it is possible to enable drivers without clearing the respective failure flags.

When changing to a different SBC Mode, certain configurations bits will be cleared automatically or modified:

- The SBC Mode bits are updated to the actual status, e.g. when returning to Normal Mode
- When changing to a low-power mode (Stop/Sleep), the diagnosis bits of the switches and transceivers are not cleared. FOx will stay activated if it was triggered before.
- When changing to SBC Stop Mode, the CAN control bits will not be modified.
- When changing to SBC Sleep Mode, the CAN control bits will be modified if they were not OFF or wake capable before.
- HSx, VCC2 will stay on when going to Sleep-/Stop Mode (configuration can only be done in Normal Mode). Diagnosis is active (OC, OL, OT). In case of a failure the switch is turned off and no wake-up is issued
- The configuration bits for HSx and VCC2 in stand-alone configuration are cleared in SBC Restart Mode. FOx will stay activated if it was triggered before. Depending on the respective configuration, CAN transceivers will be either OFF, woken or still wake capable.

Note: The detailed behavior of the respective SPI bits and control functions is described in [Chapter 14.5](#), [Chapter 14.6](#) and in the respective module chapter. The bit type be marked as 'rwh' in case the SBC will modify respective control bits.

| MSB | | | | | | | | LSB | | | | | | | | | |
|--|---------------|----|----|----|----|---|---|--------------|---|---------------|---|---|---|---|---|--|---|
| 15 | 14 | 13 | 12 | 11 | 10 | 9 | 8 | 7 | 6 | 5 | 4 | 3 | 2 | 1 | 0 | | |
| 8 Data Bits [bits 8... 15] for Configuration & Status Information | | | | | | | | Reg. Type | 7 Address Bits [bits 0...6] for Register Selection | | | | | | | | |
| Control Registers | M_S_CTRL | | | | | | | | rw | 0 0 0 0 0 0 1 | | | | | | | |
| | HW_CTRL | | | | | | | | rw | 0 0 0 0 0 1 0 | | | | | | | |
| | WD_CTRL | | | | | | | | rw | 0 0 0 0 0 1 1 | | | | | | | |
| | BUS_CTRL_1 | | | | | | | | rw | 0 0 0 0 1 0 0 | | | | | | | |
| | BUS_CTRL_2 | | | | | | | | rw | 0 0 0 0 1 0 1 | | | | | | | |
| | WK_CTRL_1 | | | | | | | | rw | 0 0 0 0 1 1 0 | | | | | | | |
| | WK_CTRL_2 | | | | | | | | rw | 0 0 0 0 1 1 1 | | | | | | | |
| | WK_PUPD_CTRL | | | | | | | | rw | 0 0 0 1 0 0 0 | | | | | | | |
| | WK_FLT_CTRL | | | | | | | | rw | 0 0 0 1 0 0 1 | | | | | | | |
| | TIMER1_CTRL | | | | | | | | rw | 0 0 0 1 1 0 0 | | | | | | | |
| | TIMER2_CTRL | | | | | | | | rw | 0 0 0 1 1 0 1 | | | | | | | |
| | SW_SD_CTRL | | | | | | | | rw | 0 0 1 0 0 0 0 | | | | | | | |
| | HS_CTRL_1 | | | | | | | | rw | 0 0 1 0 1 0 0 | | | | | | | |
| | HS_CTRL_2 | | | | | | | | rw | 0 0 1 0 1 0 1 | | | | | | | |
| | GPIO_CTRL | | | | | | | | rw | 0 0 1 0 1 1 1 | | | | | | | |
| | PWM1_CTRL | | | | | | | | rw | 0 0 1 1 0 0 0 | | | | | | | |
| | PWM2_CTRL | | | | | | | | rw | 0 0 1 1 0 0 1 | | | | | | | |
| | PWM_FREQ_CTRL | | | | | | | | rw | 0 0 1 1 1 0 0 | | | | | | | |
| SYS_STAT_CTRL | | | | | | | | rw | 0 0 1 1 1 1 0 | | | | | | | | |
| Status Registers | SUP_STAT_2 | | | | | | | | rc | 1 0 0 0 0 0 0 | | | | | | | 5 |
| | SUP_STAT_1 | | | | | | | | rc | 1 0 0 0 0 0 1 | | | | | | | 0 |
| | THERM_STAT | | | | | | | | rc | 1 0 0 0 0 1 0 | | | | | | | 1 |
| | DEV_STAT | | | | | | | | rc | 1 0 0 0 0 1 1 | | | | | | | 2 |
| | BUS_STAT_1 | | | | | | | | rc | 1 0 0 0 1 0 0 | | | | | | | 3 |
| | WK_STAT_1 | | | | | | | | rc | 1 0 0 0 1 1 0 | | | | | | | 4 |
| | WK_STAT_2 | | | | | | | | rc | 1 0 0 0 1 1 1 | | | | | | | 4 |
| | WK_LVL_STAT | | | | | | | | r | 1 0 0 1 0 0 0 | | | | | | | - |
| | HS_OC_OT_STAT | | | | | | | | rc | 1 0 1 0 1 0 0 | | | | | | | 6 |
| | HS_OL_STAT | | | | | | | | rc | 1 0 1 0 1 0 1 | | | | | | | 7 |
| FAM_PROD_STAT | | | | | | | | r | 1 1 1 1 1 1 0 | | | | | | | | |

Figure 44 SPI Register Mapping

| Register Short Name | Data Bit 15...8 | | | | | | | 7 Access Mode | 6...0 Address Ab...A0 |
|-------------------------------------|-----------------|---------------|-------------|--------------|------------|--------------|--------------|------------------|--------------------------|
| | 15 D7 | 14 D6 | 13 D5 | 12 D4 | 11 D3 | 10 D2 | 9 D1 | | |
| CONTROL REGISTERS | | | | | | | | | |
| M_S_CTRL | MODE 1 | MODE 0 | reserved | VCC2_ON 1 | VCC2_ON 0 | VCC1_OV_RST | VCC1_RT 1 | VCC1_RT 0 | 0000001 |
| HW_CTRL | reserved | SOFT_RESET_RO | FO_ON | reserved | reserved | reserved | reserved | CFG | 0000010 |
| WD_CTRL | CHECKSUM | WD_STM_EN_0 | WD_WIN | WD_EN_WK_BUS | reserved | WD_TIMER 2 | WD_TIMER 1 | WD_TIMER_0 | 0000011 |
| BUS_CTRL_1 | reserved | reserved | reserved | reserved | reserved | reserved | CAN 1 | CAN 0 | 0000100 |
| BUS_CTRL_2 | reserved | reserved | 1_PEAK_TH | reserved | reserved | reserved | reserved | reserved | 0000101 |
| WK_CTRL_1 | TIMER2_WK_EN | TIMER1_WK_EN | reserved | reserved | reserved | WD_STM_EN_1 | reserved | reserved | 0000110 |
| WK_CTRL_2 | INT_GLOBAL | reserved | WK_MEAS | reserved | reserved | WK3_EN | WK2_EN | WK1_EN | 0000111 |
| WK_PUPD_CTRL | reserved | reserved | WK3_PUPD_1 | WK3_PUPD_0 | WK2_PUPD_1 | WK2_PUPD_0 | WK1_PUPD_1 | WK1_PUPD_0 | 0001000 |
| WK_FLT_CTRL | reserved | reserved | WK3_FLT_1 | WK3_FLT_0 | WK2_FLT_1 | WK2_FLT_0 | WK1_FLT_1 | WK1_FLT_0 | 0001001 |
| TIMER1_CTRL | reserved | TIMER1_ON 2 | TIMER1_ON 1 | TIMER1_ON 0 | reserved | TIMER1_PER 2 | TIMER1_PER 1 | TIMER1_PER 0 | 0001100 |
| TIMER2_CTRL | reserved | TIMER2_ON 2 | TIMER2_ON 1 | TIMER2_ON 0 | reserved | TIMER2_PER 2 | TIMER2_PER 1 | TIMER2_PER 0 | 0001101 |
| SW_SD_CTRL | reserved | HS_OV_SD_EN | HS_UV_SD_EN | HS_OV_UV_REC | reserved | reserved | reserved | reserved | 0010000 |
| HS_CTRL_1 | reserved | HS2_2 | HS2_1 | HS2_0 | reserved | HS1_2 | HS1_1 | HS1_0 | 0010100 |
| HS_CTRL_2 | reserved | HS4_2 | HS4_1 | HS4_0 | reserved | HS3_2 | HS3_1 | HS3_0 | 0010101 |
| GPIO_CTRL | FO_DC 1 | FO_DC 0 | GPIO2_2 | GPIO2_1 | GPIO2_0 | GPIO1_2 | GPIO1_1 | GPIO1_0 | 0010111 |
| PWM1_CTRL | PWM1_DC 7 | PWM1_DC 6 | PWM1_DC 5 | PWM1_DC 4 | PWM1_DC 3 | PWM1_DC 2 | PWM1_DC 1 | PWM1_DC 0 | 0011000 |
| PWM2_CTRL | PWM2_DC 7 | PWM2_DC 6 | PWM2_DC 5 | PWM2_DC 4 | PWM2_DC 3 | PWM2_DC 2 | PWM2_DC 1 | PWM2_DC 0 | 0011001 |
| PWM_FREQ_CTRL | reserved | reserved | reserved | reserved | reserved | PWM2_FREQ 0 | reserved | PWM1_FREQ 0 | 0011100 |
| SYS_STAT_CTRL | SYS_STAT 7 | SYS_STAT 6 | SYS_STAT 5 | SYS_STAT 4 | SYS_STAT 3 | SYS_STAT 2 | SYS_STAT 1 | SYS_STAT 0 | 0011110 |
| STATUS REGISTERS | | | | | | | | | |
| SUP_STAT 2 | reserved | VS_UV | reserved | reserved | reserved | reserved | VCC1_OV | VCC1_WARN | 1000000 |
| SUP_STAT 1 | POR | VSHS_UV | VSHS_OV | VCC2_OT | VCC2_UV | VCC1_SC | VCC1_UV_FS | VCC1_UV | 1000001 |
| THERM_STAT | reserved | reserved | reserved | reserved | reserved | TSD2 | TSD1 | TPW | 1000010 |
| DEV_STAT | DEV_STAT 1 | DEV_STAT 0 | reserved | reserved | WD_FAIL 1 | WD_FAIL 0 | SPI_FAIL | FAILURE | 1000011 |
| BUS_STAT_1 | reserved | reserved | reserved | reserved | reserved | CAN_FAIL 1 | CAN_FAIL_0 | VCAN_UV | 1000100 |
| WK_STAT_1 | reserved | reserved | CAN_WU | TIMER_WU | reserved | WK3_WU | WK2_WU | WK1_WU | 1000110 |
| WK_STAT_2 | reserved | reserved | GPIO2_WU | GPIO1_WU | reserved | reserved | reserved | reserved | 1000111 |
| WK_LVL_STAT | SBC_DEV_LVL | CFGP | GPIO2_LVL | GPIO1_LVL | reserved | WK3_LVL | WK2_LVL | WK1_LVL | 1001000 |
| HS_OC_OT_STAT | reserved | reserved | reserved | HS4_OC_OT | HS4_OC_OT | HS3_OC_OT | HS2_OC_OT | HS1_OC_OT | 1010100 |
| HS_OL_STAT | reserved | reserved | reserved | HS4_OL | HS4_OL | HS3_OL | HS2_OL | HS1_OL | 1010101 |
| FAMILY AND PRODUCT REGISTERS | | | | | | | | | |
| FAM_PROD_STAT | FAM_3 | FAM_2 | FAM_1 | FAM_0 | PROD_3 | PROD_2 | PROD_1 | PROD_0 | 1111110 |

Figure 45 TLE9260QX SPI Bit Mapping

14.5 SPI Control Registers

READ/WRITE Operation (see also [Chapter 14.3](#)):

- The 'POR / Soft Reset Value' defines the register content after POR or SBC Reset.
- The 'Restart Value' defines the register content after SBC Restart, where 'x' means the bit is unchanged.
- One 16-bit SPI command consist of two bytes:
 - the 7-bit address and one additional bit for the register access mode and
 - following the data byteThe numbering of following bit definitions refers to the data byte and correspond to the bits D0...D7 and to the SPI bits 8...15 (see also figure before).
- There are three different bit types:
 - 'r' = READ: read only bits (or reserved bits)
 - 'rw' = READ/WRITE: readable and writable bits
 - 'rwh' = READ/WRITE/Hardware: readable/writable bits, which can also be modified by the SBC hardware
- Reserved bits are marked as "Reserved" and always read as "0". The respective bits shall also be programmed as "0".
- Reading a register is done byte wise by setting the SPI bit 7 to "0" (= Read Only).
- Writing to a register is done byte wise by setting the SPI bit 7 to "1".
- SPI control bits are in general not cleared or changed automatically. This must be done by the microcontroller via SPI programming. Exceptions to this behavior are stated at the respective register description and the respective bit type is marked with a 'h' meaning that the SBC is able to change the register content.

The registers are addressed wordwise.

14.5.1 General Control Registers

M_S_CTRL

Mode- and Supply Control (Address 000 0001_B)

POR / Soft Reset Value: 0000 0000_B; Restart Value: 0000 00xx_B

| | | | | | | | |
|--------|--------|----------|-----------|-----------|-----------------|-----------|-----------|
| 7 | 6 | 5 | 4 | 3 | 2 | 1 | 0 |
| MODE_1 | MODE_0 | Reserved | VCC2_ON_1 | VCC2_ON_0 | VCC1_OV_RS T | VCC1_RT_1 | VCC1_RT_0 |
| rwh | rwh | rwh | rwh | rwh | rwh | rw | rw |

| Field | Bits | Type | Description |
|--------------------|------|------|---|
| MODE | 7:6 | rwh | SBC Mode Control 00 _B , SBC Normal Mode 01 _B , SBC Sleep Mode 10 _B , SBC Stop Mode 11 _B , SBC Reset: Soft Reset is executed (configuration of RO triggering in bit SOFT_RESET_RO) |
| Reserved | 5 | r | Reserved, always reads as 0 |
| VCC2_ON | 4:3 | rwh | VCC2 Mode Control 00 _B , VCC2 off 01 _B , VCC2 on in Normal Mode 10 _B , VCC2 on in Normal and Stop Mode 11 _B , VCC2 always on (except in SBC Fail-Safe Mode) |
| VCC1_OV_RST | 2 | rwh | VCC1 Over Voltage leading to Restart / Fail-Safe Mode enable 0 _B , VCC1_OV is set in case of VCC1_OV; no SBC Restart or Fail-Safe is entered for VCC1_OV 1 _B , VCC1_OV is set in case of VCC1_OV; depending on the device configuration SBC Restart or SBC Fail-Safe Mode is entered (see Chapter 5.1.1); |
| VCC1_RT | 1:0 | rw | VCC1 Reset Threshold Control 00 _B , Vrt1 selected (highest threshold) 01 _B , Vrt2 selected 10 _B , Vrt3 selected 11 _B , Vrt4 selected |

Notes

1. It is not possible to change from Stop to Sleep Mode via SPI Command. See also the State Machine Chapter
2. After entering SBC Restart Mode, the MODE bits will be automatically set to SBC Normal Mode. The VCC2_ON bits will be automatically set to OFF after entering SBC Restart Mode and after OT.
3. The SPI output will always show the previously written state with a Write Command (what has been programmed before)

HW_CTRL

Mode- and Supply Control (Address 000 0010_B)

POR / Soft Reset Value: 0000 0000_B; Restart Value: 0x00 000x_B

| | | | | | | | |
|----------|-------------------|-------|----------|----------|----------|----------|-----|
| 7 | 6 | 5 | 4 | 3 | 2 | 1 | 0 |
| Reserved | SOFT_RESET _RO | FO_ON | Reserved | Reserved | Reserved | Reserved | CFG |
| r | rw | rwh | r | r | r | r | rw |

| Field | Bits | Type | Description |
|---------------|------|------|---|
| Reserved | 7 | r | Reserved, always reads as 0 |
| SOFT_RESET_RO | 6 | rw | Soft Reset Configuration 0 _B , RO will be triggered (pulled low) during a Soft Reset 1 _B , No RO triggering during a Soft Reset |
| FO_ON | 5 | rwh | Failure Output Activation (FO1..3) 0 _B , FOx not activated by software, FO can be activated by defined failures (see Chapter 12) 1 _B , FOx activated by software (via SPI) |
| Reserved | 4 | r | Reserved, always reads as 0 |
| Reserved | 3 | r | Reserved, always reads as 0 |
| Reserved | 2 | r | Reserved, always reads as 0 |
| Reserved | 1 | r | Reserved, always reads as 0 |
| CFG | 0 | rw | Configuration Select (see also Table 5) 0 _B , Depending on hardware configuration, SBC Restart or Fail-Safe Mode is reached after the 2. watchdog trigger failure (=default) - Config 3/4 1 _B , Depending on hardware configuration, SBC Restart or Fail-Safe Mode is reached after the 1. watchdog trigger failure - Config 1/2 |

Notes

1. Clearing the FO_ON bit will not disable the FOx outputs for the case a failure occurred which triggered the FOx outputs. In this case the FOx outputs have to be disabled by clearing the FAILURE bit.
If the FO_ON bit is set by the software then it will be cleared by the SBC after SBC Restart Mode was entered and the FOx outputs will be disabled. See also [Chapter 12](#) for FOx activation and deactivation.

WD_CTRL

Watchdog Control (Address 000 0011_B)

POR / Soft Reset Value: 0001 0100_B; Restart Value: x0xx 0100_B

| | | | | | | | |
|----------|-------------|--------|--------------|----------|------------|------------|------------|
| 7 | 6 | 5 | 4 | 3 | 2 | 1 | 0 |
| CHECKSUM | WD_STM_EN_0 | WD_WIN | WD_EN_WK_BUS | Reserved | WD_TIMER_2 | WD_TIMER_1 | WD_TIMER_0 |
| rw | rwh | rw | rw | r | rwh | rwh | rwh |

| Field | Bits | Type | Description |
|--------------|------|------|---|
| CHECKSUM | 7 | rw | Watchdog Setting Check Sum Bit The sum of bits 7:0 needs to have even parity (see Chapter 13.2.3) 0 _B , Counts as 0 for checksum calculation 1 _B , Counts as 1 for checksum calculation |
| WD_STM_EN_0 | 6 | rwh | Watchdog Deactivation during Stop Mode, bit 0 (Chapter 13.2.4) 0 _B , Watchdog is active in Stop Mode 1 _B , Watchdog is deactivated in Stop Mode |
| WD_WIN | 5 | rw | Watchdog Type Selection 0 _B , Watchdog works as a Time-Out watchdog 1 _B , Watchdog works as a Window watchdog |
| WD_EN_WK_BUS | 4 | rwh | Watchdog Enable after Bus (CAN) Wake in SBC Stop Mode 0 _B , Watchdog will not start after a CAN wake 1 _B , Watchdog starts with a long open window after CAN Wake |
| Reserved | 3 | r | Reserved, always reads as 0 |
| WD_TIMER | 2:0 | rwh | Watchdog Timer Period 000 _B , 10ms 001 _B , 20ms 010 _B , 50ms 011 _B , 100ms 100 _B , 200ms 101 _B , 500ms 110 _B , 1000ms 111 _B , reserved |

Notes

1. See also [Chapter 13.2.4](#) for more information on disabling the watchdog in SBC Stop Mode.
2. See [Chapter 13.2.5](#) for more information on the effect of the bit WD_EN_WK_BUS.
3. See [Chapter 13.2.3](#) for calculation of checksum.

BUS_CTRL_1

Bus Control (Address 000 0100_B)

POR / Soft Reset Value: 0000 0000_B; Restart Value: 0000 00yy_B

| | | | | | | | |
|----------|----------|----------|----------|----------|----------|-------|-------|
| 7 | 6 | 5 | 4 | 3 | 2 | 1 | 0 |
| Reserved | Reserved | Reserved | Reserved | Reserved | Reserved | CAN_1 | CAN_0 |
| r | r | r | r | r | r | rwh | rwh |

| Field | Bits | Type | Description |
|----------|------|------|--|
| Reserved | 7:3 | r | Reserved, always reads as 0 |
| Reserved | 2 | r | Reserved, always reads as 0 |
| CAN | 1:0 | rwh | HS-CAN Module Modes 00 _B , CAN OFF 01 _B , CAN is wake capable 10 _B , CAN Receive Only Mode 11 _B , CAN Normal Mode |

Notes

1. The reset values for the CAN transceivers are marked with 'y' because they will vary depending on the cause of change - see below.
2. see [Figure 19](#) for detailed state changes of CAN Transceiver for different SBC modes.
3. Failure Handling Mechanism: When the device enters Fail-Safe Mode due to a failure (TSD2, WD-Failure,...), then the wake registers [BUS_CTRL_1](#), and [WK_CTRL_2](#) are reset to following values (=wake sources) 'xxx0 1001', '0000 0001' and 'x0xx 0111' in order to ensure that the device can be woken again.

BUS_CTRL_2

Bus Control (Address 000 0101_B)

POR / Soft Reset Value: 0000 0000_B; Restart Value: 00x0 0000_B

| | | | | | | | |
|----------|----------|-----------|----------|----------|----------|----------|----------|
| 7 | 6 | 5 | 4 | 3 | 2 | 1 | 0 |
| Reserved | Reserved | I_PEAK_TH | Reserved | Reserved | Reserved | Reserved | Reserved |
| r | r | rw | r | r | r | r | r |

| Field | Bits | Type | Description |
|-----------|------|------|--|
| Reserved | 7:6 | r | Reserved, always reads as 0 |
| I_PEAK_TH | 5 | rw | VCC1 Active Peak Threshold Selection 0 _B , low VCC1 active peak threshold selected (ICC1,peak_1) 1 _B , higher VCC1 active peak threshold selected (ICC1,peak_2) |
| Reserved | 4:0 | r | Reserved, always reads as 0 |

Notes

1. The bit **I_PEAK_TH** can be modified in SBC Init and Normal Mode. In SBC Stop Mode this bit is Read only but SPI_FAIL will not be set when trying to modify the bit in SBC STOP Mode and no INT is triggered in case **INT_GLOBAL** is set.
2. see **Figure 19** for detailed state changes of CAN Transceiver for different SBC modes
3. Failure Handling Mechanism: When the device enters Fail-Safe Mode due to a failure (TSD2, WD-Failure,...), then the wake registers **BUS_CTRL_1**, **BUS_CTRL_2** and **WK_CTRL_2** are reset to following values (=wake sources) 'xxx0 1001', '0000 0001' and 'x0xx 0111' in order to ensure that the device can be woken again.

WK_CTRL_1

Internal Wake Input Control (Address 000 0110_B)

POR / Soft Reset Value: 0000 0000_B; Restart Value: xx00 0000_B

| | | | | | | | |
|--------------|--------------|----------|----------|----------|-------------|----------|----------|
| 7 | 6 | 5 | 4 | 3 | 2 | 1 | 0 |
| TIMER2_WK_EN | TIMER1_WK_EN | Reserved | Reserved | Reserved | WD_STM_EN_1 | Reserved | Reserved |
| rw | rw | r | r | r | rwh | r | r |

| Field | Bits | Type | Description |
|--------------|------|------|--|
| TIMER2_WK_EN | 7 | rw | Timer2 Wake Source Control (for cyclic wake) 0 _B , Timer2 wake disabled 1 _B , Timer2 is enabled as a wake source |
| TIMER1_WK_EN | 6 | rw | Timer1 Wake Source Control (for cyclic wake) 0 _B , Timer1 wake disabled 1 _B , Timer1 is enabled as a wake source |
| Reserved | 5:3 | r | Reserved, always reads as 0 |
| WD_STM_EN_1 | 2 | rwh | Watchdog Deactivation during Stop Mode, bit 1 (Chapter 13.2.4) 0 _B , Watchdog is active in Stop Mode 1 _B , Watchdog is deactivated in Stop Mode |
| Reserved | 1:0 | r | Reserved, always reads as 0 |

WK_CTRL_2

External Wake Source Control (Address 000 0111_B)

POR / Soft Reset Value: 0000 0111_B; Restart Value: x0x0 0xxx_B

| | | | | | | | |
|------------|----------|---------|----------|----------|--------|--------|--------|
| 7 | 6 | 5 | 4 | 3 | 2 | 1 | 0 |
| INT_GLOBAL | Reserved | WK_MEAS | Reserved | Reserved | WK3_EN | WK2_EN | WK1_EN |
| rw | r | rw | r | r | rw | rw | rw |

| Field | Bits | Type | Description |
|------------|------|------|---|
| INT_GLOBAL | 7 | rw | Global Interrupt Configuration (see also Chapter 11.1) 0 _B , Only wake sources trigger INT (default) 1 _B , All status information register bits will trigger INT (including all wake sources) |
| Reserved | 6 | r | Reserved, always reads as 0 |
| WK_MEAS | 5 | rw | WK / Measurement selection (see also Chapter 10.2.2) 0 _B , WK functionality enabled for WK1 and WK2 1 _B , Measurement functionality enabled; WK1 & WK2 are disabled as wake sources, i.e. bits WK1/2_EN bits are ignored |
| Reserved | 4:3 | r | Reserved, always reads as 0 |
| WK3_EN | 2 | rw | WK3 Wake Source Control 0 _B , WK3 wake disabled 1 _B , WK3 is enabled as a wake source |
| WK2_EN | 1 | rw | WK2 Wake Source Control 0 _B , WK2 wake disabled 1 _B , WK2 is enabled as a wake source |
| WK1_EN | 0 | rw | WK1 Wake Source Control 0 _B , WK1 wake disabled 1 _B , WK1 is enabled as a wake source |

Notes

1. WK_MEAS is by default configured for standard WK functionality (WK1 and WK2). The bits WK1_EN and WK2_EN are ignored in case WK_MEAS is activated. If the bit is set to '1' then the measurement function is enabled during Normal Mode & the bits WK1_EN and WK2_EN are ignored. The bits WK1"/_LVL bits need to be ignored as well.
2. The wake sources CAN are selected in the register [BUS_CTRL_1](#) by setting the respective bits to 'wake capable'
3. Failure Handling Mechanism: When the device enters Fail-Safe Mode due to a failure (TSD2, WD-Failure,...), then the wake registers [BUS_CTRL_1](#) and [WK_CTRL_2](#) are reset to following values (=wake sources) 'xxx0 1001', '0000 0001' and 'x0xx 0111' in order to ensure that the device can be woken again.

WK_PUPD_CTRL

Wake Input Level Control (Address 000 1000_B)

POR / Soft Reset Value: 0000 0000_B; Restart Value: 00xx xxxx_B

| | | | | | | | |
|----------|----------|------------|------------|------------|------------|------------|------------|
| 7 | 6 | 5 | 4 | 3 | 2 | 1 | 0 |
| Reserved | Reserved | WK3_PUPD_1 | WK3_PUPD_0 | WK2_PUPD_1 | WK2_PUPD_0 | WK1_PUPD_1 | WK1_PUPD_0 |
| r | r | rw | rw | rw | rw | rw | rw |

| Field | Bits | Type | Description |
|----------|------|------|--|
| Reserved | 7:6 | r | Reserved, always reads as 0 |
| WK3_PUPD | 5:4 | rw | WK3 Pull-Up / Pull-Down Configuration 00 _B , No pull-up / pull-down selected 01 _B , Pull-down resistor selected 10 _B , Pull-up resistor selected 11 _B , Automatic switching to pull-up or pull-down |
| WK2_PUPD | 3:2 | rw | WK2 Pull-Up / Pull-Down Configuration 00 _B , No pull-up / pull-down selected 01 _B , Pull-down resistor selected 10 _B , Pull-up resistor selected 11 _B , Automatic switching to pull-up or pull-down |
| WK1_PUPD | 1:0 | rw | WK1 Pull-Up / Pull-Down Configuration 00 _B , No pull-up / pull-down selected 01 _B , Pull-down resistor selected 10 _B , Pull-up resistor selected 11 _B , Automatic switching to pull-up or pull-down |

WK_FLT_CTRL

Wake Input Filter Time Control (Address 000 1001_B)

POR / Soft Reset Value: 0000 0000_B; Restart Value: 00xx xxxx_B

| | | | | | | | |
|----------|----------|-----------|-----------|-----------|-----------|-----------|-----------|
| 7 | 6 | 5 | 4 | 3 | 2 | 1 | 0 |
| Reserved | Reserved | WK3_FLT_1 | WK3_FLT_0 | WK2_FLT_1 | WK2_FLT_0 | WK1_FLT_1 | WK1_FLT_0 |
| r | r | rw | rw | rw | rw | rw | rw |

| Field | Bits | Type | Description |
|----------|------|------|--|
| Reserved | 7:6 | r | Reserved, always reads as 0 |
| WK3_FLT | 5:4 | rw | WK3 Filter Time Configuration 00 _B , Configuration A: Filter with 16μs filter time (static sensing) 01 _B , Configuration B: Filter with 64μs filter time (static sensing) 10 _B , Configuration C: Filtering at the end of the on-time; a filter time of 16μs (cyclic sensing) is selected, Timer1 11 _B , Configuration D: Filtering at the end of the on-time; a filter time of 16μs (cyclic sensing) is selected, Timer2 |
| WK2_FLT | 3:2 | rw | WK2 Filter Time Configuration 00 _B , Configuration A: Filter with 16μs filter time (static sensing) 01 _B , Configuration B: Filter with 64μs filter time (static sensing) 10 _B , Configuration C: Filtering at the end of the on-time; a filter time of 16μs (cyclic sensing) is selected, Timer1 11 _B , Configuration D: Filtering at the end of the on-time; a filter time of 16μs (cyclic sensing) is selected, Timer2 |
| WK1_FLT | 1:0 | rw | WK1 Filter Time Configuration 00 _B , Configuration A: Filter with 16μs filter time (static sensing) 01 _B , Configuration B: Filter with 64μs filter time (static sensing) 10 _B , Configuration C: Filtering at the end of the on-time; a filter time of 16μs (cyclic sensing) is selected, Timer1 11 _B , Configuration D: Filtering at the end of the on-time; a filter time of 16μs (cyclic sensing) is selected, Timer2 |

Note: When selecting a filter time configuration, the user must make sure to also assign the respective timer to at least one HS switch during cyclic sense operation

TIMER1_CTRL

Timer1 Control and Selection (Address 000 1100_B)

POR / Soft Reset Value: 0000 0000_B; Restart Value: 0000 0000_B

| | | | | | | | |
|----------|-----------------|-----------------|-----------------|----------|------------------|------------------|------------------|
| 7 | 6 | 5 | 4 | 3 | 2 | 1 | 0 |
| Reserved | TIMER1_ ON_2 | TIMER1_ ON_1 | TIMER1_ ON_0 | Reserved | TIMER1_ PER_2 | TIMER1_ PER_1 | TIMER1_ PER_0 |
| r | rwh | rwh | rwh | r | rwh | rwh | rwh |

| Field | Bits | Type | Description |
|----------------|------|------|--|
| Reserved | 7 | r | Reserved, always reads as 0 |
| TIMER1_ ON | 6:4 | rwh | Timer1 On-Time Configuration 000 _B , OFF / Low (timer not running, HSx output is low) 001 _B , 0.1ms on-time 010 _B , 0.3ms on-time 011 _B , 1.0ms on-time 100 _B , 10ms on-time 101 _B , 20ms on-time 110 _B , OFF / HIGH (timer not running, HSx output is high) 111 _B , reserved |
| Reserved | 3 | r | Reserved, always reads as 0 |
| TIMER1_ PER | 2:0 | rwh | Timer1 Period Configuration 000 _B , 10ms 001 _B , 20ms 010 _B , 50ms 011 _B , 100ms 100 _B , 200ms 101 _B , 1s 110 _B , 2s 111 _B , reserved |

Notes

1. A timer must be first assigned and is then automatically activated as soon as the on-time is configured.
2. If cyclic sense is selected and the HS switches are cleared during SBC Restart Mode, then also the timer settings (period and on-time) are cleared to avoid incorrect switch detection.
3. in case the timer are set as wake sources and cyclic sense is running, then both cyclic sense and cyclic wake will be active at the same time.

TIMER2_CTRL

Timer2 Control and selection (Address 000 1101_B)

POR / Soft Reset Value: 0000 0000_B; Restart Value: 0000 0000_B

| | | | | | | | |
|----------|-------------|-------------|-------------|----------|--------------|--------------|--------------|
| 7 | 6 | 5 | 4 | 3 | 2 | 1 | 0 |
| Reserved | TIMER2_ON_2 | TIMER2_ON_1 | TIMER2_ON_0 | Reserved | TIMER2_PER_2 | TIMER2_PER_1 | TIMER2_PER_0 |
| r | rwh | rwh | rwh | r | rwh | rwh | rwh |

| Field | Bits | Type | Description |
|------------|------|------|--|
| Reserved | 7 | r | Reserved, always reads as 0 |
| TIMER2_ON | 6:4 | rwh | Timer2 On-Time Configuration 000 _B , OFF / Low (timer not running, HSx output is low) 001 _B , 0.1ms on-time 010 _B , 0.3ms on-time 011 _B , 1.0ms on-time 100 _B , 10ms on-time 101 _B , 20ms on-time 110 _B , OFF / HIGH (timer not running, HSx output is high) 111 _B , reserved |
| Reserved | 3 | r | Reserved, always reads as 0 |
| TIMER2_PER | 2:0 | rwh | Timer2 Period Configuration 000 _B , 10ms 001 _B , 20ms 010 _B , 50ms 011 _B , 100ms 100 _B , 200ms 101 _B , 1s 110 _B , 2s 111 _B , reserved |

Notes

1. A timer must be first assigned and is then automatically activated as soon as the on-time is configured.
2. If cyclic sense is selected and the HS switches are cleared during SBC Restart Mode, then also the timer settings (period and on-time) are cleared to avoid incorrect switch detection.

SW_SD_CTRL

Switch Shutdown Control (Address 001 0000_B)

POR / Soft Reset Value: 0000 0000_B; Restart Value: 0xxx 0000_B

| | | | | | | | |
|----------|-------------|-------------|--------------|----------|----------|----------|----------|
| 7 | 6 | 5 | 4 | 3 | 2 | 1 | 0 |
| Reserved | HS_OV_SD_EN | HS_UV_SD_EN | HS_OV_UV_REC | Reserved | Reserved | Reserved | Reserved |
| r | rw | rw | rw | r | r | r | r |

| Field | Bits | Type | Description |
|--------------|------|------|---|
| Reserved | 7 | r | Reserved, always reads as 0 |
| HS_OV_SD_EN | 6 | rw | Shutdown Disabling of HS1...4 in case of VSHS OV 0 _B , shutdown enabled in case of VSHS OV 1 _B , shutdown disabled in case of VSHS OV |
| HS_UV_SD_EN | 5 | rw | Shutdown Disabling of HS1...4 in case of VSHS UV 0 _B , shutdown enabled in case of VSHS UV 1 _B , shutdown disabled in case of VSHS UV |
| HS_OV_UV_REC | 4 | rw | Switch Recovery after Removal of VSHS OV/UV for HS1...4 0 _B , Switch recovery is disabled 1 _B , Previous state before VSHS OV/UV is enabled after OV/UV condition is removed |
| Reserved | 3:0 | r | Reserved, always reads as 0 |

HS_CTRL1

High-Side Switch Control 1 (Address 001 0100_B)

POR / Soft Reset Value: 0000 0000_B; Restart Value: 0000 0000_B

| | | | | | | | |
|----------|-------|-------|-------|----------|-------|-------|-------|
| 7 | 6 | 5 | 4 | 3 | 2 | 1 | 0 |
| Reserved | HS2_2 | HS2_1 | HS2_0 | Reserved | HS1_2 | HS1_1 | HS1_0 |
| rw | rwh | rwh | rwh | r | rwh | rwh | rwh |

| Field | Bits | Type | Description |
|----------|------|------|---|
| Reserved | 7 | r | Reserved, always reads as 0 |
| HS2 | 6:4 | rwh | HS2 Configuration 000 _B , Off 001 _B , On 010 _B , Controlled by Timer1 011 _B , Controlled by Timer2 100 _B , Controlled by PWM1 101 _B , Controlled by PWM2 110 _B , Reserved 111 _B , Reserved |
| Reserved | 3 | r | Reserved, always reads as 0 |
| HS1 | 2:0 | rwh | HS1 Configuration 000 _B , Off 001 _B , On 010 _B , Controlled by Timer1 011 _B , Controlled by Timer2 100 _B , Controlled by PWM1 101 _B , Controlled by PWM2 110 _B , Reserved 111 _B , Reserved |

Note: The bits for the switches are also reset in case of overcurrent and overtemperature.

HS_CTRL2

High-Side Switch Control 2 (Address 001 0101_B)

POR / Soft Reset Value: 0000 0000_B; Restart Value: 0000 0000_B

| | | | | | | | |
|----------|-------|-------|-------|----------|-------|-------|-------|
| 7 | 6 | 5 | 4 | 3 | 2 | 1 | 0 |
| Reserved | HS4_2 | HS4_1 | HS4_0 | Reserved | HS3_2 | HS3_1 | HS3_0 |
| r | rwh | rwh | rwh | r | rwh | rwh | rwh |

| Field | Bits | Type | Description |
|----------|------|------|---|
| Reserved | 7 | r | Reserved, always reads as 0 |
| HS4 | 6:4 | rwh | HS4 Configuration 000 _B , Off 001 _B , On 010 _B , Controlled by Timer1 011 _B , Controlled by Timer2 100 _B , Controlled by PWM1 101 _B , Controlled by PWM2 110 _B , Reserved 111 _B , Reserved |
| Reserved | 3 | r | Reserved, always reads as 0 |
| HS3 | 2:0 | rwh | HS3 Configuration 000 _B , Off 001 _B , On 010 _B , Controlled by Timer1 011 _B , Controlled by Timer2 100 _B , Controlled by PWM1 101 _B , Controlled by PWM2 110 _B , Reserved 111 _B , Reserved |

Note: The bits for the switches are also reset in case of overcurrent and overtemperature.

GPIO_CTRL

GPIO Configuration Control (Address 001 0111_B)

POR / Soft Reset Value: 0000 0000_B; Restart Value: xxxx xxxx_B

| | | | | | | | |
|---------|---------|---------|---------|---------|---------|---------|---------|
| 7 | 6 | 5 | 4 | 3 | 2 | 1 | 0 |
| FO_DC_1 | FO_DC_0 | GPIO2_2 | GPIO2_1 | GPIO2_0 | GPIO1_2 | GPIO1_1 | GPIO1_0 |
| rw | rw | rw | rw | rw | rw | rw | rw |

| Field | Bits | Type | Description |
|--------------|------|------|---|
| FO_DC | 7:6 | rw | Duty Cycle Configuration of FO3 (if selected) 00 _B , 20% 01 _B , 10% 10 _B , 5% 11 _B , 2.5% |
| GPIO2 | 5:3 | rw | GPIO2 Configuration 000 _B , FO3 selected 001 _B , FO3 selected 010 _B , FO3 selected 011 _B , FO3 selected 100 _B , OFF 101 _B , Wake input enabled (16µs static filter) 110 _B , Low-Side Switch ON 111 _B , High-Side Switch ON |
| GPIO1 | 2:0 | rw | GPIO1 Configuration 000 _B , FO2 selected 001 _B , FO2 selected 010 _B , FO2 selected 011 _B , FO2 selected 100 _B , OFF 101 _B , Wake input enabled (16µs static filter) 110 _B , Low-Side Switch ON 111 _B , High-Side Switch ON |

Note: When selecting a filter time configuration, the user must make sure to also assign the respective timer to at least one HS switch during cyclic sense operation

PWM1_CTRL

PWM1 Configuration Control (Address 001 1000_B)

POR / Soft Reset Value: 0000 0000_B; Restart Value: xxxx xxxx_B

| | | | | | | | |
|-----------|-----------|-----------|-----------|-----------|-----------|-----------|-----------|
| 7 | 6 | 5 | 4 | 3 | 2 | 1 | 0 |
| PWM1_DC_7 | PWM1_DC_6 | PWM1_DC_5 | PWM1_DC_4 | PWM1_DC_3 | PWM1_DC_2 | PWM1_DC_1 | PWM1_DC_0 |
| rw | rw | rw | rw | rw | rw | rw | rw |

| Field | Bits | Type | Description |
|---------|------|------|---|
| PWM1_DC | 7:0 | rw | PWM1 Duty Cycle (bit0=LSB; bit7=MSB) 0000 0000 _B , 100% OFF xxxx xxxx _B , ON with DC fraction of 255 1111 1111 _B , 100% ON |

Note: The min. On-time during PWM is limited by the actual Ton and Toff time of the respective HS switch, e.g. the PWM setting '000 0001' could not be realized.

PWM2_CTRL

PWM2 Configuration Control (Address 001 1001_B)

POR / Soft Reset Value: 0000 0000_B; Restart Value: xxxx xxxx_B

| | | | | | | | |
|-----------|-----------|-----------|-----------|-----------|-----------|-----------|-----------|
| 7 | 6 | 5 | 4 | 3 | 2 | 1 | 0 |
| PWM2_DC_7 | PWM2_DC_6 | PWM2_DC_5 | PWM2_DC_4 | PWM2_DC_3 | PWM2_DC_2 | PWM2_DC_1 | PWM2_DC_0 |
| rw | rw | rw | rw | rw | rw | rw | rw |

| Field | Bits | Type | Description |
|---------|------|------|---|
| PWM2_DC | 7:0 | rw | PWM2 Duty Cycle (bit0=LSB; bit7=MSB) 0000 0000 _B , 100% OFF xxxx xxxx _B , ON with DC fraction of 255 1111 1111 _B , 100% ON |

Note: The min. On-time during PWM is limited by the actual Ton and Toff time of the respective HS switch, e.g. the PWM setting '000 0001' could not be realized.

PWM_FREQ_CTRL

PWM Frequency Configuration Control (Address 001 1100_B)

POR / Soft Reset Value: 0000 0000_B; Restart Value: 0000 0x0x_B

| | | | | | | | |
|----------|----------|----------|----------|----------|-----------|----------|-----------|
| 7 | 6 | 5 | 4 | 3 | 2 | 1 | 0 |
| Reserved | Reserved | Reserved | Reserved | Reserved | PWM2_FREQ | Reserved | PWM1_FREQ |
| r | r | r | r | r | rw | r | rw |

| Field | Bits | Type | Description |
|-----------|------|------|---|
| Reserved | 7:3 | r | Reserved, always reads as 0 |
| PWM2_FREQ | 2 | rw | PWM2 Frequency Selection 0 _B , 200Hz configuration 1 _B , 400Hz configuration |
| Reserved | 1 | r | Reserved, always reads as 0 |
| PWM1_FREQ | 0 | rw | PWM1 Frequency Selection 0 _B , 200Hz configuration 1 _B , 400Hz configuration |

Note: The min. On-time during PWM is limited by the actual Ton and Toff time of the respective HS switch, e.g. the PWM setting '000 0001' could not be realized.

SYS_STATUS_CTRL

System Status Control (Address 001 1110_B)

POR Value: 0000 0000_B; Restart Value/Soft Reset Value: xxxx xxxx_B

| | | | | | | | |
|------------|------------|------------|------------|------------|------------|------------|------------|
| 7 | 6 | 5 | 4 | 3 | 2 | 1 | 0 |
| SYS_STAT_7 | SYS_STAT_6 | SYS_STAT_5 | SYS_STAT_4 | SYS_STAT_3 | SYS_STAT_2 | SYS_STAT_1 | SYS_STAT_0 |
| rw | rw | rw | rw | rw | rw | rw | rw |

| Field | Bits | Type | Description |
|----------|------|------|--|
| SYS_STAT | 7:0 | rw | System Status Control Byte (bit0=LSB; bit7=MSB) Dedicated byte for system configuration, access only by microcontroller. Cleared after power up and Soft Reset |

Notes

1. The **SYS_STATUS_CTRL** register is an exception for the default values, i.e. it will keep its configured value also after a Soft Reset.
2. This byte is intended for storing system configurations of the ECU by the microcontroller and is only accessible in SBC Normal Mode. The byte is not accessible by the SBC and is also not cleared after Fail-Safe or SBC Restart Mode. It allows the microcontroller to quickly store system configuration without losing the data.

14.6 SPI Status Information Registers

READ/CLEAR Operation (see also [Chapter 14.3](#)):

- One 16-bit SPI command consist of two bytes:
 - the 7-bit address and one additional bit for the register access mode and
 - following the data byteThe numbering of following bit definitions refers to the data byte and correspond to the bits D0...D7 and to the SPI bits 8...15 (see also figure).
- There are two different bit types:
 - 'r' = READ: read only bits (or reserved bits)
 - 'rc' = READ/CLEAR: readable and clearable bits
- Reading a register is done byte wise by setting the SPI bit 7 to "0" (= Read Only)
- Clearing a register is done byte wise by setting the SPI bit 7 to "1"
- SPI status registers are in general not cleared or changed automatically (an exception are the [WD_FAIL](#) bits). This must be done by the microcontroller via SPI command

The registers are addressed wordwise.

14.6.1 General Status Registers

SUP_STAT_2

Supply Voltage Fail Status (Address 100 0000_B)

POR / Soft Reset Value: 0000 0000_B; Restart Value: 0x00 00xx_B

| | | | | | | | |
|----------|-------|----------|----------|----------|----------|---------|-----------|
| 7 | 6 | 5 | 4 | 3 | 2 | 1 | 0 |
| Reserved | VS_UV | Reserved | Reserved | Reserved | Reserved | VCC1_OV | VCC1_WARN |
| r | rc | r | r | r | r | rc | rc |

| Field | Bits | Type | Description |
|-----------|------|------|---|
| Reserved | 7 | r | Reserved, always reads as 0 |
| VS_UV | 6 | rc | VS Under-Voltage Detection ($V_{S,UV}$) 0_B , No VS under voltage detected 1_B , VS under voltage detected |
| Reserved | 5 | r | Reserved, always reads as 0 |
| Reserved | 4:2 | r | Reserved, always reads as 0 |
| VCC1_OV | 1 | rc | VCC1 Over Voltage Detection ($V_{CC1,OV,r}$) 0_B , No VCC1 over voltage warning 1_B , VCC1 over voltage detected |
| VCC1_WARN | 0 | rc | VCC1 Undervoltage Prewarning ($V_{PW,f}$) 0_B , No VCC1 undervoltage prewarning 1_B , VCC1 undervoltage prewarning detected |

Notes

1. The VCC1 undervoltage prewarning threshold $V_{PW,f} / V_{PW,r}$ is a fixed threshold and independent of the VCC1 undervoltage reset thresholds.

SUP_STAT_1

Supply Voltage Fail Status (Address 100 0001_B)

POR / Soft Reset Value: y000 0000_B; Restart Value: xxxx xx0x_B

| | | | | | | | |
|------------|----------------|----------------|----------------|----------------|----------------|-------------------|----------------|
| 7 | 6 | 5 | 4 | 3 | 2 | 1 | 0 |
| POR | VSHS_UV | VSHS_OV | VCC2_OT | VCC2_UV | VCC1_SC | VCC1_UV_FS | VCC1_UV |
| rc | rc | rc | rc | rc | rc | rc | rc |

| Field | Bits | Type | Description |
|-------------------|------|------|--|
| POR | 7 | rc | Power-On Reset Detection 0 _B , No POR 1 _B , POR occurred |
| VSHS_UV | 6 | rc | VSHS Under-Voltage Detection (V_{SHS,UV}) 0 _B , No VSHS-UV 1 _B , VSHS-UV detected |
| VSHS_OV | 5 | rc | VSHS Over-Voltage Detection (V_{SHS,OV}) 0 _B , No VSHS-OV 1 _B , VSHS-OV detected |
| VCC2_OT | 4 | rc | VCC2 Over Temperature Detection 0 _B , No over temperature 1 _B , VCC2 over temperature detected |
| VCC2_UV | 3 | rc | VCC2 Under Voltage Detection (V_{CC2,UV,t}) 0 _B , No VCC2 Under voltage 1 _B , VCC2 under voltage detected |
| VCC1_SC | 2 | rc | VCC1 Short to GND Detection (<V_{rTx} for t>4ms after switch on) 0 _B , No short 1 _B , VCC1 short to GND detected |
| VCC1_UV_FS | 1 | rc | VCC1 UV-Detection (due to V_{rTx} reset) 0 _B , No Fail-Safe Mode entry due to 4th consecutive VCC1_UV 1 _B , Fail-Safe Mode entry due to 4th consecutive VCC1_UV |
| VCC1_UV | 0 | rc | VCC1 UV-Detection (due to V_{rTx} reset) 0 _B , No VCC1_UV detection 1 _B , VCC1 UV-Fail detected |

Notes

1. The MSB of the POR/Soft Reset value is marked as 'y': the default value of the POR bit is set after Power-on reset (POR value = 1000 0000). However it will be cleared after a SBC Soft Reset command (Soft Reset value = 0000 0000).
2. During Sleep Mode, the bits VCC1_SC, VCC1_OV and VCC1_UV will not be set when VCC1 is off
3. The VCC1_UV bit is never updated in SBC Restart Mode, in SBC Init Mode it is only updated after RO was released for the first time, it is always updated in SBC Normal and Stop Mode, and it is always updated in any SBC modes in a VCC1_SC condition (after VCC1_UV = 1 for >4ms).

THERM_STAT

Thermal Protection Status (Address 100 0010_B)

POR / Soft Reset Value: 0000 0000_B; Restart Value: 0000 0xxx_B

| | | | | | | | |
|----------|----------|----------|----------|----------|------|------|-----|
| 7 | 6 | 5 | 4 | 3 | 2 | 1 | 0 |
| Reserved | Reserved | Reserved | Reserved | Reserved | TSD2 | TSD1 | TPW |
| r | r | r | r | r | rc | rc | rc |

| Field | Bits | Type | Description |
|----------|------|------|--|
| Reserved | 7:3 | r | Reserved, always reads as 0 |
| TSD2 | 2 | rc | TSD2 Thermal Shut-Down Detection 0 _B , No TSD2 event 1 _B , TSD2 OT detected - leading to SBC Fail-Safe Mode |
| TSD1 | 1 | rc | TSD1 Thermal Shut-Down Detection 0 _B , No TSD1 fail 1 _B , TSD1 OT detected |
| TPW | 0 | rc | Thermal Pre Warning 0 _B , No Thermal Pre warning 1 _B , Thermal Pre warning detected |

Note: TSD1 and TSD2 are not reset automatically, even if the temperature pre warning or TSD1 OT condition is not present anymore. Also TSD2 is not reset.

DEV_STAT

Device Information Status (Address 100 0011_B)

POR / Soft Reset Value: 0000 0000_B; Restart Value: xx00 xxxx_B

| | | | | | | | |
|------------|------------|----------|----------|-----------|-----------|----------|---------|
| 7 | 6 | 5 | 4 | 3 | 2 | 1 | 0 |
| DEV_STAT_1 | DEV_STAT_0 | Reserved | Reserved | WD_FAIL_1 | WD_FAIL_0 | SPI_FAIL | FAILURE |
| rc | rc | r | r | rh | rh | rc | rc |

| Field | Bits | Type | Description |
|----------|------|------|---|
| DEV_STAT | 7:6 | rc | Device Status before Restart Mode 00 _B , Cleared (Register must be actively cleared) 01 _B , Restart due to failure (WD fail, TSD2, VCC1_UV); also after a wake from Fail-Safe Mode 10 _B , Sleep Mode 11 _B , Reserved |
| Reserved | 5:4 | r | Reserved, always reads as 0 |
| WD_FAIL | 3:2 | rh | Number of WD-Failure Events (1/2 WD failures depending on CFG) 00 _B , No WD Fail 01 _B , 1x WD Fail, FOx activation - Config 2 selected 10 _B , 2x WD Fail, FOx activation - Config 1 / 3 / 4 selected 11 _B , Reserved (never reached) |
| SPI_FAIL | 1 | rc | SPI Fail Information 0 _B , No SPI fail 1 _B , Invalid SPI command detected |
| FAILURE | 0 | rc | Activation of Fail Output FO 0 _B , No Failure 1 _B , Failure occurred |

Notes

1. The bits **DEV_STAT** show the status of the device before it went through Restart. Either the device came from regular Sleep Mode ('10') or a failure ('01' - SBC Restart or SBC Fail-Safe Mode: WD fail, TSD2 fail, VCC_UV fail or VCC1_OV if bit **VCC1_OV_RST** is set) occurred. Failure is also an illegal command from SBC Stop to SBC Sleep Mode or going to SBC Sleep Mode without activation of any wake source. Coming from SBC Sleep Mode ('10') will also be shown if there was a trial to enter SBC Sleep Mode without having cleared all wake flags before.
2. The **WD_FAIL** bits are configured as a counter and are the only status bits, which are cleared automatically by the SBC. They are cleared after a successful watchdog trigger and when the watchdog is stopped (also in SBC Sleep and Fail-Safe Mode unless it was reached due to a watchdog failure). See also **Chapter 12.1**.
3. The **SPI_FAIL** bit is cleared only by SPI command
4. In case of Config 2/4 the **WD_Fail** counter is frozen in case of WD trigger failure until a successful WD trigger.
5. If **CFG = '0'** then a 1st watchdog failure will not trigger the **FO** outputs or the **FAILURE** bit but only force the SBC into SBC Restart Mode.

BUS_STAT_1

Bus Communication Status (Address 100 0100_B)

POR / Soft Reset Value: 0000 0000_B; Restart Value: 0000 0xxx_B

| | | | | | | | |
|----------|----------|----------|----------|----------|------------|------------|---------|
| 7 | 6 | 5 | 4 | 3 | 2 | 1 | 0 |
| Reserved | Reserved | Reserved | Reserved | Reserved | CAN_FAIL_1 | CAN_FAIL_0 | VCAN_UV |
| r | r | r | r | r | rc | rc | rc |

| Field | Bits | Type | Description |
|----------|------|------|--|
| Reserved | 7 | r | Reserved, always reads as 0 |
| Reserved | 6:5 | r | Reserved, always reads as 0 |
| Reserved | 4:3 | r | Reserved, always reads as 0 |
| CAN_FAIL | 2:1 | rc | CAN Failure Status 00 _B , No error 01 _B , CAN TSD 10 _B , CAN_TXD_DOM: TXD dominant time out for more than 4ms 11 _B , CAN_BUS_DOM: BUS dominant time out for more than 4ms |
| VCAN_UV | 0 | rc | Under Voltage CAN Bus Supply 0 _B , Normal operation 1 _B , CAN Supply under voltage detected. Transmitter disabled |

Notes

1. The VCAN_UV comparator is enabled if the mode bit CAN_1 = '1', i.e. in CAN Normal or CAN Receive Only Mode.

WK_STAT_1

Wake-up Source and Information Status (Address 100 0110_B)

POR / Soft Reset Value: 0000 0000_B; Restart Value: 00xx 0xxx_B

| | | | | | | | |
|----------|----------|--------|----------|----------|--------|--------|--------|
| 7 | 6 | 5 | 4 | 3 | 2 | 1 | 0 |
| Reserved | Reserved | CAN_WU | TIMER_WU | Reserved | WK3_WU | WK2_WU | WK1_WU |
| r | r | rc | rc | r | rc | rc | rc |

| Field | Bits | Type | Description |
|----------|------|------|--|
| Reserved | 7 | r | Reserved, always reads as 0 |
| Reserved | 6 | r | Reserved, always reads as 0 |
| CAN_WU | 5 | rc | Wake up via CAN Bus 0 _B , No Wake up 1 _B , Wake up |
| TIMER_WU | 4 | rc | Wake up via TimerX 0 _B , No Wake up 1 _B , Wake up |
| Reserved | 3 | r | Reserved, always reads as 0 |
| WK3_WU | 2 | rc | Wake up via WK3 0 _B , No Wake up 1 _B , Wake up |
| WK2_WU | 1 | rc | Wake up via WK2 0 _B , No Wake up 1 _B , Wake up |
| WK1_WU | 0 | rc | Wake up via WK1 0 _B , No Wake up 1 _B , Wake up |

Note: The respective wake source bit will also be set when the device is woken from SBC Fail-Safe Mode

WK_STAT_2

Wake-up Source and Information Status (Address 100 0111_B)

POR / Soft Reset Value: 0000 0000_B; Restart Value: 00xx 0000_B

| | | | | | | | |
|----------|----------|----------|----------|----------|----------|----------|----------|
| 7 | 6 | 5 | 4 | 3 | 2 | 1 | 0 |
| Reserved | Reserved | GPIO2_WU | GPIO1_WU | Reserved | Reserved | Reserved | Reserved |
| r | r | rc | rc | r | r | r | r |

| Field | Bits | Type | Description |
|----------|------|------|---|
| Reserved | 7:6 | r | Reserved, always reads as 0 |
| GPIO2_WU | 5 | rc | Wake up via GPIO2 0 _B , No Wake up 1 _B , Wake up |
| GPIO1_WU | 4 | rc | Wake up via GPIO1 0 _B , No Wake up 1 _B , Wake up |
| Reserved | 3:0 | r | Reserved, always reads as 0 |

WK_LVL_STAT

WK Input Level (Address 100 1000_B)

POR / Soft Reset Value: xx00 0xxx_B;

Restart Value: xxxx 0xxx_B

| | | | | | | | |
|-------------|------|-----------|-----------|----------|---------|---------|---------|
| 7 | 6 | 5 | 4 | 3 | 2 | 1 | 0 |
| SBC_DEV_LVL | CFGP | GPIO2_LVL | GPIO1_LVL | Reserved | WK3_LVL | WK2_LVL | WK1_LVL |
| r | r | r | r | r | r | r | r |

| Field | Bits | Type | Description |
|-------------|------|------|---|
| SBC_DEV_LVL | 7 | r | Status of SBC Operating Mode at FO3/TEST Pin 0 _B , User Mode activated 1 _B , SBC Software Development Mode activated |
| CFGP | 6 | r | Device Configuration Status 0 _B , No external pull-up resistor connected on INT (Config 2/4) 1 _B , External pull-up resistor connected on INT (Config 1/3) |
| GPIO2_LVL | 5 | r | Status of GPIO2 (if selected as GPIO) 0 _B , Low Level (=0) 1 _B , High Level (=1) |
| GPIO1_LVL | 4 | r | Status of GPIO1 (if selected as GPIO) 0 _B , Low Level (=0) 1 _B , High Level (=1) |
| Reserved | 3 | r | Reserved, always reads as 0 |
| WK3_LVL | 2 | r | Status of WK3 0 _B , Low Level (=0) 1 _B , High Level (=1) |
| WK2_LVL | 1 | r | Status of WK2 0 _B , Low Level (=0) 1 _B , High Level (=1) |
| WK1_LVL | 0 | r | Status of WK1 0 _B , Low Level (=0) 1 _B , High Level (=1) |

Note: GPIOx_LVL is updated in SBC Normal and Stop Mode if configured as wake input, low-side switch or high-side switch.

In cyclic sense or wake mode, the registers contain the sampled level, i.e. the registers are updated after every sampling. The GPIOs are not capable of cyclic sensing.

If selected as GPIO then the respective level is shown even if configured as low-side or high-side.

HS_OC_OT_STAT

High-Side Switch Overload Status (Address 101 0100_B)

POR / Soft Reset Value: 0000 0000_B; Restart Value: 0000 xxxx_B

| | | | | | | | |
|----------|----------|----------|----------|-----------|-----------|-----------|-----------|
| 7 | 6 | 5 | 4 | 3 | 2 | 1 | 0 |
| Reserved | Reserved | Reserved | Reserved | HS4_OC_OT | HS3_OC_OT | HS2_OC_OT | HS1_OC_OT |
| r | r | r | r | rc | rc | rc | rc |

| Field | Bits | Type | Description |
|-----------|------|------|--|
| Reserved | 7:4 | r | Reserved, always reads as 0 |
| HS4_OC_OT | 3 | rc | Over-Current & Over-Temperature Detection HS4 0 _B , No OC or OT 1 _B , OC or OT detected |
| HS3_OC_OT | 2 | rc | Over-Current & Over-Temperature Detection HS3 0 _B , No OC or OT 1 _B , OC or OT detected |
| HS2_OC_OT | 1 | rc | Over-Current & Over-Temperature Detection HS2 0 _B , No OC or OT 1 _B , OC or OT detected |
| HS1_OC_OT | 0 | rc | Over-Current & Over-Temperature Detection HS1 0 _B , No OC or OT 1 _B , OC or OT detected |

Note: The OC/OT bit might be set for $V_{POR,f} < V_S < 5.5V$ (see also [Chapter 4.2](#))

HS_OL_STAT

High-Side Switch Open-Load Status (Address 101 0101_B)

POR / Soft Reset Value: 0000 0000_B; Restart Value: 0000 xxxx_B

| | | | | | | | |
|----------|----------|----------|----------|--------|--------|--------|--------|
| 7 | 6 | 5 | 4 | 3 | 2 | 1 | 0 |
| Reserved | Reserved | Reserved | Reserved | HS4_OL | HS3_OL | HS2_OL | HS1_OL |
| r | r | r | r | rc | rc | rc | rc |

| Field | Bits | Type | Description |
|----------|------|------|--|
| Reserved | 7:4 | r | Reserved, always reads as 0 |
| HS4_OL | 3 | rc | Open-Load Detection HS4 0 _B , No OL 1 _B , OL detected |
| HS3_OL | 2 | rc | Open-Load Detection HS3 0 _B , No OL 1 _B , OL detected |
| HS2_OL | 1 | rc | Open-Load Detection HS2 0 _B , No OL 1 _B , OL detected |
| HS1_OL | 0 | rc | Open-Load Detection HS1 0 _B , No OL 1 _B , OL detected |

14.6.2 Family and Product Information Register

FAM_PROD_STAT

Family and Product Identification Register (Address 111 1110_B)

POR / Soft Reset Value: 0011 yyyy_B; Restart Value: 0011 yyyy_B

| | | | | | | | |
|-------|-------|-------|-------|--------|--------|--------|--------|
| 7 | 6 | 5 | 4 | 3 | 2 | 1 | 0 |
| FAM_3 | FAM_2 | FAM_1 | FAM_0 | PROD_3 | PROD_2 | PROD_1 | PROD_0 |
| r | r | r | r | r | r | r | r |

| Field | Bits | Type | Description |
|-------------|------|------|---|
| FAM | 7:4 | r | SBC Family Identifier (bit4=LSB; bit7=MSB) 0 0 01 _B , Driver SBC Family 0 0 10 _B , DC/DC-SBC Family 0 0 11 _B , Mid-Range SBC Family x x x x _B , reserved for future products |
| PROD | 3:0 | r | SBC Product Identifier (bit0=LSB; bit3=MSB) 0 0 0 0 _B , TLE9260QX (5V, no LIN, no VCC3, no SWK) 0 1 0 0 _B , TLE9261QX (5V, no LIN, VCC3, no SWK) 1 0 0 0 _B , TLE9262QX (5V, 1 LIN, VCC3, no SWK) 1 1 0 0 _B , TLE9263QX (5V, 2 LIN, VCC3, no SWK) |

Notes

1. The actual default register value after POR, Soft Reset or Restart of PROD will depend on the respective product. Therefore the value 'y' is specified.
2. SWK = Selective Wake feature in CAN Partial Networking standard

14.7 Electrical Characteristics
Table 23 Electrical Characteristics

$V_S = 5.5\text{ V to }28\text{ V}$, $T_j = -40\text{ °C to }+150\text{ °C}$, all voltages with respect to ground, positive current flowing into pin (unless otherwise specified)

| Parameter | Symbol | Values | | | Unit | Note / Test Condition | Number |
|---|-----------------------|--------------------------|---------------------------|--------------------------|---------------|--|-----------|
| | | Min. | Typ. | Max. | | | |
| SPI frequency | | | | | | | |
| Maximum SPI frequency | $f_{\text{SPI,max}}$ | – | – | 4.0 | MHz | ¹⁾ | P_16.7.1 |
| SPI Interface; Logic Inputs SDI, CLK and CSN | | | | | | | |
| H-input Voltage Threshold | V_{IH} | – | – | 0.7* V_{CC1} | V | – | P_16.7.2 |
| L-input Voltage Threshold | V_{IL} | 0.3* V_{CC1} | – | – | V | – | P_16.7.3 |
| Hysteresis of input Voltage | V_{IHY} | – | 0.12* V_{CC1} | – | V | ¹⁾ | P_16.7.4 |
| Pull-up Resistance at pin CSN | R_{ICSN} | 20 | 40 | 80 | k Ω | $V_{\text{CSN}} = 0.7 \times V_{\text{CC1}}$ | P_16.7.5 |
| Pull-down Resistance at pin SDI and CLK | $R_{\text{ICLK/SDI}}$ | 20 | 40 | 80 | k Ω | $V_{\text{SDI/CLK}} = 0.2 \times V_{\text{CC1}}$ | P_16.7.6 |
| Input Capacitance at pin CSN, SDI or CLK | C_1 | – | 10 | – | pF | ¹⁾ | P_16.7.7 |
| Logic Output SDO | | | | | | | |
| H-output Voltage Level | V_{SDOH} | $V_{\text{CC1}} - 0.4$ | $V_{\text{CC1}} - 0.2$ | – | V | $I_{\text{DOH}} = -1.6\text{ mA}$ | P_16.7.8 |
| L-output Voltage Level | V_{SDOL} | – | 0.2 | 0.4 | V | $I_{\text{DOL}} = 1.6\text{ mA}$ | P_16.7.9 |
| Tristate Leakage Current | I_{SDOLK} | -10 | – | 10 | μA | $V_{\text{CSN}} = V_{\text{CC1}}$; $0\text{ V} < V_{\text{DO}} < V_{\text{CC1}}$ | P_16.7.10 |
| Tristate Input Capacitance | C_{SDO} | – | 10 | 15 | pF | ¹⁾ | P_16.7.11 |
| Data Input Timing¹⁾ | | | | | | | |
| Clock Period | t_{pCLK} | 250 | – | – | ns | – | P_16.7.12 |
| Clock High Time | t_{CLKH} | 125 | – | – | ns | – | P_16.7.13 |
| Clock Low Time | t_{CLKL} | 125 | – | – | ns | – | P_16.7.14 |
| Clock Low before CSN Low | t_{bef} | 125 | – | – | ns | – | P_16.7.15 |
| CSN Setup Time | t_{lead} | 250 | – | – | ns | – | P_16.7.16 |
| CLK Setup Time | t_{lag} | 250 | – | – | ns | – | P_16.7.17 |
| Clock Low after CSN High | t_{beh} | 125 | – | – | ns | – | P_16.7.18 |
| SDI Set-up Time | t_{DISU} | 100 | – | – | ns | – | P_16.7.19 |
| SDI Hold Time | t_{DIHO} | 50 | – | – | ns | – | P_16.7.20 |
| Input Signal Rise Time at pin SDI, CLK and CSN | t_{rIN} | – | – | 50 | ns | – | P_16.7.21 |
| Input Signal Fall Time at pin SDI, CLK and CSN | t_{fIN} | – | – | 50 | ns | – | P_16.7.22 |
| Delay Time for Mode Changes ²⁾ | $t_{\text{Del,Mode}}$ | – | – | 6 | μs | includes internal oscillator tolerance | P_16.7.23 |

Table 23 Electrical Characteristics (cont'd)

$V_S = 5.5\text{ V to }28\text{ V}$, $T_j = -40\text{ °C to }+150\text{ °C}$, all voltages with respect to ground, positive current flowing into pin (unless otherwise specified)

| Parameter | Symbol | Values | | | Unit | Note / Test Condition | Number |
|--|-----------------|--------|------|------|---------------|-----------------------|-----------|
| | | Min. | Typ. | Max. | | | |
| CSN High Time | $t_{CSN(high)}$ | 3 | – | – | μs | – | P_16.7.24 |
| Data Output Timing¹⁾ | | | | | | | |
| SDO Rise Time | t_{rSDO} | – | 30 | 80 | ns | $C_L = 100\text{ pF}$ | P_16.7.25 |
| SDO Fall Time | t_{fSDO} | – | 30 | 80 | ns | $C_L = 100\text{ pF}$ | P_16.7.26 |
| SDO Enable Time | t_{ENSDO} | – | – | 50 | ns | low impedance | P_16.7.27 |
| SDO Disable Time | t_{DISSDO} | – | – | 50 | ns | high impedance | P_16.7.28 |
| SDO Valid Time | t_{VASDO} | – | – | 50 | ns | $C_L = 100\text{ pF}$ | P_16.7.29 |

- 1) Not subject to production test; specified by design
- 2) Applies to all mode changes triggered via SPI commands

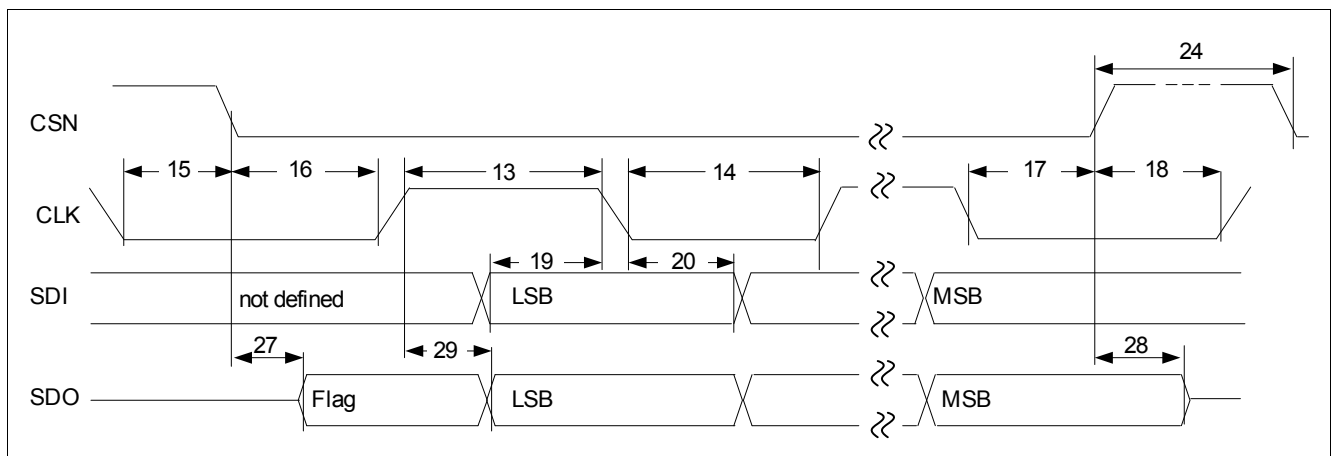

Figure 46 SPI Timing Diagram

Note: Numbers in drawing correlate to the last 2 digits of the Number field in the Electrical Characteristics table.

15 Application Information

15.1 Application Diagram

Note: The following information is given as a hint for the implementation of the device only and shall not be regarded as a description or warranty of a certain functionality, condition or quality of the device.

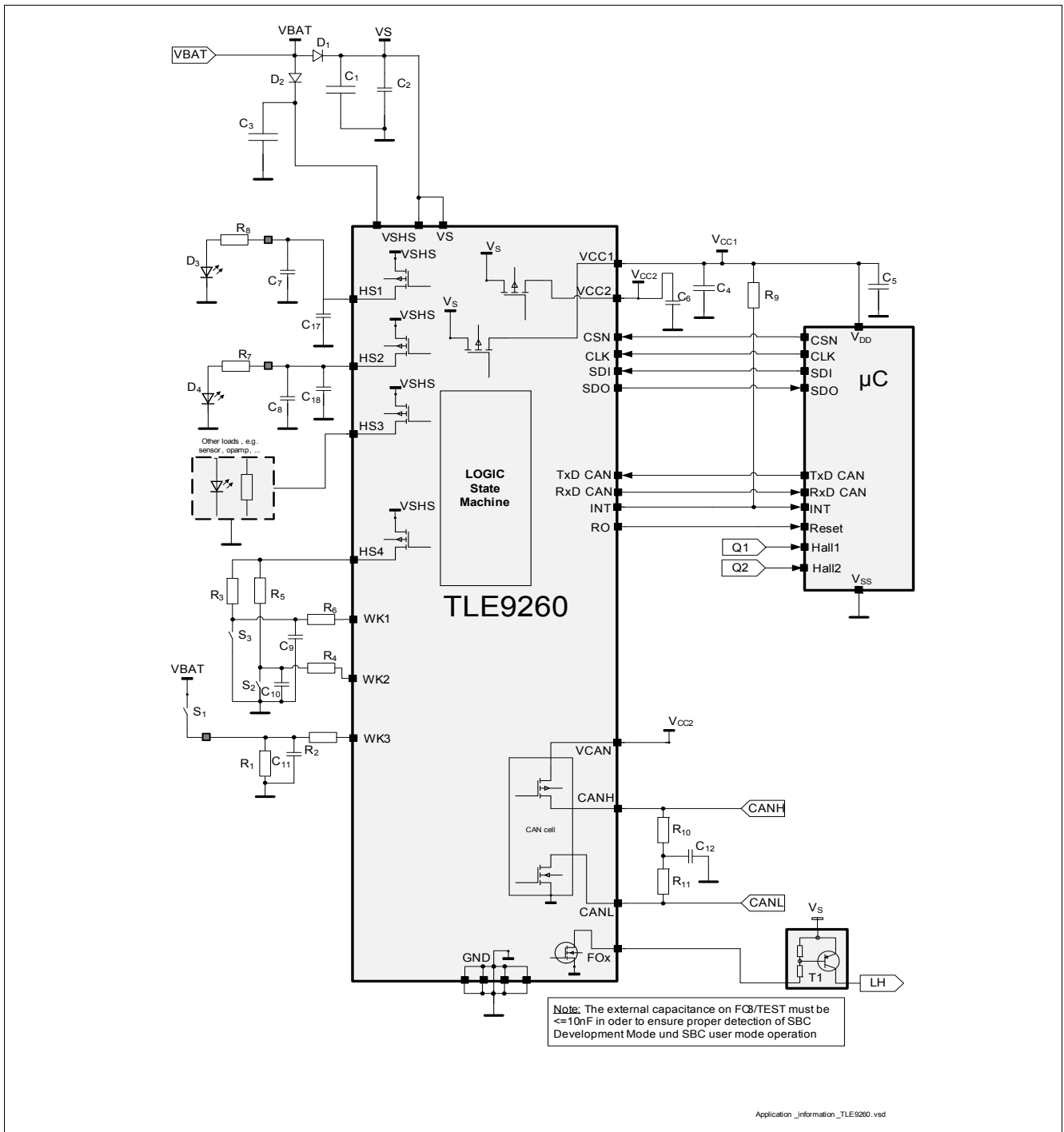

Figure 47 Simplified Application Diagram

Note: Unused outputs are recommended to be left unconnected on the application board. If unused output pins are routed to an external connector which leaves the ECU, then these pins should have provision for a zero ohm jumper (depopulated if unused) or ESD protection.

Table 24 Bill of Material for Simplified Application Diagram

| Ref. | Typical Value | Purpose / Comment |
|---------------------|-----------------------|---|
| Capacitances | | |
| C1 | 68µF | Buffering capacitor to cut off battery spikes, depending on application |
| C2 | 100nF | EMC, blocking capacitor |
| C3 | 22µF | Buffering capacitor to cut off battery spikes from VSHS as separate supply input; Depending on application, only needed if VSHS is not connected to VS; |
| C4 | 2.2µF low ESR | As required by application, min. 470nF for stability |
| C5 | 100nF ceramic | Spike filtering, improve stability of supply for microcontroller; not needed for SBC |
| C6 | 2.2µF low ESR | Blocking capacitor, min. 470nF for stability; if used for CAN supply place a 100nF ceramic capacitor in addition very close to VCAN pin for optimum EMC behavior |
| C7 | 33nF | As required by application, mandatory protection for off-board connections |
| C8 | 33nF | As required by application, mandatory protection for off-board connections |
| C17 | 47pF | Only required in case of off-board connection to optimize EMC behavior, place close to pin |
| C18 | 47pF | Only required in case of off-board connection to optimize EMC behavior, place close to pin |
| C9 | 10nF | Spike filtering, as required by application, mandatory protection for off-board connections (see also Simplified Application Diagram with the Alternate Measurement Function) |
| C10 | 10nF | Spike filtering, as required by application, mandatory protection for off-board connections |
| C11 | 10nF | Spike filtering, as required by application, mandatory protection for off-board connections |
| C12 | 4.7nF / OEM dependent | Split termination stability |

Table 24 Bill of Material for Simplified Application Diagram (cont'd)

| Ref. | Typical Value | Purpose / Comment |
|--------------------------|--|---|
| Resistances | | |
| R1 | 10kΩ | Wetting current of the switch, as required by application |
| R2 | 10kΩ | Limit the WK pin current, e.g. for ISO pulses |
| R3 | 10kΩ | Wetting current of the switch, as required by application |
| R4 | 10kΩ | Limit the WK pin current, e.g. for ISO pulses |
| R5 | 10kΩ | Wetting current of the switch, as required by application |
| R6 | 10kΩ | Limit the WK pin current, e.g. for ISO pulses |
| R7 | depending on LED config. | LED current limitation, as required by application |
| R8 | depending on LED config. | LED current limitation, as required by application |
| R9 | 47kΩ | Selection of hardware configuration 1/3, i.e. in case of WD failure SBC Restart Mode is entered. If not connected, then hardware configuration 2/4 is selected |
| R10 | 60Ω / OEM dependent | CAN bus termination |
| R11 | 60Ω / OEM dependent | CAN bus termination |
| R15 | 10kΩ | WK1 pin current limitation, e.g. for ISO pulses, for alternate measurement function (see also Simplified Application Diagram with the Alternate Measurement Function) |
| R16 | depending on application and microcontroller | Voltage Divider resistor to adjust measurement voltage to microcontroller ADC input range (see also Simplified Application Diagram with the Alternate Measurement Function) |
| R17 | depending on application and microcontroller | Voltage Divider resistor to adjust measurement voltage to microcontroller ADC input range (see also Simplified Application Diagram with the Alternate Measurement Function) |
| Active Components | | |
| D1 | e.g. BAS 3010A, Infineon | Reverse polarity protection for VS supply pins |
| D2 | e.g. BAS 3010A, Infineon | Reverse polarity protection for VSHS supply pin; if separate supplies are not needed, then connect VSHS to VS pins |
| D3 | LED | As required by application, configure series resistor accordingly |
| D4 | LED | As required by application, configure series resistor accordingly |
| T1 | e.g. BCR191W | High active FO control |
| μC | e.g. TC2xxx | Microcontroller |

Note: This is a simplified example of an application circuit. The function must be verified in the real application.

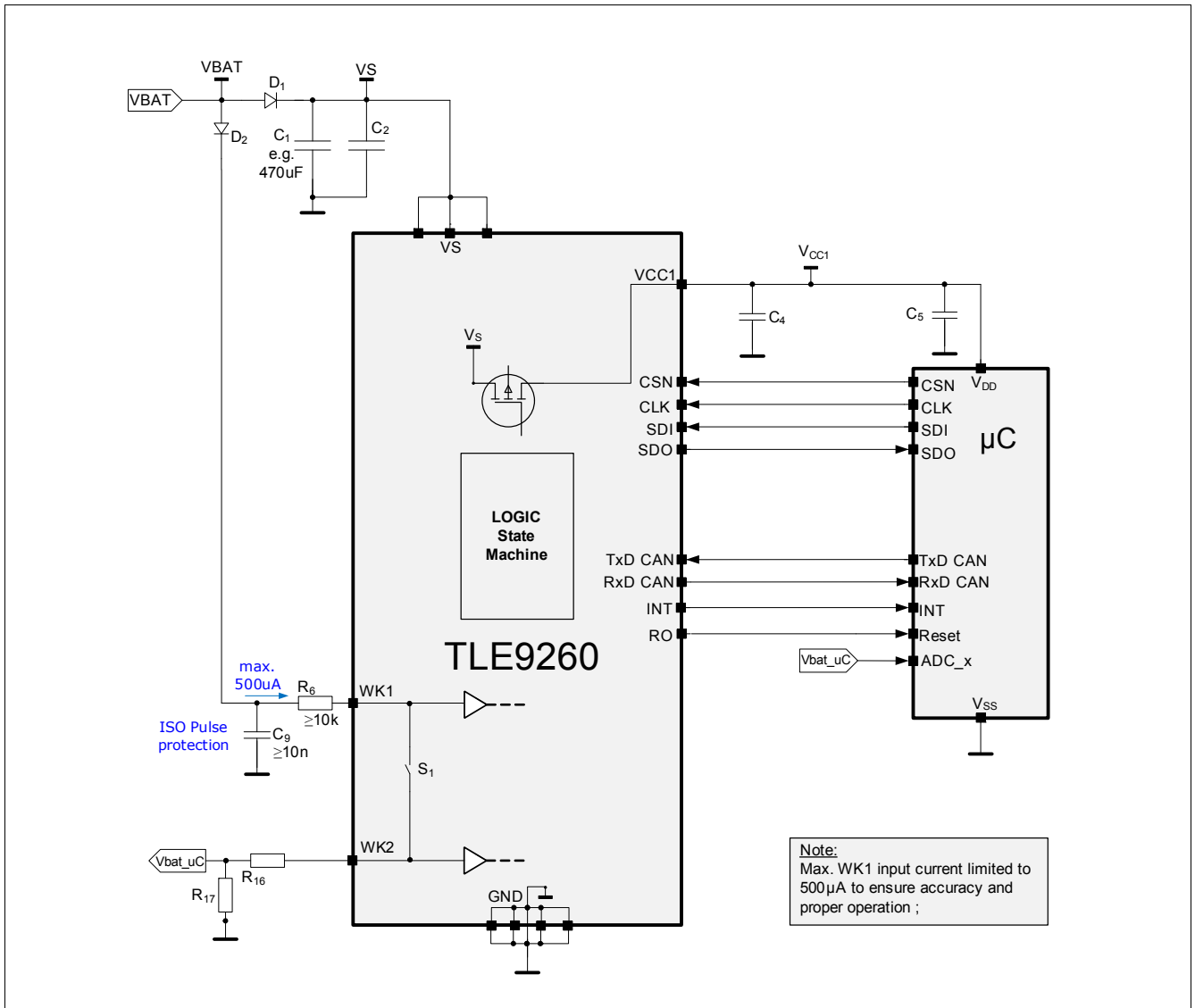

Figure 48 Simplified Application Diagram with the Alternate Measurement Function via WK1 and WK2

Note: This is a very simplified example of an application circuit. The function must be verified in the real application. WK1 must be connected to signal to be measured and WK2 is the output to the microcontroller supervision function. The maximum current into WK1 must be <math><500\mu\text{A}</math>. The minimum current into WK1 should be >math>>5\mu\text{A}</math> to ensure proper operation.

15.2 ESD Tests

Note: Tests for ESD robustness according to IEC61000-4-2 “gun test” (150pF, 330Ω) will be performed. The results and test condition will be available in a test report. The target values for the test are listed in [Table 25](#) below.

Table 25 ESD “Gun Test”

| Performed Test | Result | Unit | Remarks |
|---|--------|------|--------------------------------|
| ESD at pin CANH, CANL, VS, WK1..3, HSx, VCC2 versus GND | >6 | kV | ¹⁾²⁾ positive pulse |
| ESD at pin CANH, CANL, VS, WK1..3, HSx, VCC2 versus GND | < -6 | kV | ¹⁾²⁾ negative pulse |

1)ESD Test “Gun Test” is specified with external components for pins VS, WK1..3, HSx and VCC2. See the application diagram in [Chapter 15.1](#) for more information.

2) ESD susceptibility “ESD GUN” according LIN EMC 1.3 Test Specification, Section 4.3 (IEC 61000-4-2). Tested by external test house (IBEE Zwickau, EMC Test report Nr. 07-10-13)

EMC and ESD susceptibility tests according to SAE J2962-2 (2010) have been performed. Tested by external test house (UL LLC, Test report Nr. 2013-474A)

15.3 Thermal Behavior of Package

Below figure shows the thermal resistance (R_{th_JA}) of the device vs. the cooling area on the bottom of the PCB for $T_a = 85^\circ\text{C}$. Every line reflects a different PCB and thermal via design.

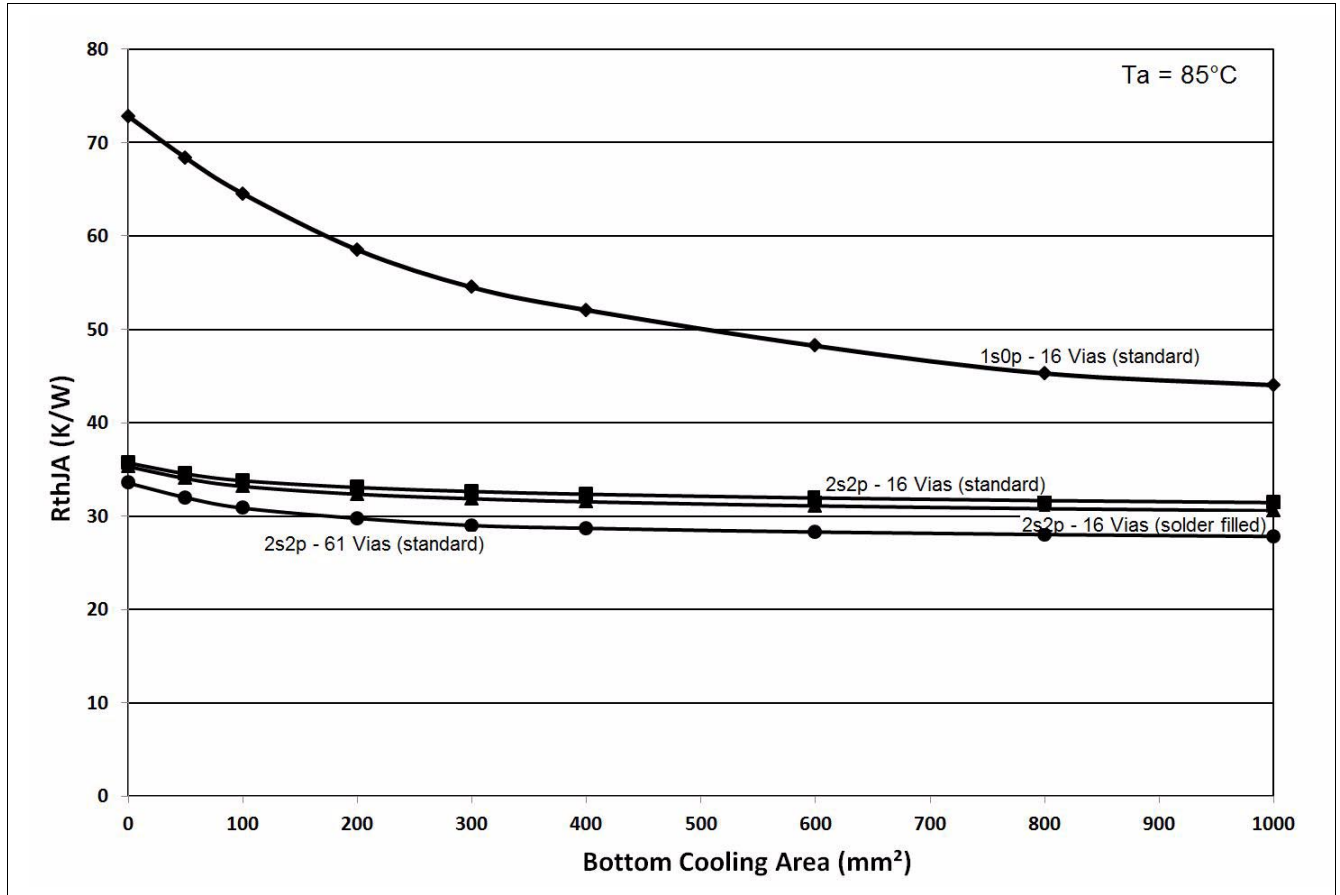

Figure 49 Thermal Resistance (R_{th_JA}) vs. Cooling Area

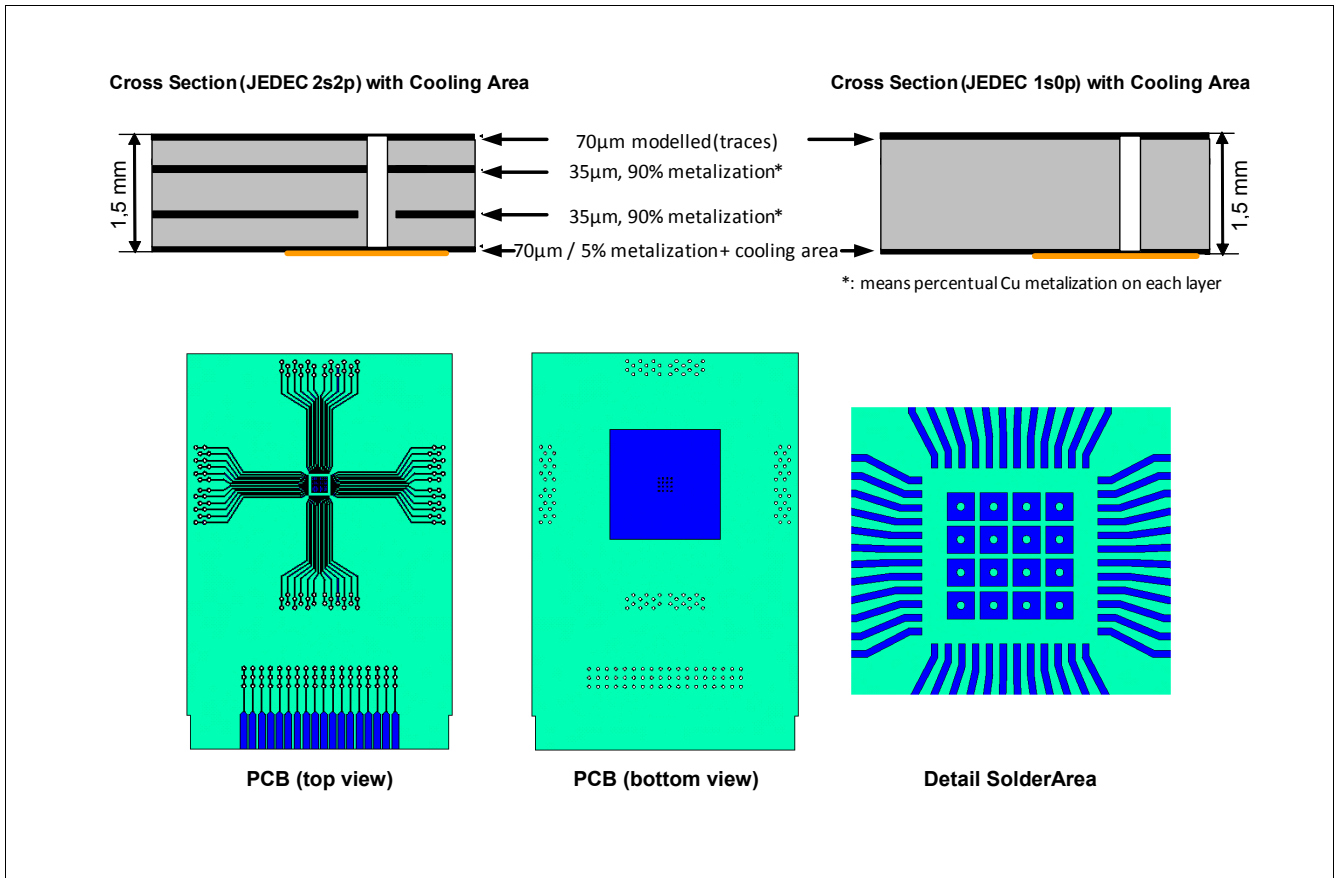

Figure 50 Board Setup

Board setup is defined according to JESD 51-2,-5,-7.

Board: 76.2x114.3x1.5mm³ with 2 inner copper layers (35µm thick), with thermal via array under the exposed pad contacting the first inner copper layer and 300mm² cooling area on the bottom layer (70µm).

17 Revision History

Table 26 Revision History

| Revision | Date | Changes |
|----------|------------|-----------------|
| Rev 1.1 | 2014-09-26 | Initial Release |

Edition 2014-09-26

**Published by
Infineon Technologies AG
81726 Munich, Germany**

**© 2014 Infineon Technologies AG
All Rights Reserved.**

Legal Disclaimer

The information given in this document shall in no event be regarded as a guarantee of conditions or characteristics. With respect to any examples or hints given herein, any typical values stated herein and/or any information regarding the application of the device, Infineon Technologies hereby disclaims any and all warranties and liabilities of any kind, including without limitation, warranties of non-infringement of intellectual property rights of any third party.

Information

For further information on technology, delivery terms and conditions and prices, please contact the nearest Infineon Technologies Office (www.infineon.com).

Warnings

Due to technical requirements, components may contain dangerous substances. For information on the types in question, please contact the nearest Infineon Technologies Office.

Infineon Technologies components may be used in life-support devices or systems only with the express written approval of Infineon Technologies, if a failure of such components can reasonably be expected to cause the failure of that life-support device or system or to affect the safety or effectiveness of that device or system. Life support devices or systems are intended to be implanted in the human body or to support and/or maintain and sustain and/or protect human life. If they fail, it is reasonable to assume that the health of the user or other persons may be endangered.