

AN6154NK, AN6154NS

Speech Network IC

Overview

The AN6154NK and AN6154NS are speech network circuits capable of switching side-tone preventive networks. They incorporate an ECM power supply (typically 1.3 V), and are operable at as low as 1.8 V.

Features

- Operable at as low as a 1.8 V line voltage.
- Incorporates an ECM power supply for easier interface with peripheral devices.
- Automatically adjusts the transmitter/receiver gain according to line current.
- Can select one of two side-tone preventive networks according to line current.
- Selection of side-tone preventive networks and control of the transmitter/receiver gain are possible from outside.
- The receiver gain is switchable between 0 and 6 dB.

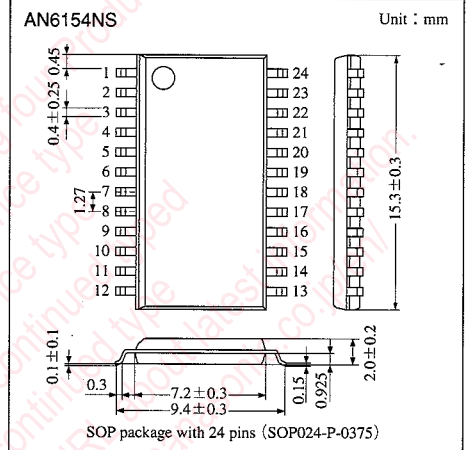
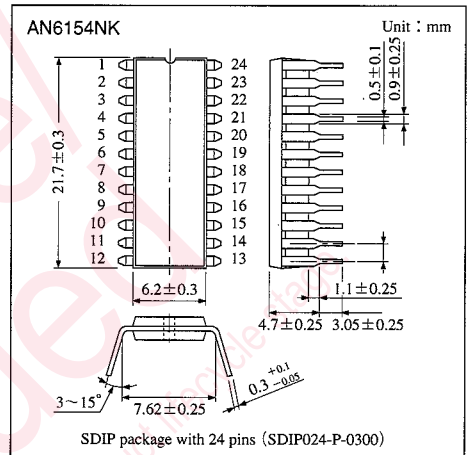

Block Diagram

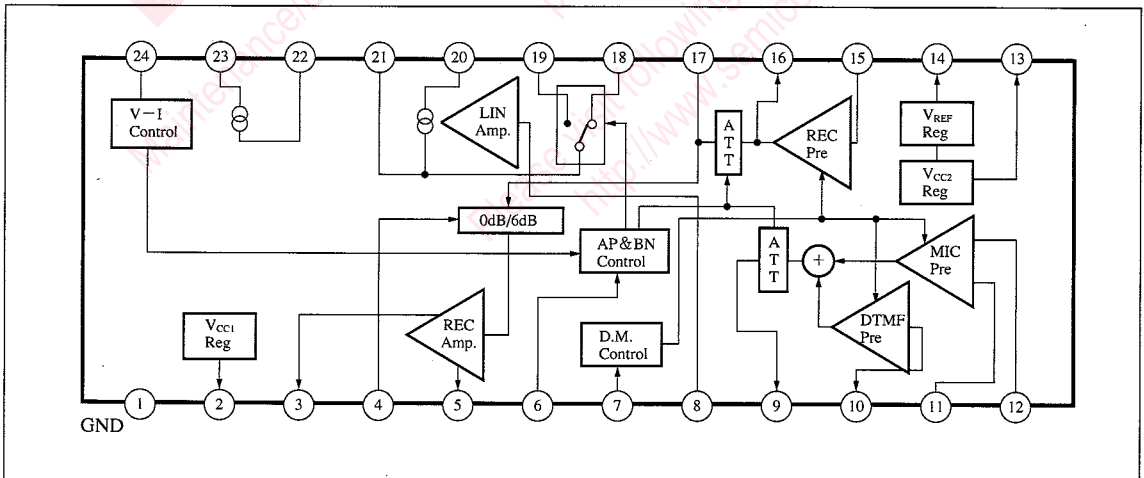

Absolute Maximum Ratings (Ta=25°C)

Parameter	Symbol	Rating	Unit
Supply voltage *1	V _L	14.4	V
Supply current *1	I _L	120	mA
Internal supply current *3	I _{CC1}	20	mA
APC voltage *4	V ₆	V _{CC1} +0.3V	V
DMC voltage *4	V ₇	V _{CC1} +0.3V	V
Power dissipation *2 (Ta=60°C)	AN6154NK	700	mW
	AN6154NS	338	
Operating ambient temperature	T _{opr}	-20 to +75	°C
Storage temperature	T _{stg}	-55 to +125	°C

*1 V_L and I_L are input voltage and current measured at pin 21 respectively.

*2 The P_D rating must be observed.

*3 I_{CC1} is the line current measured at pin 2. No voltage other than the line voltage must be applied to this pin.

*4 V_{CC1} is the line voltage measured at pin 2.

Recommended Operating Range (Ta=25°C)

Parameter	Symbol	Range
Operating supply voltage range	V _L	3V~11.5V

Electrical Characteristics (Ta=25°C)

Parameter	Symbol	Condition	min.	typ.	max.	Unit
Receiver system						
Receiver gain	G _{V-R}	I _L =30mA, V _i =-40dBV	31.5	34	36.5	dB
Receiver automatic pad	A _{P-R}	I _L =80mA to 30mA, V _i =-40dBV	-6.8	-5.3	-3.8	dB
Receiver gain control	G _{V-d}	I _L =30mA, V _i =-40dBV	5	6	7	dB
Maximum receiver signal level	V _{O-R}	I _L =30mA, THD=5%	-1	2	—	dBV
KEY-IN TONE gain	G _{V-KT}	I _L =30mA, V _i =-30dBV	14.5	17	19.5	dB
Transmitter system						
Transmitter gain	G _{V-T}	I _L =30mA, V _i =-50dBV	37.5	40	42.5	dB
Transmitter automatic pad	A _{P-T}	ΔI _L =80mA to 30mA, V _i =-50dBV	-4.8	-3.5	-2.1	dB
Maximum output	V _{O-T}	I _L =30mA, THD=5%	-2	1.3	—	dBV
DTMF gain	G _{V-DT}	I _L =30mA, V _i =-50dBV	30	32	34	dB
DTMF automatic pad	A _{P-DT}	ΔI _L =80mA to 30mA, V _i =-50dBV	-4.8	-3.4	-2.1	dB
Maximum DTMF output	V _{O-DT}	I _L =30mA, THD=5%	-2	1.3	—	dBV
Power supply						
DC line voltage (1)	V _{L-1}	I _L =20mA	3	3.5	4	V
DC line voltage (2)	V _{L-2}	I _L =120mA	6.3	6.8	7.3	V
Internal supply voltage (1)	V _{CC1-1}	I _L =20mA	2.2	2.45	2.7	V
Internal supply voltage (2)	V _{CC1-2}	I _L =120mA	2.2	2.45	2.7	V
Internal supply voltage (1)	V _{CC2-1}	I _L =20mA	1.1	1.3	1.5	V
Internal supply voltage (2)	V _{CC2-2}	I _L =20mA	1.1	1.3	1.5	V
Dial mute input						
Dial mute OFF	V _{DM-H}		0.9	—	V _{CC1}	V
Dial mute ON	V _{DM-L}		—	—	0.3	V
AP control						
BN-1 ON	I _{L-BN1}		—	54	61	mA
BN-2 ON	I _{L-BN2}		40	46	—	mA

Note) Unless otherwise specified, input signal frequency (f_{in}) is 1 kHz.

ICs for
Telephone

■ Application Circuit

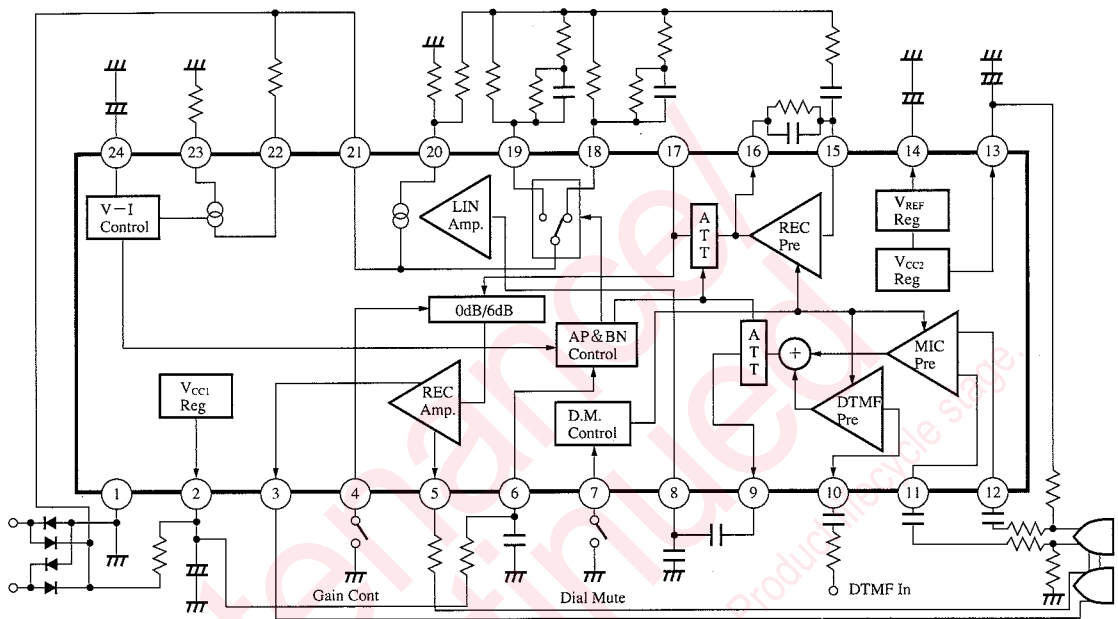

■ Pin Descriptions

Pin No.	Description	Pin No.	Description
1	Ground	13	Regulated power supply (2) Output
2	Regulated power supply (1) Output	14	Reference voltage output
3	Receiver output (1)	15	Receiver preamplifier input
4	Receiver gain switching control	16	Receiver preamplifier output
5	Receiver output (2)	17	To a receiver output amplifier
6	AP/BN switching control	18	To a long-distance side-tone preventive network (BN1)
7	Dial muting control	19	To a short-distance side-tone preventive network (BN2)
8	Line amplifier input	20	Side-tone adjustment
9	Transmitter preamplifier output	21	To the positive line
10	DTMF input	22	Line current bypass (2)
11	Transmitter input (1)	23	Line current bypass (1)
12	Transmitter input (2)	24	Line voltage control

■ Supplementary Explanation

● Designed Electrical Characteristics (Ta=25°C)

Parameter	Symbol	Condition	min.	typ.	max.	Unit
AC impedance (1)	Z _{AC-1}	I _L = 30mA, Fin = 1kHz	400	650	800	Ω
AC impedance (2)	Z _{AC-2}	I _L = 80mA, Fin = 1kHz	400	610	800	Ω

Request for your special attention and precautions in using the technical information and semiconductors described in this book

- (1) If any of the products or technical information described in this book is to be exported or provided to non-residents, the laws and regulations of the exporting country, especially, those with regard to security export control, must be observed.
- (2) The technical information described in this book is intended only to show the main characteristics and application circuit examples of the products. No license is granted in and to any intellectual property right or other right owned by Panasonic Corporation or any other company. Therefore, no responsibility is assumed by our company as to the infringement upon any such right owned by any other company which may arise as a result of the use of technical information described in this book.
- (3) The products described in this book are intended to be used for standard applications or general electronic equipment (such as office equipment, communications equipment, measuring instruments and household appliances).
Consult our sales staff in advance for information on the following applications:
 - Special applications (such as for airplanes, aerospace, automobiles, traffic control equipment, combustion equipment, life support systems and safety devices) in which exceptional quality and reliability are required, or if the failure or malfunction of the products may directly jeopardize life or harm the human body.
 - Any applications other than the standard applications intended.
- (4) The products and product specifications described in this book are subject to change without notice for modification and/or improvement. At the final stage of your design, purchasing, or use of the products, therefore, ask for the most up-to-date Product Standards in advance to make sure that the latest specifications satisfy your requirements.
- (5) When designing your equipment, comply with the range of absolute maximum rating and the guaranteed operating conditions (operating power supply voltage and operating environment etc.). Especially, please be careful not to exceed the range of absolute maximum rating on the transient state, such as power-on, power-off and mode-switching. Otherwise, we will not be liable for any defect which may arise later in your equipment.
 - Even when the products are used within the guaranteed values, take into the consideration of incidence of break down and failure mode, possible to occur to semiconductor products. Measures on the systems such as redundant design, arresting the spread of fire or preventing glitch are recommended in order to prevent physical injury, fire, social damages, for example, by using the products.
- (6) Comply with the instructions for use in order to prevent breakdown and characteristics change due to external factors (ESD, EOS, thermal stress and mechanical stress) at the time of handling, mounting or at customer's process. When using products for which damp-proof packing is required, satisfy the conditions, such as shelf life and the elapsed time since first opening the packages.
- (7) This book may be not reprinted or reproduced whether wholly or partially, without the prior written permission of our company.