

## Ambient Light Sensor – Surface Mount ALS-PDIC17-77C/TR8

### Features

- Close responsively to the human eye spectrum
- Light to Current, analog output
- Good output linearity across wide illumination range
- Low sensitivity variation across various light sources
- Operating temperature performance, -40°C to 85°C
- Wide supply voltage range, 1.8V to 5.5V
- Size : 1.6mm(L)\*1.6mm(W)\*0.55mm(H)
- RoHS compliant, Pb Free and halogen free package
- Compliance with EU REACH

### Description

The ALS-PDIC17-77C/TR8 is consisting of a photodiode and a current amplification IC. EVERLIGHT ALS series product is a good effective solution to the power saving of display backlighting of mobile appliances, such as the mobile phones, NB and PDAs. Due to the high rejection ratio of infrared radiation, the spectral response of the ambient light sensor is close to that of human eyes.

### Applications

- Detection of ambient light to control display backlighting
  - Mobile devices – mobile phones, PDAs
  - Computing device – TFT LCD monitor for Notebook computer
  - Consumer device – TFT LCD TV, plasma TV, video camera, digital camera, toys
- Automatic residential and commercial management
- Automatic contrast enhancement for electronic signboard
- Ambient light monitoring device for daylight and artificial light
  - Street light, CCD/CCTV

Package Dimensions

Top View

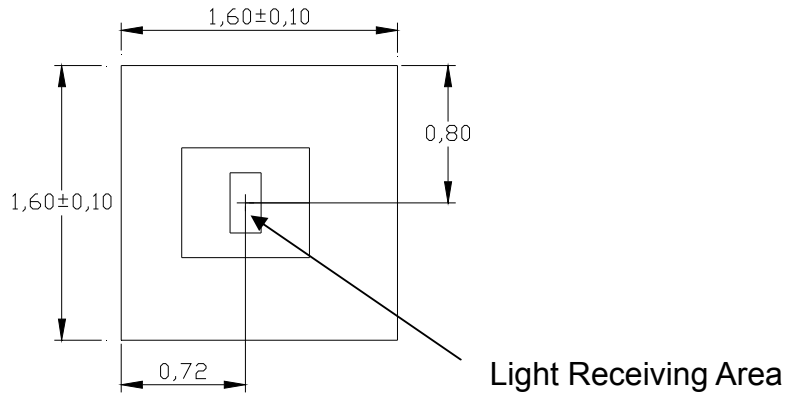

Side View

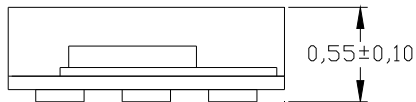

Bottom View

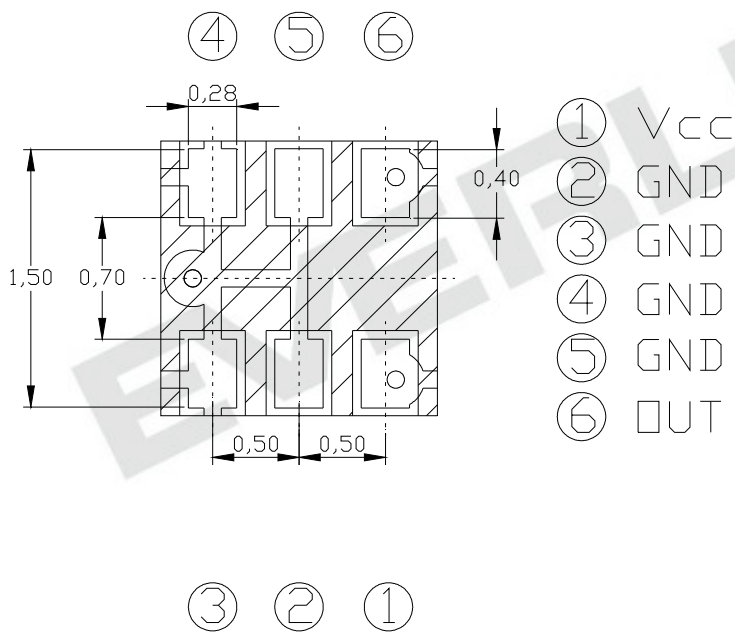

Recommended Soldering Pattern

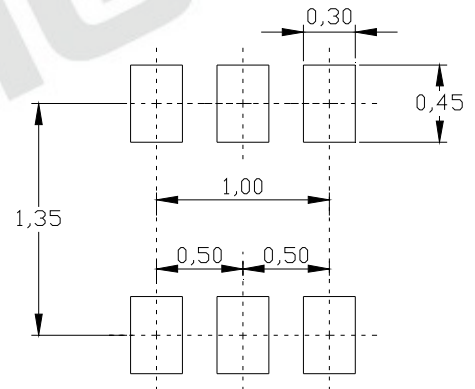

Unit : mm  
Tolerances : ±0.1mm

### Absolute Maximum Ratings

Parameter	Symbol	Rating	Unit
Supply Voltage	V <sub>CC</sub>	-0.5~6.0	V
Output Voltage	V <sub>O</sub>	0 ~ V <sub>CC</sub> -0.8	V
Output Photo Current	I <sub>PH</sub>	0 ~ 5	mA
Operating Temperature Range	T <sub>opr</sub>	-40 ~ +85	°C
Storage Temperature Range	T <sub>stg</sub>	-40 ~ +100	°C
Soldering Temperature Range [Note1]	T <sub>sol</sub>	260	°C

**Note1:** For detail reflow time and the recommended temperature profile, please refer to page 8.

### Recommended Operating Conditions

Parameter	Symbol	Min.	Max.	Unit
Operating Temperature	T <sub>opr</sub>	-40	+85	°C
Supply Voltage	V <sub>CC</sub>	1.8	5.5	V

Electrical and Optical Characteristics ( $T_a=25^\circ\text{C}$ )

Parameter	Symbol	Min.	Typ.	Max.	Unit	Test Condition	
Supply Current	$I_{CC}$	--	480	950	$\mu\text{A}$	$V_{CC} = 3\text{V}$ , $E_v = 1000\text{Lux}$ $R_L = 1\text{k}\Omega$ [Note2]	
Dark Current	$I_D$	--	--	100	nA	$V_{CC}=3\text{V}$ , $E_v= 0\text{Lux}$	
Light Current	$I_{PH1}$	2.7	4	5.4	$\mu\text{A}$	$V_{CC}=3\text{V}$ ; $E_v= 10\text{Lux}$ [Note1]	
	$I_{PH2}$	27	40	54	$\mu\text{A}$	$V_{CC}=3\text{V}$ ; $E_v= 100\text{Lux}$ [Note1]	
	$I_{PH3}$	--	48	92	$\mu\text{A}$	$V_{CC}=3\text{V}$ ; $E_v= 100\text{Lux}$ [Note2]	
	$I_{PH4}$	--	400	540	$\mu\text{A}$	$V_{CC}=3\text{V}$ ; $E_v=1000\text{Lux}$ [Note1]	
Photocurrent Ratio	$I_{PH3} / I_{PH2}$	--	1.2	1.7	--	--	
Saturation Output Voltage	$V_o$	2.20	2.35	--	V	$V_{CC}=3\text{V}$ ; $E_v= 100\text{Lx}$ , $R_L=150\text{k}\Omega$ [Fig.3]	
Peak Sensitivity Wavelength	$\lambda_p$	--	550	--	nm	--	
Switching Time	Rise Time	$t_r$	--	11	1000	$\mu\text{s}$	$V_{CC}=3\text{V}$ , $R_L=5\text{k}\Omega$ $E_v = 1000 \text{ Lux}$ [Fig.4]
	Fall Time	$t_f$	--	400	2000	$\mu\text{s}$	
	Delay Time	$t_d$	--	250	--	$\mu\text{s}$	
	Storage Time	$t_s$	--	35	--	$\mu\text{s}$	

Note:

1. White Fluorescent light (Color Temperature = 6500K) is used as light source. However, White LED is substituted in mass production.
2. Illuminance by CIE standard illuminant-A / 2856K, incandescent lamp.

Fig.1 Block Diagram

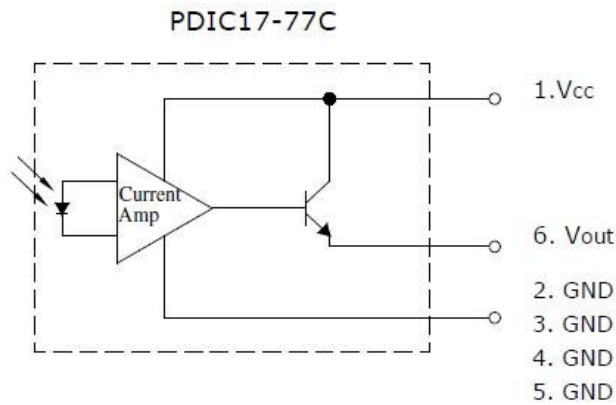

Fig.2 Measurement Method of Light Current

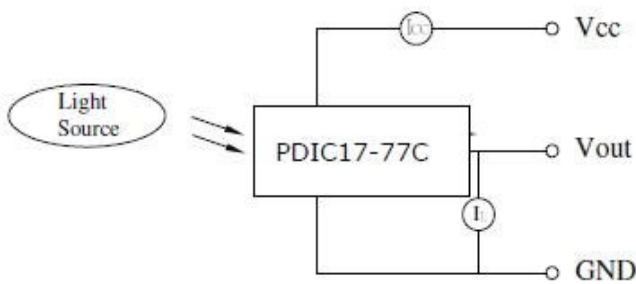

Fig.3 Measurement Method of Saturation Output Voltage

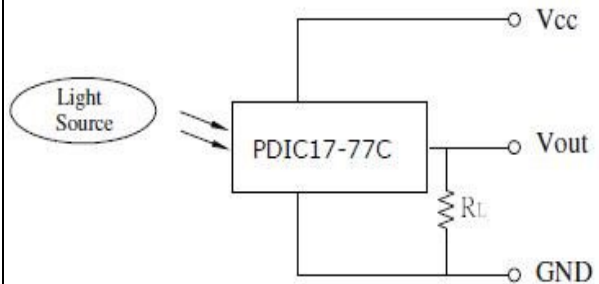
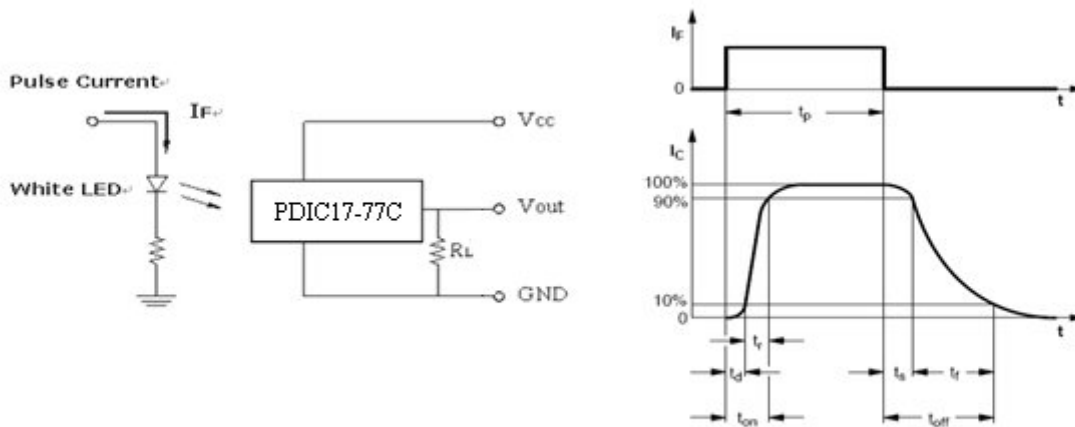

Fig.4 Switching Time Measurement Method



Typical Electrical and Optical Characteristics Curves

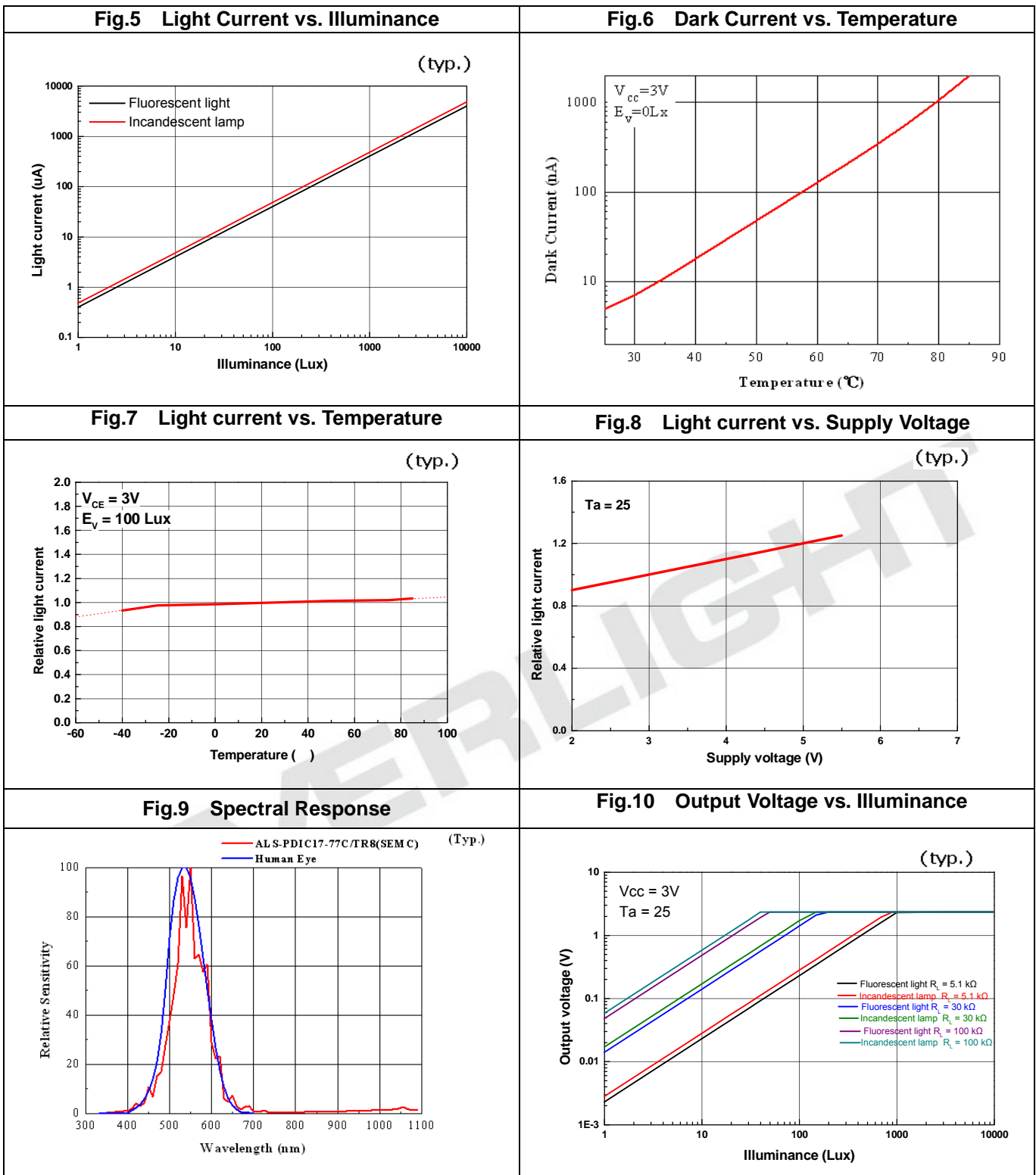

Fig.11 Consumption current vs. Illuminance (typ.)

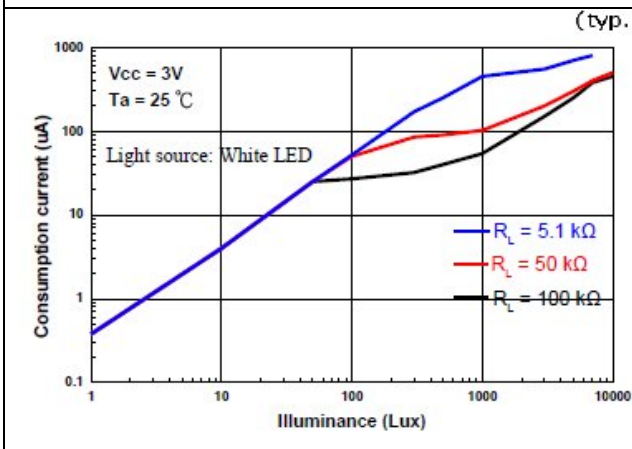
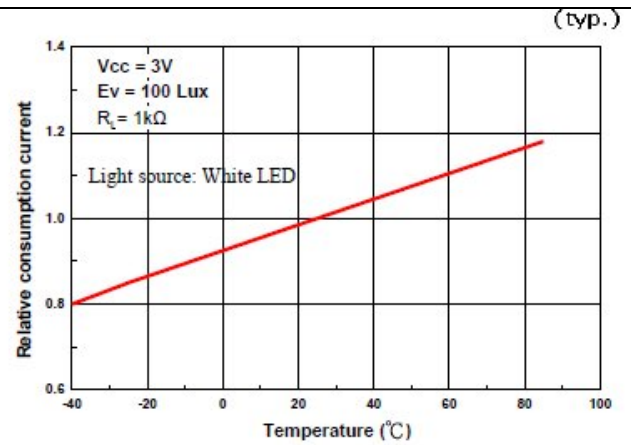
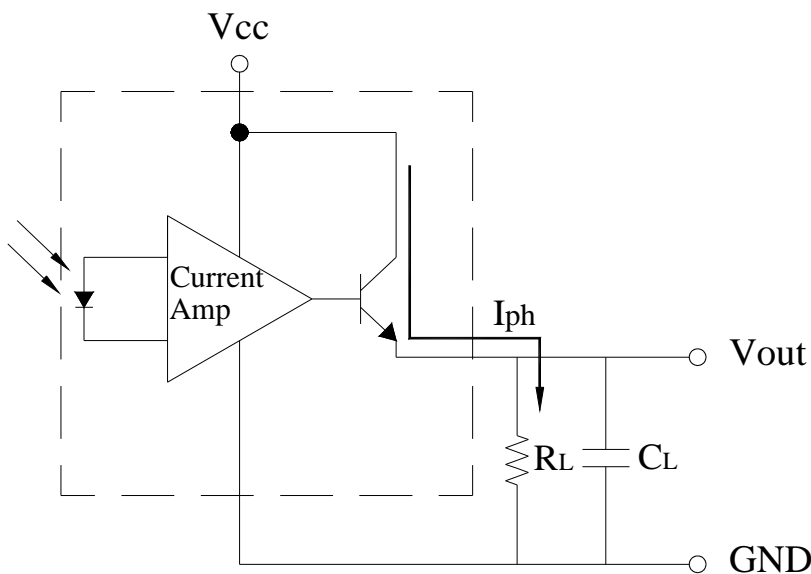

Fig.12 Relative consumption current vs. Temperature (typ.)



### Converting Photocurrent to Voltage



Note:

1. The output voltage ( $V_{out}$ ) is the product of photocurrent ( $I_{PH}$ ) and loading resistor ( $R_L$ )
2. A right loading resistor shall be chosen to meet the requirement of maximum ambient light, and output saturation voltage:

$$V_{out(max.)} = I_{out(max.)} \times R_L \quad V_{out(saturation)} = V_{CC} - 0.8V$$

3. To avoid 60Hz ripple from fluorescent lamps, we suggest that the time constant must be greater than 0.5 second:

$$R_L \times C_L > 0.5 \quad (\text{empirical data})$$

## Recommended method of storage

1. Do not open moisture proof bag before devices are ready to use.
2. Shelf life in sealed bag from the bag seal date:  
18 months at 10°C~30°C and < 90% RH.
3. After opening the package, the devices must be stored at 10°C~30°C and ≤ 60%RH, and used within 1 year (floor life).
4. If the moisture absorbent material (desiccant material) has faded or unopened bag has exceeded the shelf life or devices (out of bag) have exceeded the floor life, baking treatment is required.
5. If baking is required, refer to IPC/JEDEC J-STD-033 for bake procedure or recommend the following conditions:  
192 hours at 40°C +5/-0°C and < 5 % RH (reeled/tubed/loose units) or  
96 hours at 60°C ± 5°C and < 5 % RH (reeled/tubed/loose units) or  
24 hours at 125°C ± 5°C, not suitable for reel or tubes.

## Recommended Solder Profile

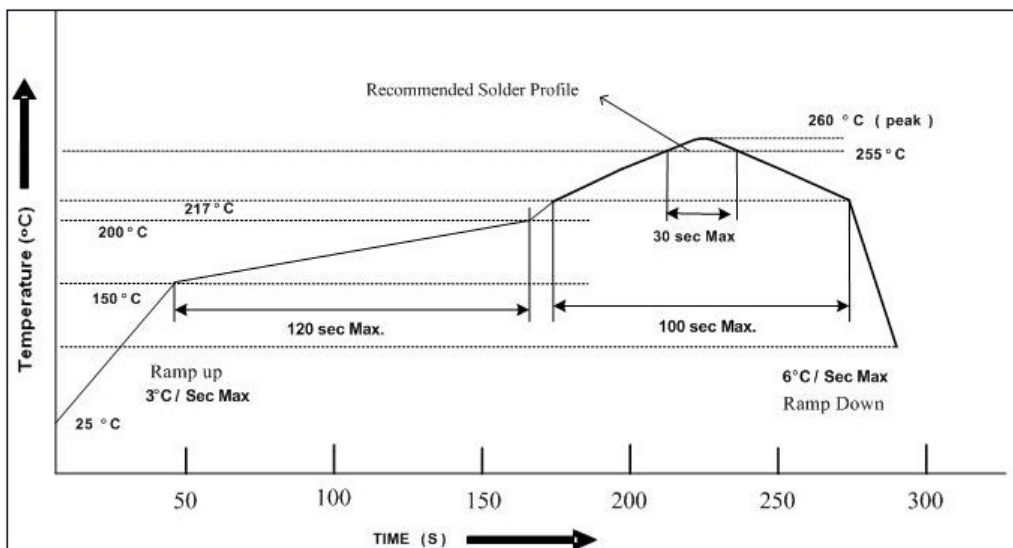

### Notice:

- (1) Reflow soldering should not be done more than two times.
- (2) When soldering, do not put stress on the devices during heating.
- (3) After soldering, do not warp the circuit board.



## Soldering Iron

Each terminal is to go to the tip of soldering iron temperature less than 350 for 3 seconds within once in less than the soldering iron capacity 25W. Leave two seconds and more intervals, and do soldering of each terminal. Be careful because the damage of the product is often started at the time of the hand solder.

## Repairing

Repair should not be done after the device have been soldered. When repairing is unavoidable, a double-head soldering iron should be used (as below figure). It should be confirmed beforehand whether the characteristics of the device will or will not be damaged by repairing.

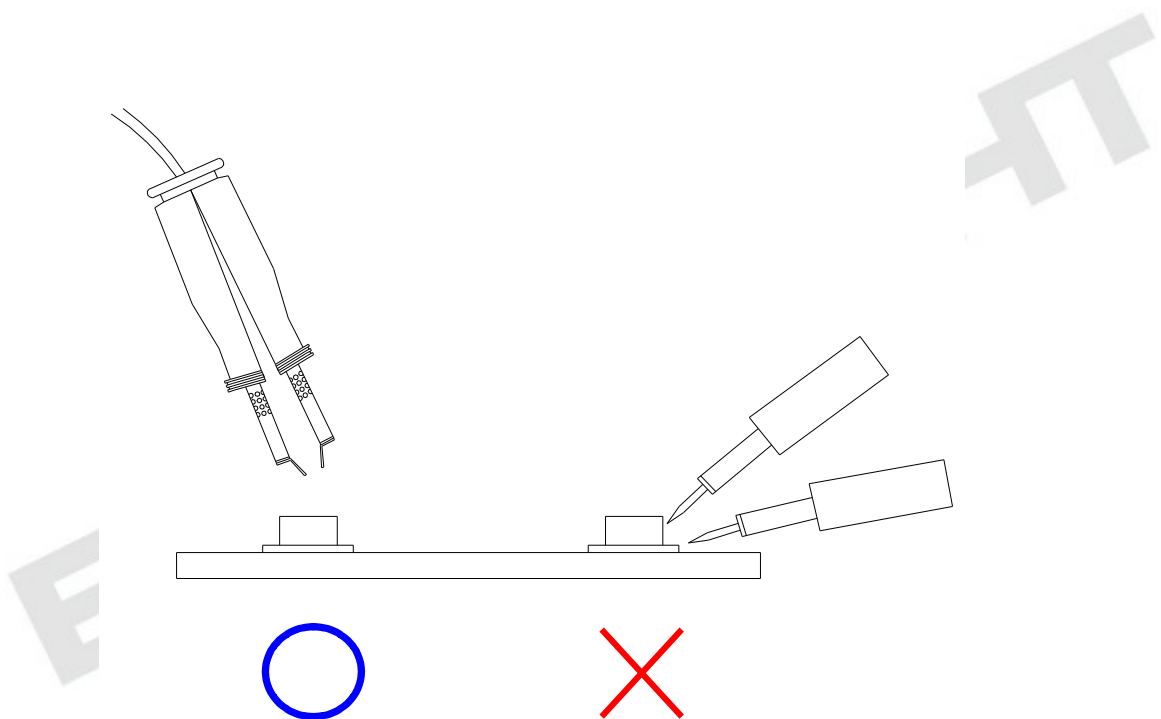

**Packing Quantity Specification**

4000 PCS/ 1 Reel

**Label Format**

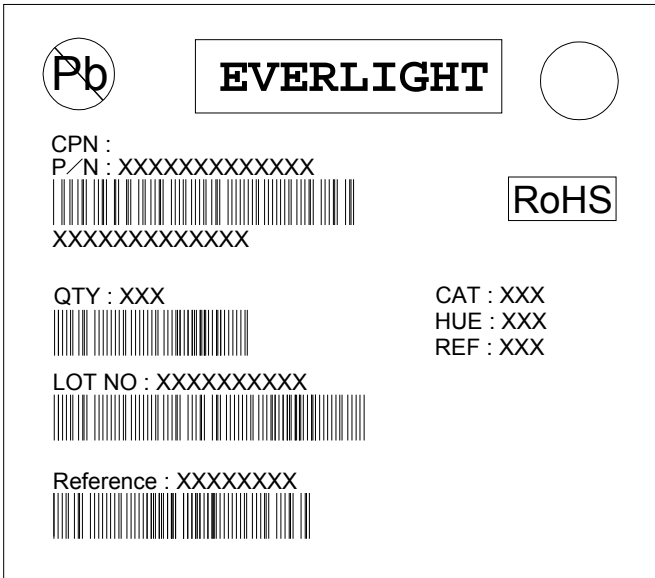

CPN: Customer's Production Number  
P/N : Production Number  
QTY: Packing Quantity  
CAT: Ranks  
HUE: Peak Wavelength  
REF: Reference  
LOT No: Lot Number  
MADE IN TAIWAN: Production Place

**Reel Dimensions**

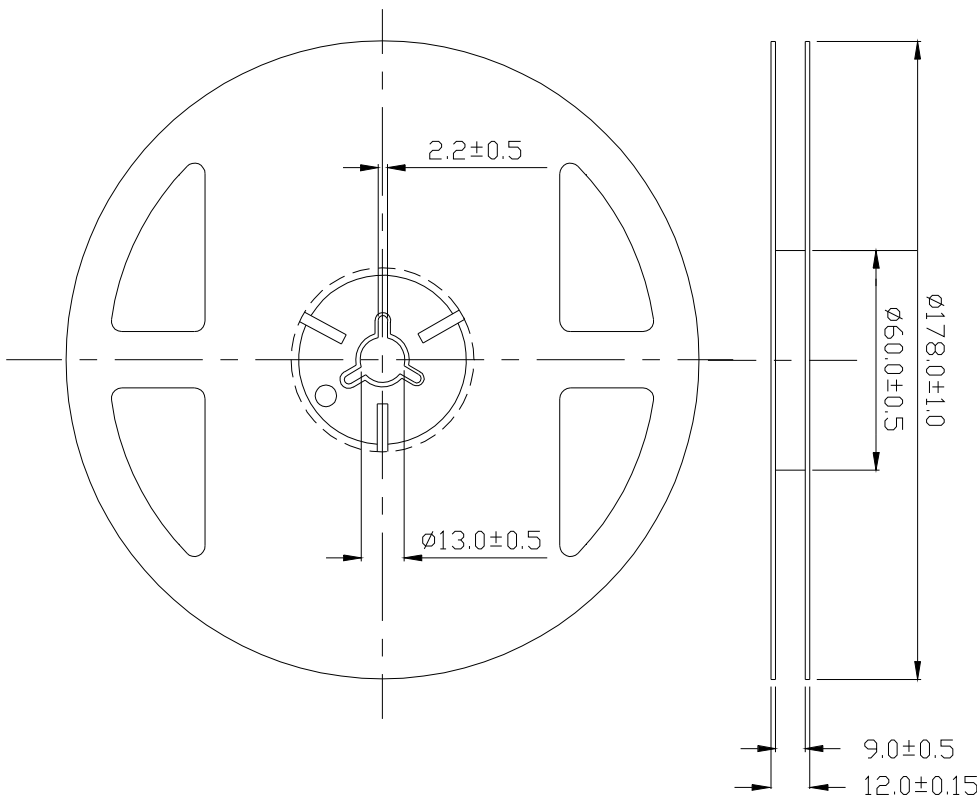

Unit: mm  
Tolerance:  $\pm 0.1$ mm

Tape Dimensions

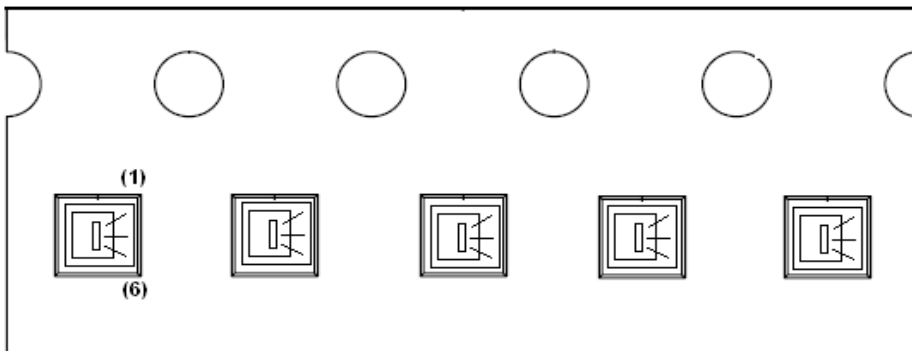
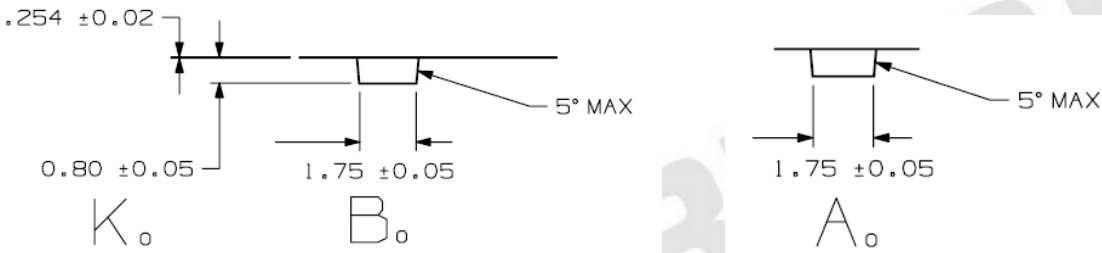
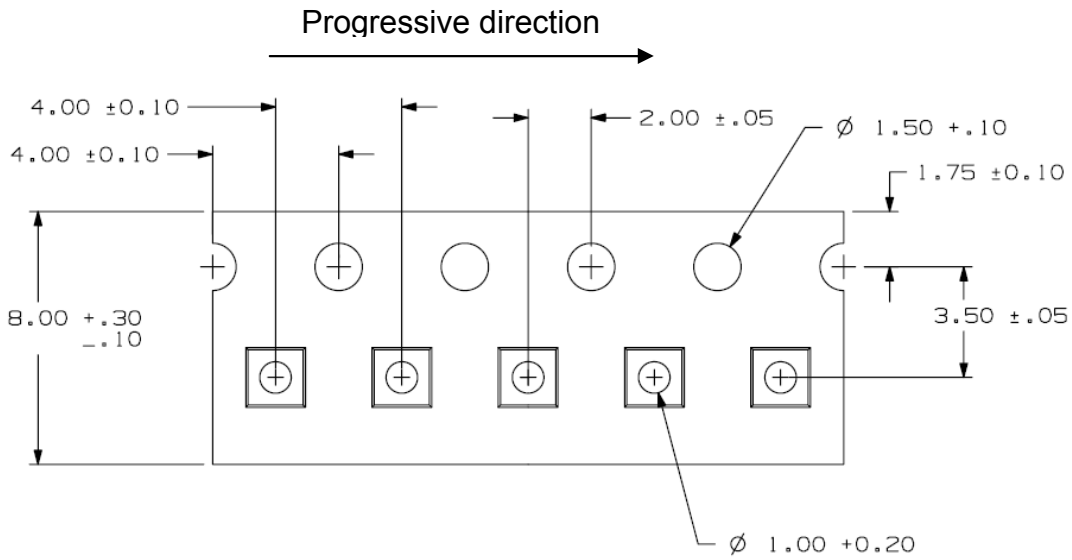

Unit: mm  
Tolerance: ±0.1mm

Note:

1. Above specification may be changed without notice. EVERLIGHT will reserve authority on material change for above specification.
2. When using this product, please observe the absolute maximum ratings and the instructions for using outlined in these specification sheets. EVERLIGHT assumes no responsibility for any damage resulting from use of the product which does not comply with the absolute maximum ratings and the instructions included in these specification sheets.
3. These specification sheets include materials protected under copyright of EVERLIGHT corporation. Please don't reproduce or cause anyone to reproduce them without EVERLIGHT's consent.

EVERLIGHT