

PNPN Epitaxial Planar SCR

BCR1002N3

Descriptions

The BCR1002N3 is designed for high volume consumer applications such as temperature, light, and speed control; process and remote control, and warning systems where reliability of operation is important.

Features

- Practical level triggering and holding characteristics
- On state current rating of 0.2A_{RMS}
- Sensitive gate allows triggering by microcontrollers and other logic circuits
- Pb-free package

Symbol

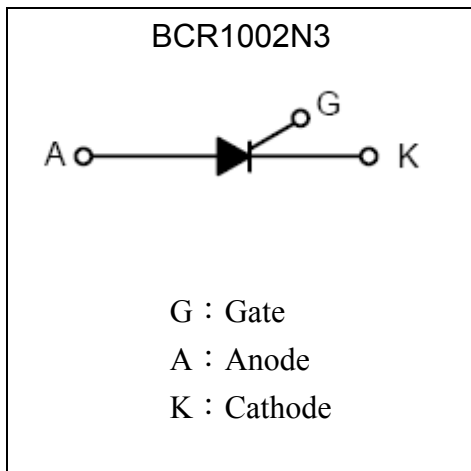

Outline

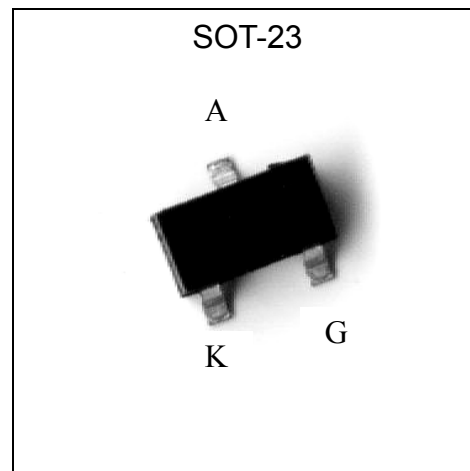

Ordering Information

Device	Package	Shipping
BCR1002N3-0-T1-G	SOT-23 (Pb-free lead plating and halogen-free package)	3000 pcs / Tape & Reel

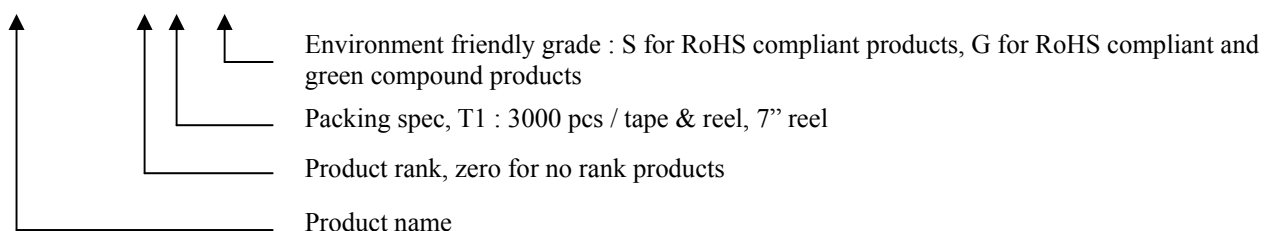

**Absolute Maximum Ratings (T_J=25°C)**

Parameter	Symbol	Limits	Unit
Peak Repetitive Off-State Voltage @T _J =-40°C to 125°C, R _{GK} =1KΩ	V _{DRM}	140	V
On-State Current @T _C =80°C	I _{T(RMS)}	350	mA
Average On-State Current @ T _C =80°C	I _{T(AV)}	220	mA
Reverse Peak Gate Voltage @T _A =25°C, Pulse Width≤1μs	V _{GRM}	8	V
Forward Peak Gate Current @T _A =25°C, Pulse Width≤1μs	I _{GM}	500	mA
Forward Average Gate Power @ T _A =25°C, t=8.3ms	P _{G(AV)}	100	mW
Thermal Resistance, Junction to Ambient	R _{θJA}	556	°C/W
Thermal Resistance, Junction to Case	R _{θJC}	208	°C/W
Junction Temperature	T _J	-40~+125	°C
Storage Temperature	T _{stg}	-40~+150	°C

Note : Stress exceeding maximum ratings may damage the device. Maximum ratings are stress ratings only. Functional operation above the recommended operating conditions is not implied. Extended exposure to stresses above the recommended operating conditions may affect device reliability.

V_{DRM} can be applied on a continuous basis. Ratings apply for zero or negative gate voltage; however, positive gate voltage shall not be applied concurrent with negative potential on the anode. Blocking voltage shall not be tested with a constant current source such that the voltage ratings of the device are exceeded.

Characteristics (T_a=25°C)

Symbol	Min.	Typ.	Max.	Unit	Test Conditions
I _{DRM}	-	-	100	μA	V _D =140V, R _{GK} =1KΩ, T _C =125°C
I _{DRM}	-	-	10	μA	V _D =140V, R _{GK} =1KΩ, T _C =25°C
*V _{TM}	-	-	1.5	V	I _{TM} =200mA
I _{GT}	-	-	100	μA	V _D =7V, R _L =100Ω
I _H	-	-	5	mA	V _D =7V, R _{GK} =1KΩ
I _L	-	-	6	mA	V _D =7V, I _G =200μA
V _{GT}	-	-	0.8	V	V _D =7V, R _L =100Ω
dV/dt	25	-	-	V/μs	V _D =35V, R _{GK} =1KΩ
dI/dt	30	-	-	A/μs	I _G =10mA, dI _G /dt=100mA/μs, P _w =10μs

*Pulse Test: Pulse Width ≤300μs, Duty Cycle≤2%

Recommended Soldering Footprint

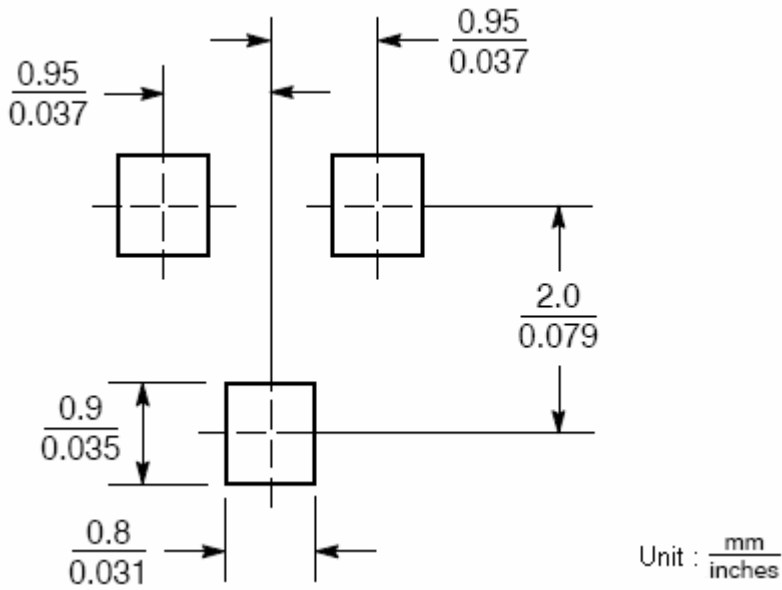

Typical Characteristics

Gate Trigger Current vs Junction Temperature

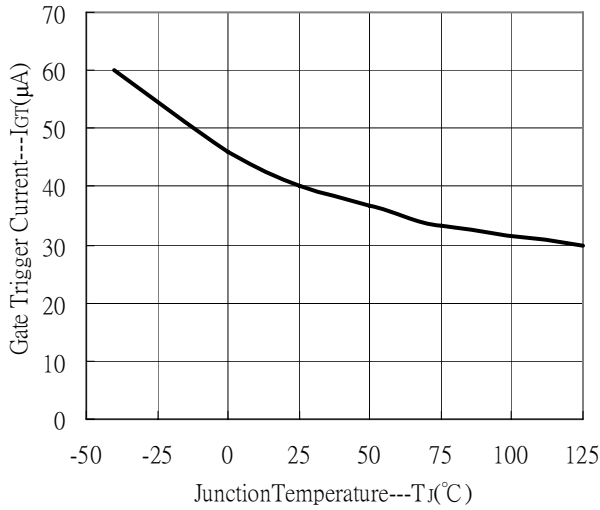

Gate Trigger Voltage vs Junction Temperature

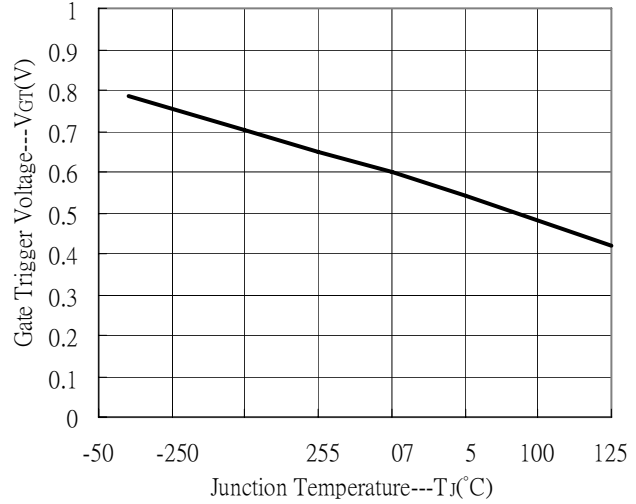

Holding Current vs Junction Temperature

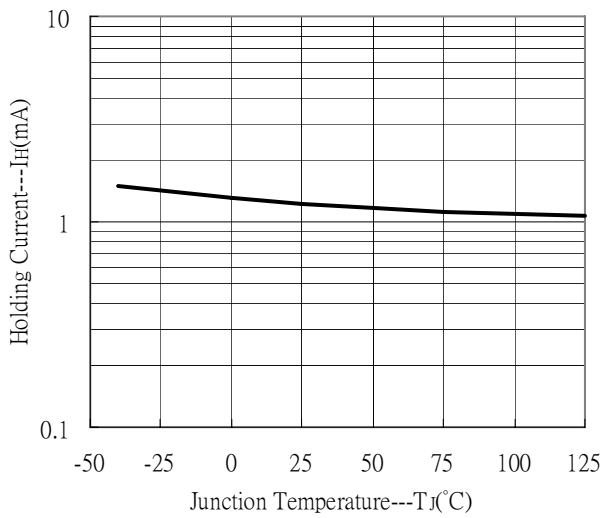

Latching Current vs Junction Temperature

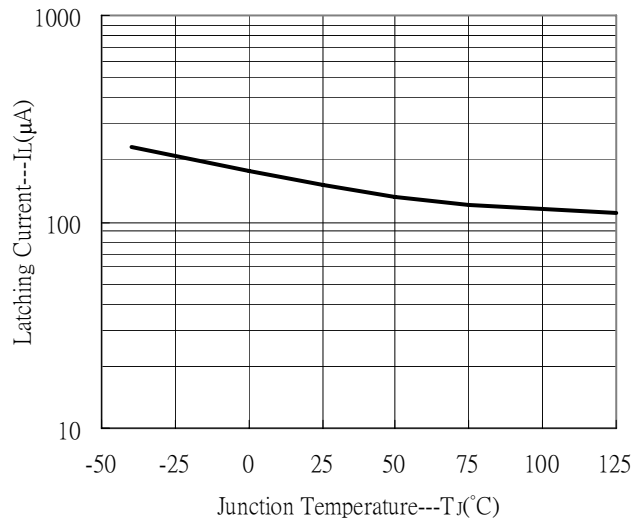

On-state Characteristics

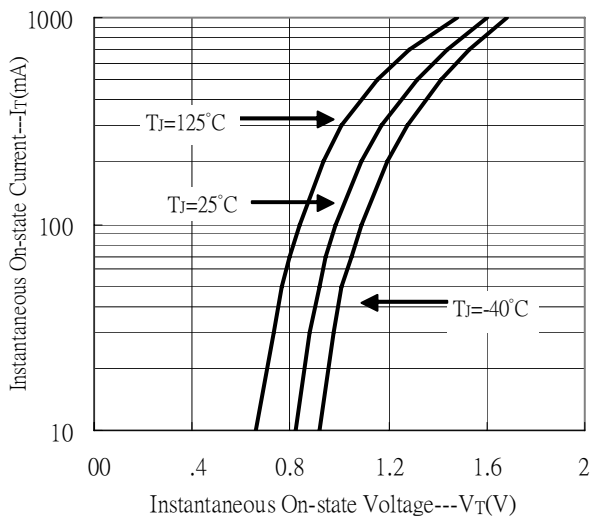

Reel Dimension

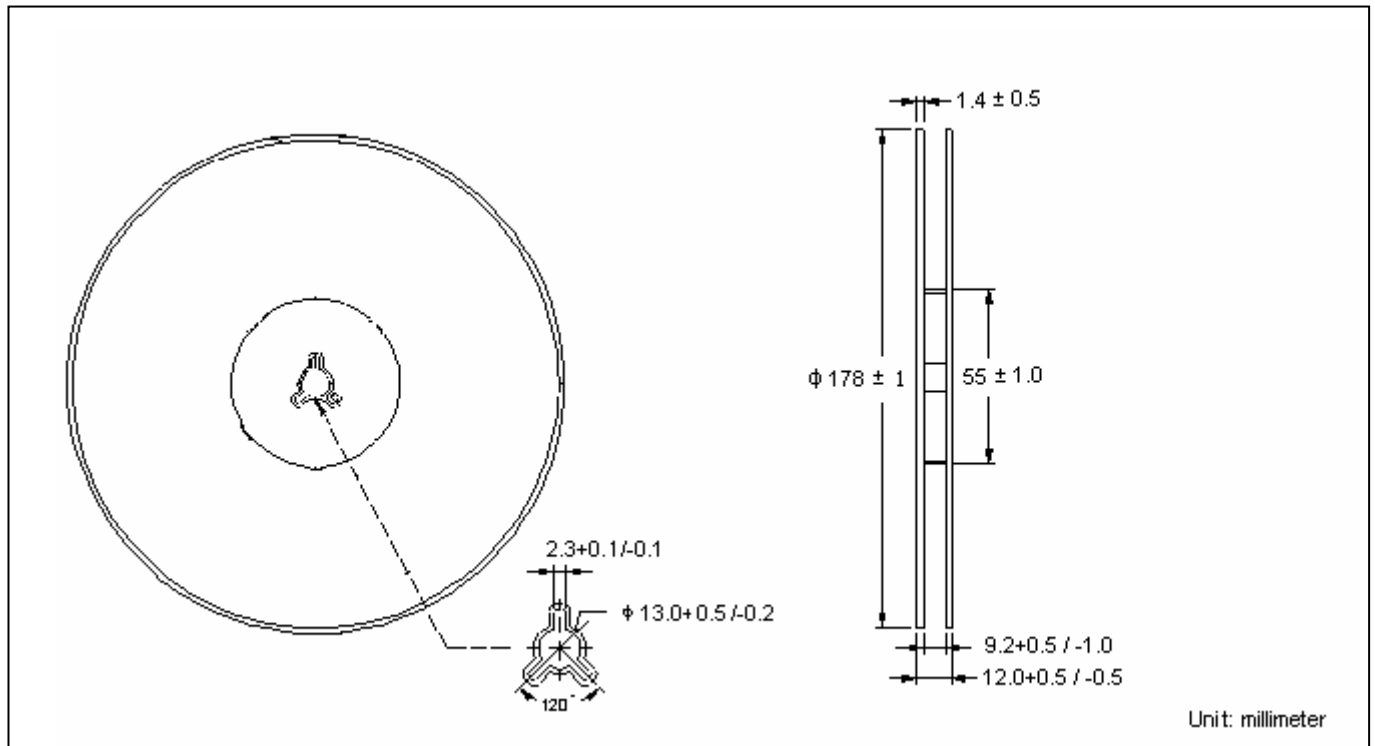

Carrier Tape Dimension

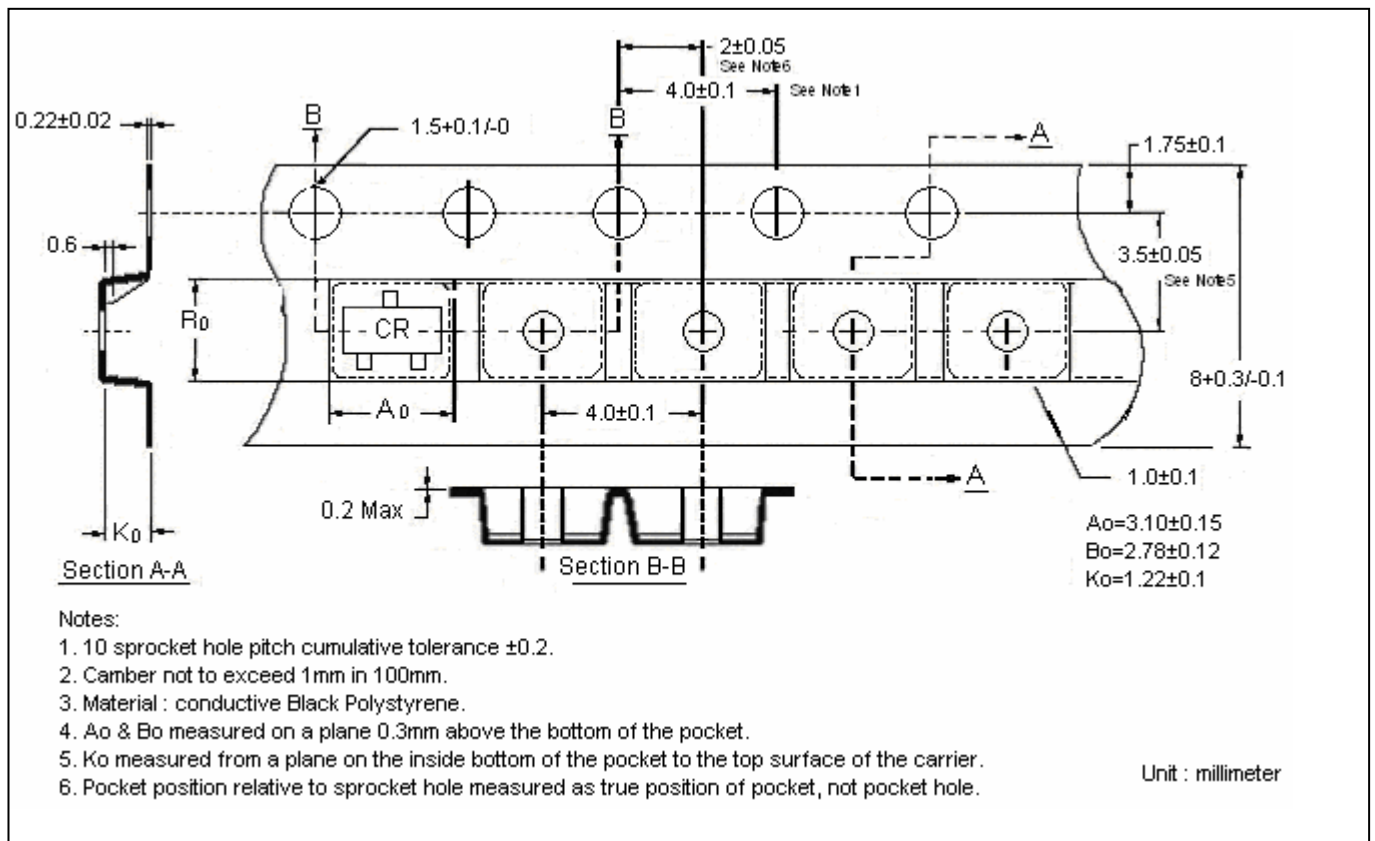

Recommended wave soldering condition

Product	Peak Temperature	Soldering Time
Pb-free devices	260 +0/-5 °C	5 +1/-1 seconds

Recommended temperature profile for IR reflow

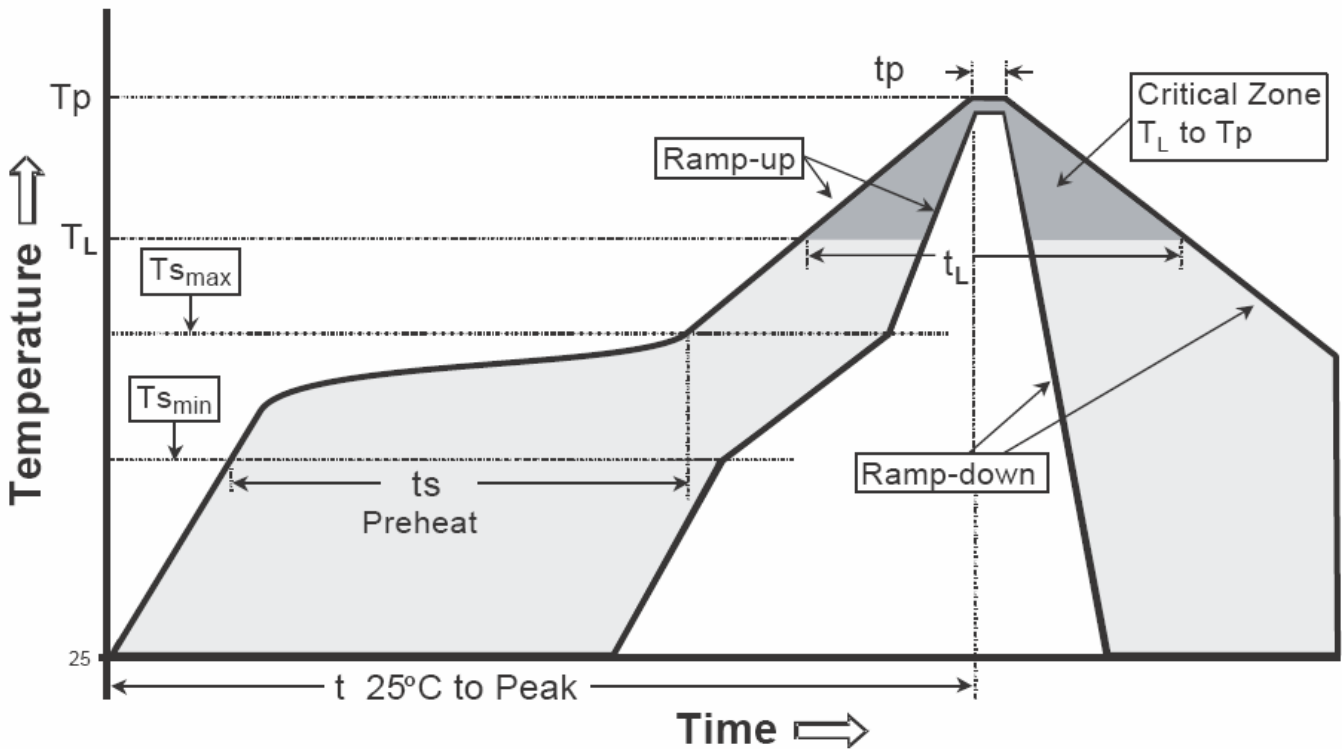

Profile feature	Sn-Pb eutectic Assembly	Pb-free Assembly
Average ramp-up rate (T _{smax} to T _p)	3°C/second max.	3°C/second max.
Preheat		
-Temperature Min(T _{s min})	100°C	150°C
-Temperature Max(T _{s max})	150°C	200°C
-Time(t _{s min} to t _{s max})	60-120 seconds	60-180 seconds
Time maintained above:		
-Temperature (T _L)	183°C	217°C
- Time (t _L)	60-150 seconds	60-150 seconds
Peak Temperature(T _P)	240 +0/-5 °C	260 +0/-5 °C
Time within 5°C of actual peak temperature(tp)	10-30 seconds	20-40 seconds
Ramp down rate	6°C/second max.	6°C/second max.
Time 25 °C to peak temperature	6 minutes max.	8 minutes max.

Note : All temperatures refer to topside of the package, measured on the package body surface.

SOT-23 Dimension

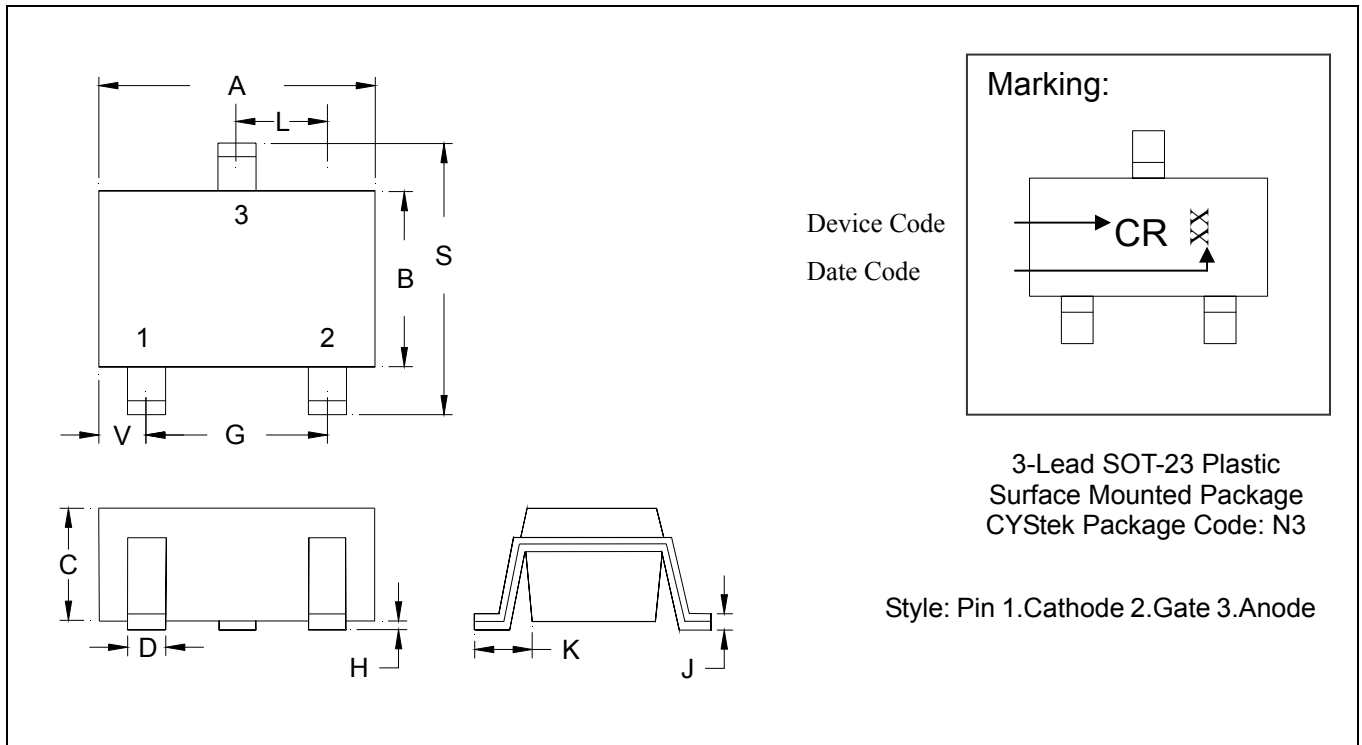

*: Typical

DIM	Inches		Millimeters		DIM	Inches		Millimeters	
	Min.	Max.	Min.	Max.		Min.	Max.	Min.	Max.
A	0.1102	0.1204	2.80	3.04	J	0.0034	0.0070	0.085	0.177
B	0.0472	0.0630	1.20	1.60	K	0.0128	0.0266	0.32	0.67
C	0.0335	0.0512	0.89	1.30	L	0.0335	0.0453	0.85	1.15
D	0.0118	0.0197	0.30	0.50	S	0.0830	0.1083	2.10	2.75
G	0.0669	0.0910	1.70	2.30	V	0.0098	0.0256	0.25	0.65
H	0.0005	0.0040	0.013	0.10					

Notes: 1.Controlling dimension: millimeters.
 2.Maximum lead thickness includes lead finish thickness, and minimum lead thickness is the minimum thickness of base material.
 3.If there is any question with packing specification or packing method, please contact your local CYStek sales office.

Material:

- Lead: Pure tin plated.
- Mold Compound: Epoxy resin family, flammability solid burning class: UL94V-0.

Important Notice:

- All rights are reserved. Reproduction in whole or in part is prohibited without the prior written approval of CYStek.
- CYStek reserves the right to make changes to its products without notice.
- CYStek **semiconductor products are not warranted to be suitable for use in Life-Support Applications, or systems.**
- CYStek assumes no liability for any consequence of customer product design, infringement of patents, or application assistance.