

IN91350A

13 Memory Tone/Pulse Dialer with Handfree and Hold Function

The IN91350A is a silicon CMOS IC that provide necessary signal for either Pulse or Tone dialing. It features Handfree dialing, Hold, and 13 by 16 digits automatic dialing memory.

- DTMF/PULSE switchable dialer
- 32 digits for Redial memory
- Three by 16 digits for one touch direct repertory
- Ten by 16 digits for two touch indirect repertory
- Mix dialing is allowable, and the dialing length is unlimited
- Pulse to Tone (*T) keypad for Long Distance Call operation
- Easy operation with Redial, Flash, Pause and */T keypads
- Pause, P- - >T (Pulse to Tone) can be stored as a digit in memory
- Flash time 600 mS
- 4 x 5 keyboard can be used
- Power on reset on chip
- Use 3.579545 MHz crystal or ceramic resonator
- Dial Pulse Rate: 10 pps

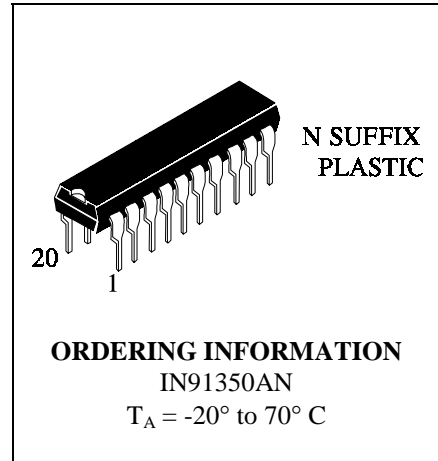

PIN ASSIGNMENT

$\overline{C1}$	1 ●	20	$\overline{R4}$
$\overline{C2}$	2	19	$\overline{R3}$
$\overline{C3}$	3	18	$\overline{R2}$
$\overline{C4}$	4	17	$\overline{R1}$
H/P MUTE	5	16	V _{CC}
GND	6	15	MODE
XT	7	14	DTMF
\overline{XT}	8	13	$\overline{DP/C5}$
T/P MUTE	9	12	\overline{HKS}
$\overline{HF1}$	10	11	HFO

LOGIC DIAGRAM

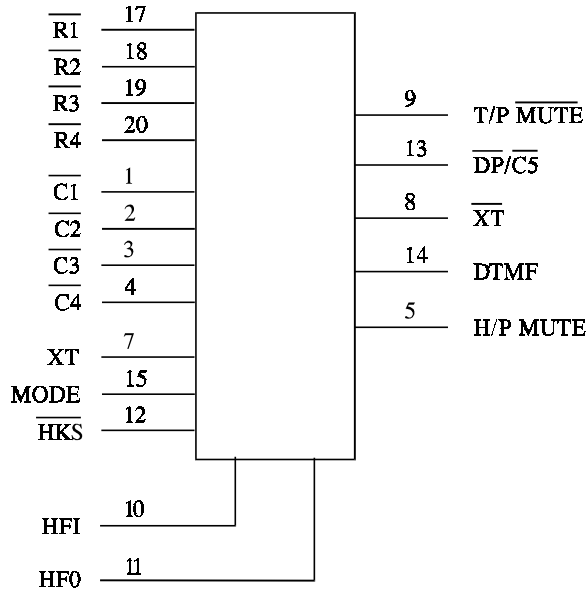

PIN 6 = GND
 PIN 16 = V_{CC}

Keyboard Assignments

1	2	3	ST	M1	— R1
4	5	6	F	M2	— R2
7	8	9	A	M3	— R3
*/T	0	#	R/P	H	— R4
C1	C2	C3	C4	C5	

Notes:

- M1 ~ M3 - One touch memory. The dialing number can be stored in M1 ~ M3 location by STORE key.
- ST - Store function key.
- H - Hold function key.
- F - Flash key.
Flash key can not be stored in memory.
- */T - In the Pulse mode this key works as Pulse - ->Tone key, and it works as * key in the tone mode.
*/T key can be stored as a digit in Pulse or Tone mode.
- R/P - Redial and Pause function key.
The Redial function can be executed only in first key-in after OFF HOOK, otherwise will be operated as Pause function.
- A - Indirect repertory dialing function key.

Pin Description

Pin No.	Designation	Description																																								
1 - 4 17 - 20	Column-Row Inputs	The Keyboard input may be used with the standard 4 x 5 keyboard. A valid key entry is defined by a single row being connected to a single column.																																								
5	H/P MUTE	The H/P MUTE is a conventional inverter output. In pulse dialing, flash and hold period, the output will be at active high, otherwise, it will keep at low state.																																								
6	GND	Power supply pins.																																								
16	V _{CC}	This device is designed to operate from 2.0 V to 5.5 V.																																								
7	XT	A built in inverter provides oscillation with an inexpensive 3.579545 MHz crystal or ceramic resonator.																																								
8	\overline{XT}	The oscillator output pin.																																								
9	T/P MUTE	The T/P MUTE is a conventional CMOS N-channel open drain output. The output transistor is switched on during Pulse and Tone mode dialing sequence and Flash break. Otherwise, it is switched off.																																								
10, 11	\overline{HFI} , HFO	<p>Handfree control pins. When \overline{HFI} input pin has a low pulse, the handfree control state is toggled on. Status of the handfree control state is listed in the following table:</p> <table border="1"> <thead> <tr> <th colspan="2">CURRENT STATE</th> <th colspan="3">NEXT STATE</th> </tr> <tr> <th>Hook SW.</th> <th>HFO</th> <th>Input</th> <th>HFO</th> <th>Dialing?</th> </tr> </thead> <tbody> <tr> <td>X</td> <td>Low</td> <td>$\overline{HFI} \downarrow$</td> <td>High</td> <td>Yes</td> </tr> <tr> <td>On Hook</td> <td>High</td> <td>$\overline{HFI} \downarrow$</td> <td>Low</td> <td>No</td> </tr> <tr> <td>Off Hook</td> <td>High</td> <td>$\overline{HFI} \downarrow$</td> <td>Low</td> <td>Yes</td> </tr> <tr> <td>On Hook</td> <td>X</td> <td>Off Hook</td> <td>Low</td> <td>Yes</td> </tr> <tr> <td>Off Hook</td> <td>Low</td> <td>On Hook</td> <td>Low</td> <td>No</td> </tr> <tr> <td>Off Hook</td> <td>High</td> <td>On Hook</td> <td>High</td> <td>Yes</td> </tr> </tbody> </table> <p>\overline{HFI} pin is pulled to V_{CC} by internal resistor. X = don't care.</p>	CURRENT STATE		NEXT STATE			Hook SW.	HFO	Input	HFO	Dialing?	X	Low	$\overline{HFI} \downarrow$	High	Yes	On Hook	High	$\overline{HFI} \downarrow$	Low	No	Off Hook	High	$\overline{HFI} \downarrow$	Low	Yes	On Hook	X	Off Hook	Low	Yes	Off Hook	Low	On Hook	Low	No	Off Hook	High	On Hook	High	Yes
CURRENT STATE		NEXT STATE																																								
Hook SW.	HFO	Input	HFO	Dialing?																																						
X	Low	$\overline{HFI} \downarrow$	High	Yes																																						
On Hook	High	$\overline{HFI} \downarrow$	Low	No																																						
Off Hook	High	$\overline{HFI} \downarrow$	Low	Yes																																						
On Hook	X	Off Hook	Low	Yes																																						
Off Hook	Low	On Hook	Low	No																																						
Off Hook	High	On Hook	High	Yes																																						
12	\overline{HKS}	This pin is the hook switch input. \overline{HKS} = H, ON HOOK state, chip in sleeping mode, no operation. \overline{HKS} = L, OFF HOOK state, enable chip on normal operation. This pin must combine to \overline{HFI} , HFO to perform the above function. Please refer to \overline{HFI} , HFO pin. \overline{HKS} pin is pulled to V _{CC} by internal resistor.																																								
13	$\overline{DP/C5}$	Open drain dialing pulse output. Flash key will cause DP active either in Tone mode or Pulse mode.																																								
14	DTMF	In pulse mode, it always keeps at low state. In tone mode, it will output a dual or single tone.																																								
15	MODE	Pull mode pin to GND; the dialer is in Tone mode. Pull mode pin to V _{CC} ; the dialer is in Pulse mode - 10 pps, M/B=2/3. Pull mode pin to floating; the dialer is in Pulse mode - 10 pps, M/B=1/2.																																								

Operation Procedures:

Symbol Definitions

In the description below, signals are defined in terms of the key or switch which is activated.

- Off Hook means the phone was taken off the hook.
- On Hook means that the receiver is on the hook.
- D1 or L1 stands for the first digit dialed in a string of digits.
- Dn or Ln stands for the last digit dialed in a string of digits.
- Dn+1 stands for the beginning of a new string of digits.
- Dn+m stands for the last digit in a new string of digits.
- $\overline{\downarrow}$ Input Level from High to Low.

Mn=M1~M3; Ln=0~9; Dn=0~9,*,#,Pause.

1. Normal Dialing

Off Hook (or On Hook & $\overline{\text{HFI}} \overline{\downarrow}$),
D1 , D2 , ..., Dn

- 1.D1, D2, ... , Dn will be dialed out.
- 2.Dialing length is unlimited, but the Redial is inhibited if it oversteps 32 digits.

2. Redialing

Off Hook , D1 , D2 , .. , Dn , BUSY,
 Come On Hook , Off Hook (or On Hook & $\overline{\text{HFI}} \overline{\downarrow}$), R/P (or On Hook & $\overline{\text{HFI}} \overline{\downarrow}$), D1 , D2 , ..., Dn , BUSY,
 $\overline{\text{HFI}} \overline{\downarrow}$,Come $\overline{\text{HFI}} \overline{\downarrow}$, R/P

The R/P key can execute Redial function only in first key-in after Off Hook, otherwise it will be Pause function.

3. Number store

1. Off Hook (or On Hook & $\overline{\text{HFI}} \overline{\downarrow}$),
D1 , D2 , ..., Dn , ST , ST , Mn or Ln
On Hook (or On Hook & $\overline{\text{HFI}} \overline{\downarrow}$)

- a.The dialing of D1, D2, ... , Dn must have finished, then ST key may be pressed.
- b.D1, D2, ... , Dn will be stored in Mn or Ln memory location and they will be dialed out.

2. Off Hook (or On Hook & $\overline{\text{HFI}} \overline{\downarrow}$),
ST , D1 , D2 , ..., Dn , ST , Mn or Ln
On Hook (or On Hook & $\overline{\text{HFI}} \overline{\downarrow}$)

- a.D1, D2, ... , Dn will be stored in Mn or Ln memory location but they will not be dialed out.
- b.R/P and */T keys can be stored as a digit in memory. In store mode, R/P in the pause function key.
- c.The store mode can be release after the store function is executed or the present state of hook switch is changed.

4. Repertory Dialing

1. Off Hook (or On Hook & $\overline{\text{HFI}} \overline{\downarrow}$) Mn
 2. Off Hook (or On Hook & $\overline{\text{HFI}} \overline{\downarrow}$) A ,
Ln

5. Access Pause

Off Hook (or On Hook & $\overline{\text{HFI}} \overline{\downarrow}$),
D1 , D2 , R/P , D3 , ..., Dn

- 1.The Pause function can be stored in memory.
- 2.The Pause function is executed in normal dialing or Redialing or memory dialing.

6. Pulse to Tone (*T)

Off Hook (or On Hook & $\overline{\text{HFI}} \overline{\downarrow}$),
D1 , D2 , ..., Dn , */T ,
Dn+1 , Dn+2 , ..., Dn+m

- 1.If the mode switch is set in Pulse mode, then the output signal will be:
 D1, D2, ... , Dn, Pause
 (Pulse)
 Dn+1, Dn+2, ... , Dn+m
 (Tone)
- 2.If the mode switch is set in Tone mode, then the output signal will be:
 D1, D2, ... , Dn,
 (Tone)
 , * , Dn+1, Dn+2, ... , Dn+m
 (Tone) (Tone)
- 3.It can be reset to Pulse mode only in operation of On Hook, because it's still in Tone mode when the digits have been dialed out.

7. Flash

Off Hook (or On Hook & HFI ) F

1. Flash key can not be stored as a digit in memory and it has the first priority of the keyboard function.
2. The system will return to the initial state after the break time is finished.

8. Mix Dialing

Off Hook (or On Hook & HFI )

1. Normal dialing + Repertory dialing
+ Normal dialing

2. Repertory dialing + Normal dialing
+ Repertory dialing

3. Redialing + Normal dialing
+ Repertory dialing

- a. Redialing and Save dialing are valid just for first key in.
- b. The second sequence should not be operated until the first sequence is dialed out completely.

MAXIMUM RATINGS*

Symbol	Parameter	Value	Unit
V _{CC}	DC Supply Voltage (Referenced to GND)	-0.3 to +7.0	V
V _{IN}	DC Input Voltage (Referenced to GND)	-0.3 to V _{CC} +0.3	V
V _{OUT}	DC Output Voltage (Referenced to GND)	-0.3 to V _{CC} +0.3	V
P _D	Power Dissipation in Still Air, Plastic DIP**	500	mW
T _{stg}	Storage Temperature	-55 to +150	°C

* Maximum Ratings are those values beyond which damage to the device may occur. Functional operation should be restricted to the Recommended Operating Conditions.

** Duration: -10 mW/°C from 65°C to 70°C.

RECOMMENDED OPERATING CONDITIONS

Symbol	Parameter	Min	Max	Unit
V _{CC}	DC Supply Voltage (Referenced to GND)	2.0	5.5	V
V _{IN}	DC Input Voltage (Referenced to GND)	0	V _{CC}	V
V _{OUT}	DC Output Voltage (Referenced to GND)	0	V _{CC}	V
T _A	Operating Temperature	-20	+70	°C

This device contains protection circuitry to guard against damage due to high static voltages or electric fields. However, precautions must be taken to avoid applications of any voltage higher than maximum rated voltages to this high-impedance circuit. For proper operation, V_{IN} and V_{OUT} should be constrained to the range GND ≤ (V_{IN} or V_{OUT}) ≤ V_{CC}.

Unused inputs must always be tied to an appropriate logic voltage level (e.g., either GND or V_{CC}). Unused outputs must be left open.

DC ELECTRICAL CHARACTERISTICS(Voltages Referenced to GND, $V_{CC} = 2.5\text{ V}$,
 $T_A = 25^\circ\text{C}^*$, $F_{OSC} = 3.58\text{ MHz}$)

Symbol	Parameter	Test Conditions		Guaranteed Limits			Unit
				Min	Typ	Max	
I_{CCT}	Maximum Operating Current	Tone mode	All outputs unloaded	-		0.50	mA
I_{CCP}		Pulse mode		-		0.30	
I_{SB}	Maximum Standby Current	$\overline{HKS} = 0$ No load & No key entry		-		15	μA
I_{MR}	Maximum Memory Retention Current	$\overline{HKS} = H$ $V_{CC} = 1.0\text{ V}$		-		0.2	μA
V_{TO}	DTMF Output Voltage	Row group, $R_L = 5\text{ k}\Omega$		130		170	mVrms
T_{WIST}	Pre-emphasis	Col/Row, $V_{CC} = 2.0 \sim 5.5\text{ V}$		1		3	dB
T_{HD}	DTMF Distortion	$R_L = 5\text{ k}\Omega$, $V_{CC} = 2.0 \sim 5.5\text{ V}$		-		-23	dB
V_{TDC}	DTMF Output DC Level	$R_L = 5\text{ k}\Omega$, $V_{CC} = 2.0 \sim 5.5\text{ V}$		1.1		2.8	V
I_{TL}	Minimum DTMF Sink Output Current	$V_{TO} = 0.5\text{ V}$		0.2			mA
I_{PL}	Minimum \overline{DP} Sink Output Current	$V_{PO} = 0.5\text{ V}$		0.5			mA
I_{ML}	Minimum T/P \overline{MUTE} Sink Output Current	$V_{MO} = 0.5\text{ V}$		0.5			mA
R_{KH}	\overline{HKS} I/P Pull High Resister				300		$\text{k}\Omega$
I_{HFH}	Minimum HFO Drive/Sink Current	$V_{HFH} = 2.0\text{ V}$		0.5		-	mA
I_{HFL}		$V_{HFL} = 0.5\text{ V}$		0.5		-	
I_{Kd}	Keypad Input Drive Current	$V_{IN} = 0\text{ V}$		4		30	μA
I_{KS}	Minimum Keypad Input Sink Current	$V_{IN} = 2.5\text{ V}$		200		-	μA
	Maximum Keypad Resistance			-		5.0	$\text{k}\Omega$

* - from -20°C to $+70^\circ\text{C}$ values of parameters are specifying.

AC ELECTRICAL CHARACTERISTICS(All Voltages referenced to GND. $V_{CC}= 2.0\text{ V to }5.5\text{ V}$, $T_A = 25^\circ\text{C}^*$)

Symbol	Parameter	Test Conditions	Guaranteed Limits			Unit
			Min	Typ	Max	
T_{KID}	Keypad Active in Debounce (Figures 1,2,4-6)		-	20	-	ms
T_{KRD}	Key Release Debounce (Figure 2)		-	20	-	ms
T_{PDP}	Pre-Digit-Pause (Figures 1,4,5)	M/B = 2/3	-	40	-	ms
		M/B = 1/2	-	33.3	-	
T_{IDP}	Inter Digit Pause Time (Auto Dialing) (Figures 1,2,4,5)		-	800	-	ms
M/B	Make/Break Ratio	M/B = 2/3	-	40/60	-	%
		M/B = 1/2	-	33/67	-	
T_{TD}	DTMF Output Duration (Figure 2)	Auto Dialing	-	100	-	ms
T_{ITP}	Inter Tone Pause (Figure 2)		-	100	-	ms
T_{FB}	Flash Break Time (Figure 6)		-	600	-	ms
T_P	Pause Time (Figure 5)		-	3.6	-	s

* - from -20°C to $+70^\circ\text{C}$ values of parameters are specifying

Comparisons of Specified vs. Actual Tone Frequencies

R/C	Spec.	Actual	Error(%)	Unit	Conditions
R1	697	699	+0.28	Hz	$F_{osc} = 3.579\text{ MHz}$
R2	770	766	-0.52	Hz	
R3	852	848	-0.47	Hz	
R4	941	948	+0.74	Hz	
C1	1209	1216	+0.57	Hz	
C2	1336	1332	-0.30	Hz	
C3	1477	1472	-0.34	Hz	

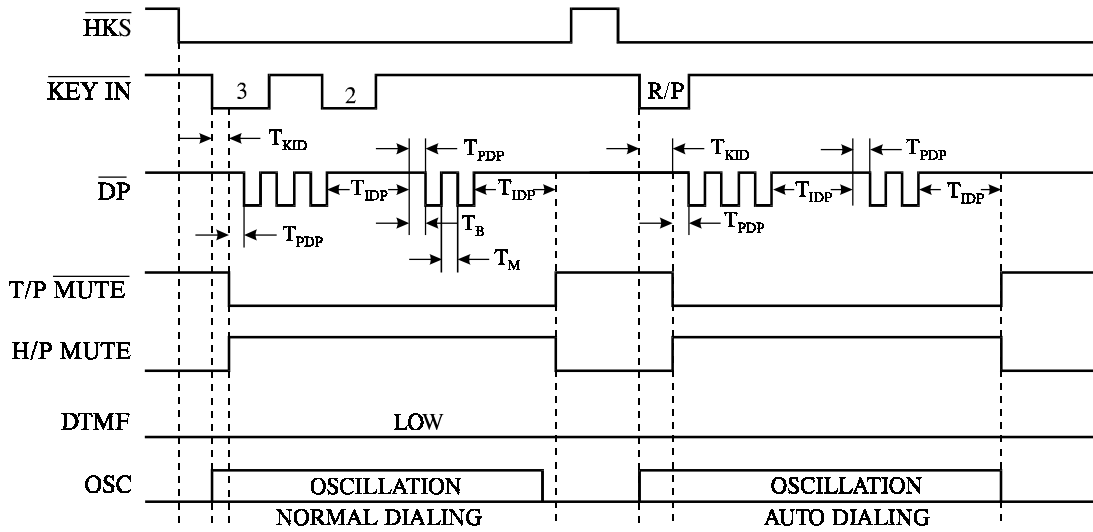

Figure 1. Pulse Mode

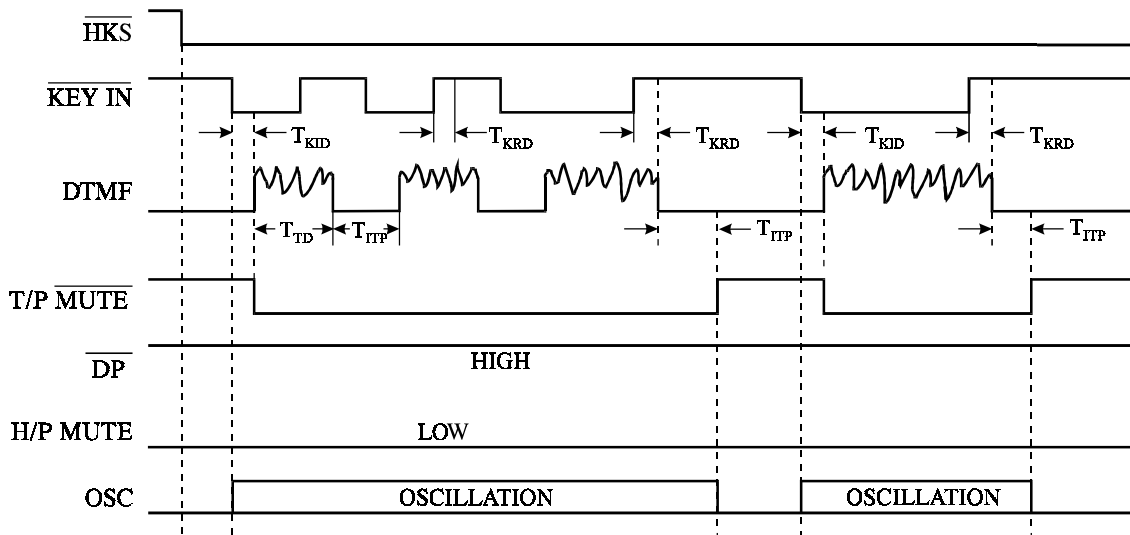

Figure 2(a). Tone Mode Normal Dialing

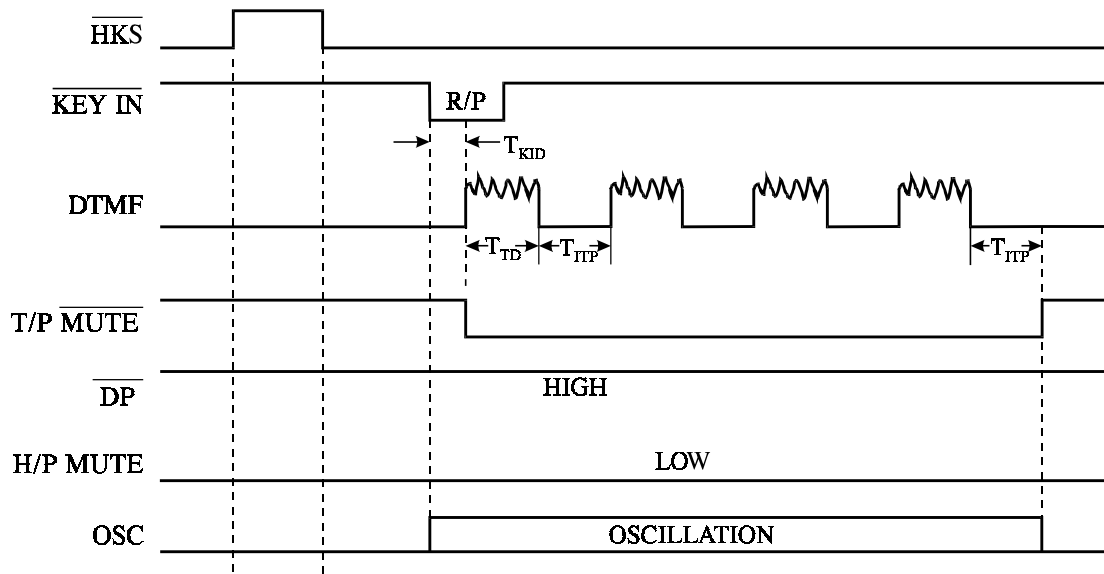

Figure 2(b). Tone Mode Auto Dialing

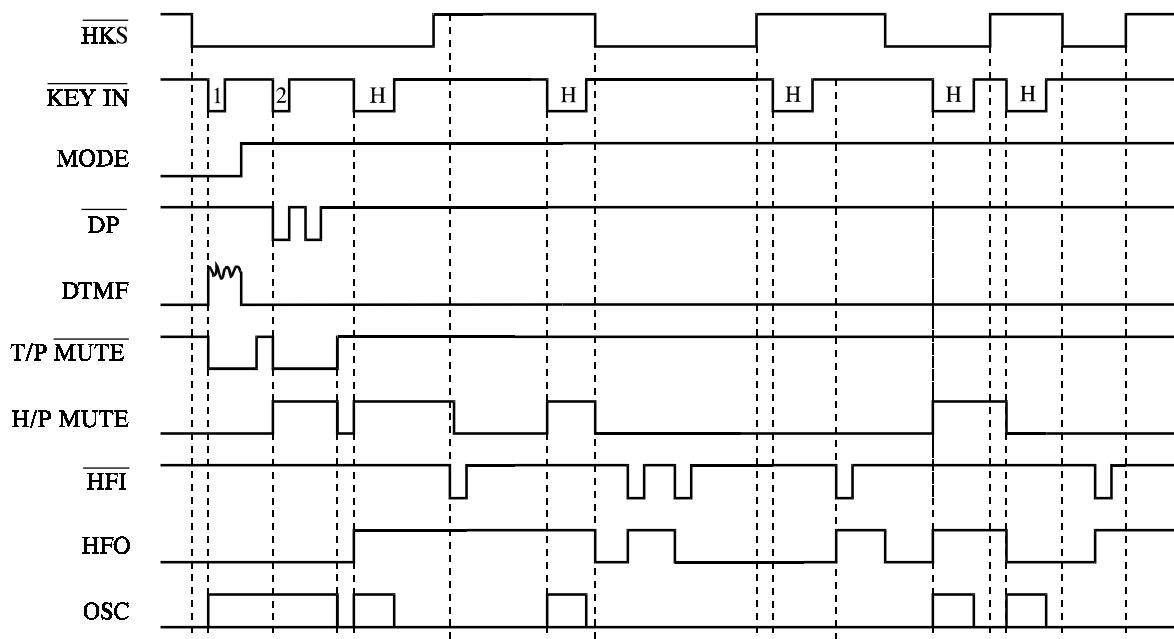

Figure 3. Control Function and Hold Function Relationship

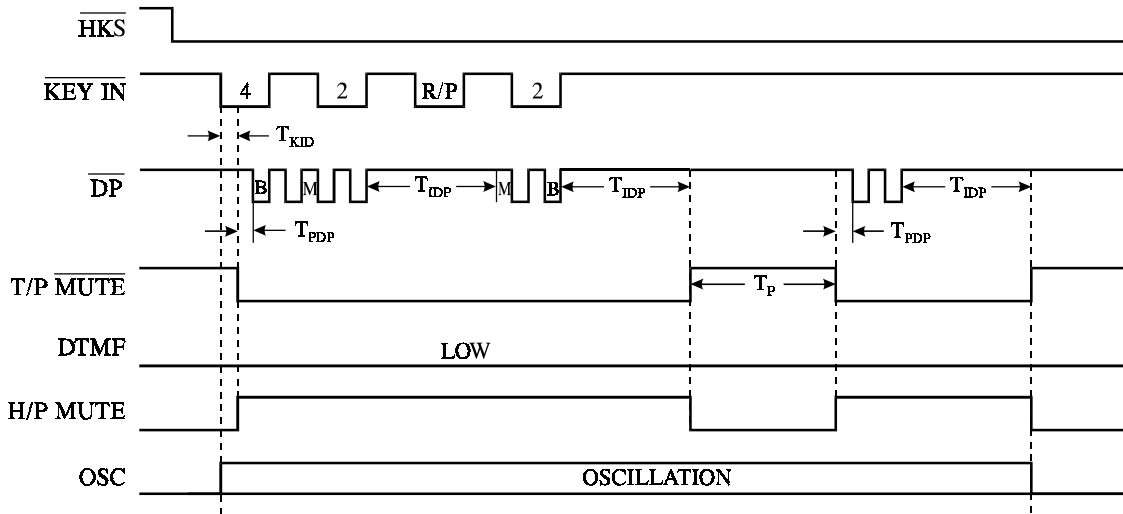

Figure 4. Pause Function

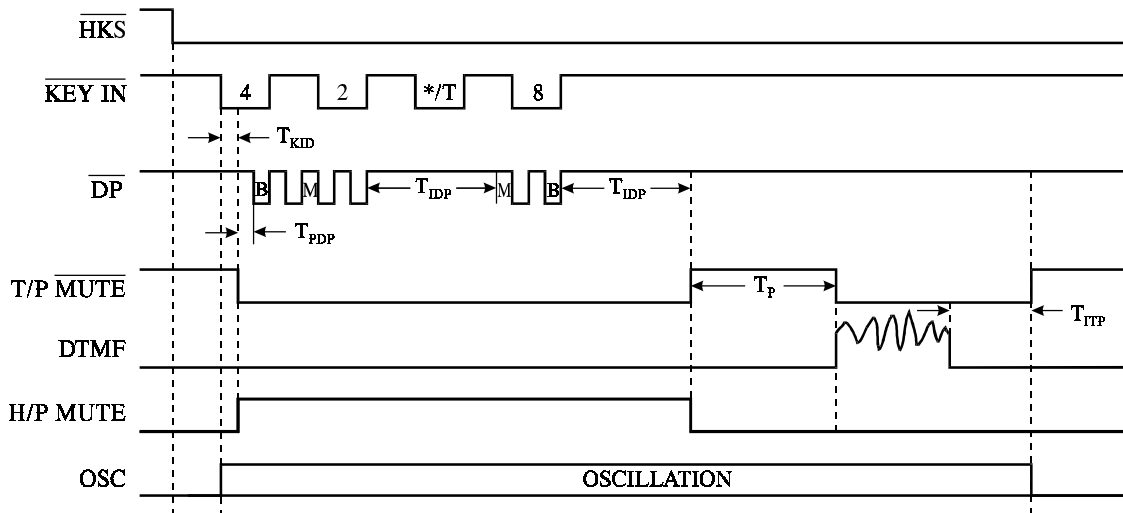

Figure 5. P - - >T Operation in Normal Dialing

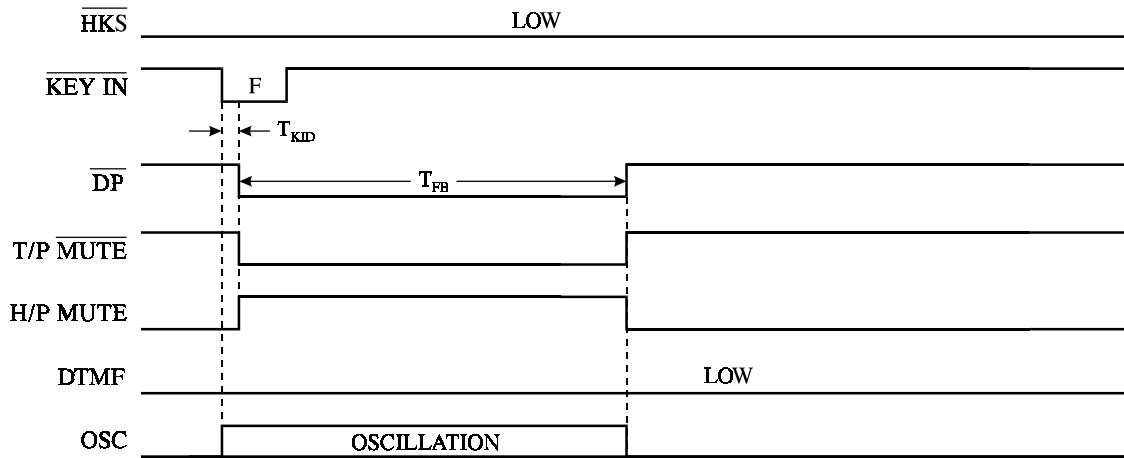

Figure 6. Flash Operatio

EXPANDED LOGIC DIAGRAM

