

## High Intensity SMD LED

Color	Type	Technology	Angle of Half Intensity $\pm\varphi$
White	TLMW310.	InGaN / YAG on SiC	60°

### Description

This device has been designed to meet the increasing demand for white SMD LED.

The package of the TLMW310. is the P-LCC-2 (equivalent to a size B tantalum capacitor).

It consists of a lead frame which is embedded in a white thermoplast. The reflector inside this package is filled with a mixture of epoxy and YAG phosphor.

The YAG phosphor converts the blue emission partially to yellow, which mixes with the remaining blue to give white.

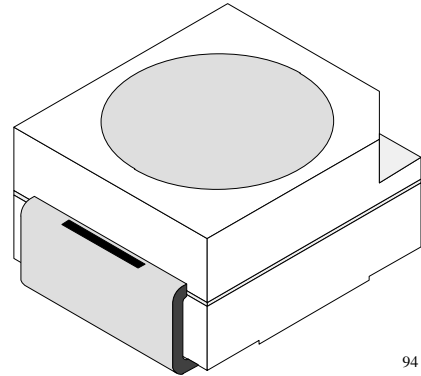

94 8553

### Features

- High efficient InGaN technology
- Chromaticity Coordinate categorized according to CIE1931 per packing unit
- Luminous intensity ratio in one packing unit  
 $I_{Vmax}/I_{Vmin} \leq 1.6$
- Typical color temperature 5500 K
- ESD class 1
- EIA and ICE standard package
- Compatible with infrared, vapor phase and wave solder processes according to CECC
- Available in 8 mm tape reel

### Applications

- Automotive:  
backlighting in dashboards and switches
- Telecommunication: indicator and backlighting in telephone and fax
- Backlighting for audio and video equipment
- Backlighting in office equipment
- Indoor and outdoor message boards
- Flat backlight for LCDs, switches and symbols
- Illumination purposes, alternative to incandescent lamps
- General use

### Absolute Maximum Ratings

$T_{amb} = 25^{\circ}\text{C}$ , unless otherwise specified

**TLMW310.**, , , ,

Parameter	Test Conditions	Symbol	Value	Unit
Reverse voltage		$V_R$	5	V
DC forward current	$T_{amb} \leq 70^{\circ}\text{C}$	$I_F$	20	mA
Surge forward current	$t_p \leq 10 \mu\text{s}$	$I_{FSM}$	0.1	A
Power dissipation	$T_{amb} \leq 70^{\circ}\text{C}$	$P_V$	85	mW
Junction temperature		$T_j$	100	$^{\circ}\text{C}$
Operating temperature range		$T_{amb}$	- 40 to + 100	$^{\circ}\text{C}$
Storage temperature range		$T_{stg}$	- 40 to + 100	$^{\circ}\text{C}$
Soldering temperature	$t \leq 5 \text{ s}$	$T_{sd}$	260	$^{\circ}\text{C}$
Thermal resistance junction/ambient	mounted on PC board (pad size > 16 mm <sup>2</sup> )	$R_{thJA}$	350	K/W

### Optical and Electrical Characteristics

$T_{amb} = 25^{\circ}\text{C}$ , unless otherwise specified

**White (TLMW310.)**

Parameter	Test Conditions	Type	Symbol	Min.	Typ.	Max.	Unit
Luminous intensity <sup>1)</sup>	$I_F = 20 \text{ mA}$	TLMW3100	$I_V$	80	140		mcd
	$I_F = 20 \text{ mA}$	TLMW3101	$I_V$	80		200	mcd
	$I_F = 20 \text{ mA}$	TLMW3102	$I_V$	125		320	mcd
Chromaticity coordinate x acc. to CIE 1931	$I_F = 20 \text{ mA}$	TLMW3100	x		0.33		
Chromaticity coordinate y acc. to CIE 1931	$I_F = 20 \text{ mA}$	TLMW3100	y		0.33		
Angle of half intensity	$I_F = 20 \text{ mA}$		$\phi$		$\pm 60$		deg
Forward voltage	$I_F = 20 \text{ mA}$		$V_F$		3.5	4.2	V
Reverse voltage	$I_R = 10 \mu\text{A}$		$V_R$	5			V
Temperature coefficient of $V_F$	$I_F = 20 \text{ mA}$		$TC_{VF}$		- 4		mV/K
Temperature coefficient of $I_V$	$I_F = 20 \text{ mA}$		$TC_{IV}$		- 0.5		% / K
<sup>1)</sup> in one Packing Unit $I_{VMin.}/I_{VMax.} \leq 1.6$							

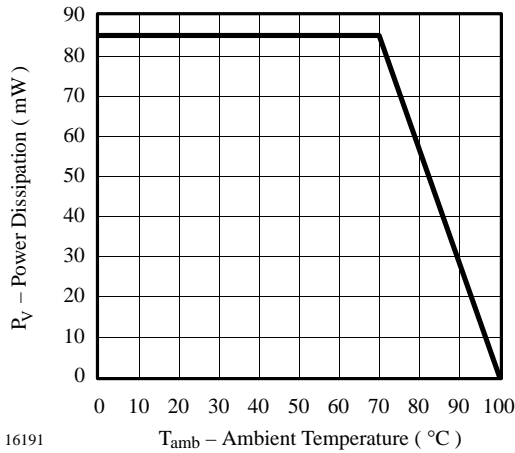
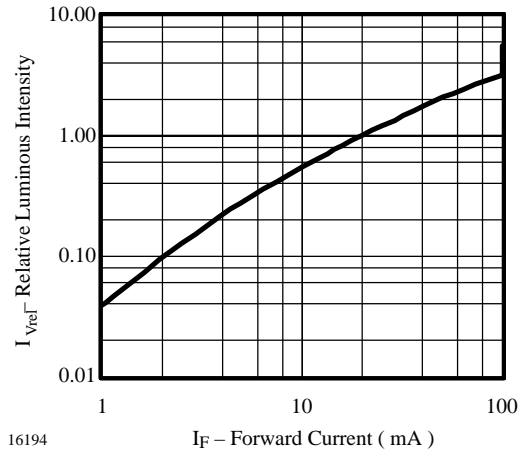
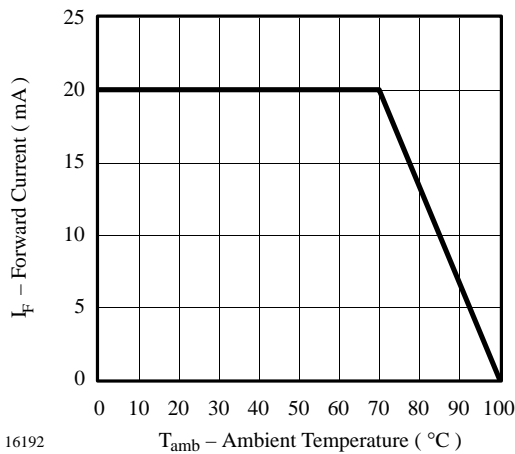
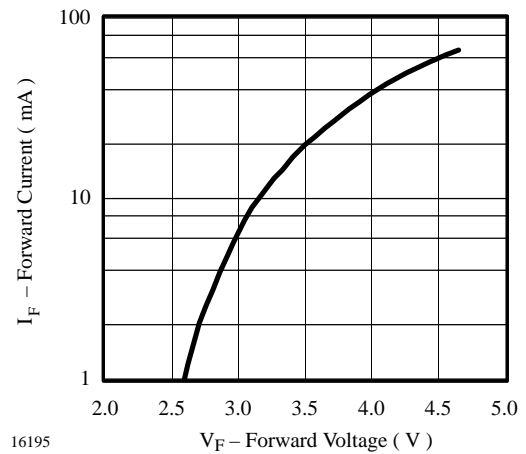
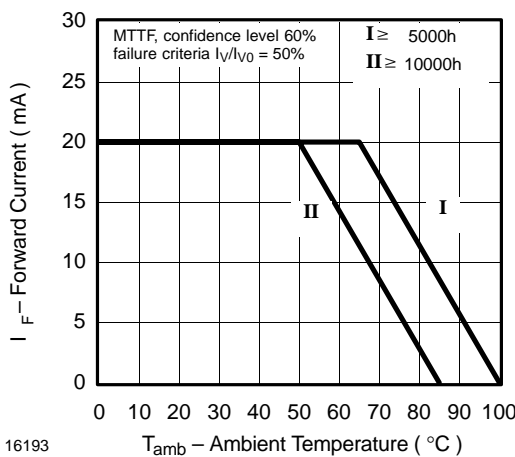
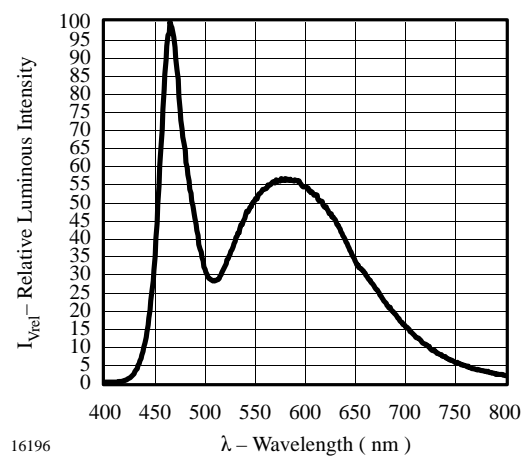
**Typical Characteristics** ( $T_{amb} = 25^{\circ}\text{C}$ , unless otherwise specified)

**Figure 1. Power Dissipation vs. Ambient Temperature**

**Figure 4. Relative Luminous Intensity vs. Forward Current**

**Figure 2. Forward Current vs. Ambient Temperature**

**Figure 5. Forward Current vs. Forward Voltage**

**Figure 3. Forward Current vs. Ambient Temperature**

**Figure 6. Relative Luminous Intensity vs. Wavelength**

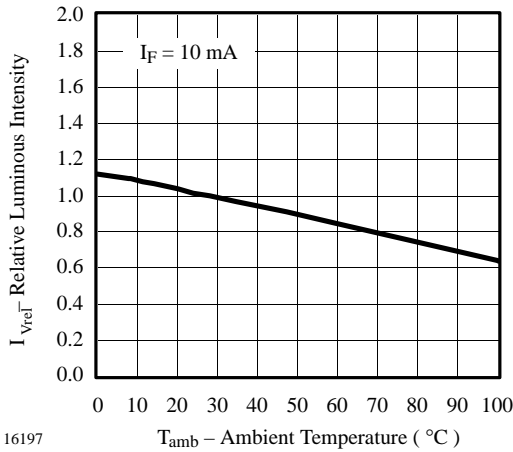

Figure 7. Rel. Luminous Intensity vs. Ambient Temperature

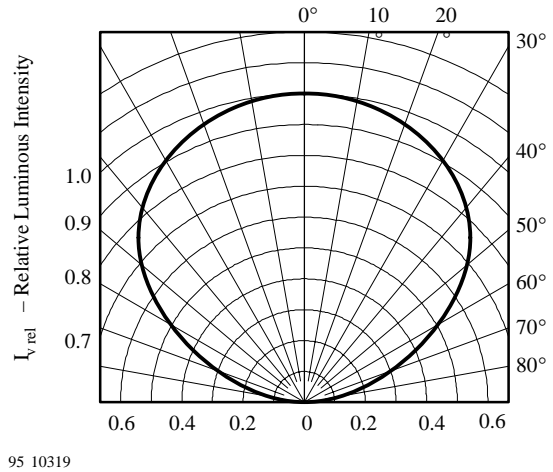

Figure 10. Rel. Luminous Intensity vs. Angular Displacement

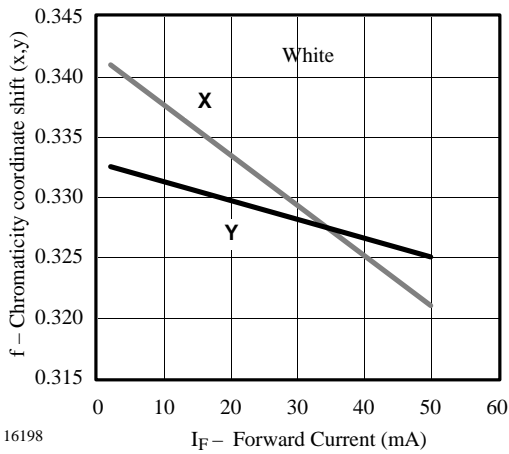

Figure 8. Chromaticity Coordinate Shift vs. Forward Current

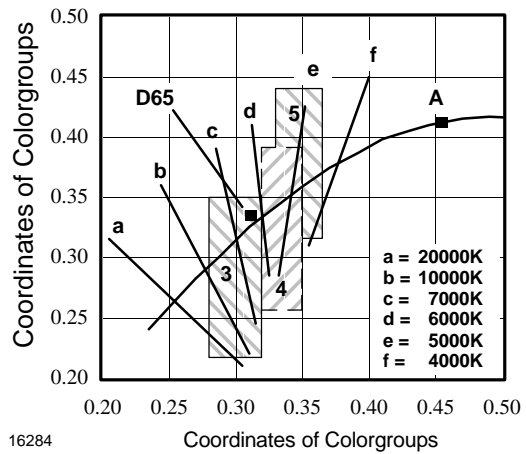

Figure 11. Coordinates of Colorgroups

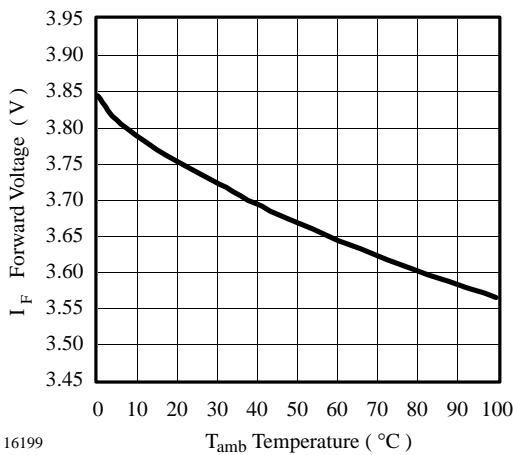
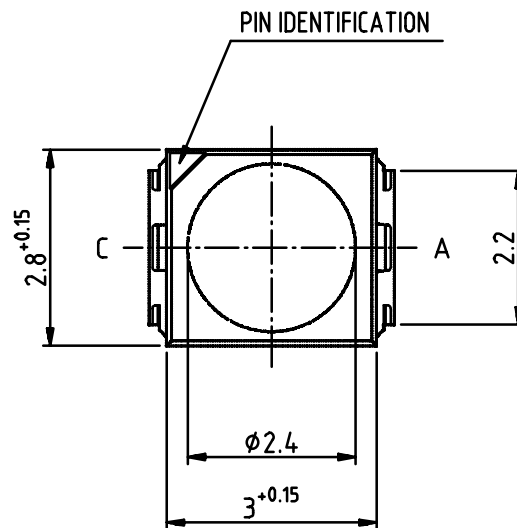
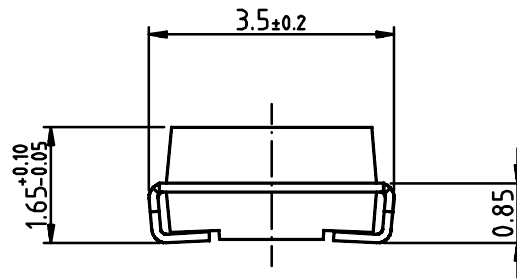
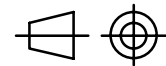

Figure 9. Forward Voltage vs. Ambient Temperature

**Dimensions in mm**



95 11314



technical drawings  
according to DIN  
specifications

**Dimensions in mm**

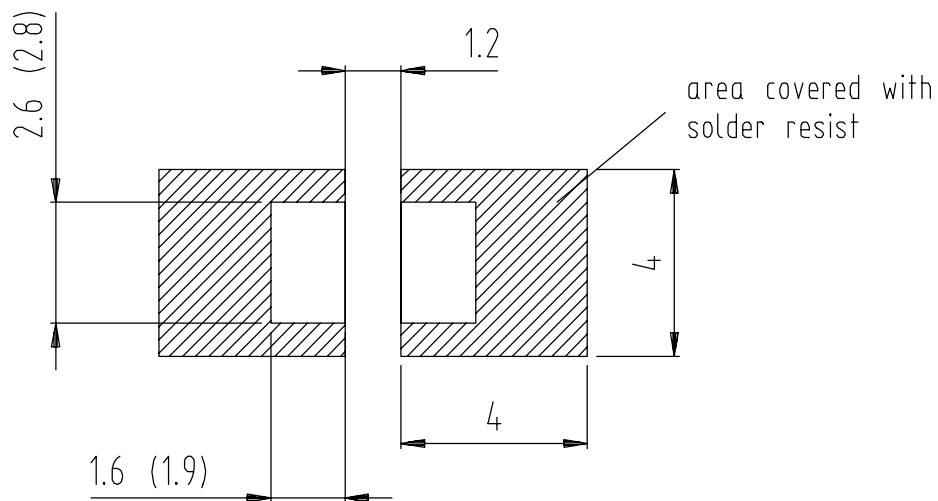

Dimensions: IR and Vaporphase  
( Wave Soldering )

95 10966

### Ozone Depleting Substances Policy Statement

It is the policy of **Vishay Semiconductor GmbH** to

1. Meet all present and future national and international statutory requirements.
2. Regularly and continuously improve the performance of our products, processes, distribution and operating systems with respect to their impact on the health and safety of our employees and the public, as well as their impact on the environment.

It is particular concern to control or eliminate releases of those substances into the atmosphere which are known as ozone depleting substances (ODSs).

The Montreal Protocol (1987) and its London Amendments (1990) intend to severely restrict the use of ODSs and forbid their use within the next ten years. Various national and international initiatives are pressing for an earlier ban on these substances.

**Vishay Semiconductor GmbH** has been able to use its policy of continuous improvements to eliminate the use of ODSs listed in the following documents.

1. Annex A, B and list of transitional substances of the Montreal Protocol and the London Amendments respectively
2. Class I and II ozone depleting substances in the Clean Air Act Amendments of 1990 by the Environmental Protection Agency (EPA) in the USA
3. Council Decision 88/540/EEC and 91/690/EEC Annex A, B and C (transitional substances) respectively.

**Vishay Semiconductor GmbH** can certify that our semiconductors are not manufactured with ozone depleting substances and do not contain such substances.

**We reserve the right to make changes to improve technical design and may do so without further notice.**

Parameters can vary in different applications. All operating parameters must be validated for each customer application by the customer. Should the buyer use Vishay Semiconductors products for any unintended or unauthorized application, the buyer shall indemnify Vishay Semiconductors against all claims, costs, damages, and expenses, arising out of, directly or indirectly, any claim of personal damage, injury or death associated with such unintended or unauthorized use.

Vishay Semiconductor GmbH, P.O.B. 3535, D-74025 Heilbronn, Germany  
Telephone: 49 (0)7131 67 2831, Fax number: 49 (0)7131 67 2423