

PRODUCT NUMBER

75869-YXXLF

RoHS COMPATIBLE, SEE NOTE 5

PIN STYLE, SEE SHEET 2 & 3.

PLATING SEE SHEET 2 & 3.

NOTES:

- 1 - HOUSING MAT'L : GLASS FILLED THERMOPLASTIC. UL94V-0 COLOR: BLUE PART MEETS WITH GWT (725°C;960°C)
- 2 - PIN MATERIAL : PHOSPHOR BRONZE
- 3 - PACKAGING :
POLYBAGS FROM 2X02 TO 2X04 POSITIONS
TUBE FROM 2X05 TO 2X32 POSITIONS
- 4 - TO DETERMINE DIMENSIONS :
N = NUMBER OF POSITIONS PER ROW
EXAMPLE : 8 POS N x 2.54 = 20.32mm
- 5 - RoHS COMPATIBLE PRODUCT SPECIFICATIONS
 - a - PLATING:
- "LF" MEANS THE PRODUCT IS LEAD-FREE, 2µm MINIMUM MATTE TIN OVER 1.27µm MINIMUM NICKEL UNDERPLATE.
 - b - MANUFACTURING PROCESS COMPATIBILITY
- THE HOUSING WILL WITHSTAND EXPOSURE TO 260°C ±5°C SOLDER BATH TEMPERATURE FOR 5 SECONDS IN A WAVE SOLDER APPLICATION WITH A 1.6mm MIN THICK CIRCUIT BOARD.
 - c - LABELLING:
- MEETS PACKAGING SPECS AS PER GS-14-920
 - d - LEGAL STATEMENT: SEE GS-47-0004

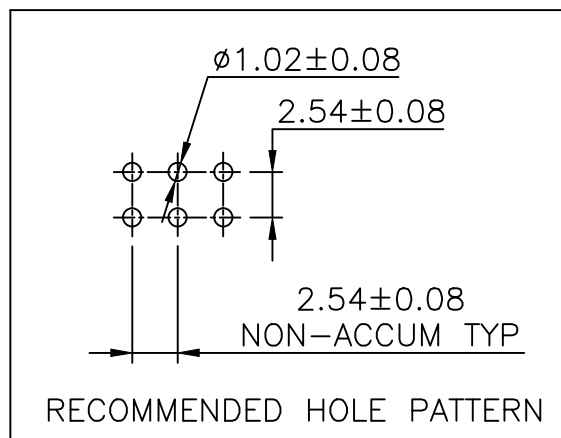
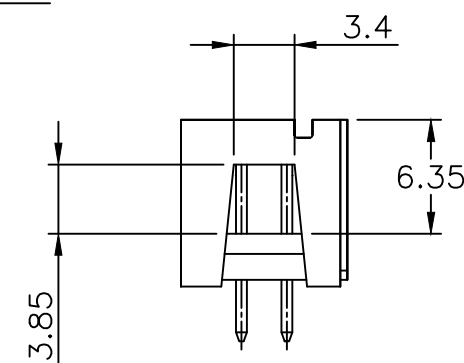
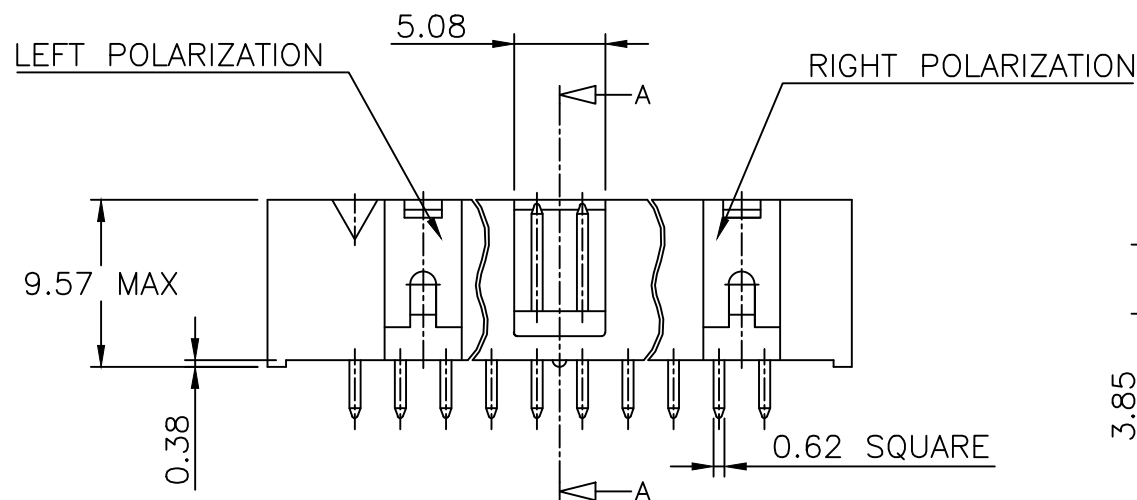
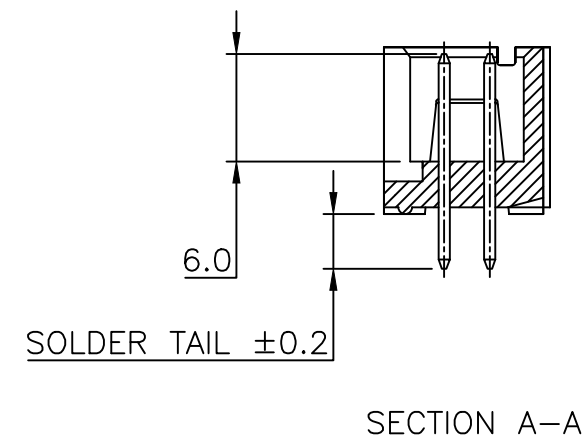
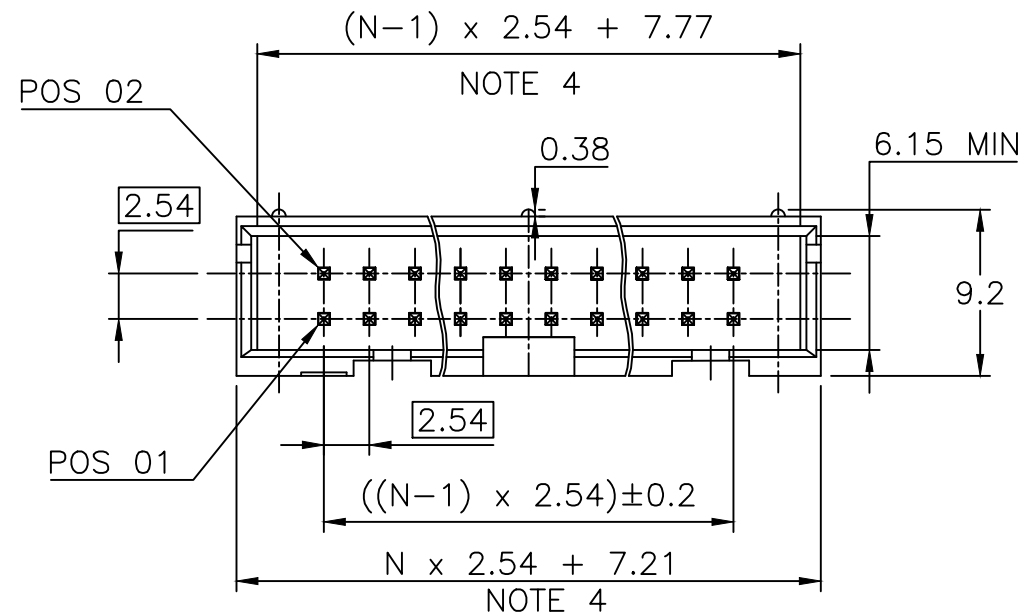

mat'l. code SEE NOTES				surface ISO 1302	tolerance ISO 406 ISO 1101	projection mm	product family QUICKIE
ltr	ecn no	dr	date	tolerances unless otherwise specified		scale 2.5:1	title SHR.LP.HEADER STR DR TMT
BK	F12-0086	JCO	12.07.17	angles	.X ±0.3		
BL	F12-0805	LMU	12.10.25	linear	.XX ±0.13	FCJ	dwg no 75869
BM	B-18120	LMU	14.07.10		.XXX ±0.05		
BN	B-19070	LMU	14.10.15	dr	D.LE 01.01.24	sheet 1 of 3	size A3
BP	B-19091	LMU	14.10.16	engr	JM.C 01.01.24		
				chr	JF.N 01.01.24	type CUSTOMER Drawing	
				appd	JM.C 01.01.24		
sheet index	revision sheet	BP	BE	J			
		1	2	3			

STANDARD APPLICATION

PIN STYLE	NUMBER OF POSITIONS	SOLDER TAIL REF	LEFT POLARIZATION	RIGHT POLARIZATION
30	2 x 2	3.05	NO	NO
31	2 x 3	3.05	NO	NO
32	2 x 4	3.05	NO	NO
01	2 x 5	3.05	NO	YES
02	2 x 7	3.05	NO	YES
03	2 x 8	3.05	YES	YES
04	2 x 10	3.05	YES	YES
05	2 x 13	3.05	YES	YES
33	2 x 15	3.05	YES	YES
06	2 x 17	3.05	YES	YES
07	2 x 20	3.05	YES	YES
08	2 x 25	3.05	YES	YES
09	2 x 30	3.05	YES	YES
10	2 x 32	3.05	YES	YES

PLATING :

- 1 = 0.76µm GOLD/GXT
(PdNi WITH GOLD FLASH) ON CONTACT AREA
2µm MIN MATTE TIN ON TAIL
- 2 = 2µm TIN MIN FULL PLATED
- 3 = 0.38µm GOLD/GXT
(PdNi WITH GOLD FLASH) ON CONTACT AREA
2µm MIN MATTE TIN ON TAIL

UNDERPLATE : 1.27µm Ni MIN



Copyright FCI

mat'l. code		surface		tolerance		projection		product family	
		ISO 1302 ✓		ISO 406 ISO 1001				QUICKIE	
ltr	ecn no	dr	date	tolerances unless otherwise specified				title	
BC	F08-0137	LMU	08.03.10	angles	linear			SHR.LP.HEADER	
BD	F08-0146	YOV	08.04.11			scale N/A		STR DR TMT	
BE	B-19091	LMU	14.10.16					dwg no	
AY	F04-0389	JCO	04.12.22	dr	D.LE	01.01.24	sheet 2 of - size		
BA	F06-0229	LMU	06.07.18	enrg	JM.C	01.01.24	75869 A3		
BB	F07-0198	LMU	07.05.30	chr	JF.N	01.01.24	type		
sheet index		revision sheet						CUSTOMER Drawing	

1

2

4

5

6

APPLICATION SPECIFIC

PIN STYLE	NUMBER OF POSITIONS	SOLDER TAIL REF	PIN MISSING	LEFT POLARIZATION	RIGHT POLARIZATION
44	2x03	3.05	PIN 2	NO	NO
40	2x03	3.05	PIN 6	NO	NO
51	2x03	7.60		NO	NO
41	2x04	3.05	PIN 1	NO	NO
55	2x04	3.05	PIN 8	NO	NO
64	2x04	4.10		NO	NO
59	2x05	3.05	PIN 1,2,9,10	NO	YES
60	2x05	3.05	PIN 9	NO	YES
37	2x07	3.05	PIN 1	NO	YES
13	2x07	3.05	PIN 3	NO	YES
14	2x07	3.05	PIN 5	NO	YES
46	2x07	3.05	PIN 6	NO	YES
12	2x07	3.05	PIN 7	NO	YES
57	2x07	3.05	PIN 12	NO	YES
11	2x07	3.05	PIN 13	NO	YES
56	2x07	3.05	PIN 14	NO	YES
43	2x08	3.05	PIN 6 & 7	YES	YES
38	2x10	3.05	PIN 2	YES	YES
34	2x10	3.05	PIN 15	YES	YES
58	2x10	3.05	PIN 18	YES	YES
63	2x10	7.60		YES	YES
35	2x13	3.05	PIN 26	YES	YES
25	2x13	7.60		YES	YES
54	2x15	7.60		YES	YES
19	2x15	4.10		YES	YES
17	2x17	3.05	PIN 3	YES	YES
39	2x17	3.05	PIN 5	YES	YES
26	2x17	7.60		YES	YES
15	2x20	3.05	PIN 8	YES	YES
16	2x20	3.05	PIN 17	YES	YES
18	2x20	3.05	PIN 20	YES	YES
36	2x20	3.05	PIN 37	YES	YES
45	2x20	3.05	PIN 25,27,28	YES	YES
27	2x20	7.60		YES	YES
42	2x25	3.05	PIN 25	YES	YES
28	2x25	7.60		YES	YES
62	2x25	4.10		YES	YES

PLATING :

- 1 = 0.76µm GOLD/GXT
(PdNi WITH GOLD FLASH) ON CONTACT AREA
2µm MIN MATTE TIN ON TAIL
- 2 = 2µm TIN MIN FULL PLATED
- 3 = 0.38µm GOLD/GXT
(PdNi WITH GOLD FLASH) ON CONTACT AREA
2µm MIN MATTE TIN ON TAIL

UNDERPLATE : 1.27µm Ni MIN



Copyright FCI

mat'l. code		surface		tolerance		projection		product family	
		ISO 1302 ✓		ISO 406 ISO 1001				QUICKIE	
ltr	ecn no	dr	date	tolerances unless otherwise specified		mm		title	
H	B-18120	LMU	14.07.10	angles	linear			SHR.LP.HEADER	
J	B-19091	LMU	14.10.16			scale N/A		STR DR TMT	
D	F07-0198	LMU	07.05.30	dr	MULIN.L	02.01.29		dwg no	
E	F08-0146	YOV	08.04.11	enrg	COMPAGNON.J	02.01.29		sheet 3 of - size	
F	F10-0217	LMU	10.09.16	chr	NOTTEAU.JF	02.01.29		75869 A3	
G	F12-0086	JCO	12.07.17	appd	JM.C	02.01.29		type CUSTOMER Drawing	
sheet	revision								
index	sheet								

1

2

3

4

5

6