



Micro Commercial Components



Micro Commercial Components  
20736 Marilla Street Chatsworth  
CA 91311  
Phone: (818) 701-4933  
Fax: (818) 701-4939

# MJD31C

## Silicon NPN epitaxial planer Transistors

### Features

- Lead Free Finish/RoHS Compliant ("P" Suffix designates RoHS Compliant. See ordering information)
- Epoxy meets UL 94 V-0 flammability rating
- Moisture Sensitivity Level 1
- Electrically Similar to Popular TIP31 and TIP32 Series
- Designed for general purpose amplifier and low speed switching applications.
- Maximum Thermal Resistance: 100°C/W Junction to Ambient

### Maximum Ratings @ 25°C Unless Otherwise Specified

Symbol	Rating	Rating	Unit
V <sub>CEO</sub>	Collector-Emitter Voltage	100	V
V <sub>CBO</sub>	Collector-Base Voltage	100	V
V <sub>EBO</sub>	Emitter-Base Voltage	5	V
I <sub>C</sub>	Collector Current-Continuous	3	A
P <sub>C</sub>	Collector Dissipation	1.25	W
T <sub>J</sub>	Operating Junction Temperature	150	°C
T <sub>STG</sub>	Storage Temperature	-65 to +150	°C

### Electrical Characteristics @ 25°C Unless Otherwise Specified

Symbol	Parameter	Min	Typ	Max	Units
V <sub>(BR)CEO</sub>	Collector-Emitter Breakdown Voltage (I <sub>C</sub> =30mA, I <sub>B</sub> =0)	100	---	---	Vdc
V <sub>(BR)CBO</sub>	Collector-Base Breakdown Voltage (I <sub>C</sub> =1mA, I <sub>E</sub> =0)	100	---	---	Vdc
V <sub>(BR)EBO</sub>	Emitter-Base Breakdown Voltage (I <sub>E</sub> =1mA, I <sub>C</sub> =0)	5	---	---	Vdc
I <sub>CEO</sub>	Collector Cutoff Current (V <sub>CE</sub> =60Vdc, I <sub>B</sub> =0)	---	---	50	uAdc
I <sub>CES</sub>	Collector Cutoff Current (V <sub>CE</sub> =100Vdc, V <sub>EB</sub> =0)	---	---	20	uAdc
I <sub>EBO</sub>	Emitter Cutoff Current (V <sub>EB</sub> =5Vdc, I <sub>C</sub> =0)	---	---	1	mAdc
h <sub>FE</sub>	DC Current Gain (I <sub>C</sub> =1Adc, V <sub>CE</sub> =4Vdc) (I <sub>C</sub> =3Adc, V <sub>CE</sub> =4Vdc)	25 10	---	---	
V <sub>CE(sat)</sub>	Collector-Emitter Saturation Voltage (I <sub>C</sub> =3Adc, I <sub>B</sub> =0.375Adc) (note 1)	---	---	1.2	Vdc
V <sub>BE(on)</sub>	Base-Emitter Voltage (I <sub>C</sub> =3Adc, V <sub>CE</sub> =4Vdc) (note 1)	---	---	1.8	Vdc
f <sub>T</sub>	Transition frequency (V <sub>CE</sub> =10Vdc, I <sub>C</sub> =0.5Adc, f <sub>r</sub> =1KHz)	3	---	---	MHz

Note: 1. Pulse Test: PW≤300μs, Duty Cycle≤2%

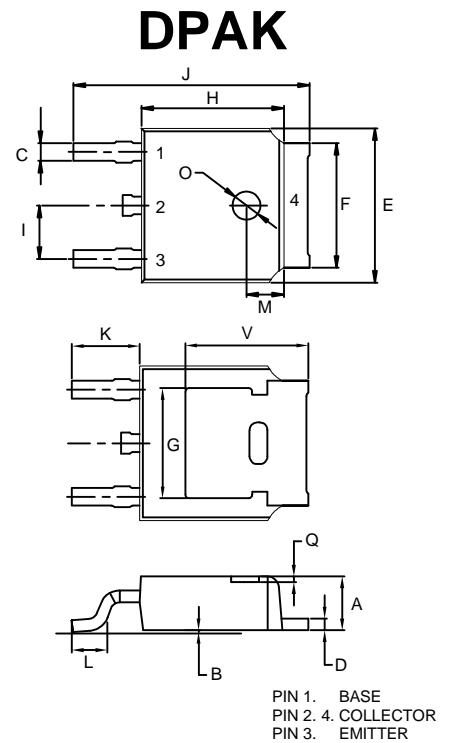

DIM	INCHES		MM		NOTE
	MIN	MAX	MIN	MAX	
A	0.087	0.094	2.20	2.40	
B	0.000	0.005	0.00	0.13	
C	0.026	0.034	0.66	0.86	
D	0.018	0.023	0.46	0.58	
E	0.256	0.264	6.50	6.70	
F	0.201	0.215	5.10	5.46	
G	0.190		4.83		
H	0.236	0.244	6.00	6.20	
I	0.086	0.094	2.18	2.39	
J	0.386	0.409	9.80	10.40	
K	0.114		2.90		
L	0.055	0.067	1.40	1.70	
M	0.063		1.60		
O	0.043	0.051	1.10	1.30	
Q	0.000	0.012	0.00	0.30	
V	0.211		5.35		

## TYPICAL CHARACTERISTICS

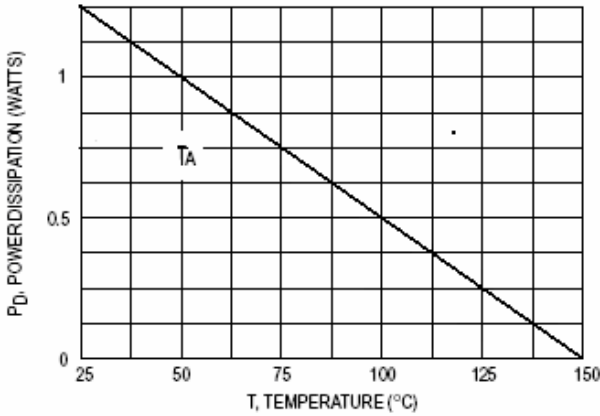
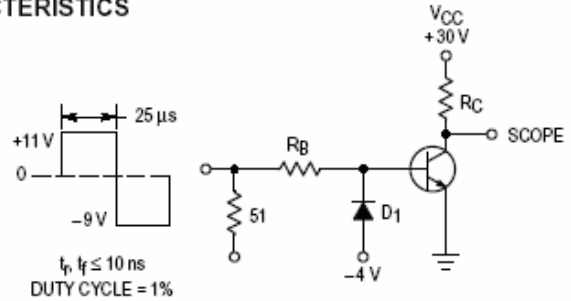

Figure 1. Power Derating



$R_B$  and  $R_C$  VARIED TO OBTAIN DESIRED CURRENT LEVELS  
 D1 MUST BE FAST RECOVERY TYPE, e.g.:  
 1N5825 USED ABOVE  $I_B \approx 100$  mA  
 MSD6100 USED BELOW  $I_B \approx 100$  mA  
 REVERSE ALL POLARITIES FOR PNP.

Figure 2. Switching Time Test Circuit

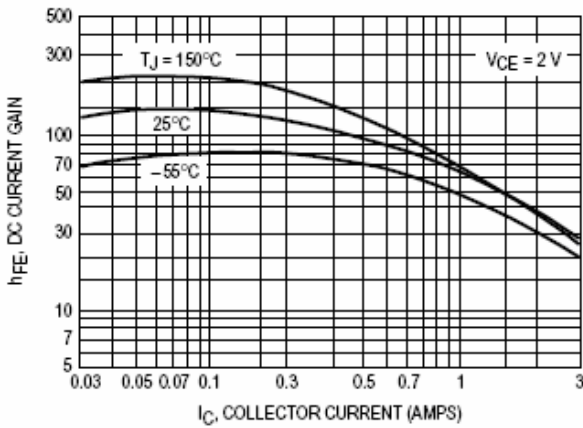

Figure 3. DC Current Gain

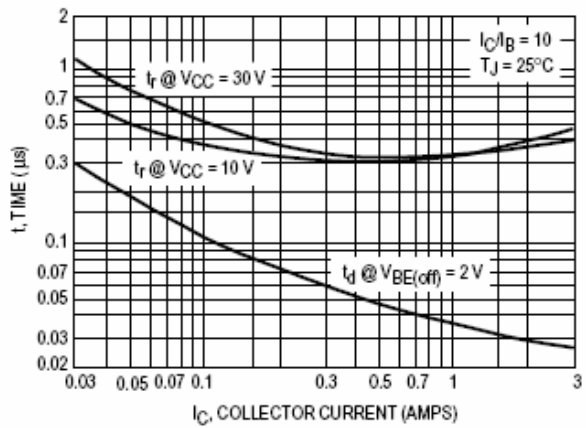

Figure 4. Turn-On Time

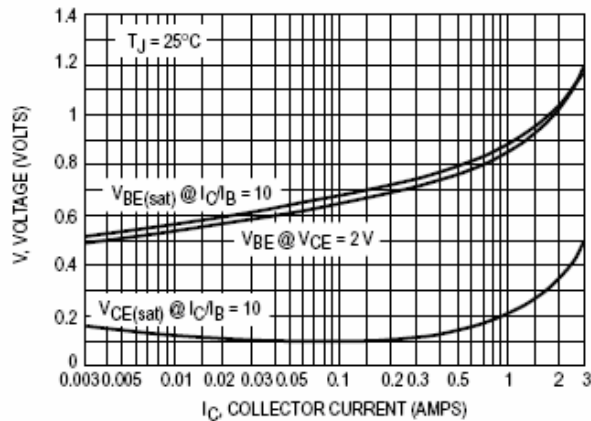

Figure 5. "On" Voltages

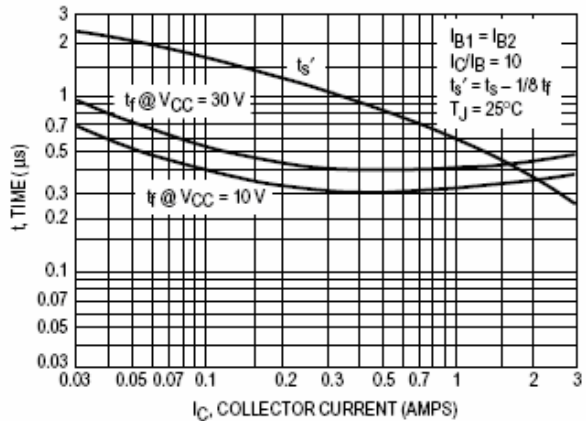

Figure 6. Turn-Off Time

# MJD31C

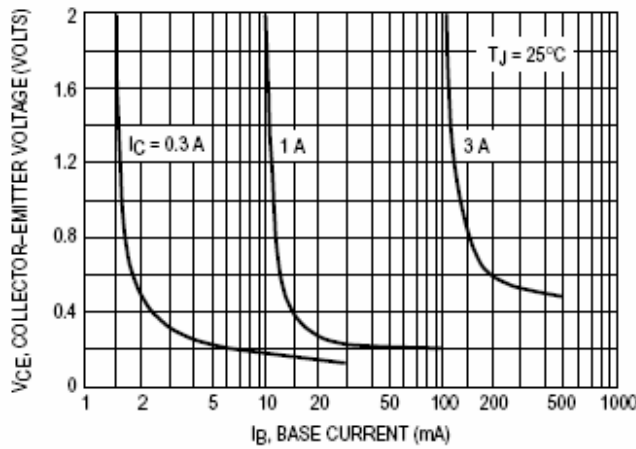

Figure 7. Collector Saturation Region

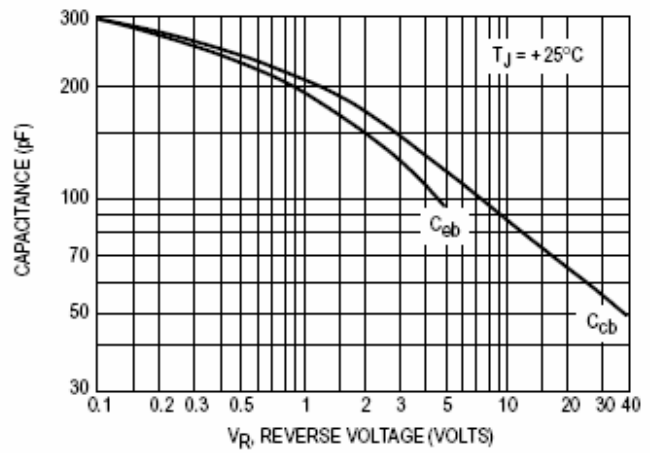

Figure 8. Capacitance

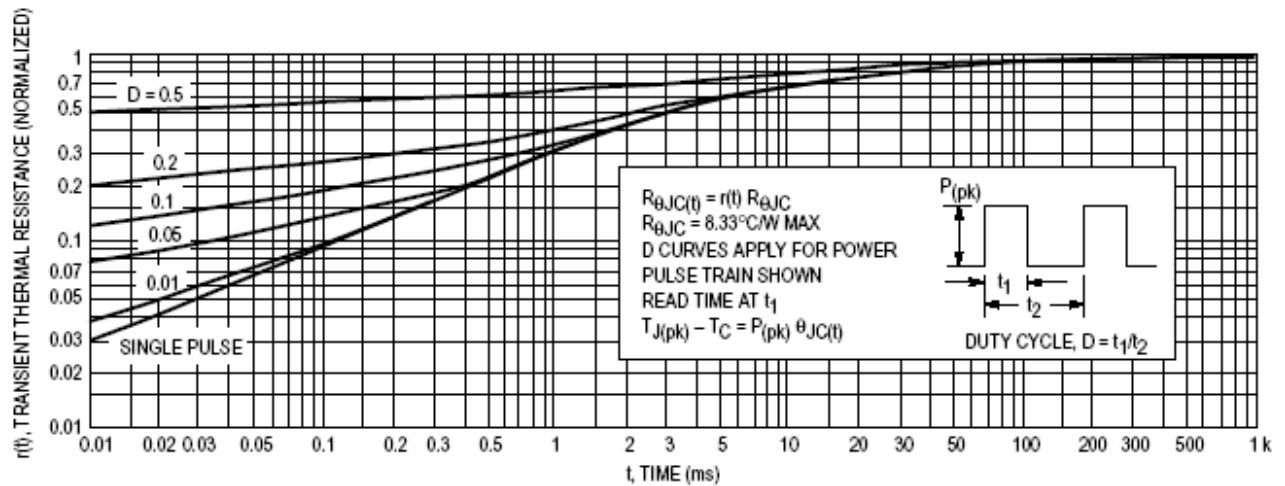

Figure 9. Thermal Response

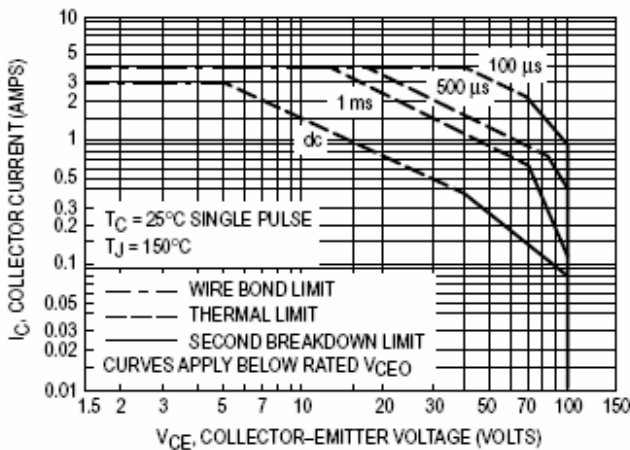

Figure 10. Active Region Safe Operating Area

There are two limitations on the power handling ability of a transistor: average junction temperature and second breakdown. Safe operating area curves indicate  $I_C - V_{CE}$  limits of the transistor that must be observed for reliable operation; i.e., the transistor must not be subjected to greater dissipation than the curves indicate.

The data of Figure 10 is based on  $T_{J(pk)} = 150^\circ\text{C}$ ;  $T_C$  is variable depending on conditions. Second breakdown pulse limits are valid for duty cycles to 10% provided  $T_{J(pk)} \leq 150^\circ\text{C}$ .  $T_{J(pk)}$  may be calculated from the data in Figure 9. At high case temperatures, thermal limitations will reduce the power that can be handled to values less than the limitations imposed by second breakdown.



Micro Commercial Components

Ordering Information :

Device	Packing
Part Number-TP	Tape&Reel: 2.5Kpcs/Reel

**\*\*\*IMPORTANT NOTICE\*\*\***

**Micro Commercial Components Corp.** reserves the right to make changes without further notice to any product herein to make corrections, modifications , enhancements , improvements , or other changes . **Micro Commercial Components Corp .** does not assume any liability arising out of the application or use of any product described herein; neither does it convey any license under its patent rights ,nor the rights of others . The user of products in such applications shall assume all risks of such use and will agree to hold **Micro Commercial Components Corp .** and all the companies whose products are represented on our website, harmless against all damages.

**\*\*\*LIFE SUPPORT\*\*\***

MCC's products are not authorized for use as critical components in life support devices or systems without the express written approval of Micro Commercial Components Corporation.

**\*\*\*CUSTOMER AWARENESS\*\*\***

Counterfeiting of semiconductor parts is a growing problem in the industry. Micro Commercial Components (MCC) is taking strong measures to protect ourselves and our customers from the proliferation of counterfeit parts. MCC strongly encourages customers to purchase MCC parts either directly from MCC or from Authorized MCC Distributors who are listed by country on our web page cited below. Products customers buy either from MCC directly or from Authorized MCC Distributors are genuine parts, have full traceability, meet MCC's quality standards for handling and storage. **MCC will not provide any warranty coverage or other assistance for parts bought from Unauthorized Sources.** MCC is committed to combat this global problem and encourage our customers to do their part in stopping this practice by buying direct or from authorized distributors.

[www.mccsemi.com](http://www.mccsemi.com)