

## Micropower 700mA Low Noise Fast Transient Response LDO

### General Description

The AMS3109 is a high performance linear regulator with very low dropout voltage and excellent transient response. It is designed to operate with wide input voltage range of 1.5 – 12Volts making it ideal for two step conversion while maintaining high efficiency for many power sensitive applications. The device is capable of supplying 700mA of output current with a typical dropout voltage of 550mV. The product is available in adjustable output voltage.

The linear regulator has been optimized for noise sensitive applications. The device includes an Enable pin for electrical on/off of the regulator. Forcing the Enable pin to logic low shuts down the LDO and reduces the supply current below 1 $\mu$ A.

The product includes complete short-circuit and thermal protection. The combination of these two internal protection circuits gives the device a comprehensive safety system to safe guard against extreme adverse operating conditions.

The AMS3109 is available in a thermally enhanced SOIC-8 EDP package, and it is rated for -40°C to +125°C temperature range.

### Features

- $V_{IN}$  range: 1.5 – 12V
- Adjustable output voltage as low as 0.6V
- 700mA maximum output current
- 550mV typical dropout voltage at 700mA
- Low self noise
- Enable (EN) pin for LDO on/off
- 120 $\mu$ A typical supply current
- ByPass ( $C_{BYP}$ ) Pin for low PSRR and output noise
- PSRR > 40dB at 10KHz
- Stable with Electrolytic, Tantalum or Ceramic capacitors
- Current Limit protection
- Over-Temperature Shutdown
- -40 to +125°C temperature range
- Thermally enhanced SOIC-8 exposed paddle package
- RoHS & WEEE compliant

### Applications

- ASIC Power Supplies In:
  - Set-top Boxes, Desktops, Notebooks
  - Graphic Cards, Printers and Copiers
- DVD, Blue-Ray DVD writers
- LCD TVs and LCD monitors
- Infotainment
- Wireless & RF: applications
- DSP and FPGA Power Supplies
- Medical Instrumentation
- SMPS Post-Regulator

### Typical Application

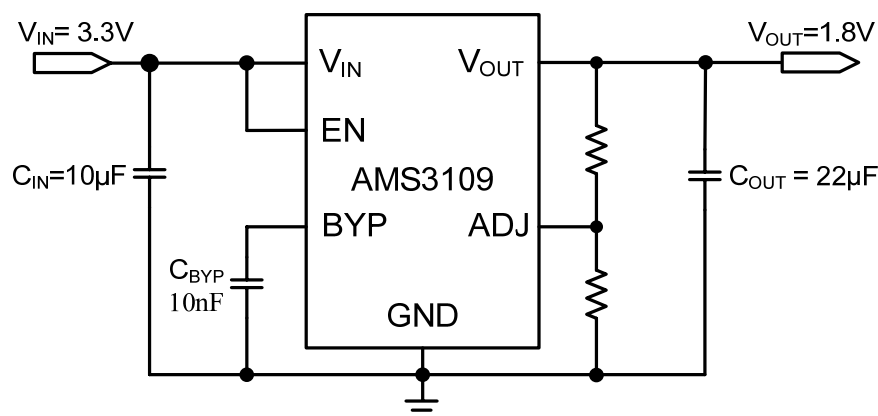

## Micropower 700mA Low Noise Fast Transient Response LDO

### Pin Description (SOIC-8 EDP package)

| Pin # | Symbol           | Description   |
|-------|------------------|---|
| 1     | BYP              | Reference Bypass pin. Connect an external capacitor from C <sub>BYP</sub> to ground to bypass the noise generated by the internal bandgap. This improves power supply rejection ratio and output noise. |
| 2     | NC               | No Connection   |
| 3     | GND              | Ground  |
| 4     | V <sub>IN</sub>  | Input supply Voltage. It powers the internal control circuitry and the internal power switch. Bypass V <sub>IN</sub> with at ceramic capacitor from this pin to ground.                                 |
| 5     | V <sub>OUT</sub> | Output Voltage  |
| 6     | ADJ              | Provides feedback to error amplifier from the resistive divider that sets the output voltage.   |
| 7     | NC               | No Connection   |
| 8     | EN               | Enable pin. It controls the electrical on/off of the device. When connected to logic low, the device shuts off and consumes less than 1μA of current. Logic high will resume normal operation.          |
| 9     | GND              | Expose pad. Connected to PCB ground plane for good thermal dissipation.   |

### Pin Configuration

SOIC-8EDP (Top View)

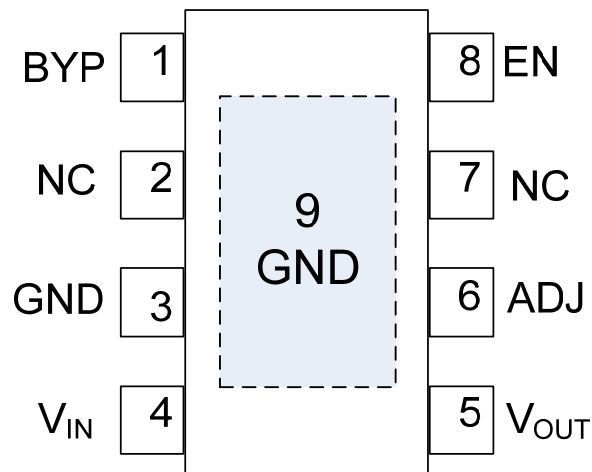

## Micropower 700mA Low Noise Fast Transient Response LDO

### Absolute Maximum Ratings <sup>(1)</sup>

|  |                |
|--|----------------|
| Maximum Input Supply Voltage ( $V_{IN}$ )..... | -0.3V to 15V   |
| Enable Voltage (EN).....                       | -0.3V to 15V   |
| Adjustable Voltage (ADJ).....                  | -0.3V to 3V    |
| ByPass Voltage (BYP).....                      | -0.3V to 3V    |
| Storage Temperature Range.....                 | -65°C to 150°C |
| Lead Temperature.....                          | 260°C          |
| Junction Temperature.....                      | 125°C          |

### Recommended Operating Conditions <sup>(2)</sup>

|                                    |                |
|------------------------------------|----------------|
| Input Voltage.....                 | 1.5V to 12V    |
| Ambient Operating Temperature..... | -40°C to 125°C |

### Thermal Information

|   |        |
|---|--------|
| 8L SOIC EP $\theta_{JA}$ <sup>(3)</sup> ..... | 45°C/W |
|---|--------|

### Electrical Characteristics

Unless otherwise noted:  $V_{IN}=3.3V$ ,  $V_{OUT}=1.8V$ ,  $C_{IN}=10\mu F$ ,  $C_{OUT}=22\mu F$ ,  $-40^{\circ}C \leq T_A = T_J \leq 85^{\circ}C$ ,  $T_{J(Max.)} = 125^{\circ}C$ , Typical values are  $T_A = 25^{\circ}C$

| Parameter                   | Symbol                         | Conditions   | Min.             | Typ.  | Max.  | Units        |
|-----------------------------|--------------------------------|--|------------------|-------|-------|--------------|
| Output Voltage Accuracy     | $V_{OUT}$                      |  | -3               |       | 3     | %            |
| Adjustable Voltage          | $V_{ADJ}$                      |  | 0.588            | 0.600 | 0.612 | V            |
| Adjustable bias current     | $I_{ADJ\_Bias}$                |  |                  | 10    | 100   | nA           |
| Maximum Output Current      | $I_{OUT\_Max}$                 |  | 700              |       |       | mA           |
| Load Regulation             |                                | $I_{OUT} = 0 - 700mA$  |                  | 0.6   |       | %            |
| Line Regulation             |                                | $V_{IN}=3.0 - 12V$ ; $I_{OUT}=100mA$                           |                  | 0.15  |       | %            |
| Supply Current              | $I_{SUP}$                      | $V_{IN}=3.3V$ , $I_o=0A$                                       |                  | 120   | 150   | $\mu A$      |
| Shutdown Current            | $I_{SHDN}$                     | $V_{IN}=3.3V$ , $V_{EN}=0V$                                    |                  | <1    |       | $\mu A$      |
| Current Limit               | $I_{LIM}$                      |  |                  | 800   |       | mA           |
| Dropout Voltage             | $V_{DO}$                       | $I_{OUT}=100mA$ ; $V_{OUT}=95\%$ of $V_{OUT(NOM)}$             |                  | 220   |       | mV           |
|                             |                                | $I_{OUT}=250mA$ ; $V_{OUT}=95\%$ of $V_{OUT(NOM)}$             |                  | 300   |       |              |
|                             |                                | $I_{OUT}=500mA$ ; $V_{OUT}=95\%$ of $V_{OUT(NOM)}$             |                  | 425   |       |              |
|                             |                                | $I_{OUT}=750mA$ ; $V_{OUT}=95\%$ of $V_{OUT(NOM)}$             |                  | 600   |       |              |
| PSRR                        | $\Delta V_{OUT}/\Delta V_{IN}$ | $F=10KHz$ $I_o=20mA$   |                  | 33    |       | dB           |
| Output Noise Voltage        | $e_n$                          | BW: 100Hz–100 KHz<br>$C_{OUT} = 22\mu F$<br>$I_{LOAD} = 150mA$ | No $C_{BYP}$     |       | 118   | $\mu V(rms)$ |
|                             |                                |  | $C_{BYP} = 10nF$ |       | 33    |              |
| Enable Threshold Low        | $V_{EN(L)}$                    |  |                  | 1     |       | V            |
| Enable Threshold High       | $V_{EN(H)}$                    |  |                  | 1.1   |       | V            |
| Input Enable Low Current    | $I_{EN(L)}$                    | $V_{EN} = 0V$  |                  | 0     | 10    | nA           |
| Input Enable High Current   | $I_{EN(H)}$                    | $V_{EN} = 1.5V$  |                  | 150   | 300   | nA           |
| Thermal Shutdown            | $T_{SD}$                       |  |                  | 145   |       | $^{\circ}C$  |
| Thermal Shutdown Hysteresis | $T_{SD\_HYS}$                  |  |                  | 15    |       | $^{\circ}C$  |

#### Notes:

1. Stresses above those listed in Absolute Maximum Ratings may cause permanent damage to the device.
2. Measured on approximately 1" square of 1 oz. copper.
3. The total power dissipation for SO-8 EDP package is recommended to 2.5W rated at 25°C ambient temperature. The thermal resistance Junction to Case is 45°C/W. Total power dissipation for the switching regulator and the LDO should be taken in consideration when calculating the output current capability of each regulator

## Micropower 700mA Low Noise Fast Transient Response LDO

Typical Performance Characteristics ( $T_A = 25^\circ\text{C}$  unless otherwise specified)

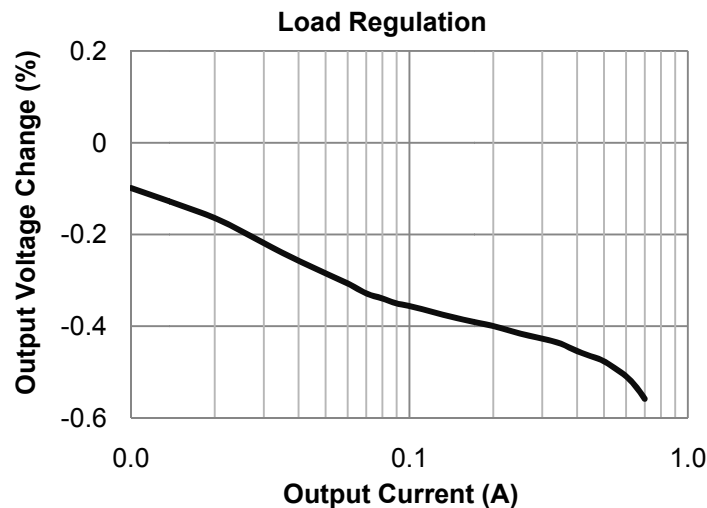
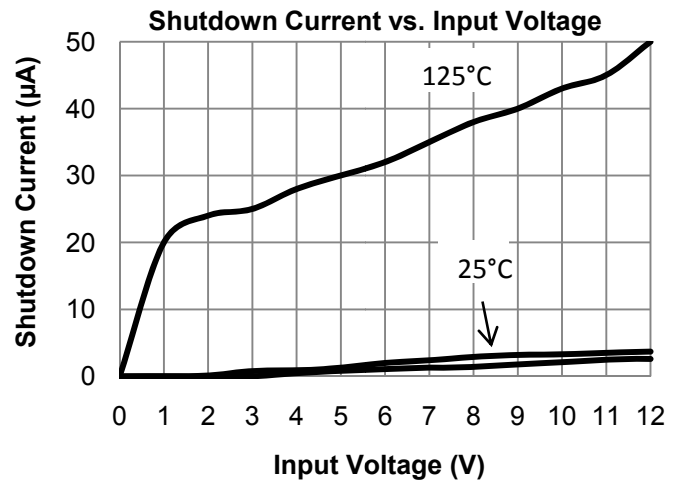
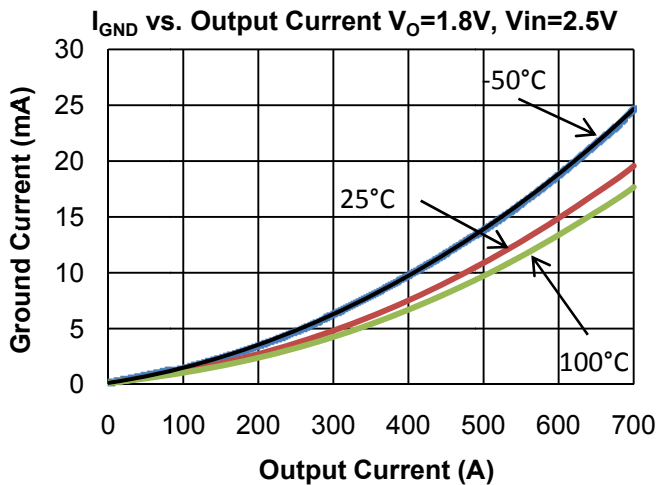
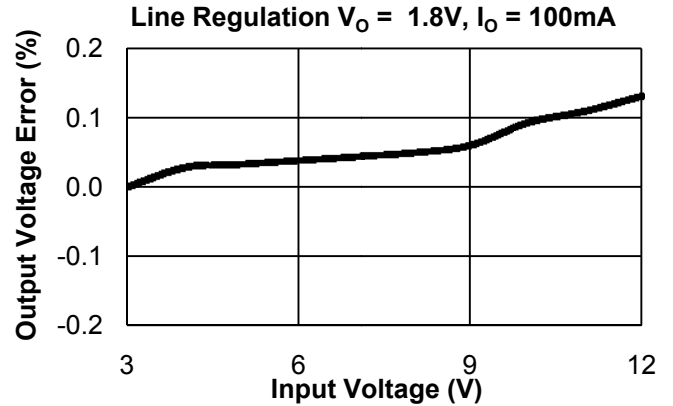
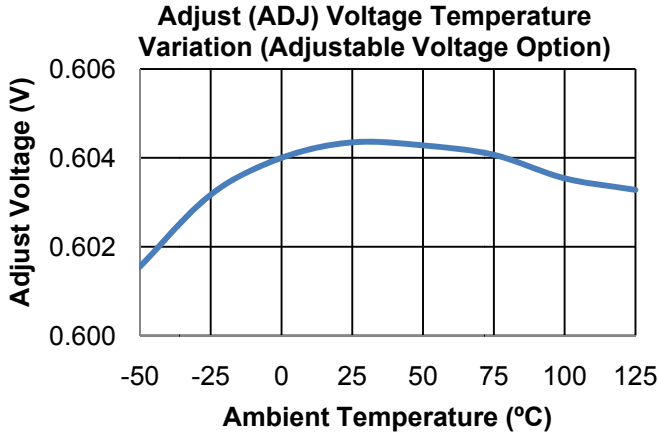

## Micropower 700mA Low Noise Fast Transient Response LDO

Typical Performance Characteristics ( $T_A = 25^\circ\text{C}$  unless otherwise specified)

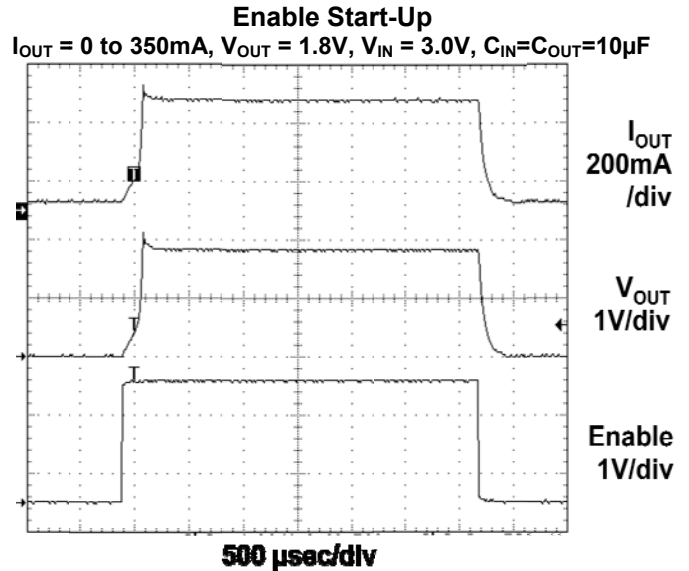
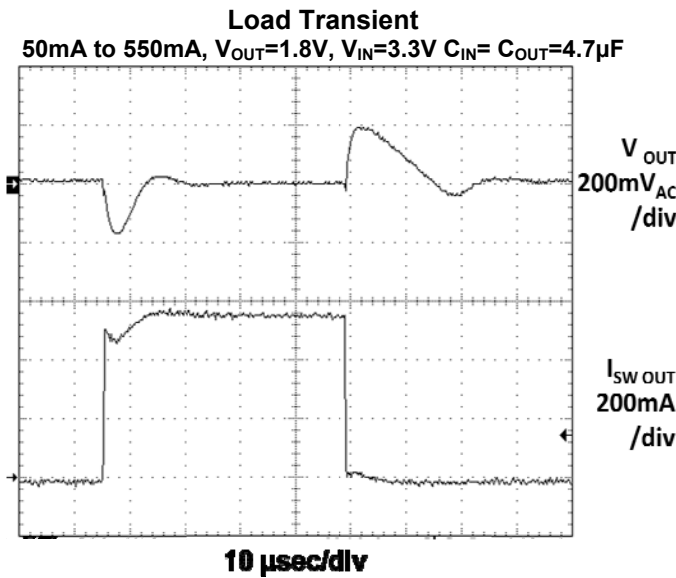
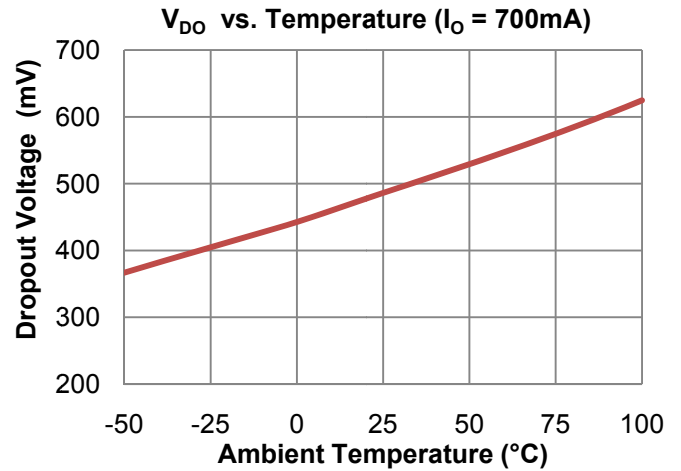
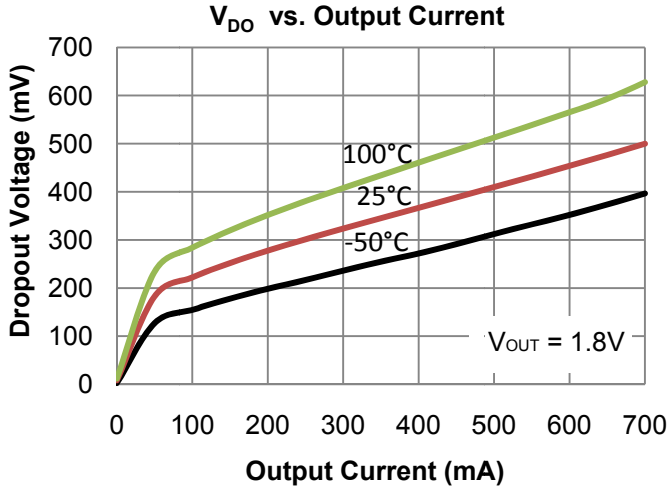

## Micropower 700mA Low Noise Fast Transient Response LDO

### Functional Block Diagram

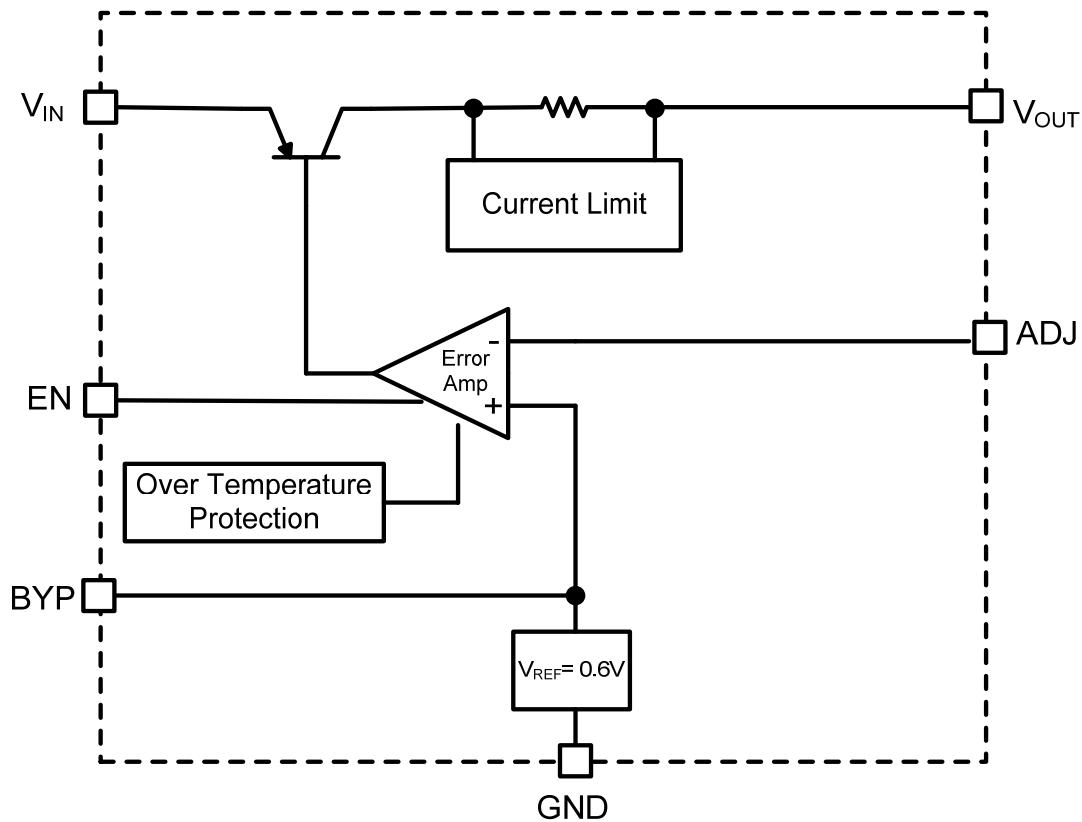

Figure 1: Block Diagram of AMS 3109

## Micropower 700mA Low Noise Fast Transient Response LDO

### Device Summary

The AMS3109 is a high voltage low drop out linear regulator with a current capability of up to 700mA. The LDO has an input voltage range of 1.5V to 12V with an output voltage as low as 0.6V and is stable with a wide range of ceramic, tantalum, and electrolytic output capacitors.

### Shutdown/Enable

The enable (on/off) input threshold voltage is 1.1V. When disabled the LDO quiescent current decreases to a typical value of <math><1\mu\text{A}</math>.

### Fault Protection

Short circuit and over-temperature shutdown disable the converter and LDO in the event of an overload condition. Overtemp shutdown disables the device when the junction temperature exceeds 145 °C. The output current is internally limited to 800mA.

### Input Capacitor

An input bypass capacitor ranging from 1μF to 10μF is required. The capacitor should be placed as close as possible to the device and not be placed more than 1 inch from the LDO.

### Output Capacitor

The output capacitor requirements range from the minimum value required to guarantee stability to a larger value required to meet the extreme transient response requirements. Values range from 10 to 22μF X5R ceramic capacitors. Due to the extreme voltage coefficient of X5R ceramic capacitors, the voltage rating should be at least double the maximum applied voltage.

### Bypass Capacitor

Whether the LDO is configured to be in a fixed or adjustable voltage configuration, connecting a capacitor between the ByPass (BYP) pin and ground can significantly reduce output noise. Values can range from 0pF to 10nF, depending on the sensitivity to output noise in the application. The start-up speed of the AMS3109 is inversely proportional to the size of the bypass capacitor. Applications requiring a slow ramp-up of output voltage should consider larger values of bypass capacitance. Likewise, if rapid turn-on is necessary, consider omitting  $C_{\text{BYP}}$ .

Because the ByPass (BYP) pin is high-impedance, careful considering must be taken in the PCB layout to minimize noise pickup, and capacitors must be selected to minimize current leakage. Current leakage into the BYP pin will directly affect the regulator's accuracy and should be kept low as possible. Using high quality ceramic and film types capacitors are recommended for their low leakage characteristics.

### Adjustable Feedback Resistor Selection

AMS 3109 uses a 0.6V reference voltage at the positive terminal of the error amplifier. To set the output voltage a programming resistor from the adjust pin (ADJ) to ground must be selected (See Pg.1). A 10kΩ resistor is a good selection for a programming resistor R2. A higher value may result in an excessively sensitive feedback node while a lower value will draw more current and degrade the light load efficiency. The equation for selecting the voltage specific resistor is:

$$R1 = \left(\frac{V_{\text{out}}}{V_{\text{ref}}}-1\right) \cdot R2 = \left(\frac{1.8\text{V}}{0.6\text{V}}-1\right) \cdot 10\text{k}\Omega = 20\text{k}\Omega$$

**Table 1: Adjustable Feedback Resistor values**

| $V_{\text{OUT}}$ (V) | R1 (kΩ)<br>(R2=10kΩ) |
|----------------------|----------------------|
| 1.8                  | 20.0                 |
| 2.5                  | 31.6                 |
| 3.3                  | 45.3                 |
| 5.0                  | 73.2                 |

### PCB Layout

The following guidelines should be followed to insure proper layout.

1.  $V_{\text{IN}}$  Capacitor. A low ESR ceramic bypass capacitor must be placed as close to the IC as possible.
2. Adjustable (ADJ) Feedback Resistors. The adjustable feedback resistors should be placed as close as possible the IC. Minimize the length of the trace from the feedback pin to the resistors. This is a high impedance node susceptible to interference from external RF noise sources.
3. Ground.
4. For good thermal performance vias are required to couple the exposed tab of the SO-8 package to the PCB ground plane. The via diameter should be 0.3mm to 0.33mm positioned on a 1.2mm grid.

---

## Micropower 700mA Low Noise Fast Transient Response LDO

### Output Power and Thermal Limits

The AMS3109 junction temperature and current capability depends on the internal dissipation and the junction to case thermal resistance of the SO-8 exposed paddle package.

Additionally, the paddle and PCB temperature will be elevated due to the total losses of the LDO and of other circuits mounted to the PCB.

$$T_{jmax} = P_d \cdot \theta_{jc} + T_{pcb} + T_{amb}$$

The internal losses contribute to the junction temperature rise above the paddle and PCB temperature.



## Micropower 700mA Low Noise Fast Transient Response LDO

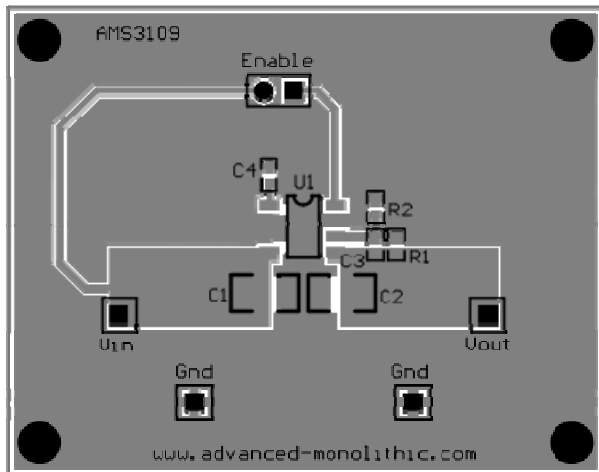

Figure 2: AMS3109 Evaluation Board Top Side

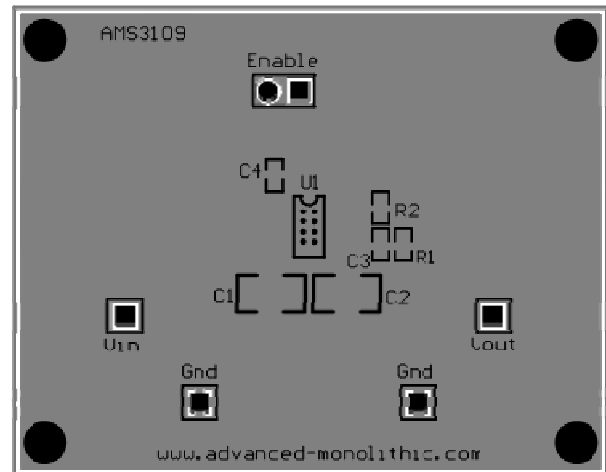

Figure 3: AMS3109 Evaluation Board Bottom Side

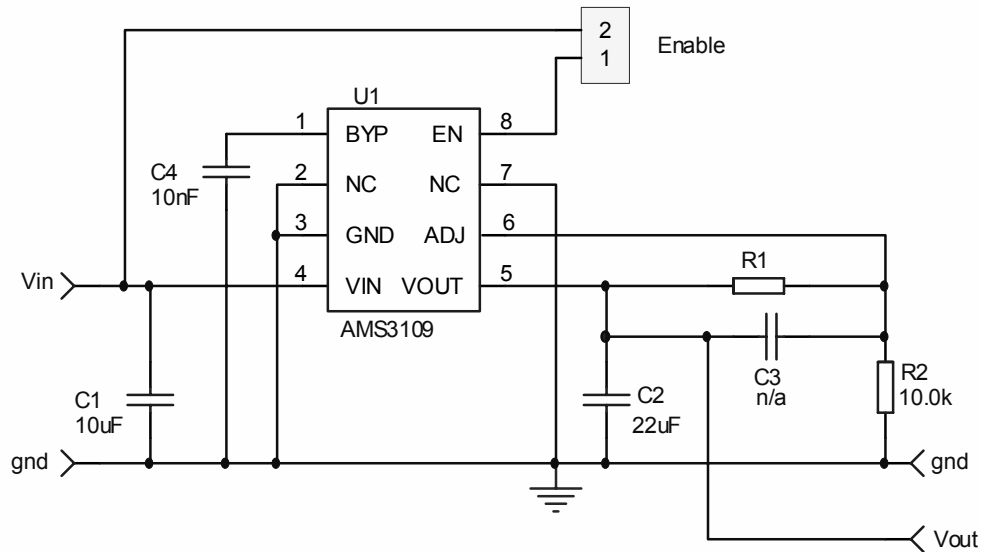

Figure 4: AMS3109 Evaluation Board Schematic

Table 2: AMS3109 Evaluation Board Bill of Materials

| Component | Value                               | Manufacturer                   | Manufacturer Part Number |                  |
|-----------|-------------------------------------|--------------------------------|--------------------------|------------------|
| C1        | 10 $\mu$ F, 50V, X5R, 1210, Ceramic | Taiyo Yuden                    | UMK325BJ106KM-T          |                  |
| C2        | 22 $\mu$ F, 10V, X5R, 0805, Ceramic | Taiyo Yuden                    | LMK212BJ226MG-T          |                  |
| C3        | Optional Feedforward                |                                |                          |                  |
| C4        | 10nF, 50V,20%,X7R,0603              | Murata                         | GRM188R71H103MA01        |                  |
| R1        | 1.2V                                | 10.0k $\Omega$ , 0.1W, 0603 1% | Various                  | CRCW0603xxKxFKEA |
|           | 1.8V                                | 20.0k $\Omega$ , 0.1W, 0603 1% | Various                  | CRCW0603xxKxFKEA |
|           | 2.5V                                | 31.6k $\Omega$ , 0.1W, 0603 1% | Various                  | CRCW0603xxKxFKEA |
|           | 3.3V                                | 45.3k $\Omega$ , 0.1W, 0603 1% | Various                  | CRCW0603xxKxFKEA |
|           | 5.0V                                | 73.2k $\Omega$ , 0.1W, 0603 1% | Various                  | CRCW0603xxKxFKEA |
| R2        | 10.0k $\Omega$ , 0.1W, 0603 1%      | Various                        | CRCW060310K0FKEA         |                  |
| U1        | Linear Regulator                    | AMS                            | AMS3109 SOIC-8 EDP       |                  |

## Micropower 700mA Low Noise Fast Transient Response LDO

### Ordering Information

| Device                     | Package    |
|----------------------------|------------|
| AMS3109S <sup>(1)(2)</sup> | SOIC-8 EDP |

Notes:

1. Available in tape and reel only. A reel contains 2,500 devices.
2. Available in lead-free package only. Device is fully WEEE and RoHS compliant

### Outline Drawing and Landing Pattern

SOIC-8 package dimensions are inches (millimeters) unless otherwise noted.

