



TAI-SAW TECHNOLOGY CO., LTD.

No. 3, Industrial 2nd Rd., Ping-Chen Industrial District,
Taoyuan, 324, Taiwan, R.O.C.

TEL: 886-3-4690038 FAX: 886-3-4697532

E-mail: tstsales@mail.taisaw.com Web: www.taisaw.com

Product Specifications Approval Sheet

Product Description: 810 MHz 0.3MHz BW SMD 3.8 x 3.8 mm SAW IF Filter

TST Parts No.: TB1118A

Customer Parts No.: _____

Customer signature required
Company: _____
Division: _____
Approved by : _____
Date: _____

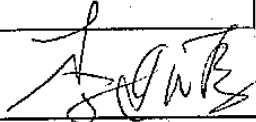
Checked by: _____ Kazuma Lee 

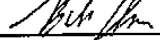
Approval by: _____ Bob Chau 

Date: _____ 10 / 17 / 2013

1. Customer signed back is required before TST can proceed with sample build and receive orders.
2. Orders received without customer signed back will be regarded as agreement on the specifications.
3. Any specifications changes must be approved upon by both parties and a new revision of specifications shall be released to reflect the changes.



TAI-SAW TECHNOLOGY CO., LTD.

No.3, Industrial 2nd Rd., Ping-Chen Industrial District, Taoyuan, Taiwan, R.O.C.

TEL: 886-3-4690038 FAX: 886-3-4697532

E-mail: tstsales3@mail.taisaw.com Web: www.taisaw.com

SAW Filter 810MHz 0.3MHz BW (SMD 3.8x3.8 mm)

MODEL NO.: TB1118A

REV. NO.1

A. MAXIMUM RATING:

1. Operating temperature range: -43°C to 85°C
2. Storage temperature range: -45°C to 85°C
3. Input Power Level : 25 dBm
4. Maximum DC Voltage : 10V

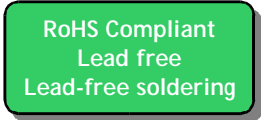

Electrostatic Sensitive Device

B. Characteristics :

1. Ambient Temperature: 25 °C

Item	Unit	Min.	Type.	Max.
Center frequency, F_c	MHz	-	810	-
Insertion Loss, IL	dB	-	5.0	9.0
-1dB bandwidth	KHz	-	395	-
-3dB bandwidth	MHz	-	0.57	-
-12dB bandwidth	MHz	-	0.92	1.10
-40dB bandwidth	MHz	-	1.86	2.00
Passband Ripple F _c +/- 80KHz	dB	-	0.2	3.0
Attenuation:(Reference level from 0dB)				
DC ~ 808MHz	dB	40	45	
812MHz ~ 812.5MHz	dB	38	41	
812MHz ~ 1500MHz	dB	40	45	
Temperature Coefficient	ppm/°C ²	-	-0.036	-
Source Impedance	Ohm	-	50	-
Load Impedance	Ohm	-	50	-

C. Frequency Characteristics :

(1) Wide band Response:(span 10MHz)

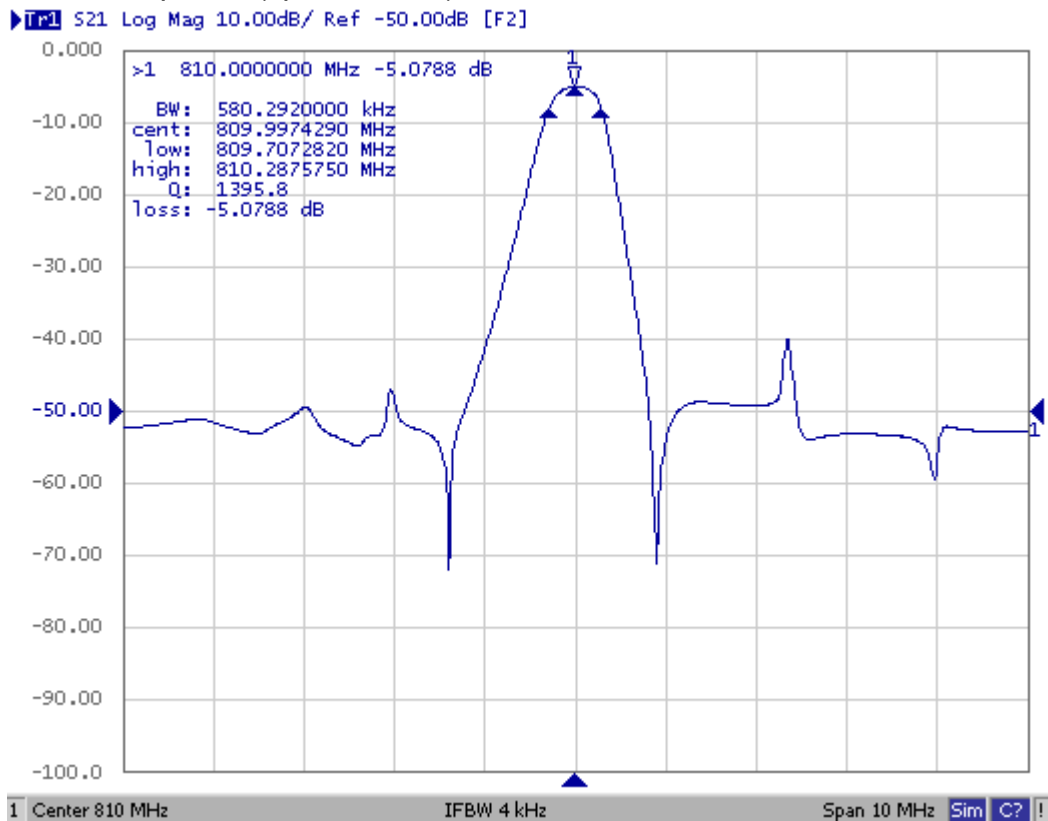

Fig1. Horizontal: 1MHz/Div Vertical: 10dB/Div

(2) Pass band Response and Group Time Delay response:

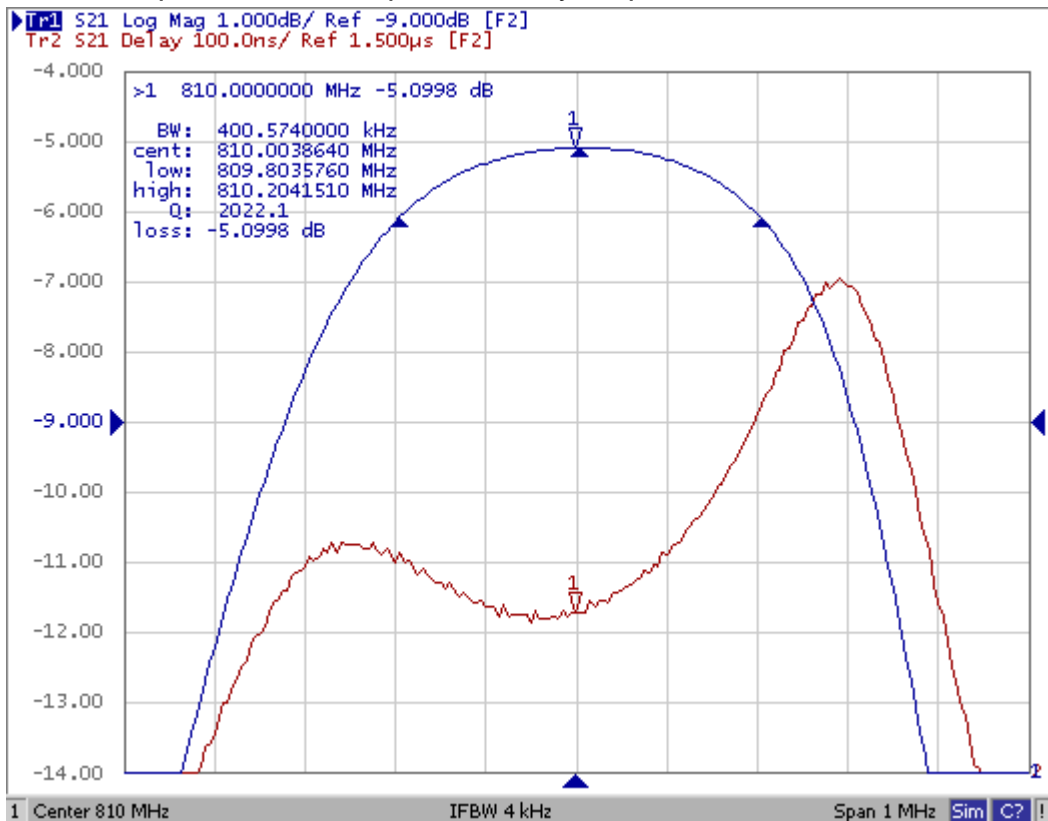
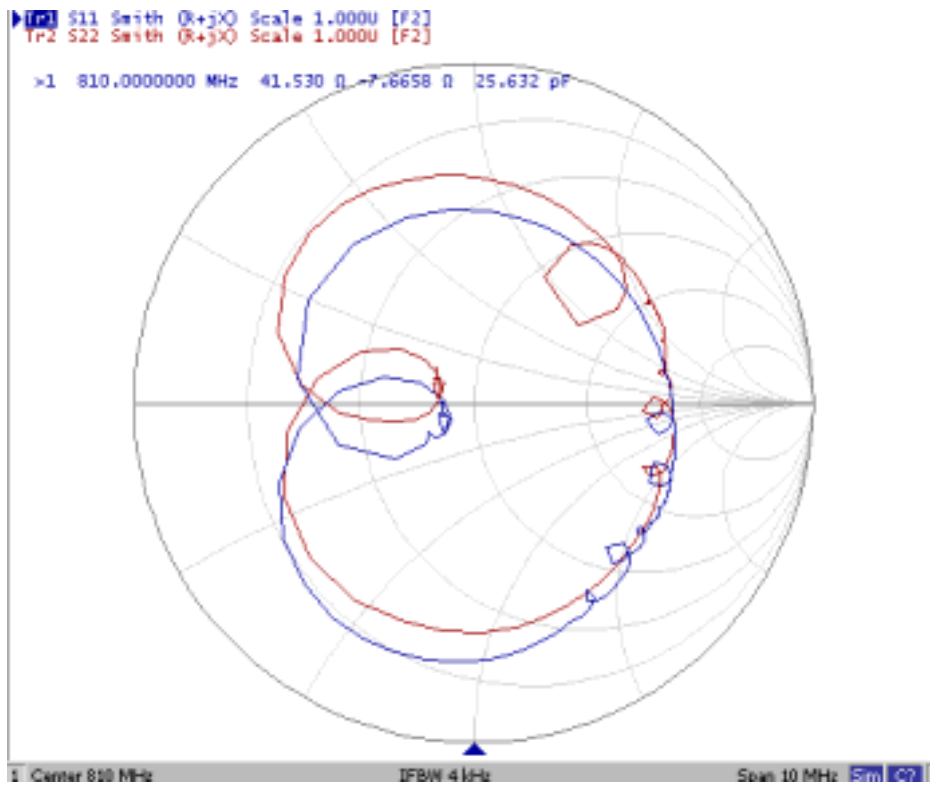

Fig2. Horizontal: 0.1MHz/Div Vertical: 1dB/Div

Vertical: 100ns/Div

(3) Smith Chart:



D. Matching Circuit:

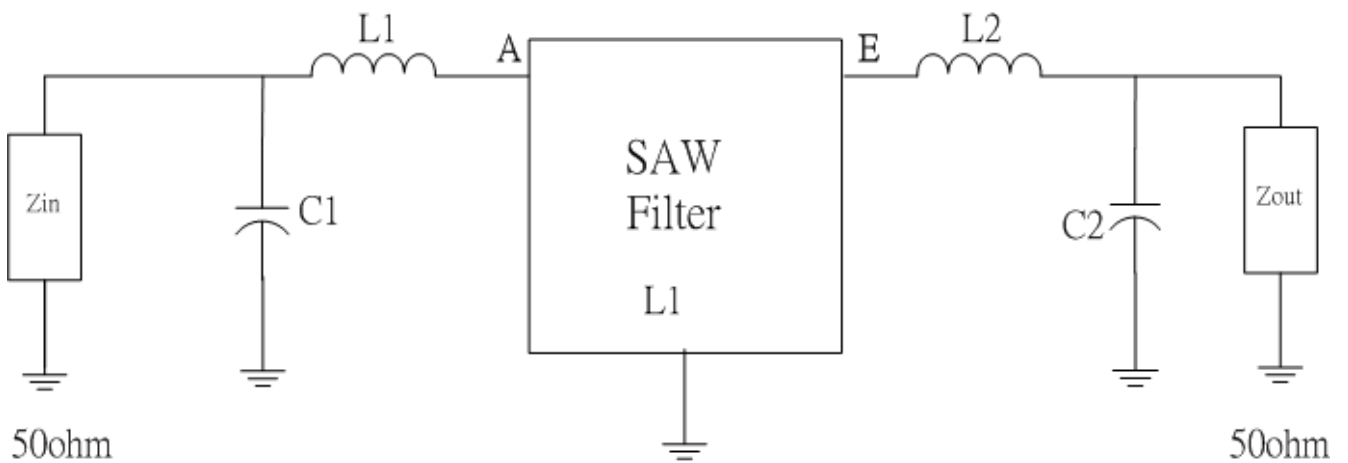

L1=18nH L2=18nH C1=5.6pF C2=5.6pF

E. Outline Drawing:

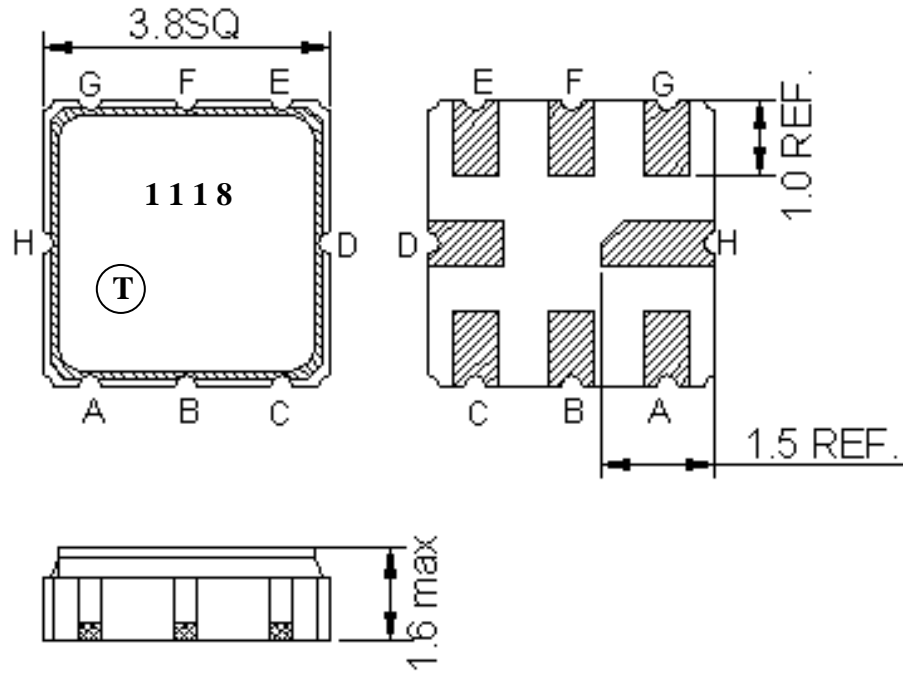

- Pin A – RF input
- Pin E – RF output
- Pin B, C, D, F, G, H – To Be Ground

: Week Code

Unit : mm

: Product / Year Code

Year	2013 2017	2014 2018	2015 2019	2016 2020
Product Code	B	b	B	b

Week Code Table

WK01	WK02	WK03	WK04	WK05	WK06	WK07	WK08	WK09	WK10	WK11	WK12	WK13
A	B	C	D	E	F	G	H	I	J	K	L	M
WK14	WK15	WK16	WK17	WK18	WK19	WK20	WK21	WK22	WK23	WK24	WK25	WK26
N	O	P	Q	R	S	T	U	V	W	X	Y	Z
WK27	WK28	WK29	WK30	WK31	WK32	WK33	WK34	WK35	WK36	WK37	WK38	WK39
a	b	c	d	e	f	g	h	i	j	k	l	m
WK40	WK41	WK42	WK43	WK44	WK45	WK46	WK47	WK48	WK49	WK50	WK51	WK52
n	o	p	q	r	s	t	u	v	w	x	y	z

H. RECOMMENDED REFLOW PROFILE:

