



# 12N70

Power MOSFET

## 12A, 700V N-CHANNEL POWER MOSFET

### DESCRIPTION

The UTC **12N70** are N-Channel enhancement mode power MOSFET which are produced using UTC's proprietary, planar stripe, DMOS technology.

These devices are suited for high efficiency switch mode power supply. To minimize on-state resistance, provide superior switching performance, and withstand high energy pulse in the avalanche and commutation mode the advanced technology has been especially tailored.

### FEATURES

- \*  $R_{DS(ON)} < 1.0\Omega @ V_{GS} = 10V$
- \* Fast switching capability
- \* Avalanche energy specified
- \* Improved dv/dt capability, high ruggedness

### SYMBOL

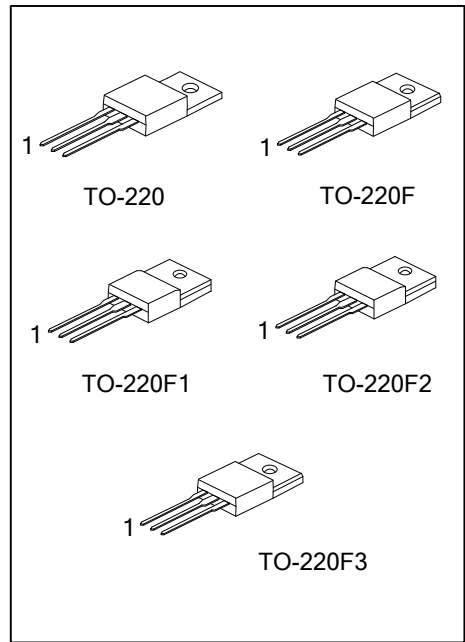
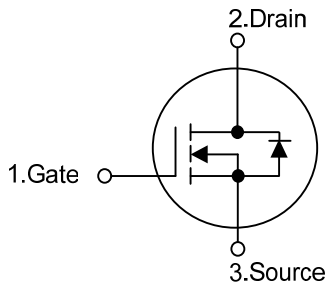

■ ORDERING INFORMATION

Ordering Number		Package	Pin Assignment			Packing
Lead Free	Halogen Free		1	2	3	
12N70L-TA3-T	12N70G-TA3-T	TO-220	G	D	S	Tube
12N70L-TF3-T	12N70G-TF3-T	TO-220F	G	D	S	Tube
12N70L-TF1-T	12N70G-TF1-T	TO-220F1	G	D	S	Tube
12N70L-TF2-T	12N70G-TF2-T	TO-220F2	G	D	S	Tube
12N70L-TF3T-T	12N70G-TF3T-T	TO-220F3	G	D	S	Tube

Note: Pin Assignment: G: Gate D: Drain S: Source

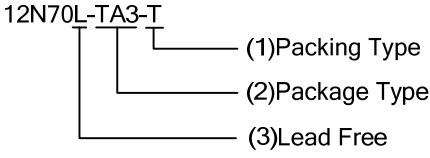
<p>12N70L-TA3-T</p>  <p>(1) Packing Type (2) Package Type (3) Lead Free</p>	<p>(1) T: Tube (2) TA3: TO-220, TF3: TO-220F, TF1: TO220-F1, TF2: TO-220F2, TF3T: TO-220F3 (3) L: Lead Free, G: Halogen Free</p>
----------------------------------------------------------------------------------------------------------------------------------------------------------------------	------------------------------------------------------------------------------------------------------------------------------------------

■ MARKING INFORMATION

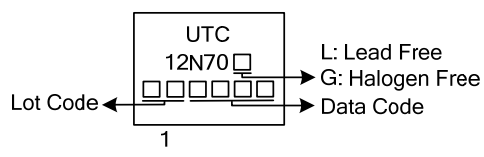
PACKAGE	MARKING
TO-220 TO-220F TO-220F1 TO-220F2 TO-220F3	 <p>UTC 12N70 Lot Code → [ ][ ][ ][ ] → Data Code 1</p> <p>L: Lead Free G: Halogen Free</p>

■ ABSOLUTE MAXIMUM RATINGS ( $T_C = 25^\circ\text{C}$ , unless otherwise specified)

PARAMETER		SYMBOL	RATINGS	UNIT
Drain-Source Voltage		$V_{DSS}$	700	V
Gate-Source Voltage		$V_{GSS}$	$\pm 30$	V
Avalanche Current (Note 2)		$I_{AR}$	12	A
Drain Current	Continuous	$I_D$	12	A
	Pulsed (Note 2)	$I_{DM}$	48	A
Avalanche Energy	Single Pulsed (Note 3)	$E_{AS}$	790	mJ
	Repetitive (Note 2)	$E_{AR}$	24	mJ
Peak Diode Recovery dv/dt (Note 4)		dv/dt	4.5	V/ns
Power Dissipation	TO-220	$P_D$	225	$^\circ\text{C/W}$
	TO-220F/TO-220F1		52	$^\circ\text{C/W}$
	TO-220F3		55	$^\circ\text{C/W}$
	TO-220F2			
Junction Temperature		$T_J$	+150	$^\circ\text{C}$
Operating Temperature		$T_{OPR}$	-55 ~ +150	$^\circ\text{C}$
Storage Temperature		$T_{STG}$	-55 ~ +150	$^\circ\text{C}$

- Notes: 1. Absolute maximum ratings are those values beyond which the device could be permanently damaged. Absolute maximum ratings are stress ratings only and functional device operation is not implied.  
 2. Repetitive Rating: Pulse width limited by maximum junction temperature  
 3.  $L=10\text{mH}$ ,  $I_{AS}=12\text{A}$ ,  $V_{DD}=50\text{V}$ ,  $R_G=25\Omega$ , Starting  $T_J=25^\circ\text{C}$   
 4.  $I_{SD} \leq 12\text{A}$ ,  $di/dt \leq 200\text{A}/\mu\text{s}$ ,  $V_{DD} \leq BV_{DSS}$ , Starting  $T_J=25^\circ\text{C}$

■ THERMAL DATA

PARAMETER		SYMBOL	RATING	UNIT
Junction to Ambient		$\theta_{JA}$	62.5	$^\circ\text{C/W}$
Junction to Case	TO-220	$\theta_{JC}$	0.56	$^\circ\text{C/W}$
	TO-220F/TO-220F1		2.40	$^\circ\text{C/W}$
	TO-220F3			
	TO-220F2		2.27	$^\circ\text{C/W}$

■ ELECTRICAL CHARACTERISTICS (T<sub>C</sub> = 25°C, unless otherwise specified)

PARAMETER	SYMBOL	TEST CONDITIONS	MIN	TYP	MAX	UNIT
<b>OFF CHARACTERISTICS</b>						
Drain-Source Breakdown Voltage	BV <sub>DSS</sub>	V <sub>GS</sub> = 0 V, I <sub>D</sub> = 250 μA	700			V
Drain-Source Leakage Current	I <sub>DSS</sub>	V <sub>DS</sub> = 700 V, V <sub>GS</sub> = 0 V			10	μA
Gate-Source Leakage Current	I <sub>GSS</sub>	V <sub>GS</sub> = ±30 V, V <sub>DS</sub> = 0 V			±100	nA
Breakdown Voltage Temperature Coefficient	ΔBV <sub>DSS</sub> /ΔT <sub>J</sub>	I <sub>D</sub> = 250 μA, Referenced to 25°C		0.7		V/°C
<b>ON CHARACTERISTICS</b>						
Gate Threshold Voltage	V <sub>GS(TH)</sub>	V <sub>DS</sub> = V <sub>GS</sub> , I <sub>D</sub> = 250 μA	2.0		4.0	V
Static Drain-Source On-State Resistance	R <sub>DS(ON)</sub>	V <sub>GS</sub> = 10V, I <sub>D</sub> = 6.0A		0.7	1.0	Ω
<b>DYNAMIC CHARACTERISTICS</b>						
Input Capacitance	C <sub>ISS</sub>	V <sub>DS</sub> = 25 V, V <sub>GS</sub> = 0 V, f = 1MHz		1600	1900	pF
Output Capacitance	C <sub>OSS</sub>			160	270	pF
Reverse Transfer Capacitance	C <sub>RSS</sub>			25	35	pF
<b>SWITCHING CHARACTERISTICS</b>						
Turn-On Delay Time	t <sub>D(ON)</sub>	V <sub>DD</sub> = 30V, I <sub>D</sub> = 0.5A, R <sub>G</sub> = 25Ω (Note 1, 2)		96	120	ns
Turn-On Rise Time	t <sub>R</sub>			158	240	ns
Turn-Off Delay Time	t <sub>D(OFF)</sub>			370	400	ns
Turn-Off Fall Time	t <sub>F</sub>			180	220	ns
Total Gate Charge	Q <sub>G</sub>	V <sub>DS</sub> = 50V, I <sub>D</sub> = 1.3A, V <sub>GS</sub> = 10 V (Note 1, 2)		56	60	nC
Gate-Source Charge	Q <sub>GS</sub>			10		nC
Gate-Drain Charge	Q <sub>GD</sub>			17		nC
<b>SOURCE- DRAIN DIODE RATINGS AND CHARACTERISTICS</b>						
Drain-Source Diode Forward Voltage	V <sub>SD</sub>	V <sub>GS</sub> = 0 V, I <sub>S</sub> = 12A			1.4	V
Maximum Continuous Drain-Source Diode Forward Current	I <sub>S</sub>				12	A
Maximum Pulsed Drain-Source Diode Forward Current	I <sub>SM</sub>				48	A
Reverse Recovery Time	t <sub>rr</sub>	V <sub>GS</sub> = 0 V, I <sub>S</sub> = 12A, dI <sub>F</sub> /dt = 100 A/μs (Note 1)		380		ns
Reverse Recovery Charge	Q <sub>RR</sub>			3.5		μC

Notes: 1. Pulse Test: Pulse width ≤ 300 μs, Duty cycle ≤ 2%

2. Essentially independent of operating temperature

■ TEST CIRCUITS AND WAVEFORMS

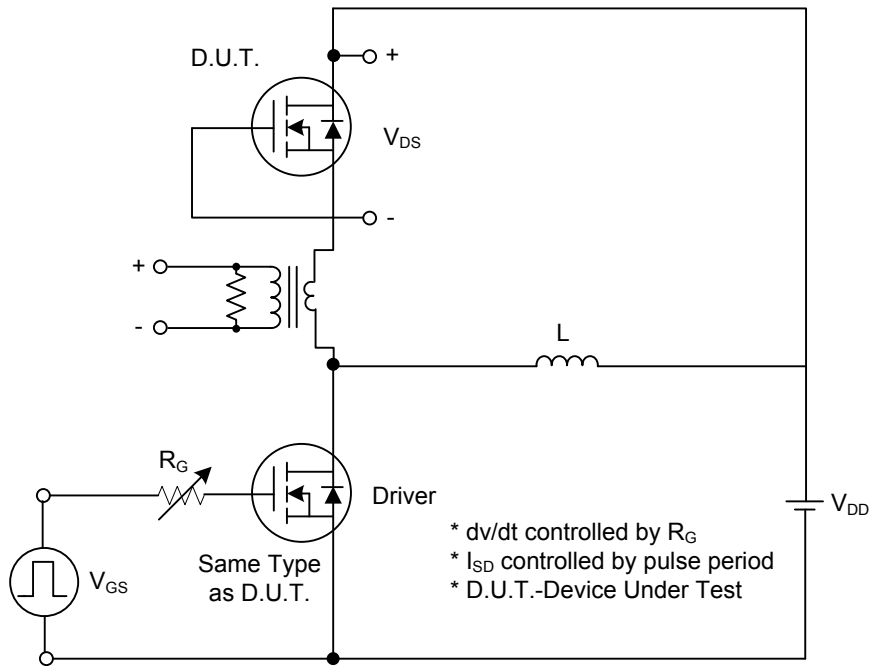

Peak Diode Recovery  $dv/dt$  Test Circuit

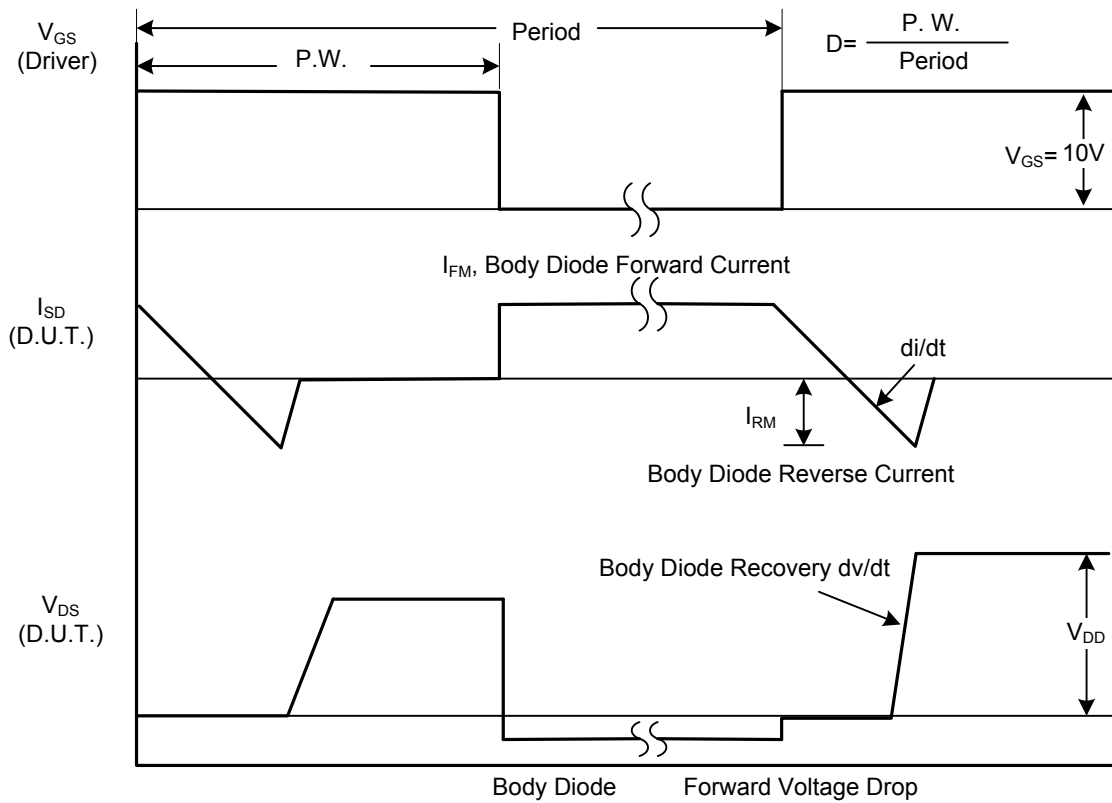

Peak Diode Recovery  $dv/dt$  Waveforms

## TEST CIRCUITS AND WAVEFORMS (Cont.)

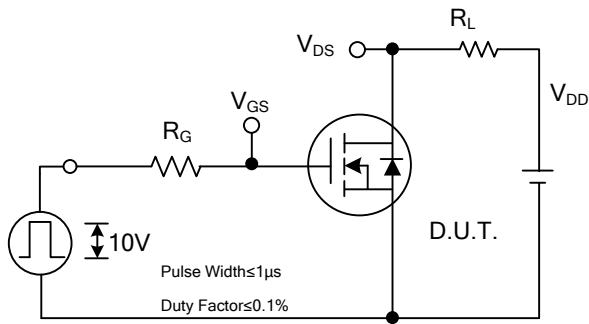

**Switching Test Circuit**

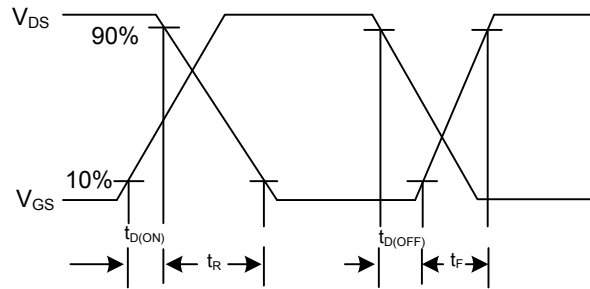

**Switching Waveforms**

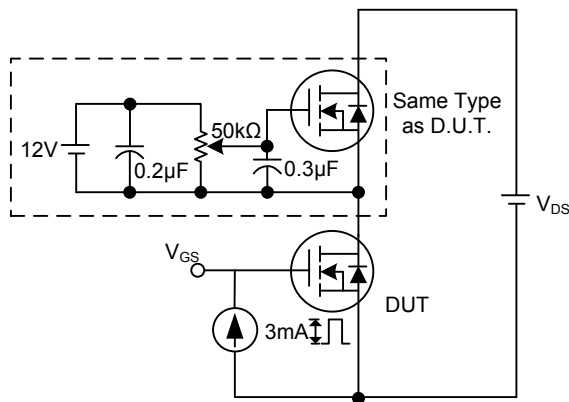

**Gate Charge Test Circuit**

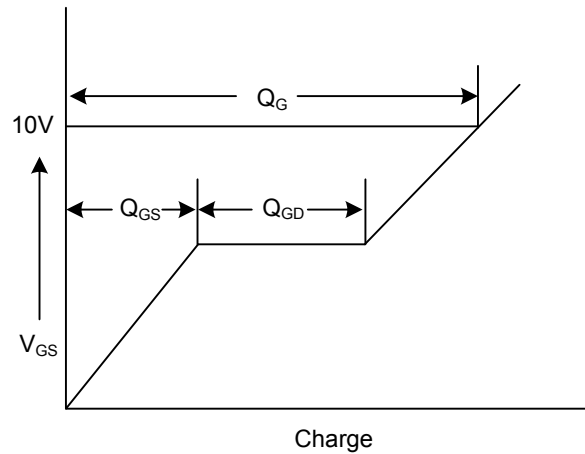

**Gate Charge Waveform**

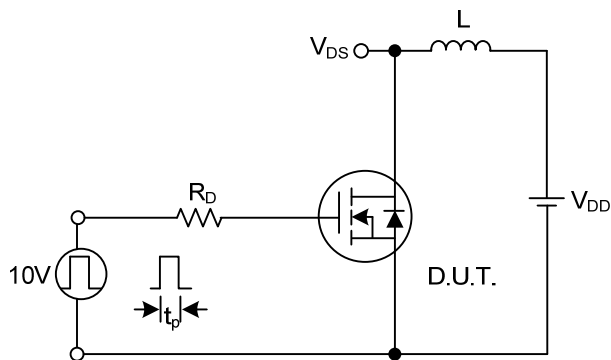

**Unclamped Inductive Switching Test Circuit**

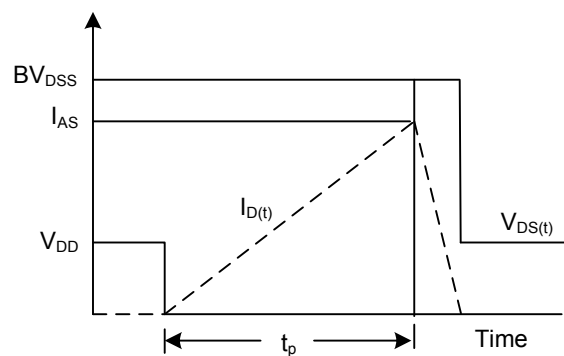

**Unclamped Inductive Switching Waveforms**

## ■ TYPICAL CHARACTERISTICS

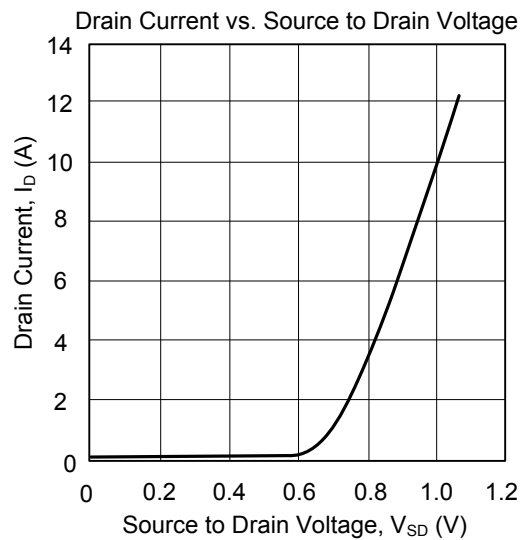
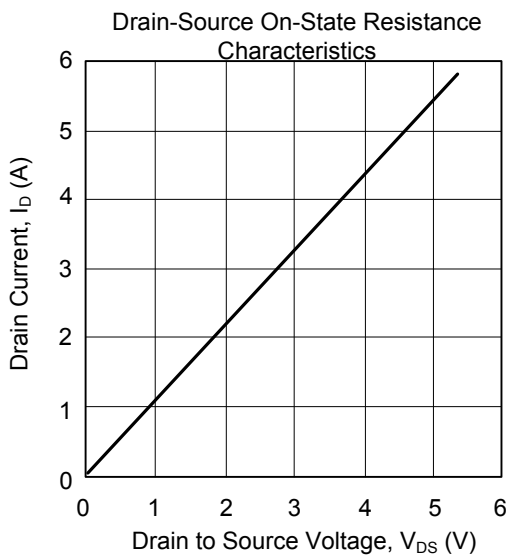
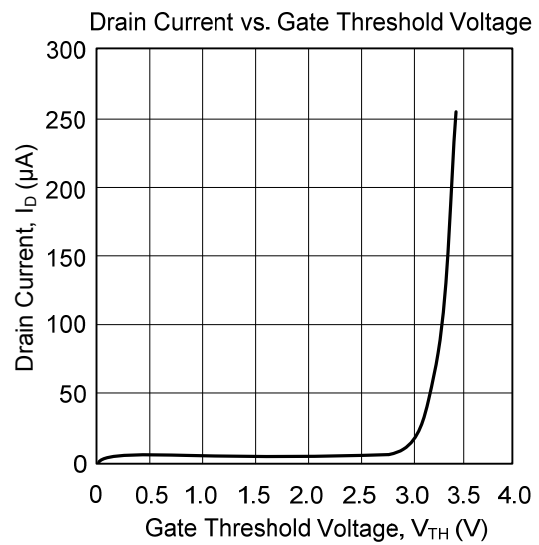
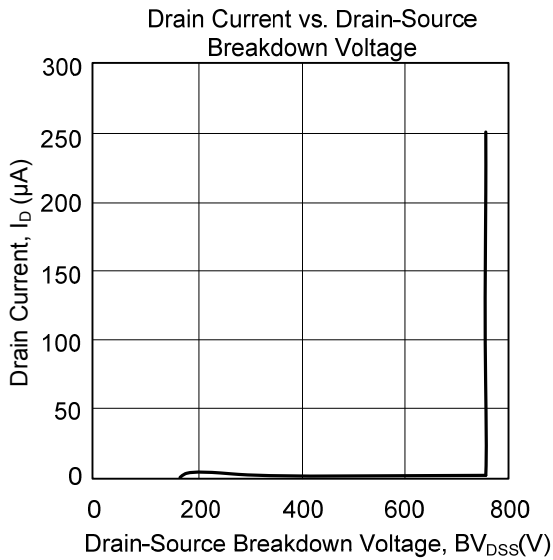

UTC assumes no responsibility for equipment failures that result from using products at values that exceed, even momentarily, rated values (such as maximum ratings, operating condition ranges, or other parameters) listed in products specifications of any and all UTC products described or contained herein. UTC products are not designed for use in life support appliances, devices or systems where malfunction of these products can be reasonably expected to result in personal injury. Reproduction in whole or in part is prohibited without the prior written consent of the copyright owner. The information presented in this document does not form part of any quotation or contract, is believed to be accurate and reliable and may be changed without notice.