

AN3893NFHP

Cylinder Motor Driver IC for Video Camera

Overview

The AN3893NFHP is a cylinder sensorless-motor driver IC for Video Camera.

Features

- Operating voltage range : $V_{CC}=3.2$ to $5.5V$
- Reduction of noise generated at current switching by 3-phase full-wave overlapping drive. Need external power transistors
- Standby mode for reducing power consumption
- Built-in PG and FG amplifiers and waveform shaping circuits
- Switching-regulator control-comparator-output and pre-drive outputs

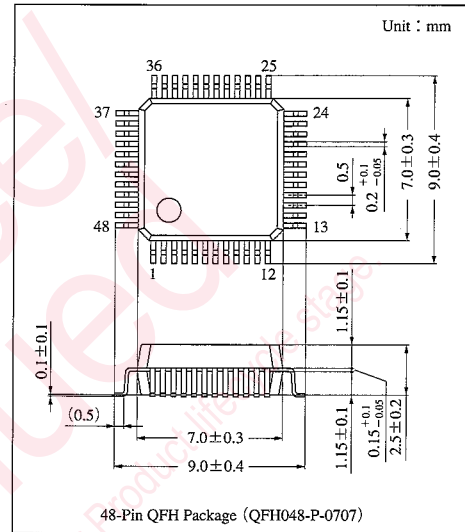

Pin Descriptions

Pin No.	Pin name and Symbol	Pin No.	Pin name and Symbol
1	FG wave-shaped output YFG	25	Motor coil (2) M2
2	FG amplifier output FGout	26	Motor back-EMF input (2) M2D
3	FG input FGin	27	Motor coil (1) M1
4	Ground for FG/PG GP	28	Motor back-EMF input (1) M1D
5	Reference voltage for FG/PG PGref	29	Motor power supply, V _M
6	PG input PGin	30	Conducting-phase adjustment (2) XT
7	PG amplifier output PGout	31	Upper slope voltage SU
8	PG comparator input PGC	32	Lower slope voltage SL
9	Power supply V _{CC}	33	No connection
10	PG wave-shaped output YPG	34	Voltage feedback phase correction PCV
11	Torque command EC	35	Switching regulator control output PCS
12	Torque reference ECR	36	Switching regulator triangle-wave input PC
13	Current sensor CS	37	Switching predrive output SWB
14	Current feedback phase correction PCI	38	Unregulated voltage supply V _B
15	Ground GND	39	No connection
16	Lower predrive output (1) L1	40	Switching regulator ground SWB
17	Lower predrive output (2) L2	41	Clock input CLK
18	Lower predrive output (3) L3	42	Logic ground GD
19	Upper predrive output (3) U3	43	Test mode switching input T1
20	Upper predrive output (2) U2	44	No connection
21	Upper predrive output (1) U1	45	Logic power supply V _{DD}
22	Conducting-phase adjustment (1) XL	46	Starting frequency switching input SFS
23	Motor coil (3) M3	47	Conducting-phase switching input DWS
24	Motor back-EMF input M3D	48	Standby switching input STB

■ Block Diagram

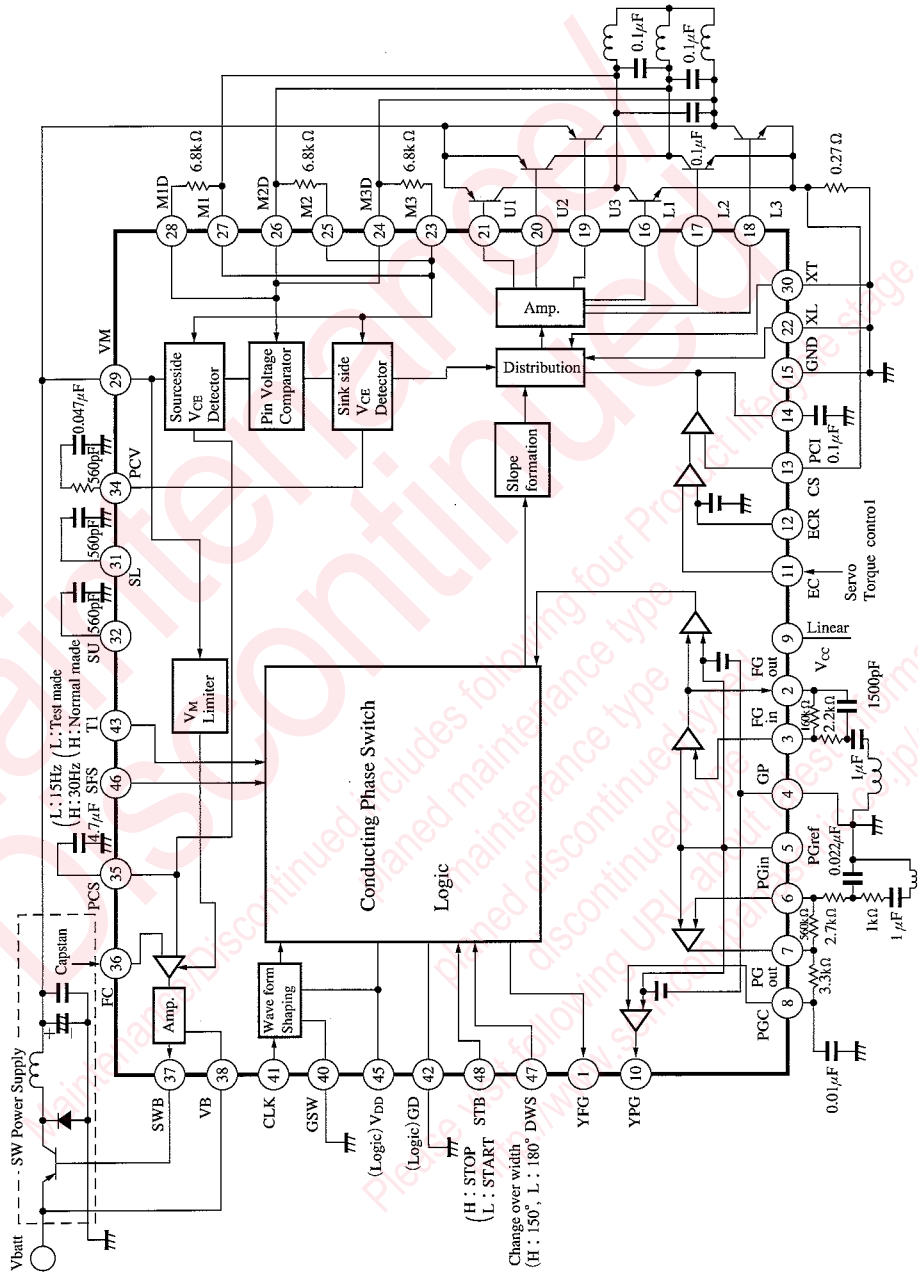

ICs for VCR

■ Absolute Maximum Ratings

Parameter	Symbol	Rating	Unit
Supply voltage	V_{CC}	6.0	V
Motor supply voltage	V_{29}	14.0	V
Output terminal voltage (n=23, 24, 25, 26, 27, 28, 19, 20, 21)	V_n	14.0	V
Unregulated input voltage	V_{38}	14.0	V
Switching regulator drive output terminal voltage	V_{37}	14.0	V
Terminal voltage (n=3, 5, 6, 10, 11, 12, 13, 22, 30, 33, 36, 41, 43, 46, 47, 48)	V_n	-0.3 to $V_{CC}+0.3$	V
Power dissipation	P_D	300	mW
Operating ambient temperature ^{Note 1)}	T_{opr}	-20 to +70	°C
Storage temperature ^{Note 1)}	T_{stg}	-55 to +125	°C

Note 1) $T_a=25^\circ\text{C}$ except operating ambient temperature and storage temperature.

■ Recommended Operating Range ($T_a=25^\circ\text{C}$)

Parameter	Symbol	Range
Operating supply voltage range	V_{CC}	3.2V to 5.5V
Motor supply operating voltage range	V_M	3.0V to 12V

Request for your special attention and precautions in using the technical information and semiconductors described in this book

- (1) If any of the products or technical information described in this book is to be exported or provided to non-residents, the laws and regulations of the exporting country, especially, those with regard to security export control, must be observed.
- (2) The technical information described in this book is intended only to show the main characteristics and application circuit examples of the products. No license is granted in and to any intellectual property right or other right owned by Panasonic Corporation or any other company. Therefore, no responsibility is assumed by our company as to the infringement upon any such right owned by any other company which may arise as a result of the use of technical information described in this book.
- (3) The products described in this book are intended to be used for standard applications or general electronic equipment (such as office equipment, communications equipment, measuring instruments and household appliances).
Consult our sales staff in advance for information on the following applications:
 - Special applications (such as for airplanes, aerospace, automobiles, traffic control equipment, combustion equipment, life support systems and safety devices) in which exceptional quality and reliability are required, or if the failure or malfunction of the products may directly jeopardize life or harm the human body.
 - Any applications other than the standard applications intended.
- (4) The products and product specifications described in this book are subject to change without notice for modification and/or improvement. At the final stage of your design, purchasing, or use of the products, therefore, ask for the most up-to-date Product Standards in advance to make sure that the latest specifications satisfy your requirements.
- (5) When designing your equipment, comply with the range of absolute maximum rating and the guaranteed operating conditions (operating power supply voltage and operating environment etc.). Especially, please be careful not to exceed the range of absolute maximum rating on the transient state, such as power-on, power-off and mode-switching. Otherwise, we will not be liable for any defect which may arise later in your equipment.
 - Even when the products are used within the guaranteed values, take into the consideration of incidence of break down and failure mode, possible to occur to semiconductor products. Measures on the systems such as redundant design, arresting the spread of fire or preventing glitch are recommended in order to prevent physical injury, fire, social damages, for example, by using the products.
- (6) Comply with the instructions for use in order to prevent breakdown and characteristics change due to external factors (ESD, EOS, thermal stress and mechanical stress) at the time of handling, mounting or at customer's process. When using products for which damp-proof packing is required, satisfy the conditions, such as shelf life and the elapsed time since first opening the packages.
- (7) This book may be not reprinted or reproduced whether wholly or partially, without the prior written permission of our company.