

October 3, 2000

TEL:805-498-2111 FAX:805-498-3804 WEB:http://www.semtech.com

DESCRIPTION

The SC1565 is a high performance positive voltage regulator designed for use in applications requiring very low dropout voltage at up to 1.5 Amps. Since it has superior dropout characteristics compared to regular LDOs, it can be used to supply 2.5V on motherboards or 2.8V on peripheral cards from the 3.3V supply thus allowing the elimination of costly heatsinks. Additionally, the 5-lead TO-220 and SO-8 versions have an enable pin to further reduce power dissipation while shut down. The SC1565 provides excellent regulation over variations in line, load and temperature.

The SC1565 is available in the popular SO-8 surface mount package with two internally preset output voltage options, which are also adjustable using external resistors. Also available are 5-lead and 3-lead TO-220 2.5V options (fixed output only for the 3-lead option) and fixed output SOT-223 options.

FEATURES

- 350mV dropout @ 1.5A
- Adjustable output from 1.2V to 4.8V⁽¹⁾
- 2.5V and 1.8V options (adjustable externally using resistors)⁽¹⁾
- Over current and over temperature protection
- Enable pin⁽¹⁾
- 10µA quiescent current in shutdown⁽¹⁾
- Low reverse leakage (output to input)
- Surface mount and through-hole packages
- Full industrial temperature range

Note:

(1) SO-8 and TO-220-5L packages only.

APPLICATIONS

- Battery powered systems
- Motherboards
- Peripheral cards
- PCMCIA cards

ORDERING INFORMATION

DEVICE ⁽¹⁾	PACKAGE
SC1565IS-X.X.TR ⁽²⁾	SO-8
SC1565IST-X.X.TR ⁽²⁾	SOT-223
SC1565IT-X.X ⁽³⁾	TO-220-3
SC1565I5T-X.X ⁽³⁾	TO-220-5

Notes:

(1) Where -X.X denotes voltage options. Available voltages are: 2.5V and 1.8V. Output voltage can be adjusted (except SOT-223 and TO-220-3) using external resistors, see Pin Description.

(2) Only available in tape and reel packaging. A reel contains 2500 devices.

(3) Only available in tube packaging (no suffix required).

TYPICAL APPLICATIONS

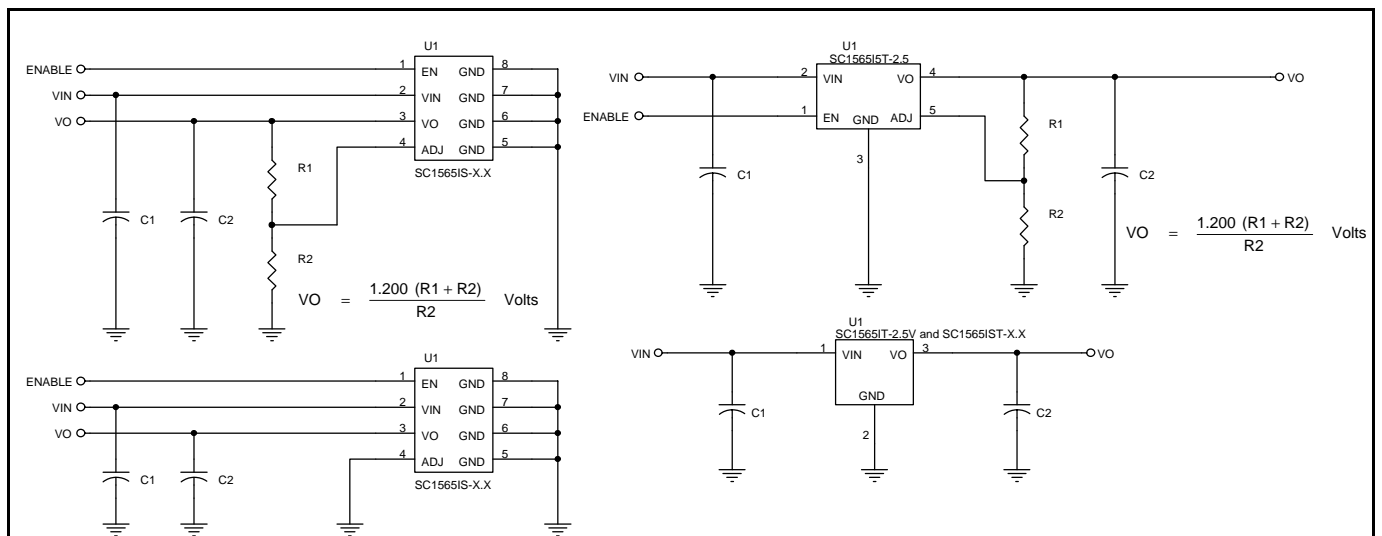

Notes:

(1) Maximum VO setpoint for 1.8V parts = 5.4V.

(2) This device is designed to operate with ceramic input and output capacitors.

October 3, 2000

ABSOLUTE MAXIMUM RATINGS

Parameter	Symbol	Max	Units
Input Voltage	V_{IN}	5.5	V
Power Dissipation	P_D	Internally Limited	W
Thermal Resistance Junction to Ambient SO-8 ⁽¹⁾ SOT-223 TO-220-X	θ_{JA}	65 63 50	°C/W
Thermal Resistance Junction to Case SO-8 SOT-223 TO-220-X	θ_{JC}	39 27 3	°C/W
Operating Ambient Temperature Range	T_A	-40 to 85	°C
Operating Junction Temperature Range	T_J	-40 to 150	°C
Storage Temperature Range	T_{STG}	-65 to 150	°C
Lead Temperature (Soldering) 10 Sec.	T_{LEAD}	300	°C
ESD Rating (Human body model)	ESD	4	kV

Note:

(1) 1 square inch of FR-4, double sided, 1 oz. minimum copper weight.

ELECTRICAL CHARACTERISTICS

 Unless specified: $V_{EN} = V_{IN}$

 Adjustable Option ($V_{ADJ} > V_{TH(ADJ)}$): $V_{IN} = 2.2$ to 5.5V and $I_O = 10\mu A$ to 1.5A

 Fixed Options ($V_{ADJ} = GND$): $V_{IN} = (V_O + 0.7V)$ to 5.5V and $I_O = 0A$ to 1.5A

 Values in **bold** apply over the full operating temperature range.

Parameter	Symbol	Test Conditions	Min	Typ	Max	Units
VIN						
Supply Voltage Range	V_{IN}		2.2		5.5	V
Quiescent Current	I_Q	$V_{IN} = 3.3V$		0.75	1.75	mA
		$V_{IN} = 5.5V, V_{EN} = 0V$		10	35	μA
VO						
Output Voltage ⁽¹⁾ (Internal Fixed Voltage)	V_O	$V_{IN} = V_O + 0.7V, I_O = 10mA$	$0.99V_O$	V_O	$1.01V_O$	V
			$0.98V_O$	V_O	$1.02V_O$	
Line Regulation ⁽¹⁾	$REG_{(LINE)}$	$V_{IN} = (V_O + 0.25V)$ to 5.5V, $I_{OUT} = 10mA$		0.035	0.3	%
Load Regulation ⁽¹⁾	$REG_{(LOAD)}$	$V_{IN} = V_O + 0.7V$		0.2	0.4	%

October 3, 2000

ELECTRICAL CHARACTERISTICS

 Unless specified: $V_{EN} = V_{IN}$

 Adjustable Option ($V_{ADJ} > V_{TH(ADJ)}$): $V_{IN} = 2.2$ to $5.5V$ and $I_O = 10\mu A$ to $1.5A$

 Fixed Options ($V_{ADJ} = GND$): $V_{IN} = (V_O + 0.7V)$ to $5.5V$ and $I_O = 0A$ to $1.5A$

 Values in **bold** apply over the full operating temperature range.

Parameter	Symbol	Test Conditions	Min	Typ	Max	Units	
Dropout Voltage ⁽²⁾	V_D	$I_{LOAD} = 10mA$		2.5	10	mV	
					20		
			$I_{LOAD} = 500mA$		115	300	mV
						400	
			$I_{LOAD} = 1A$		225	400	mV
						500	
			$I_{LOAD} = 1.5A$		350	500	mV
						600	
Minimum Load Current ⁽³⁾	I_O	$V_{IN} = V_O + 0.7V$		1	10	μA	
Current Limit	I_{CL}		1.50	2.50	3.50	A	
ADJ							
Reference Voltage ⁽¹⁾	V_{REF}	$V_{IN} = 2.2V, V_{ADJ} = V_{OUT}, I_O = 10mA$	1.188	1.200	1.212	V	
			1.176		1.224		
Adjust Pin Current ⁽⁴⁾	I_{ADJ}	$V_{ADJ} = V_{REF}$		10	50	nA	
Adjust Pin Threshold ⁽⁵⁾	$V_{TH(ADJ)}$		0.10	0.20	0.40	V	
EN							
Enable Pin Current	I_{EN}	$V_{EN} = 0V, V_{IN} = 3.3V$		1.5	10	μA	
Enable Pin Threshold	V_{IH}	$V_{IN} = 3.3V$	1.8			V	
	V_{IL}	$V_{IN} = 3.3V$			0.4		
OVER TEMPERATURE PROTECTION							
High Trip level	T_{HI}			170		$^{\circ}C$	
Hysteresis	T_{HYST}			20		$^{\circ}C$	

NOTES:

(1) Low duty cycle pulse testing with Kelvin connections required.

(2) Defined as the input to output differential at which the output voltage drops to 1% below the value measured at a differential of 0.7V.

(3) Required to maintain regulation. Voltage set resistors R1 and R2 are usually utilized to meet this requirement. Adjustable versions only.

(4) Guaranteed by design.

 (5) When V_{ADJ} exceeds this threshold, the "Sense Select" switch disconnects the internal feedback chain from the error amplifier and connects V_{ADJ} instead.

October 3, 2000

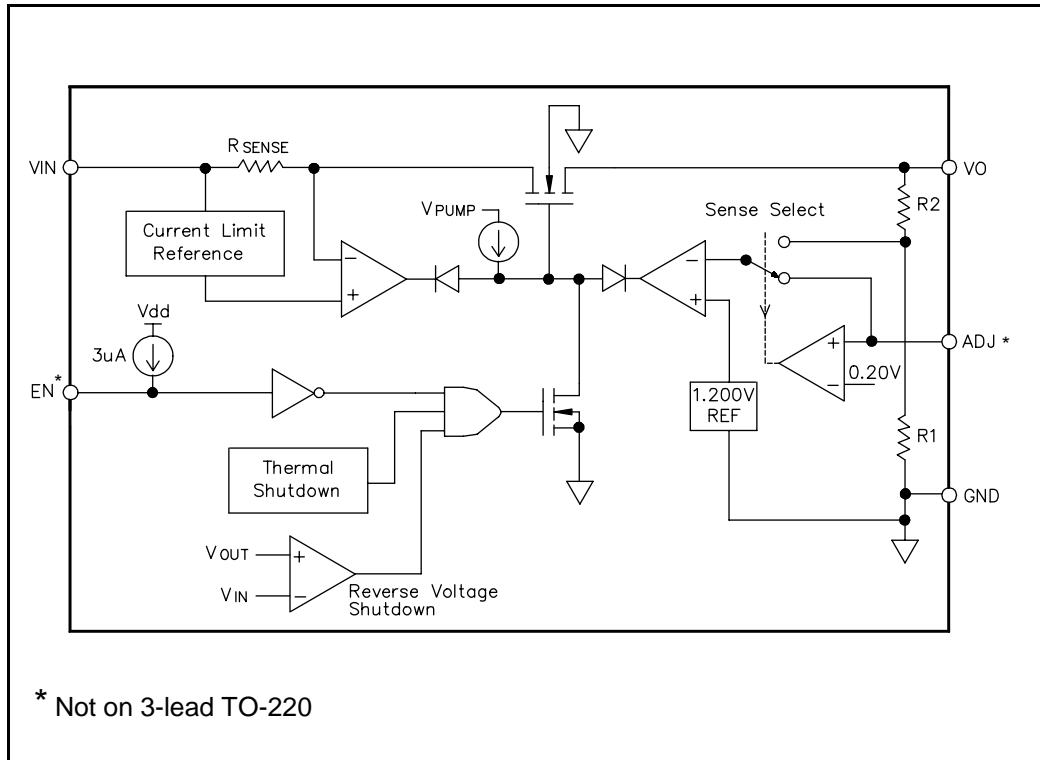
BLOCK DIAGRAM

PIN DESCRIPTIONS

Pin Name	Pin Function
ADJ	This pin, when grounded, sets the output voltage to that set by the internal feedback resistors. If external feedback resistors are used, the output voltage will be (See Application Circuit): $VO = \frac{1.200 (R1 + R2)}{R2} \text{ Volts}$
EN	Enable Input. Pulling this pin below 0.4V turns the regulator off, reducing the quiescent current to a fraction of its operating value. The device will be enabled if this pin is left open. Connect to VIN if not being used.
GND	Reference ground. Use all four pins on the SO-8 device for heatsinking. Use the tab on the TO-220 devices for heatsinking.
VIN	Input voltage. For regulation at full load, the input to this pin must be between (VO + 0.7V) and 5.5V. Minimum VIN = 2.2V.
VO	This pin is the power output of the device.

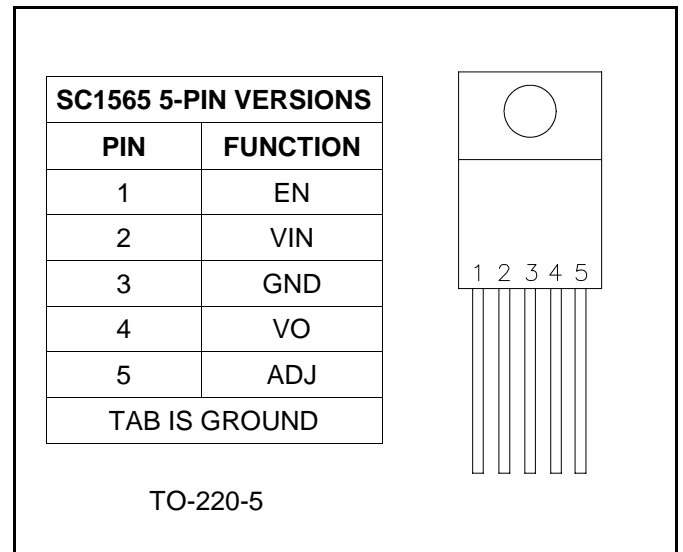
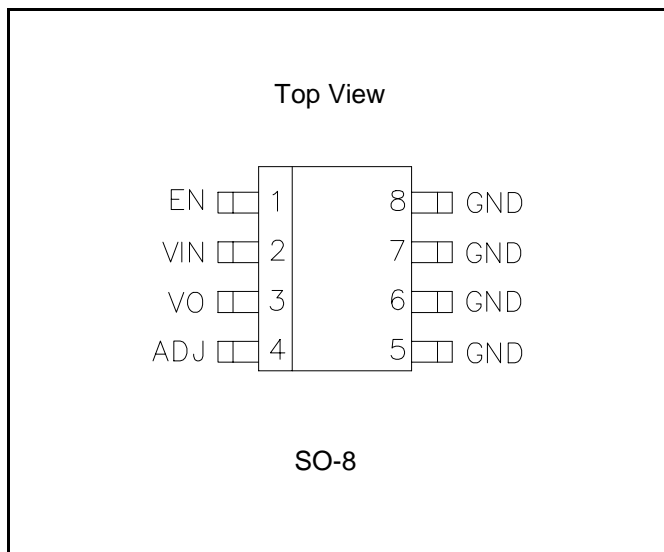
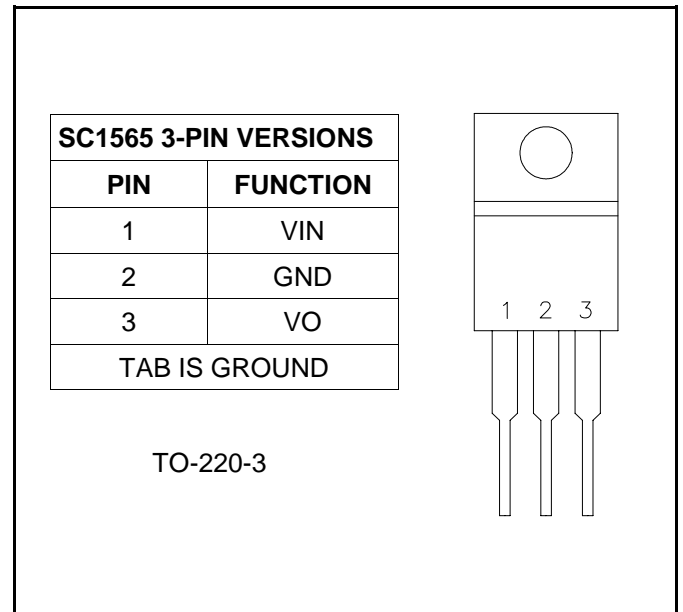
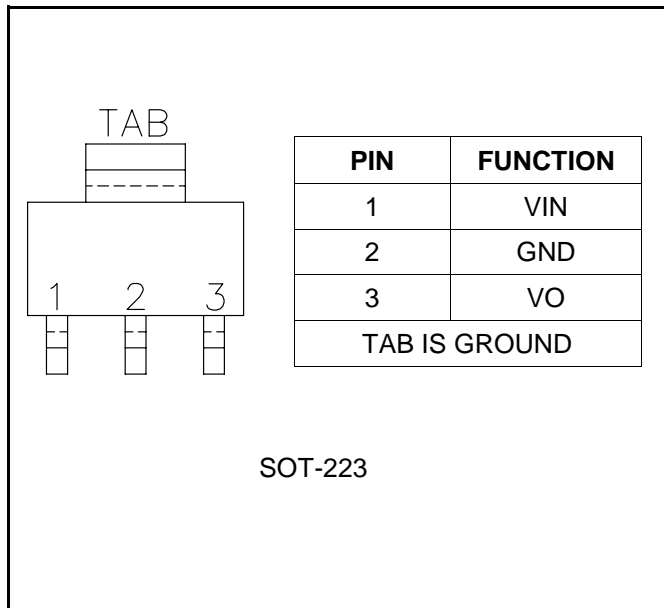
October 3, 2000

PIN CONFIGURATIONS

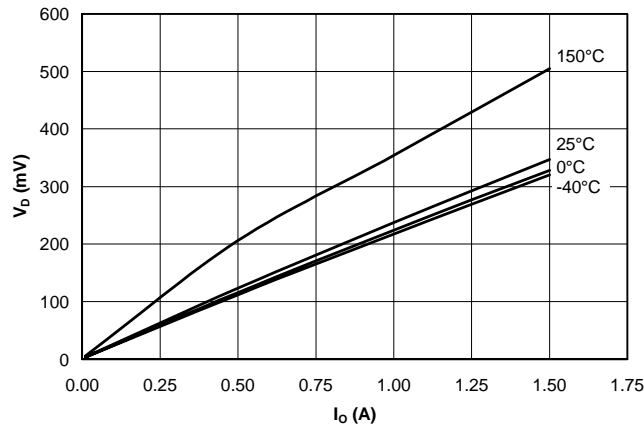
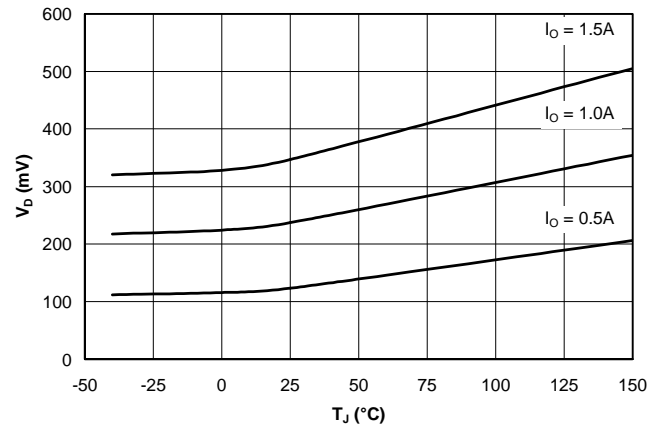
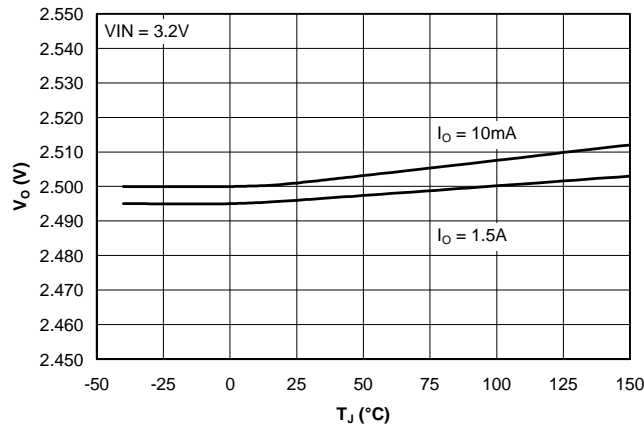
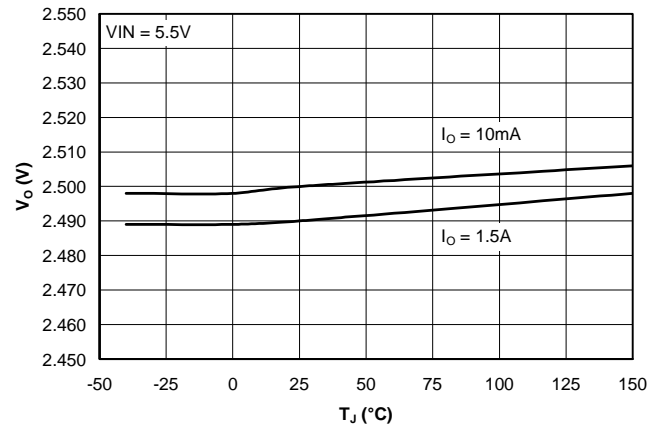
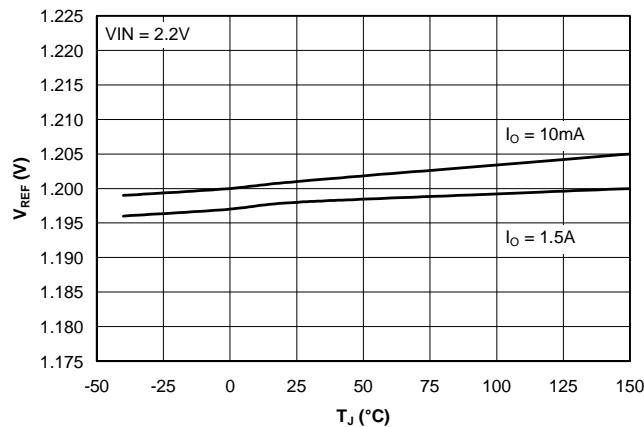
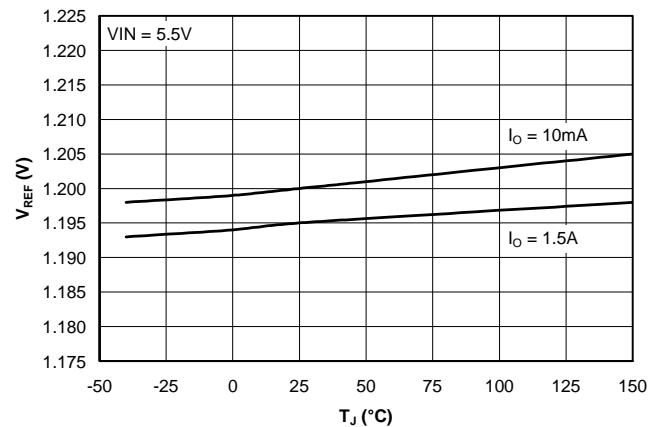
October 3, 2000

TYPICAL CHARACTERISTICS
**Dropout Voltage vs. Output Current
vs. Junction Temperature**

**Dropout Voltage vs. Junction
Temperature vs. Output Current**

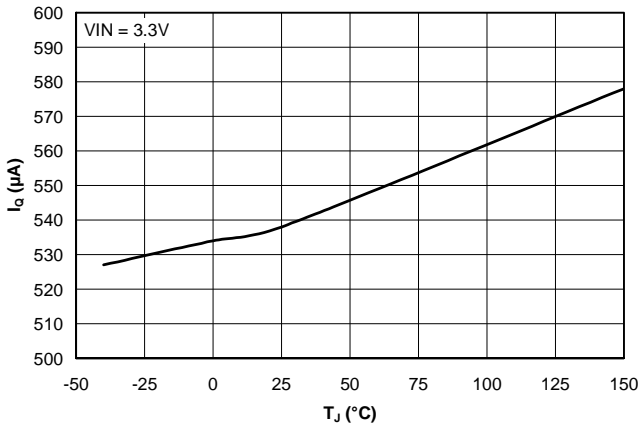
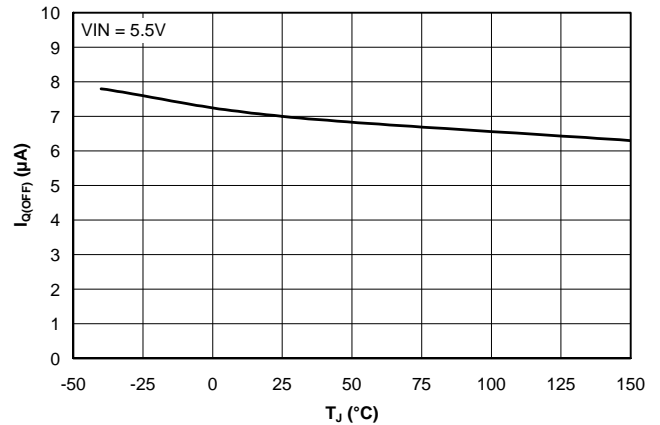
**Output Voltage (2.5V) vs. Junction
Temperature vs. Output Current**

**Output Voltage (2.5V) vs. Junction
Temperature vs. Output Current**

**Reference Voltage vs. Junction
Temperature vs. Output Current**

**Reference Voltage vs. Junction
Temperature vs. Output Current**

October 3, 2000

TYPICAL CHARACTERISTICS (Cont.)
**Quiescent Current vs.
Junction Temperature**

**Off-State Quiescent Current vs.
Junction Temperature**

APPLICATIONS INFORMATION
Introduction

The SC1565 is intended for applications such as graphics cards where high current capability and very low dropout voltage are required. It provides a very simple, low cost solution that uses very little pcb real estate. Additional features include an enable pin to allow for a very low power consumption standby mode, and a fully adjustable output.

Component Selection

Input capacitor - a 4.7µF ceramic capacitor is recommended. This allows for the device being some distance from any bulk capacitance on the rail. Additionally, input droop due to load transients is reduced, improving load transient response. Additional capacitance may be added if required by the application.

Output capacitor - a minimum bulk capacitance of 10µF, along with a 0.1µF ceramic decoupling capacitor is recommended. Increasing the bulk capacitance will improve the overall transient response. The use of multiple lower value ceramic capacitors in parallel to achieve the desired bulk capacitance will not cause stability issues. Although designed for use with ceramic output capacitors, the SC1565 is extremely tolerant of output capacitor ESR values and thus will also work comfortably with tantalum output capacitors.

External voltage selection resistors - the use of 1% resistors, and designing for a current flow $\geq 10\mu\text{A}$ is recommended to ensure a well regulated output (thus R2 $\leq 120\text{k}\Omega$).

Thermal Considerations

The power dissipation in the SC1565 is approximately equal to the product of the output current and the input to output voltage differential:

$$P_D \approx (V_{IN} - V_{OUT}) \cdot I_O$$

The absolute worst-case dissipation is given by:

$$P_{D(MAX)} = (V_{IN(MAX)} - V_{OUT(MIN)}) \cdot I_{O(MAX)} + V_{IN(MAX)} \cdot I_{Q(MAX)}$$

For a typical scenario, $V_{IN} = 3.3\text{V} \pm 5\%$, $V_{OUT} = 2.8\text{V}$ and $I_O = 1.5\text{A}$, therefore:

$$V_{IN(MAX)} = 3.465\text{V}, V_{OUT(MIN)} = 2.744\text{V} \text{ and } I_{Q(MAX)} = 1.75\text{mA},$$

$$\text{Thus } P_{D(MAX)} = 1.09\text{W}.$$

Using this figure, and assuming $T_{A(MAX)} = 70^\circ\text{C}$, we can calculate the maximum thermal impedance allowable to maintain $T_J \leq 150^\circ\text{C}$:

$$R_{TH(J-A)(MAX)} = \frac{(T_{J(MAX)} - T_{A(MAX)})}{P_{D(MAX)}} = \frac{(150 - 70)}{1.09} = 73.4^\circ\text{C} / \text{W}$$

This should be achievable for the SO-8 package using pcb copper area to aid in conducting the heat away, such as one square inch of copper connected to the ground pins of the device. The SOT-223 and TO-220 packages would not require heatsinking. Internal ground/power planes and air flow will also assist in removing heat. For higher ambient temperatures it may be necessary to use additional copper area.

October 3, 2000

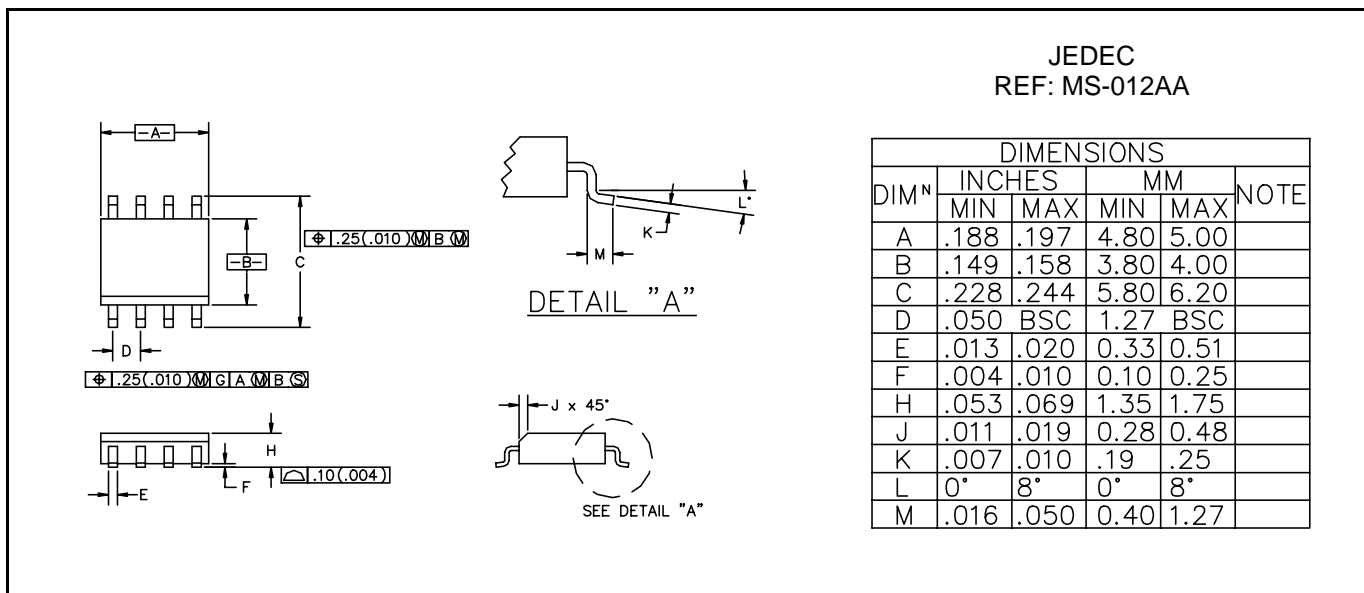
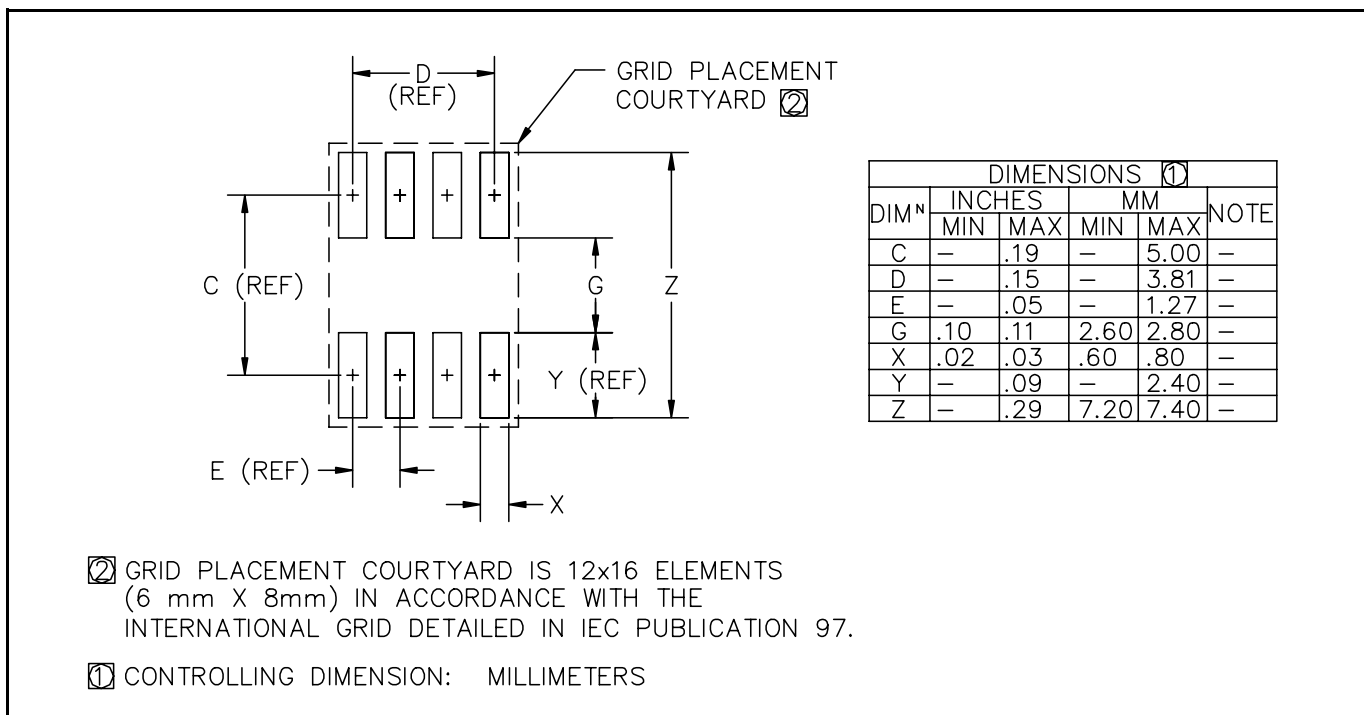
OUTLINE DRAWING - SO-8

LAND PATTERN - SO-8

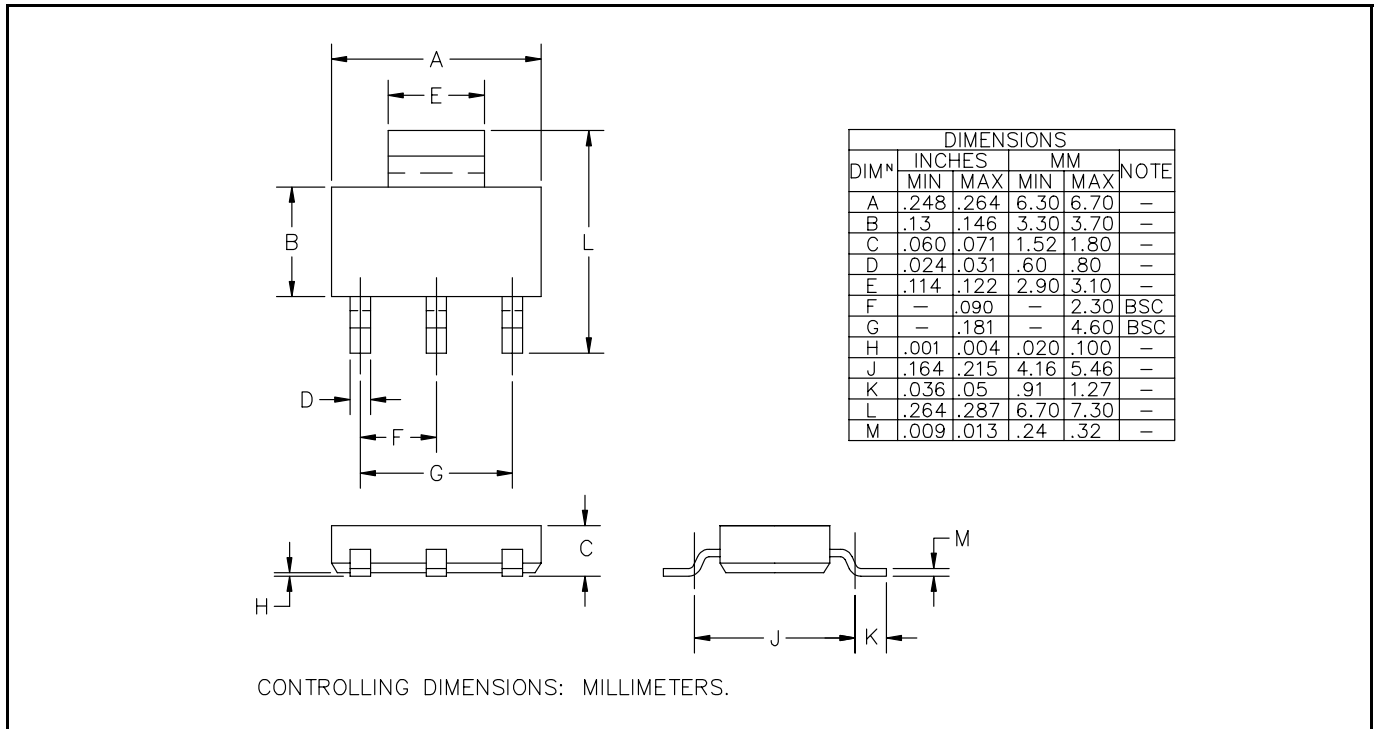
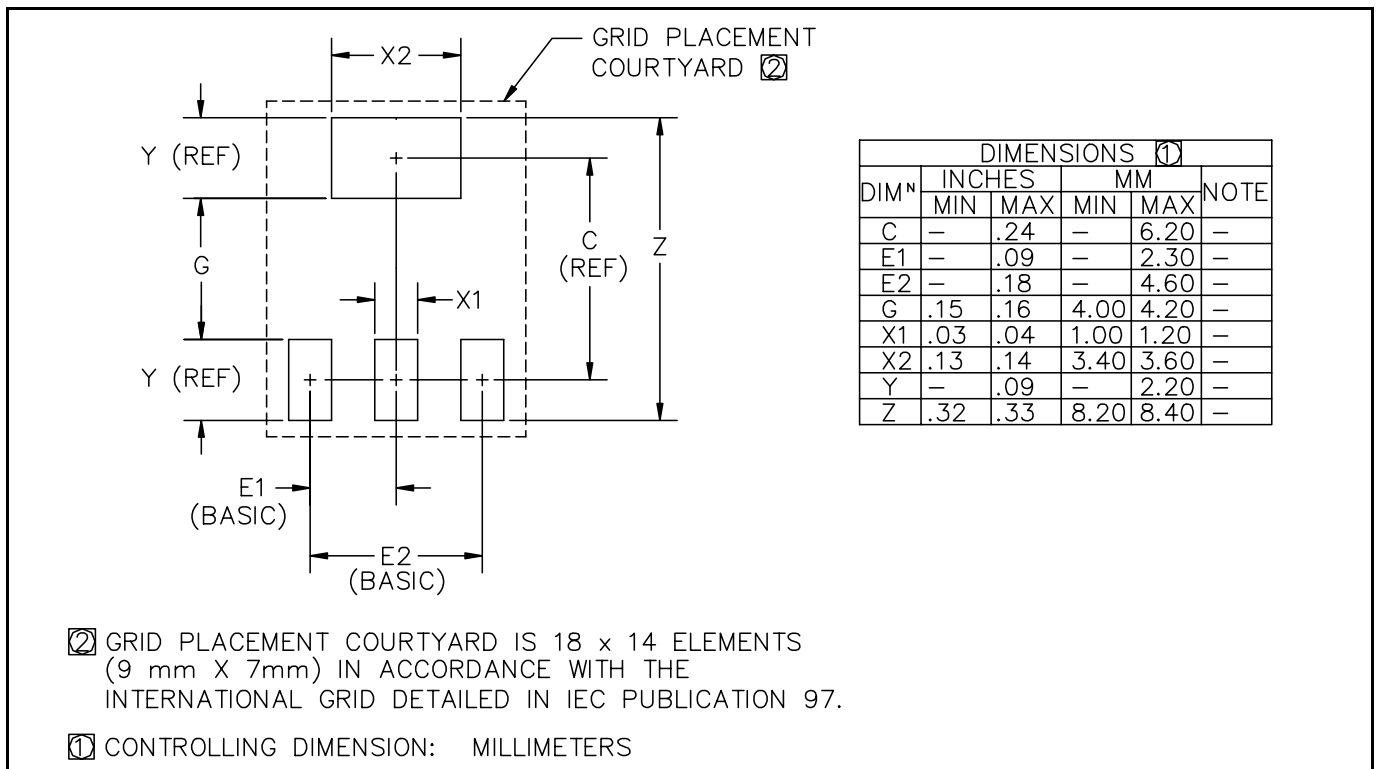
October 3, 2000

DEVICE OUTLINE SOT-223

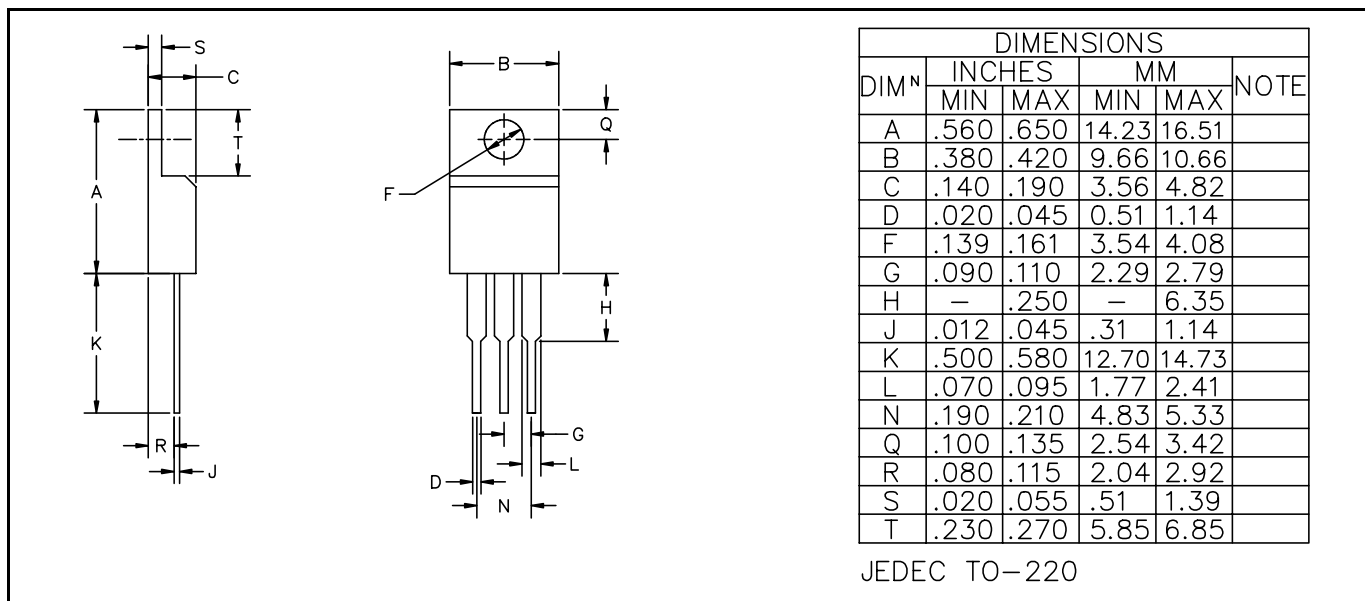
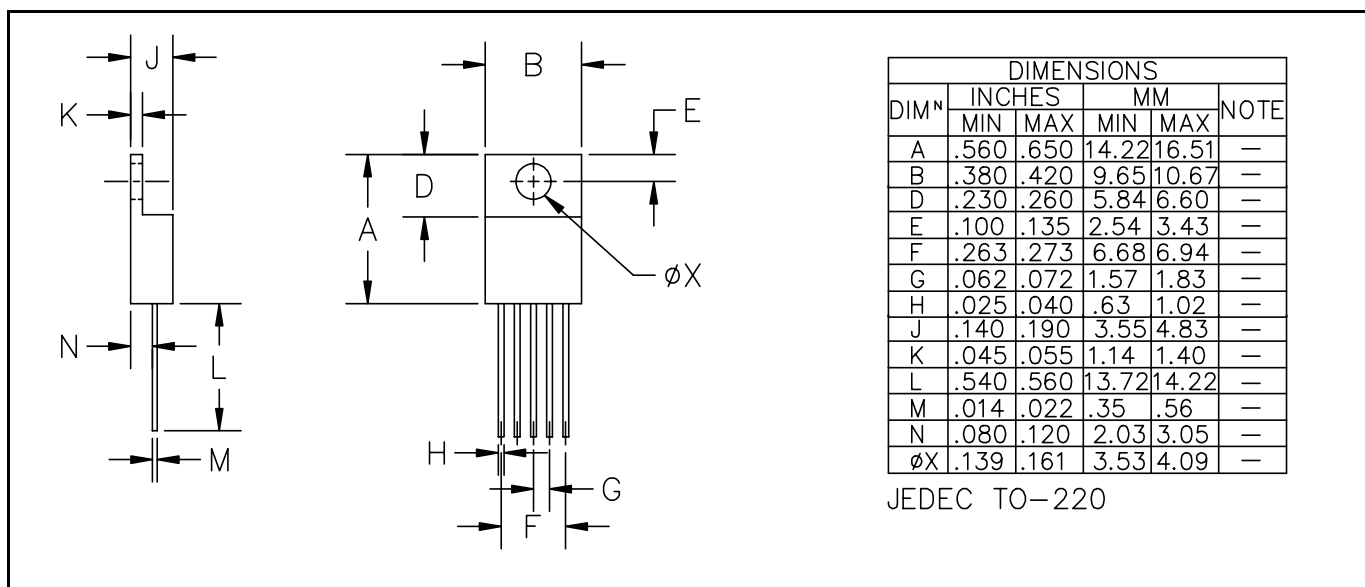
LAND PATTERN SOT-223

October 3, 2000

DEVICE OUTLINE - TO-220-3L

DEVICE OUTLINE - TO-220-5L

ECN00-1357