

**NPN EPITAXIAL SILICON POWER TRANSISTOR**

**CSC1507**

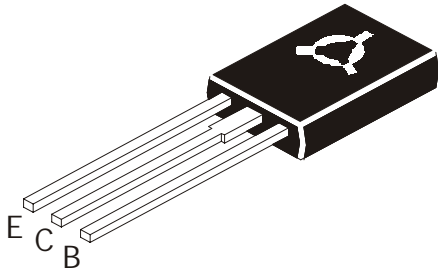

**TO126  
Plastic Package**

**Color TV Chroma Output**

**ABSOLUTE MAXIMUM RATINGS**

DESCRIPTION	SYMBOL	VALUE	UNIT
Collector -Base Voltage	$V_{CBO}$	300	V
Collector -Emitter Voltage	$V_{CEO}$	300	V
Emitter Base Voltage	$V_{EBO}$	7	V
Collector Current	$I_C$	200	mA
Collector Dissipation @ $T_c=25^\circ C$	$P_C$	10	W
Junction Temperature	$T_j$	150	$^\circ C$
Storage Temperature Range	$T_{stg}$	-55 to +150	$^\circ C$

**ELECTRICAL CHARACTERISTICS ( $T_a=25^\circ C$  unless specified otherwise)**

DESCRIPTION	SYMBOL	TEST CONDITION	MIN	TYP	MAX	UNIT
Collector Base Voltage	$V_{CBO}$	$I_C=100\mu A, I_E=0$	300	-	-	V
Collector Emitter Voltage	$V_{CEO}$	$I_C=10mA, I_B=0$	300	-	-	V
Emitter Base Voltage	$V_{EBO}$	$I_E=10\mu A, I_C=0$	7	-	-	V
Collector Cut off Current	$I_{CBO}$	$V_{CB}=200V, I_E=0$	-	-	100	$\mu A$
DC Current Gain	$h_{FE}$	$I_C=10mA, V_{CE}=10V$	40	-	240	
Collector Emitter Saturation Voltage	$V_{CE(Sat)}$	$I_C=50mA, I_B=5mA$	-	-	2.0	V
Current Gain - Bandwidth Product	$f_T$	$I_C=10mA, V_{CE}=30V$	40	-	-	MHz
Output Capacitance	$C_{ob}$	$V_{CB}=50V, I_E=0$ $f=1MHz$	-	4	-	pF

Classification	R	O	Y	G
$h_{FE}$	40 - 80	70 - 140	120 - 240	200 - 400

TO-126 (SOT-32) Plastic Package

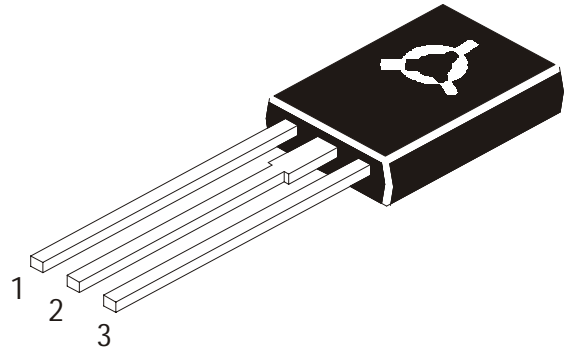
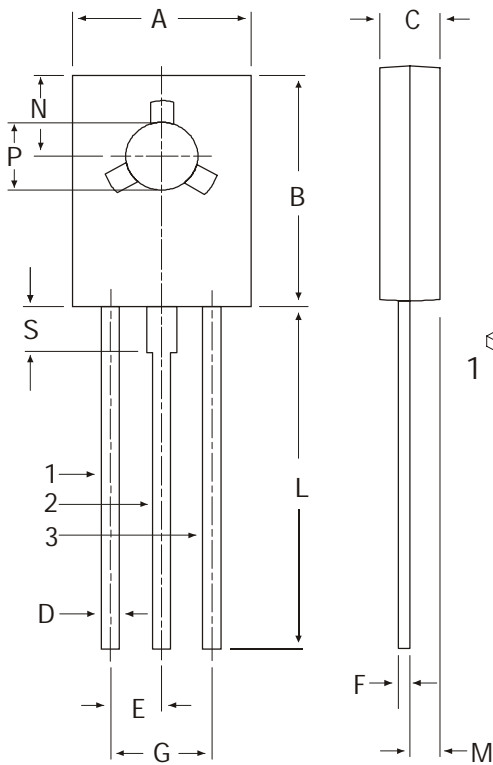

Pin Configuration

1. Emitter
2. Collector
3. Base

DIM	MIN	MAX
A	7.4	7.8
B	10.5	10.8
C	2.4	2.7
D	0.7	0.9
E	2.25 TYP.	
F	0.49	0.75
G	4.5 TYP.	
L	15.7 TYP.	
M	1.27 TYP.	
N	3.75 TYP.	
P	3.0	3.2
S	2.5 TYP.	

All dimensions in mm.

Packing Detail

PACKAGE	STANDARD PACK		INNER CARTON BOX		OUTER CARTON BOX		
	Details	Net Weight/Qty	Size	Qty	Size	Qty	Gr Wt
TO-126 Bulk	500 pcs/polybag	340 gm/500 pcs	3" x 7.5" x 7.5"	2K	17" x 15" x 13.5"	32K	31 kgs
TO-126 Tube	50 pcs/tube	73 gm/50 pcs	3" x 3.7" x 21.5"	1K	19" x 19" x 19"	10K	15 kgs

### Disclaimer

The product information and the selection guides facilitate selection of the CDIL's Discrete Semiconductor Device(s) best suited for application in your product(s) as per your requirement. It is recommended that you completely review our Data Sheet(s) so as to confirm that the Device(s) meet functionality parameters for your application. The information furnished in the Data Sheet and on the CDIL Web Site/CD are believed to be accurate and reliable. CDIL however, does not assume responsibility for inaccuracies or incomplete information. Furthermore, CDIL does not assume liability whatsoever, arising out of the application or use of any CDIL product; neither does it convey any license under its patent rights nor rights of others. These products are not designed for use in life saving/support appliances or systems. CDIL customers selling these products (either as individual Discrete Semiconductor Devices or incorporated in their end products), in any life saving/support appliances or systems or applications do so at their own risk and CDIL will not be responsible for any damages resulting from such sale(s).

CDIL strives for continuous improvement and reserves the right to change the specifications of its products without prior notice.



CDIL is a registered Trademark of

**Continental Device India Limited**

C-120 Naraina Industrial Area, New Delhi 110 028, India.

Telephone + 91-11-2579 6150, 5141 1112 Fax + 91-11-2579 5290, 5141 1119  
email@cdil.com www.cdilsemi.com