

To our customers,

---

## Old Company Name in Catalogs and Other Documents

---

On April 1<sup>st</sup>, 2010, NEC Electronics Corporation merged with Renesas Technology Corporation, and Renesas Electronics Corporation took over all the business of both companies. Therefore, although the old company name remains in this document, it is a valid Renesas Electronics document. We appreciate your understanding.

Renesas Electronics website: <http://www.renesas.com>

April 1<sup>st</sup>, 2010  
Renesas Electronics Corporation

Issued by: Renesas Electronics Corporation (<http://www.renesas.com>)

Send any inquiries to <http://www.renesas.com/inquiry>.

## Notice

1. All information included in this document is current as of the date this document is issued. Such information, however, is subject to change without any prior notice. Before purchasing or using any Renesas Electronics products listed herein, please confirm the latest product information with a Renesas Electronics sales office. Also, please pay regular and careful attention to additional and different information to be disclosed by Renesas Electronics such as that disclosed through our website.
2. Renesas Electronics does not assume any liability for infringement of patents, copyrights, or other intellectual property rights of third parties by or arising from the use of Renesas Electronics products or technical information described in this document. No license, express, implied or otherwise, is granted hereby under any patents, copyrights or other intellectual property rights of Renesas Electronics or others.
3. You should not alter, modify, copy, or otherwise misappropriate any Renesas Electronics product, whether in whole or in part.
4. Descriptions of circuits, software and other related information in this document are provided only to illustrate the operation of semiconductor products and application examples. You are fully responsible for the incorporation of these circuits, software, and information in the design of your equipment. Renesas Electronics assumes no responsibility for any losses incurred by you or third parties arising from the use of these circuits, software, or information.
5. When exporting the products or technology described in this document, you should comply with the applicable export control laws and regulations and follow the procedures required by such laws and regulations. You should not use Renesas Electronics products or the technology described in this document for any purpose relating to military applications or use by the military, including but not limited to the development of weapons of mass destruction. Renesas Electronics products and technology may not be used for or incorporated into any products or systems whose manufacture, use, or sale is prohibited under any applicable domestic or foreign laws or regulations.
6. Renesas Electronics has used reasonable care in preparing the information included in this document, but Renesas Electronics does not warrant that such information is error free. Renesas Electronics assumes no liability whatsoever for any damages incurred by you resulting from errors in or omissions from the information included herein.
7. Renesas Electronics products are classified according to the following three quality grades: “Standard”, “High Quality”, and “Specific”. The recommended applications for each Renesas Electronics product depends on the product’s quality grade, as indicated below. You must check the quality grade of each Renesas Electronics product before using it in a particular application. You may not use any Renesas Electronics product for any application categorized as “Specific” without the prior written consent of Renesas Electronics. Further, you may not use any Renesas Electronics product for any application for which it is not intended without the prior written consent of Renesas Electronics. Renesas Electronics shall not be in any way liable for any damages or losses incurred by you or third parties arising from the use of any Renesas Electronics product for an application categorized as “Specific” or for which the product is not intended where you have failed to obtain the prior written consent of Renesas Electronics. The quality grade of each Renesas Electronics product is “Standard” unless otherwise expressly specified in a Renesas Electronics data sheets or data books, etc.
  - “Standard”: Computers; office equipment; communications equipment; test and measurement equipment; audio and visual equipment; home electronic appliances; machine tools; personal electronic equipment; and industrial robots.
  - “High Quality”: Transportation equipment (automobiles, trains, ships, etc.); traffic control systems; anti-disaster systems; anti-crime systems; safety equipment; and medical equipment not specifically designed for life support.
  - “Specific”: Aircraft; aerospace equipment; submersible repeaters; nuclear reactor control systems; medical equipment or systems for life support (e.g. artificial life support devices or systems), surgical implantations, or healthcare intervention (e.g. excision, etc.), and any other applications or purposes that pose a direct threat to human life.
8. You should use the Renesas Electronics products described in this document within the range specified by Renesas Electronics, especially with respect to the maximum rating, operating supply voltage range, movement power voltage range, heat radiation characteristics, installation and other product characteristics. Renesas Electronics shall have no liability for malfunctions or damages arising out of the use of Renesas Electronics products beyond such specified ranges.
9. Although Renesas Electronics endeavors to improve the quality and reliability of its products, semiconductor products have specific characteristics such as the occurrence of failure at a certain rate and malfunctions under certain use conditions. Further, Renesas Electronics products are not subject to radiation resistance design. Please be sure to implement safety measures to guard them against the possibility of physical injury, and injury or damage caused by fire in the event of the failure of a Renesas Electronics product, such as safety design for hardware and software including but not limited to redundancy, fire control and malfunction prevention, appropriate treatment for aging degradation or any other appropriate measures. Because the evaluation of microcomputer software alone is very difficult, please evaluate the safety of the final products or system manufactured by you.
10. Please contact a Renesas Electronics sales office for details as to environmental matters such as the environmental compatibility of each Renesas Electronics product. Please use Renesas Electronics products in compliance with all applicable laws and regulations that regulate the inclusion or use of controlled substances, including without limitation, the EU RoHS Directive. Renesas Electronics assumes no liability for damages or losses occurring as a result of your noncompliance with applicable laws and regulations.
11. This document may not be reproduced or duplicated, in any form, in whole or in part, without prior written consent of Renesas Electronics.
12. Please contact a Renesas Electronics sales office if you have any questions regarding the information contained in this document or Renesas Electronics products, or if you have any other inquiries.

(Note 1) “Renesas Electronics” as used in this document means Renesas Electronics Corporation and also includes its majority-owned subsidiaries.

(Note 2) “Renesas Electronics product(s)” means any product developed or manufactured by or for Renesas Electronics.

## MONOLITHIC DUAL H BRIDGE DRIVER CIRCUIT

### DESCRIPTION

The  $\mu$ PD16803 is a monolithic dual H bridge driver circuit which uses N-channel power MOS FETs in its driver stage. By employing the power MOS FETs for the output stage, this driver circuit has a substantially improved saturation voltage and power consumption as compared with conventional driver circuits that use bipolar transistors.

In addition, the drive current can be adjusted by an external resistor in a power-saving mode.

The  $\mu$ PD16803 is therefore ideal as the driver circuit of the 2-phase excitation, bipolar-driven stepping motor for the head actuator of an FDD.

### FEATURES

- Low ON resistance (sum of ON resistors of top and bottom transistors)
  - $R_{ON1} = 1.5 \Omega$  TYP. ( $V_M = 5.0$  V)
  - $R_{ON2} = 2.0 \Omega$  TYP. ( $V_M = 12.0$  V)
- Low current consumption:  $I_{DD} = 0.4$  mA TYP.
- Stop mode function that turns OFF all output transistors
- Compact surface mount package: 20-pin plastic SOP (300 mil)

### PIN CONFIGURATION (Top View)

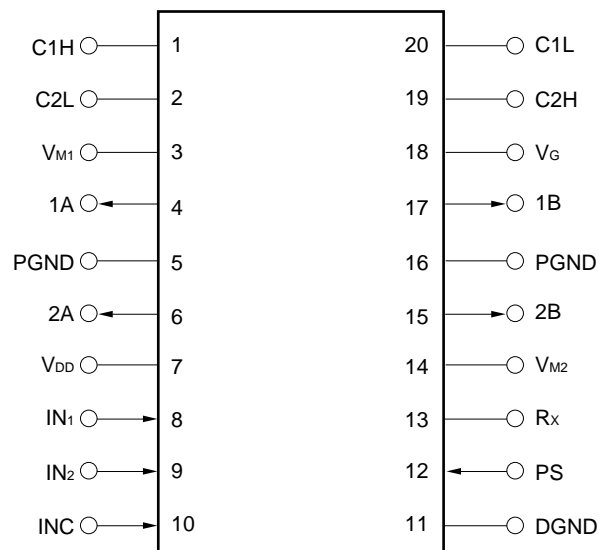

**ORDERING INFORMATION**

Part Number	Package
μPD16803GS	20-pin plastic SOP (300 mil)

**BLOCK DIAGRAM**

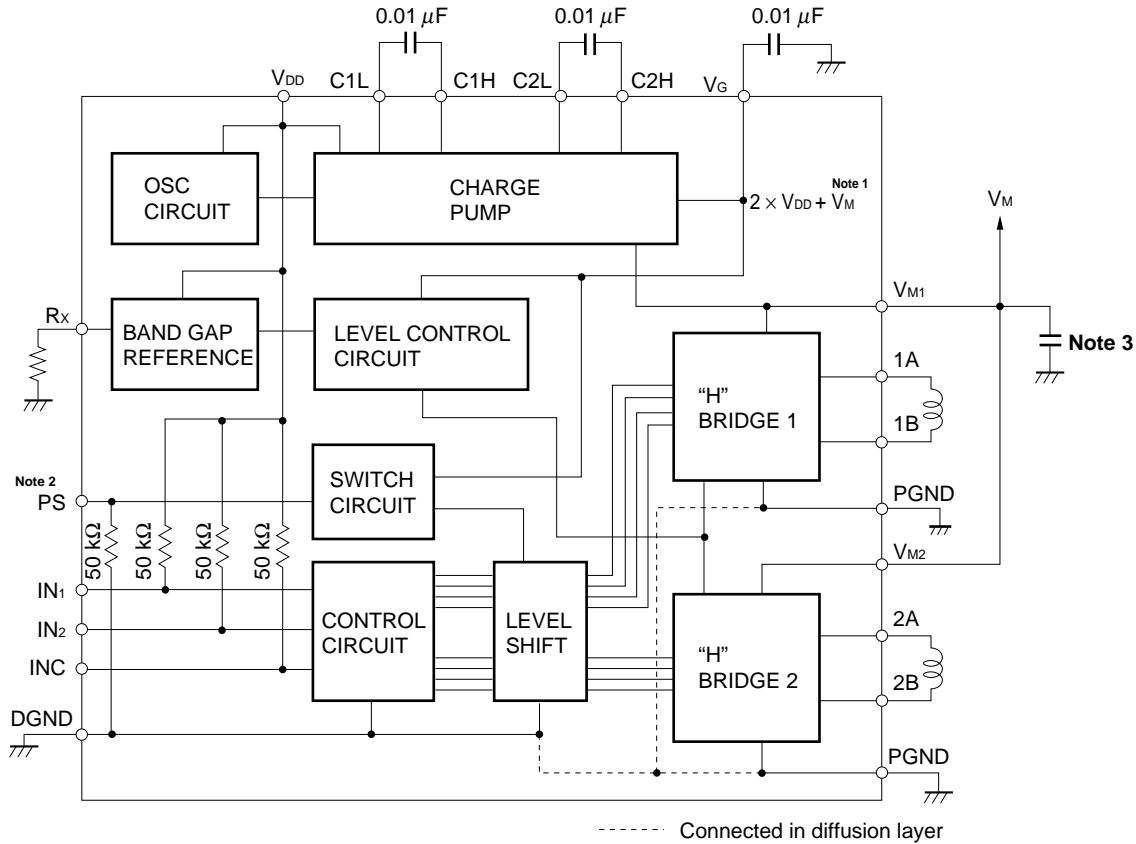

**Notes 1.**  $3 \times V_{DD}$  where  $V_M \leq V_{DD}$

2. The power-saving mode is set when the PS pin goes high. In this mode, the voltage of the charge pump circuit is lowered and the ON resistance of the H bridge driver transistor increases, limiting the current. In the power-saving mode, the motor cannot turn.
3. It is recommended to connect an external capacitor of  $0.22 \mu F$  or more between  $V_M$  and GND to stabilize the operation.

FUNCTION TABLE

Excitation Direction	INC	IN <sub>1</sub>	IN <sub>2</sub>	H <sub>1</sub>	H <sub>2</sub>
<1>	H	H	H	F	F
<2>	H	L	H	R	F
<3>	H	L	L	R	R
<4>	H	H	L	F	R
-	L	×	×	Stop	

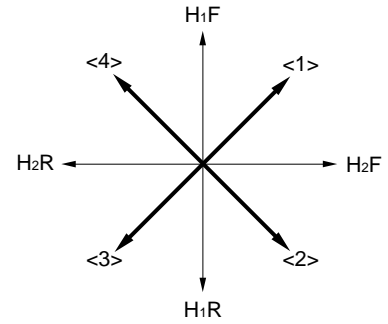

F: Forward  
R: Reverse

For the excitation waveform timing chart, refer to **APPLICATION EXAMPLE**.

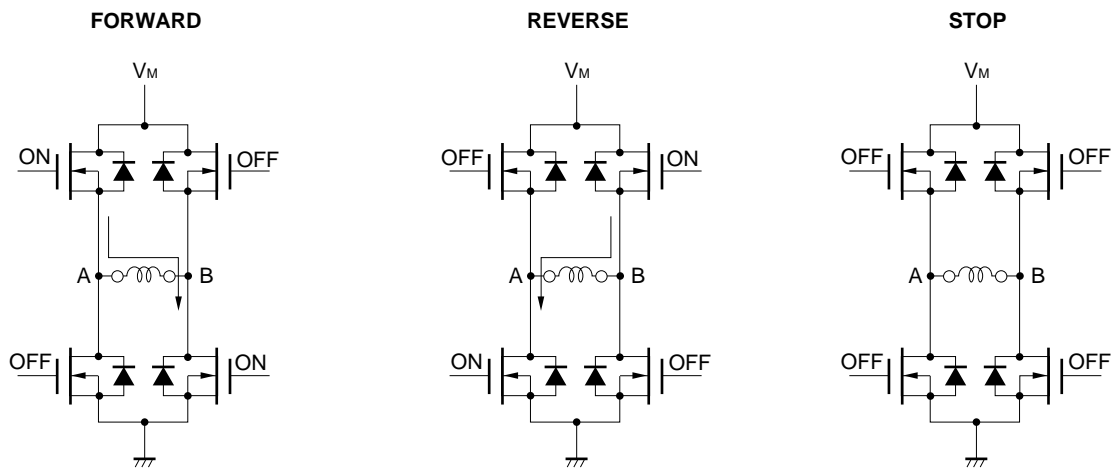

**ABSOLUTE MAXIMUM RATINGS (T<sub>A</sub> = 25 °C)**

Parameter	Symbol	Rating	Unit
Supply voltage (motor block)	V <sub>M</sub>	-0.5 to +15	V
Supply voltage (control block)	V <sub>DD</sub>	-0.5 to +7	V
Power consumption	P <sub>d1</sub>	1.0 <sup>Note 1</sup>	W
	P <sub>d2</sub>	1.25 <sup>Note 2</sup>	
Instantaneous H bridge driver current	I <sub>b</sub> (pulse)	±1.0 <sup>Note 2, 3</sup>	A
Input voltage	V <sub>IN</sub>	-0.5 to V <sub>DD</sub> + 0.5	V
Operating temperature range	T <sub>A</sub>	0 to 60	°C
Operation junction temperature	T <sub>JMAX.</sub>	150	°C
Storage temperature range	T <sub>stg</sub>	-55 to +125	°C

**Notes 1.** IC only

**2.** When mounted on a printed circuit board (100 × 100 × 1 mm, glass epoxy)

**3.** t ≤ 5 ms, Duty ≤ 40 %

**P<sub>d</sub> – T<sub>A</sub> Characteristics**

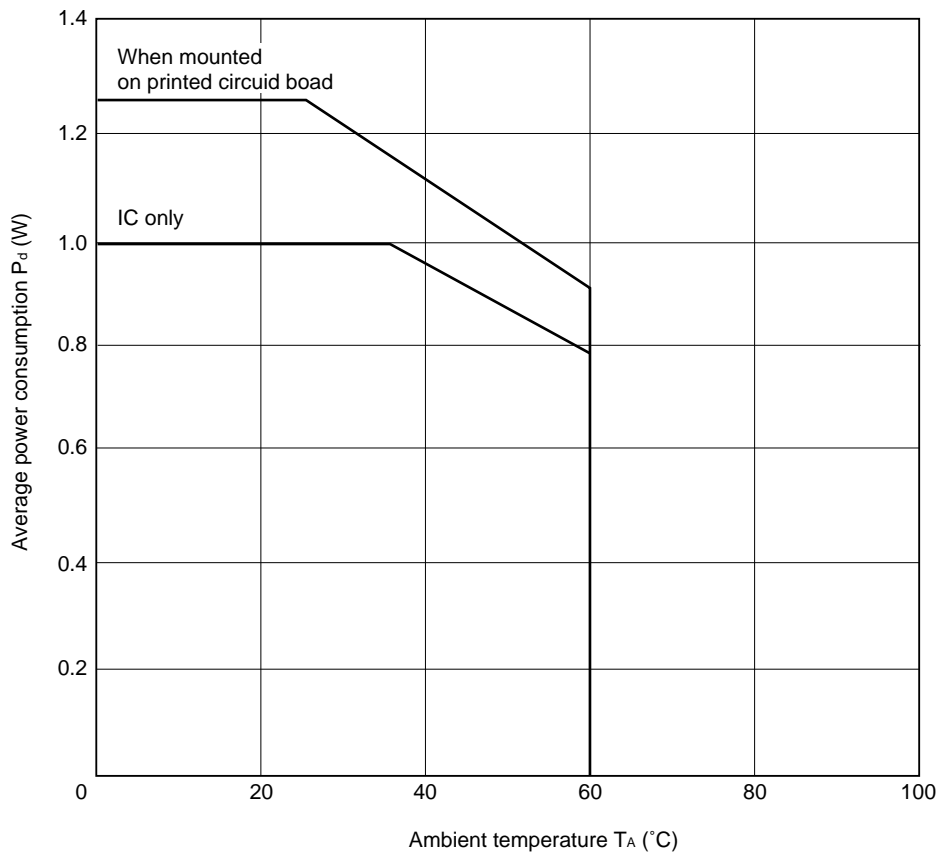

**RECOMMENDED OPERATING CONDITIONS**

Parameter	Symbol	MIN.	TYP.	MAX.	Unit
Supply voltage (motor block)	V <sub>M</sub>	4.0	5.0	13.2	V
Supply voltage (control block)	V <sub>DD</sub>	4.0	5.0	6.0	V
R <sub>x</sub> pin connection resistance	R <sub>x</sub>	2			kΩ
H bridge driver current <sup>Note</sup>	I <sub>DR</sub>			±380	mA
Charge pump capacitance	C <sub>1</sub> to C <sub>3</sub>	5		20	nF
Operating temperature	T <sub>A</sub>	0		60	°C

**Note** When mounted on a printed circuit board (100 × 100 × 1 mm, glass epoxy)

**ELECTRICAL SPECIFICATIONS (Within recommended operating conditions unless otherwise specified)**

Parameter	Symbol	Conditions	MIN.	TYP.	MAX.	Unit
OFF V <sub>M</sub> pin current	I <sub>M</sub>	INC pin low <sup>Note 1</sup> V <sub>M</sub> = 6.0 V V <sub>DD</sub> = 6.0 V			1.0	μA
		V <sub>M</sub> = 13.2 V V <sub>DD</sub> = 6.0 V			1.0	mA
V <sub>DD</sub> pin current	I <sub>DD</sub>	<b>Note 2</b>		0.4	1.0	mA
IN <sub>1</sub> , IN <sub>2</sub> , INC pin high-level input current	I <sub>IH1</sub>	T <sub>A</sub> = 25 °C, V <sub>IN</sub> = V <sub>DD</sub>			1.0	μA
		0 ≤ T <sub>A</sub> ≤ 60 °C, V <sub>IN</sub> = V <sub>DD</sub>			2.0	
IN <sub>1</sub> , IN <sub>2</sub> , INC pin low-level input current	I <sub>IL1</sub>	T <sub>A</sub> = 25 °C, V <sub>IN</sub> = 0 V			-0.15	mA
		0 ≤ T <sub>A</sub> ≤ 60 °C, V <sub>IN</sub> = 0 V			-0.2	
PS pin high-level input current	I <sub>IH2</sub>	T <sub>A</sub> = 25 °C, V <sub>IN</sub> = V <sub>DD</sub>			0.15	mA
		0 ≤ T <sub>A</sub> ≤ 60 °C, V <sub>IN</sub> = V <sub>DD</sub>			0.2	
PS pin low-level input current	I <sub>IL2</sub>	T <sub>A</sub> = 25 °C, V <sub>IN</sub> = 0 V			-1.0	μA
		0 ≤ T <sub>A</sub> ≤ 60 °C, V <sub>IN</sub> = 0 V			-2.0	
IN <sub>1</sub> , IN <sub>2</sub> , INC pin input pull-up resistance	R <sub>INU</sub>	T <sub>A</sub> = 25 °C	35	50	65	kΩ
		0 ≤ T <sub>A</sub> ≤ 60 °C	25		75	
PS pin input pull-down resistance	R <sub>IND</sub>	T <sub>A</sub> = 25 °C	35	50	65	kΩ
		0 ≤ T <sub>A</sub> ≤ 60 °C	25		75	
Control pin high-level input voltage	V <sub>IH</sub>		3.0		V <sub>DD</sub> + 0.3	V
Control pin low-level input voltage	V <sub>IL</sub>		-0.3		0.8	V
H bridge circuit ON resistance <sup>Note 3</sup>	R <sub>ON1</sub>	V <sub>DD</sub> = 5 V, V <sub>M</sub> = 5 V		1.5	3.0	Ω
	R <sub>ON2</sub>	V <sub>DD</sub> = 5 V, V <sub>M</sub> = 12 V		2.0	4.0	
R <sub>ON</sub> relative accuracy	ΔR <sub>ON</sub>	Excitation direction <2>, <4> <sup>Note 4</sup>			±5	%
		Excitation direction <1>, <3>			±10	
V <sub>x</sub> voltage in power-saving mode <sup>Note 5</sup>	V <sub>x</sub>	V <sub>DD</sub> = V <sub>M</sub> = 5 V, R <sub>x</sub> = 50 kΩ		2.5		V
V <sub>x</sub> relative accuracy in power-saving mode	ΔV <sub>x</sub>	Excitation direction <2>, <4> <sup>Note 4</sup>			±5	%
		Excitation direction <1>, <3>			±5	
Charge pump circuit (V <sub>G</sub> ) turn ON time	T <sub>ONG</sub>	V <sub>DD</sub> = 5 V, V <sub>M</sub> = 5 V		0.3	2	ms
H bridge circuit turn ON time	T <sub>ONH</sub>	C <sub>1</sub> = C <sub>2</sub> = C <sub>3</sub> = 10 nF			5	μs
H bridge circuit turn OFF time	T <sub>OFFH</sub>	R <sub>M</sub> = 20 Ω			5	μs

**Notes 1.** When V<sub>DD</sub> < V<sub>M</sub>, a current (I<sub>M1</sub>) always flow from the V<sub>M1</sub> pin to the charge pump circuit because a gate voltage (2 × V<sub>DD</sub> + V<sub>M</sub>) is generated.

**2.** When IN<sub>1</sub> = IN<sub>2</sub> = INC = “H”, PS = “L”

**3.** Sum of ON resistances of top and bottom transistors

**4.** For the excitation direction, refer to **FUNCTION TABLE**.

**5.** V<sub>x</sub> is a voltage at point A (FORWARD) or B (REVERSE) of the H bridge in Function Table.

CHARACTERISTIC CURVES

RON vs. VDD (= VM) Characteristics

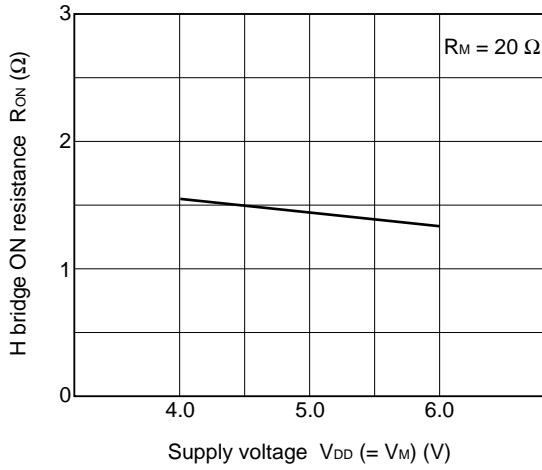

RON vs. VM Characteristics

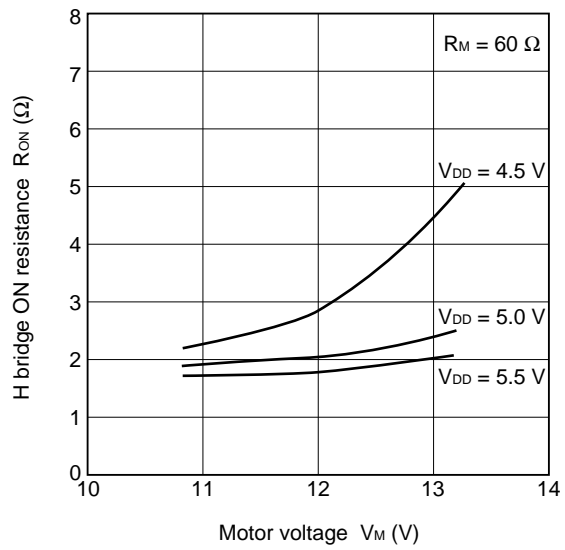

RON vs. Tj Characteristics

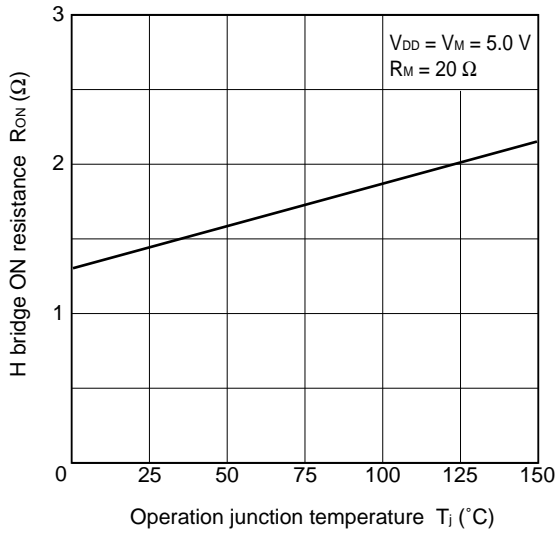

Vx vs. Rx Characteristics

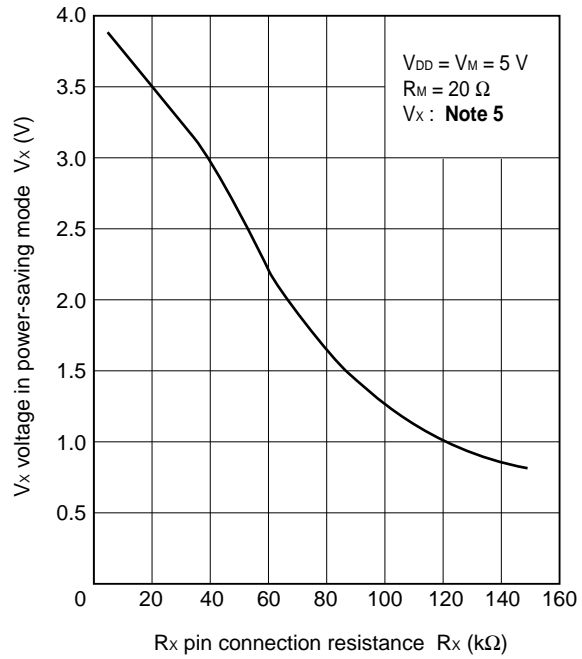

Vx vs. VDD (= VM) Characteristics

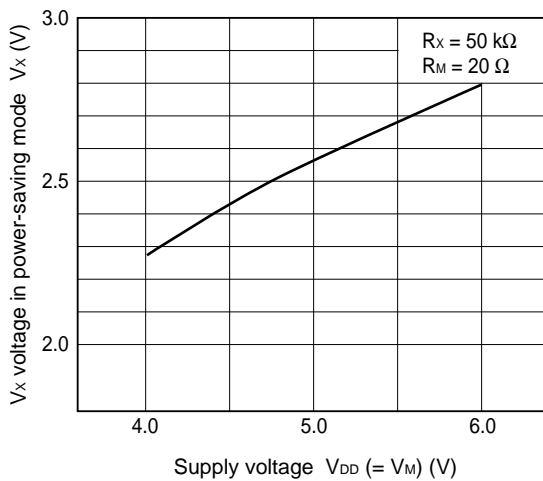



APPLICATION CIRCUIT EXAMPLE

1. Connection with 1-chip FDD LSI μPC2100AGF

μPC2100AGF Stepping Motor Excitation Timing Chart

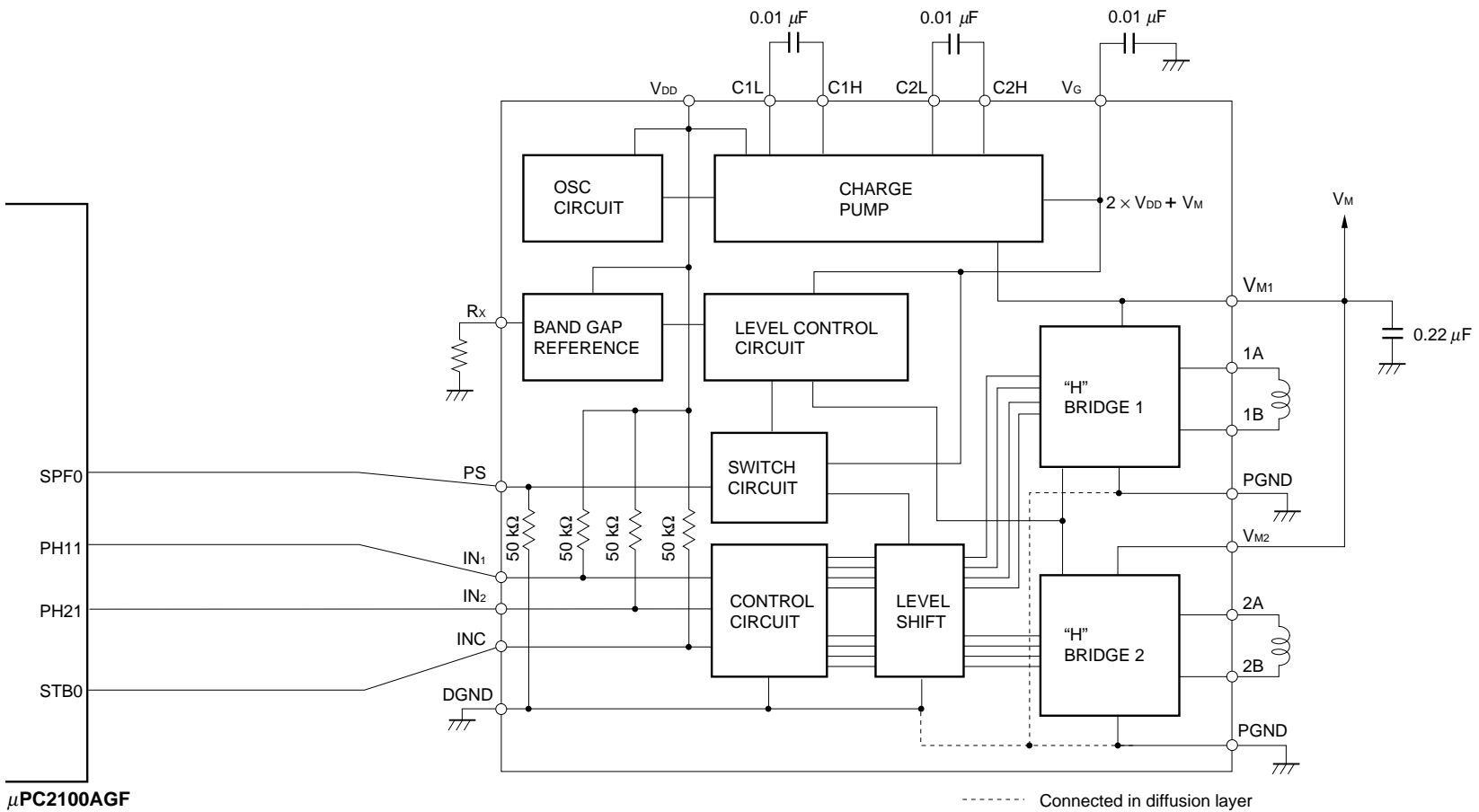
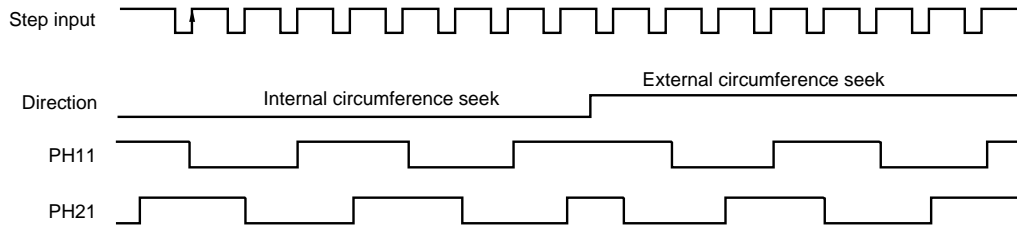

μPC2100AGF

2. Connection with 1-chip FDD LSI μPC2100AGF

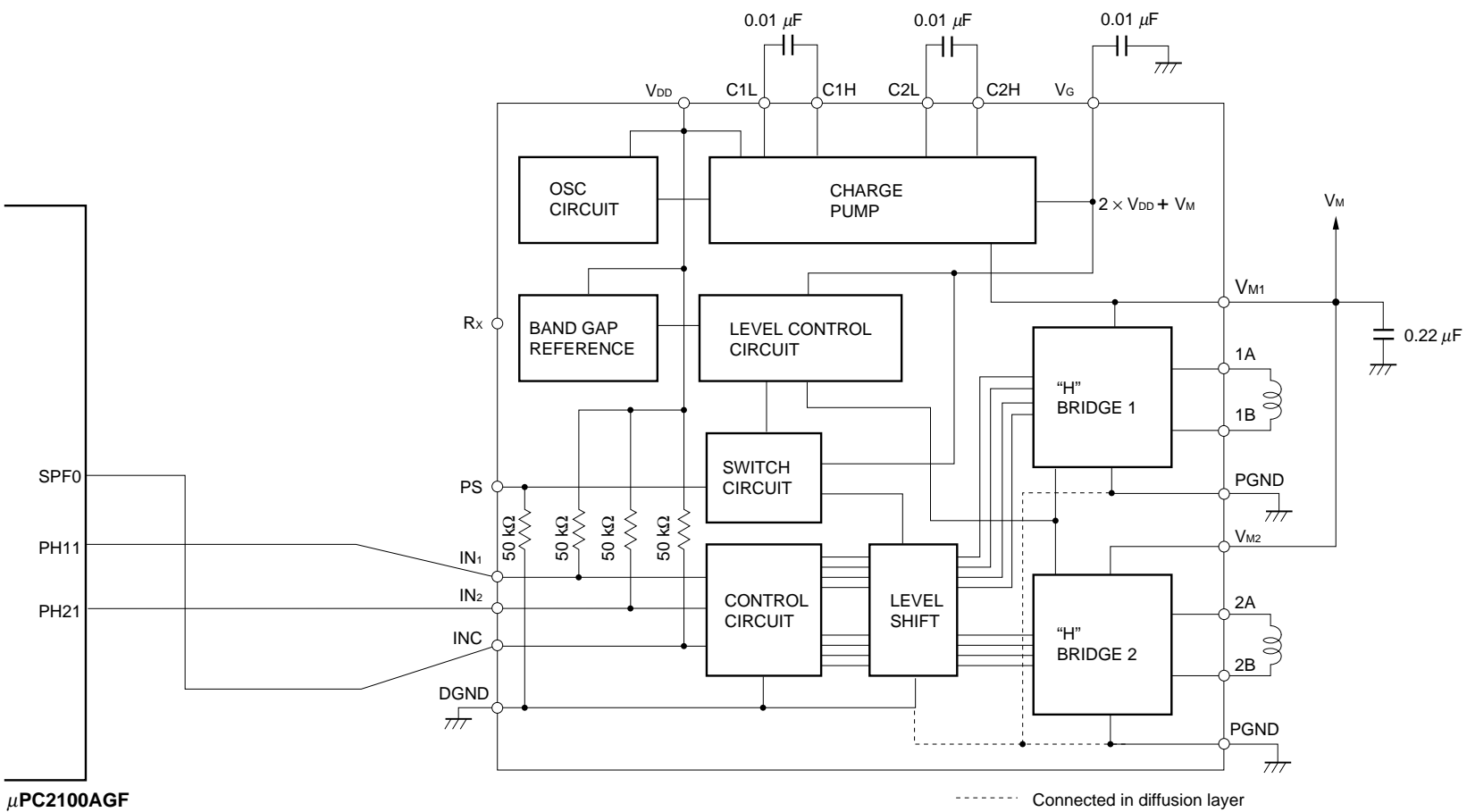

μPC2100AGF

The application circuits and their parameters are for reference only and are not intended for use in actual design-ins.

20 PIN PLASTIC SOP (300 mil)

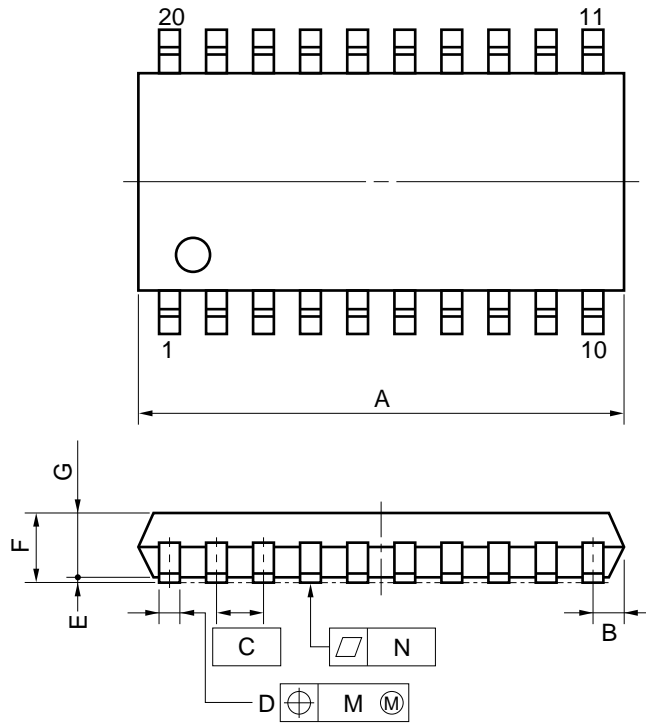

detail of lead end

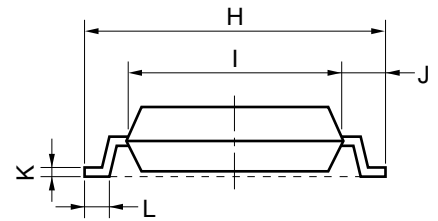
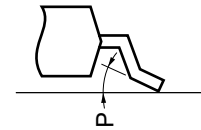

NOTE

Each lead centerline is located within 0.12 mm (0.005 inch) of its true position (T.P.) at maximum material condition.

ITEM	MILLIMETERS	INCHES
A	13.00 MAX.	0.512 MAX.
B	0.78 MAX.	0.031 MAX.
C	1.27 (T.P.)	0.050 (T.P.)
D	0.40 <sup>+0.10</sup> <sub>-0.05</sub>	0.016 <sup>+0.004</sup> <sub>-0.003</sub>
E	0.1±0.1	0.004±0.004
F	1.8 MAX.	0.071 MAX.
G	1.55	0.061
H	7.7±0.3	0.303±0.012
I	5.6	0.220
J	1.1	0.043
K	0.20 <sup>+0.10</sup> <sub>-0.05</sub>	0.008 <sup>+0.004</sup> <sub>-0.002</sub>
L	0.6±0.2	0.024 <sup>+0.008</sup> <sub>-0.009</sub>
M	0.12	0.005
N	0.10	0.004
P	3° <sup>+7°</sup> <sub>-3°</sub>	3° <sup>+7°</sup> <sub>-3°</sub>

P20GM-50-300B, C-4

## RECOMMENDED SOLDERING CONDITIONS

It is recommended to solder this product under the conditions described below.

For soldering methods and conditions other than those listed below, consult NEC.

### Surface mount type

For the details of the recommended soldering conditions of this type, refer to **Semiconductor Device Mounting Technology Manual (C10535E)**.

Soldering Method	Soldering Conditions	Symbol of Recommended Soldering
Infrared reflow	Peak package temperature: 230 °C, Time: 30 seconds MAX. (210 °C MIN.), Number of times: 1, Number of days: None <sup>Note</sup>	IR30-00
VPS	Peak package temperature: 215 °C, Time: 40 seconds MAX. (200 °C MIN.), Number of times: 1, Number of days: None <sup>Note</sup>	VP15-00
Wave soldering	Solder bath temperature: 260 °C MAX., Time: 10 seconds MAX., Number of times: 1, Number of days: None <sup>Note</sup>	WS60-00
Partial heating	Pin temperature: 300 °C MAX., Time: 10 seconds MAX., Number of days: None <sup>Note</sup>	—

**Note** The number of storage days at 25 °C, 65 % RH after the dry pack has been opened

**Caution** Do not use two or more soldering methods in combination (except partial heating).

[MEMO]

## [MEMO]

No part of this document may be copied or reproduced in any form or by any means without the prior written consent of NEC Corporation. NEC Corporation assumes no responsibility for any errors which may appear in this document.

NEC Corporation does not assume any liability for infringement of patents, copyrights or other intellectual property rights of third parties by or arising from use of a device described herein or any other liability arising from use of such device. No license, either express, implied or otherwise, is granted under any patents, copyrights or other intellectual property rights of NEC Corporation or others.

While NEC Corporation has been making continuous effort to enhance the reliability of its semiconductor devices, the possibility of defects cannot be eliminated entirely. To minimize risks of damage or injury to persons or property arising from a defect in an NEC semiconductor device, customers must incorporate sufficient safety measures in its design, such as redundancy, fire-containment, and anti-failure features.

NEC devices are classified into the following three quality grades:

"Standard", "Special", and "Specific". The Specific quality grade applies only to devices developed based on a customer designated "quality assurance program" for a specific application. The recommended applications of a device depend on its quality grade, as indicated below. Customers must check the quality grade of each device before using it in a particular application.

Standard: Computers, office equipment, communications equipment, test and measurement equipment, audio and visual equipment, home electronic appliances, machine tools, personal electronic equipment and industrial robots

Special: Transportation equipment (automobiles, trains, ships, etc.), traffic control systems, anti-disaster systems, anti-crime systems, safety equipment and medical equipment (not specifically designed for life support)

Specific: Aircrafts, aerospace equipment, submersible repeaters, nuclear reactor control systems, life support systems or medical equipment for life support, etc.

The quality grade of NEC devices is "Standard" unless otherwise specified in NEC's Data Sheets or Data Books. If customers intend to use NEC devices for applications other than those specified for Standard quality grade, they should contact an NEC sales representative in advance.

Anti-radioactive design is not implemented in this product.