

PREPARED BY: DATE: <i>H. Shoji Apr. 12, 2000</i>	<h1>SHARP</h1> <p>ELECTRONIC COMPONENTS GROUP SHARP CORPORATION</p> <h2>SPECIFICATION</h2>	SPEC. No. ED-00071
APPROVED BY: DATE: <i>K. Kusuda Apr 12, 2000</i>		ISSUE April 11, 2000
		PAGE 1 of 1
		REPRESENTATIVE DIVISION OPTO-ELECTRONIC DEVICES DIV.

DEVICE SPECIFICATION FOR
PHOTOCOUPLER

MODEL No. PC900V

(Business dealing name : PC900V0NSZX)

- These specification sheets include materials protected under copyright of Sharp Corporation ("Sharp"). Please do not reproduce or cause anyone to reproduce them without Sharp's consent.
- When using this product, please observe the absolute maximum ratings and the instructions for use outlined in these specification sheets, as well as the precautions mentioned below. Sharp assumes no responsibility for any damage resulting from use of the product which does not comply with the absolute maximum ratings and the instructions included in these specification sheets, and the precautions mentioned below.

(Precautions)

 - This product is designed for use in the following application areas ;

<ul style="list-style-type: none"> · OA equipment · Audio visual equipment · Home appliances · Telecommunication equipment (Terminal) · Measuring equipment · Tooling machines · Computers

If the use of the product in the above application areas is for equipment listed in paragraphs (2) or (3), please be sure to observe the precautions given in those respective paragraphs.
 - Appropriate measures, such as fail-safe design and redundant design considering the safety design of the overall system and equipment, should be taken to ensure reliability and safety when this product is used for equipment which demands high reliability and safety in function and precision, such as ;

<ul style="list-style-type: none"> · Transportation control and safety equipment (aircraft, train, automobile etc.) · Traffic signals · Gas leakage sensor breakers · Rescue and security equipment · Other safety equipment

 - Please do not use this product for equipment which require extremely high reliability and safety in function and precision, such as ;

<ul style="list-style-type: none"> · Space equipment · Telecommunication equipment (for trunk lines) · Nuclear power control equipment · Medical equipment
--
 - Please contact and consult with a Sharp sales representative if there are any questions regarding interpretation of the above three paragraphs.
- Please contact and consult with a Sharp sales representative for any questions about this product.

CUSTOMER'S APPROVAL

DATE _____

BY _____

DATE *Apr. 12, 2000*

PRESENTED *for*

BY *K. Hachimura*

K. Hachimura,
Department General Manager of
Engineering Dept.,II
Opto-Electronic Devices Div.
ELECOM Group
SHARP CORPORATION

Part No. ED-00071	April 11, 2000
MODEL NO. PC900VONSZX	PAGE 1/9

REFERENCE

1. Application

This specification applies to the outline and characteristics of photocoupler Model No. PC900V.

2. Outline

Refer to the attached sheet, page 3.

3. Ratings and characteristics

Refer to the attached sheet, page 3 to 5.

4. Reliability

Refer to the attached sheet, page 8.

5. Outgoing inspection

Refer to the attached sheet, page 9.

6. Supplement

6.1 Isolation voltage shall be measured in the following method.

- (1) Short among pins 1 to 3 on the primary side and among pins 4 to 6 on the secondary side.
- (2) The dielectric withstand tester with zero-cross circuit shall be used.
- (3) The wave form of applied voltage shall be a sine wave.
(It is recommended that the isolation voltage be measured in insulation oil.)

6.2 The business dealing name used for this product when ordered or delivered shall be PC900VONSZX.

6.3 Package specifications

Refer to the attached sheets-2-1 to 2-3.

REFERENCE

6.4 UL : Under preparation

6.5 Theory of operation

- (1) When the forward current of above the "H→L" threshold input current (I_{FHL}) is applied to the input side, the output will go "Low level".
- (2) When the forward current on the input side goes below the "L→H" threshold input current (I_{FLH}) is applied to the input side, the output will go "High level".

6.6 This product is not designed against irradiation.

This product is assembled with electrical input and output.

This product incorporates non-coherent light emitting diode.

6.7 ODS materials

This product shall not contain the following materials.

Also, the following materials shall not be used in the production process for this product.

Materials for ODS : CFC_s, Halon, Carbon tetrachloride,
1.1.1-Trichloroethane (Methylchloroform)

6.8 Brominated flame retardants

Specific brominated flame retardants such as the PBBO_s and PBB_s are not used in this device at all.

7. Notes

Refer to the attached sheet-1-1, 2.

REFERENCE

2. Outline

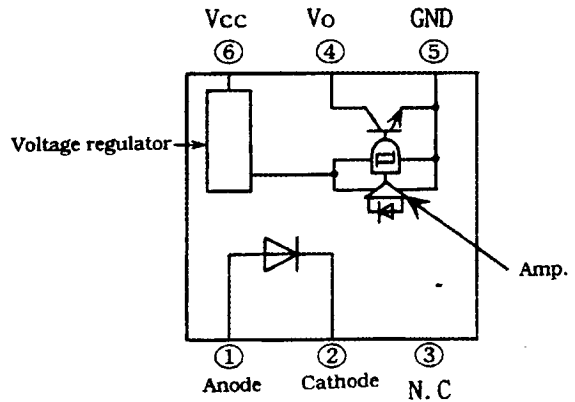
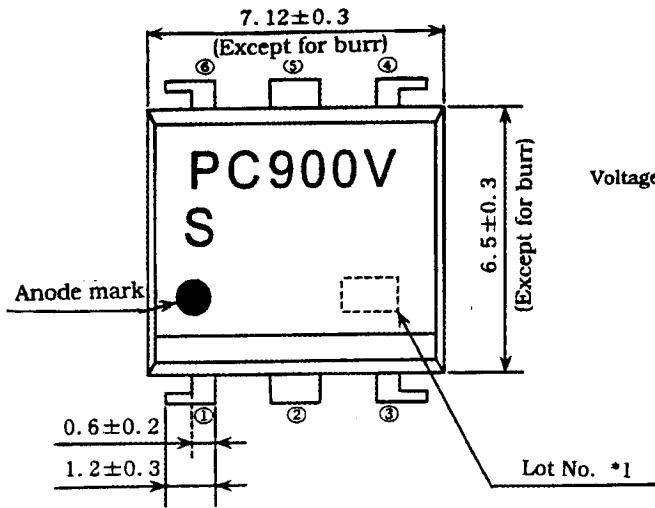

Pin Nos. and internal connection diagram

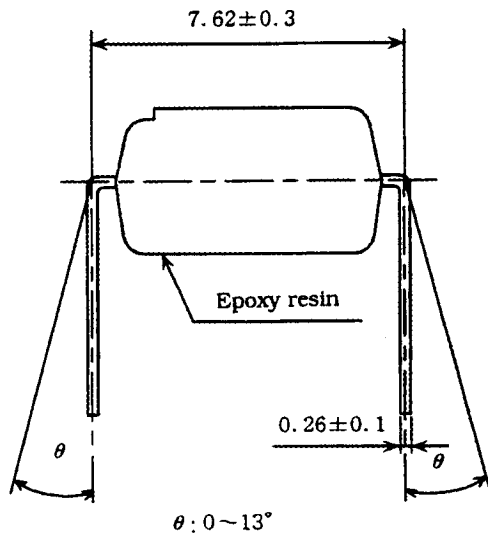
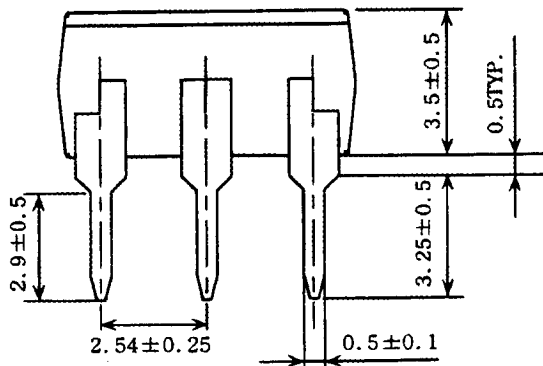

*1) 2-digit number shall be marked according to DIN standard.

*2) Marking is laser marking

Product mass : Approx. 0.36g

UNIT : 1/1 mm	
Name	PC900V Outline Dimensions (Business dealing name : PC900V0NSZX)

REFERENCE

3. Ratings and characteristics

3.1 Absolute maximum ratings

Ta=25°C

Parameter		Symbol	Rating	Unit
Input	*1 Forward current	I_F	50	mA
	*2 Peak forward current	I_{FM}	1	A
	Reverse voltage	V_R	6	V
	Power dissipation	P	70	mW
Output	Supply voltage	Vcc	16	V
	High level output voltage	V_{OH}	16	V
	Low level output current	I_{OL}	50	mA
	*1 Power dissipation	Po	150	mW
*1 Total power dissipation		Ptot	170	mW
*3 Isolation voltage		Viso(rms)	5.0	kV
Operating temperature		Topr	-25 to +85	°C
Storage temperature		Tstg	-40 to 125	°C
*4 Soldering temperature		Tsol	260	°C

*1 The derating factors of absolute maximum ratings due to ambient temperature are shown in Fig. 1, 2, 3.

*2 Pulse width $\leq 100 \mu\text{s}$, Duty ratio : 0.001

*3 AC for 1 min, 40 to 60%RH

*4 For 10 s

REFERENCE

3.2 Electro-optical characteristics

(Unspecified : Ta=0 to 70°C)

Parameter		Symbol	MIN.	TYP.	MAX.	Unit	Conditions	
Input	Forward voltage	V_F	-	1.1	1.4	V	$I_F=4mA$	
			0.7	1.0	-		$I_F=0.3mA$	
	Reverse current	I_R	-	-	10	μA	Ta=25°C, $V_R=3V$	
	Terminal capacitance	C_t	-	30	250	pF	Ta=25°C, V=0 f=1kHz	
Output	Operating supply voltage range	V_{CC}	3	-	15	V	-	
	Low level output voltage	V_{OL}	-	0.2	0.4	V	$I_{OL}=16mA$, $V_{CC}=5V$ $I_F=4mA$	
	High level output current	I_{OH}	-	-	100	μA	$V_{CC}=V_O=15V$ $I_F=0mA$	
	Low level supply current	I_{CCL}	-	2.5	5.0	mA	$V_{CC}=5V$, $I_F=4mA$	
	High level supply current	I_{CCH}	-	1.0	5.0	mA	$V_{CC}=5V$, $I_F=0mA$	
Transfer characteristics	"H→L" threshold input current *1	I_{FHL}	-	1.1	2.0	mA	Ta=25°C, $V_{CC}=5V$ $R_L=280\Omega$	
			-	-	4.0		$V_{CC}=5V$, $R_L=280\Omega$	
	"L→H" threshold input current *2	I_{FLH}	0.4	0.8	-	mA	Ta=25°C, $V_{CC}=5V$ $R_L=280\Omega$	
			0.3	-	-		$V_{CC}=5V$, $R_L=280\Omega$	
	Hysteresis *3	I_{FLH}/I_{FHL}	0.5	0.7	0.9	-	$V_{CC}=5V$, $R_L=280\Omega$	
	Isolation resistance	R_{iso}	5×10^{10}	10^{11}	-	Ω	Ta=25°C, DC500V 40 to 60%RH	
	*4 Response time	"H→L" propagation time	t_{PHL}	-	1	3	μs	Ta=25°C $V_{CC}=5V$, $I_F=4mA$ $R_L=280\Omega$
		"L→H" propagation time	t_{PLH}	-	2	6		
		Fall time	t_f	-	0.05	0.5		
		Rise time	t_r	-	0.1	0.5		

REFERENCE

- *1 I_{FHL} represents forward current when output goes from "H" to "L".
- *2 I_{FLH} represents forward current when output goes from "L" to "H".
- *3 Hysteresis : I_{FLH}/I_{FHL}
- *4 Test circuit for response time shall be shown below.

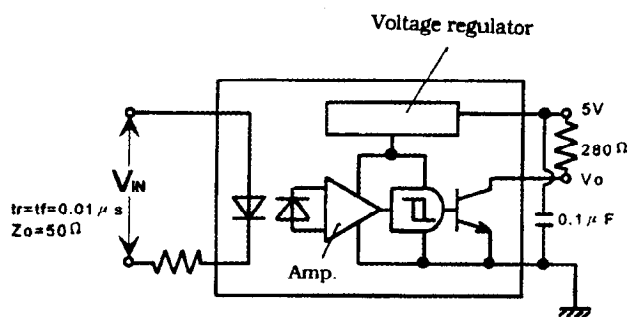

Test circuit diagram

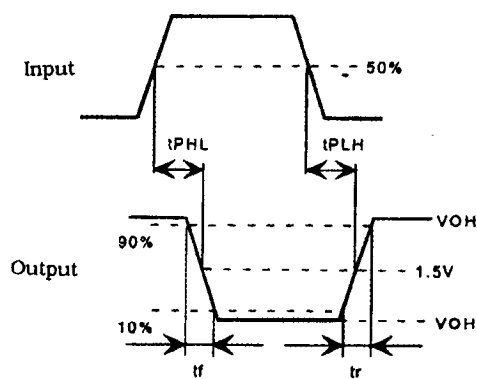

Timing chart

REFERENCE

(Fig. 1) Forward current vs. ambient temperature

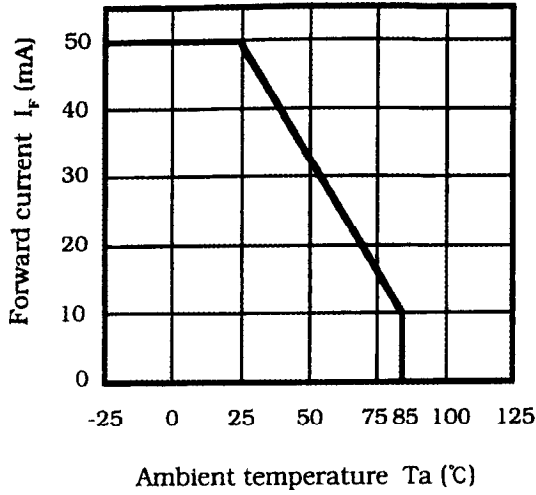

(Fig. 2) Output power dissipation vs. ambient temperature

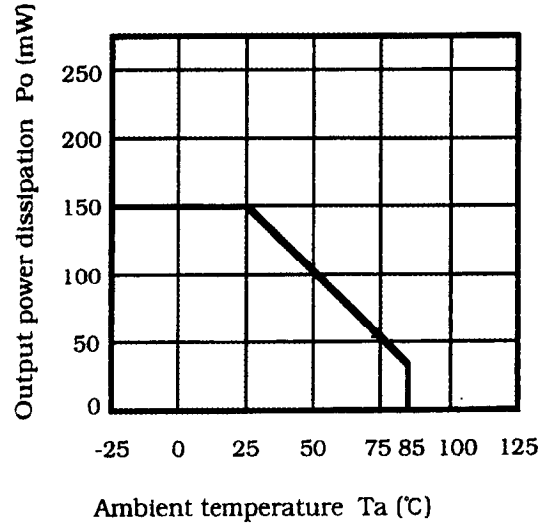

(Fig. 3) Total power dissipation vs. ambient temperature

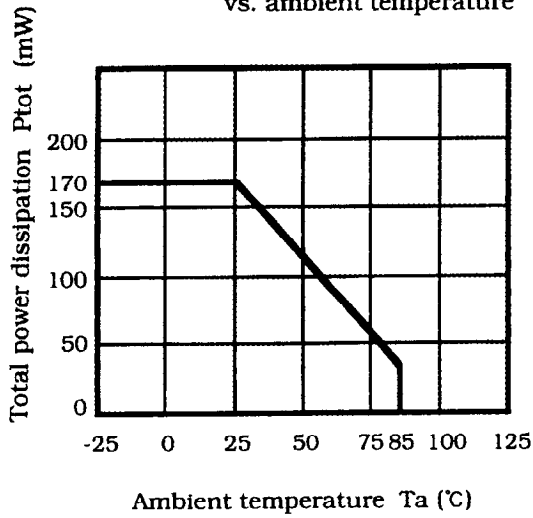

REFERENCE

4. Reliability

The reliability of products shall be satisfied with items listed below.

Confidence level : 90%
LTPD : 10%/20%

Test Items	Test Conditions *1	Failure Judgement Criteria	Samples (n)
			Defective(C)
Solderability *2	230°C, 5 s	—	n=11, C=0
Soldering heat	260°C, 10 s	$V_F > U \times 1.2$	n=11, C=0
Terminal strength (Tension)	Weight : 5N 5 s/each terminal	$I_R > U \times 2$	n=11, C=0
Terminal strength (Bending) *3	Weight : 2.5N 2 times/each terminal	$V_{OL} > U \times 1.2$ $I_{OH} > U \times 1.2$	n=11, C=0
Mechanical shock	15km/s ² , 0.5ms 3 times/±X, ±Y, ±Z direction	$I_{CCL} > U \times 1.2$ $I_{CCH} > U \times 1.2$	n=11, C=0
Variable frequency vibration	100 to 2000 to 100Hz/4min 200m/s ² 4 times/ X, Y, Z direction	$I_{FHL} > U \times 1.3$ $I_{FLH} < L \times 0.7$	n=11, C=0
Temperature cycling	1 cycle -40°C to +125°C (30min) (30min) 20 cycles test	$I_{FLH}/I_{FHL} \neq L \times 0.8$ ~U×1.2	n=22, C=0
High temp. and high humidity storage	+85°C, 85%RH, 1000h	U : Upper specification limit L : Lower specification limit	n=22, C=0
High temp. storage	+125°C, 1000h		n=22, C=0
Low temp. storage	-40°C, 1000h		n=22, C=0
Operation life	$I_F = 10\text{mA}$, $V_{CC} = 15\text{V}$ $I_{OL} = 16\text{mA}$, $T_a = 25^\circ\text{C}$, 1000h		n=22, C=0

*1 Test method, conforms to EIAJ ED 4701.

*2 Solder shall adhere at the area of 95% or more of immersed portion of lead, and pin hole or other holes shall not be concentrated on one portion.

*3 Terminal bending direction is shown below.

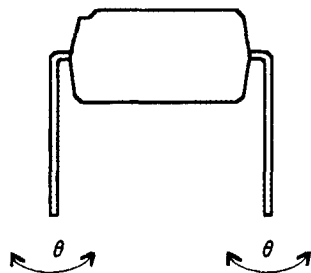

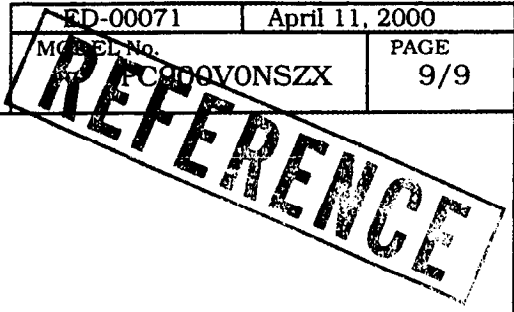

5. Outgoing inspection

5.1 Inspection items

(1) Electrical characteristics

V_F , I_R , V_{OL} , I_{OH} , I_{CCL} , I_{CCH} , I_{FHL} , I_{FLH} , Riso, Viso

(2) Appearance

5.2 Sampling method and Inspection level

A single sampling plan, normal inspection level II based on ISO 2859 is applied. The AQL according to the inspection items are shown below.

Defect	Inspection item	AQL (%)
Major defect	Electrical characteristics Unreadable marking	0.065
Minor defect	Appearance defect except the above mentioned.	0.25

REFERENCEPrecautions for Photocouplers

1 For cleaning

- (1) Solvent cleaning : Solvent temperature 45°C or less
Immersion for 3 min or less
- (2) Ultrasonic cleaning : The effect to device by ultrasonic cleaning differs by cleaning bath size, ultrasonic power output, cleaning time, PCB size or device mounting condition etc. Please test it in actual using condition and confirm that doesn't occur any defect before starting the ultrasonic cleaning.
- (3) Applicable solvent : Ethyl alcohol, Methyl alcohol, Isopropyl alcohol

In case when the other solvent is used, there are cases that the packaging resin is eroded. Please use the other solvent after thorough confirmation is performed in actual using condition.

2. Please use the same as normal integration circuit about static electricity in order that this device is OPIC photocoupler.
3. In order to stabilize power supply line, we recommend to connect a by-pass capacitor of 0.01 μ F or more between Vcc and GND near the device.
4. The detector which is used in this device, has parasitic diode between each pins and GND. There are cases that miss operation or destruction possibly may be occurred if electric potential of any pin becomes below GND level even for instant. Therefore it shall be recommended to design the circuit that electric potential of any pin does not become below GND level.
5. The LED used in the Photocoupler generally decreases the light emission power by operation. In case of long operation time, please design the circuit with considering the decreases of the light emission power of the LED. (50%/5years)
Please decide the input current which become 2 times of MAX. I_{FHL} .

REFERENCE

6. Precautions for Soldering Photocouplers

- (1) In case of soldering to lead
260°C 10 s or less

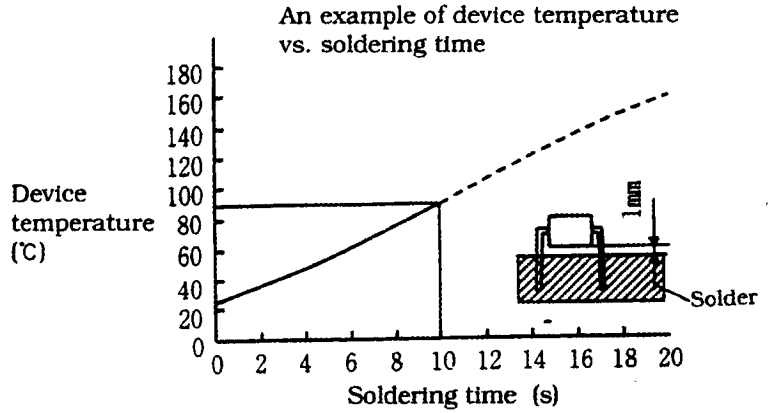

- (2) If solder reflow :

It is recommended that only one soldering be done at the temperature and the time within the temperature profile as shown in the figure below.

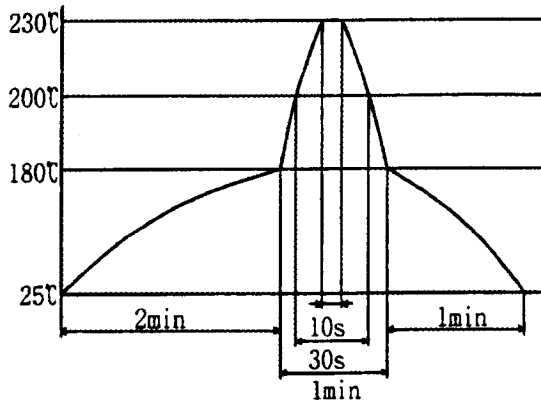

- (3) Other precautions

An infrared lamp used to heat up for soldering may cause a localized temperature rise in the resin. So keep the package temperature within that specified in Item (2). Also avoid immersing the resin part in the solder.

Package specification

1 Package materials

No.	Name	Materials	Purposes
1	Sleeve	Plastics with preventing static electricity	Products packaged
2	Stopper	Rubber	Products fixed
3	Packing case	Corrugated cardboard	Sleeve packaged
4	Kraft tape	Paper	Lid of packaged case fixed
5	Label	Paper	Model No., quantity, inspection date and lot No. specified

2 Package method

- (1) MAX. 50pcs. of products shall be packaged in a sleeve and both of sleeve edges shall be fixed by stoppers.
- (2) MAX. 20 sleeves above shall be packaged in a packing case and pack a sheet of cushion at one side.
- (3) Model No., quantity, inspection date and lot No. shall be marked on the label and this label shall be put on the side of the packaging case.
- (4) Case shall be closed with the lid and enclosed with kraft tape.

3 Package outline dimensions

- (1) Sleeve outline dimensions
Refer to the attached sheets-2-2.
- (2) Packaging case outline dimensions
Refer to the attached sheets-2-3.

REFERENCE

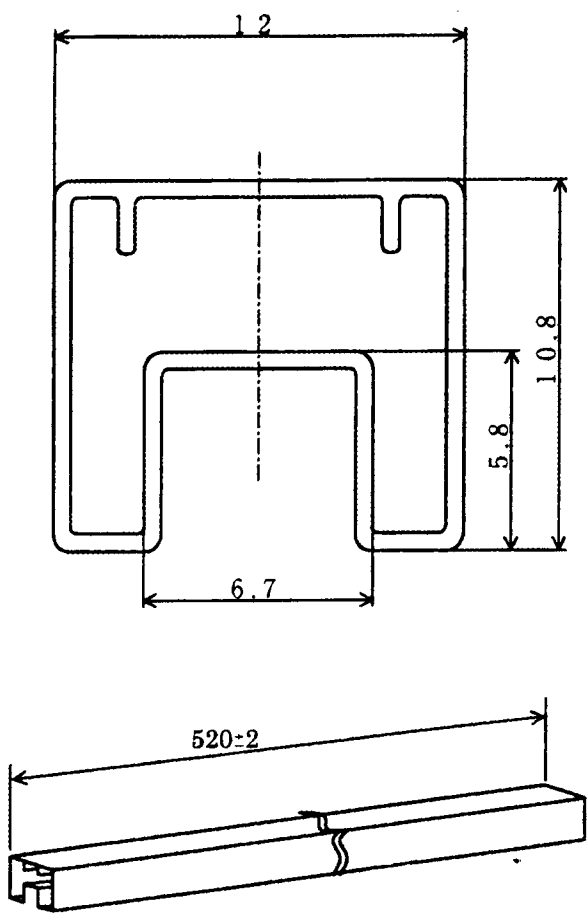

Length : L=520 ± 2mm

- Note 1) Thickness : 0.5±0.2mm
- 2) Outer R : 0.5mm
- 3) Process with applying antistatic agent.
- 4) Unless otherwise specified tolerances shall be ±0.5mm.
(However except for deformation due to the rubber stopper in sleeve.)

Unit : 1/1mm	
Name	Sleeve outline dimensions

REFERENCE

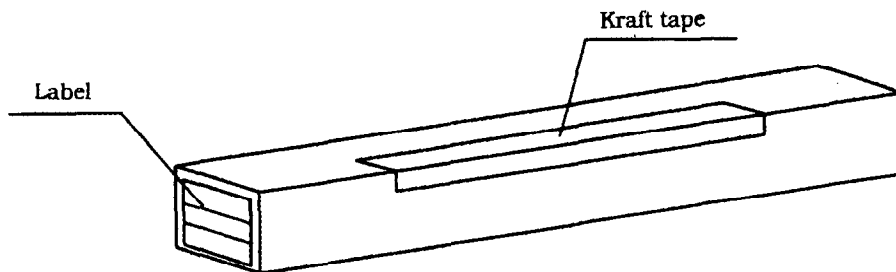
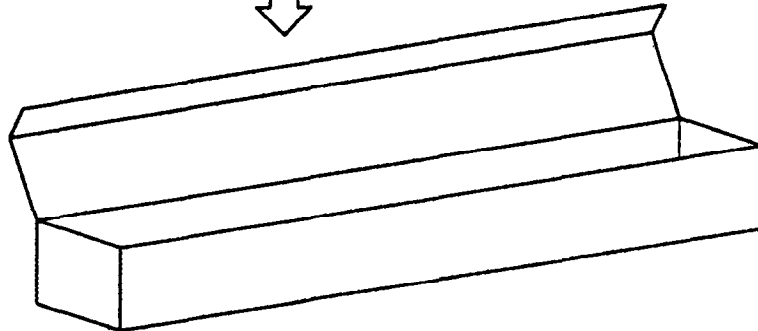
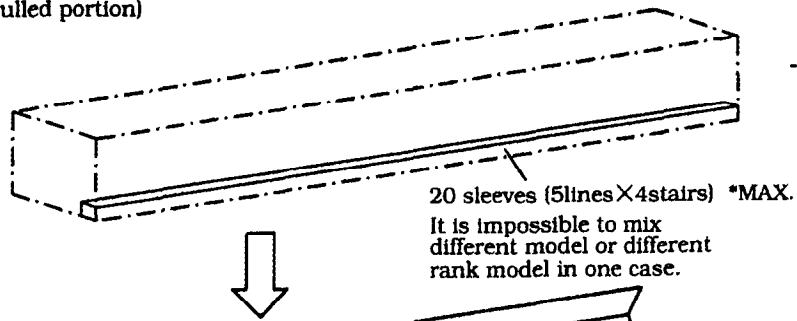
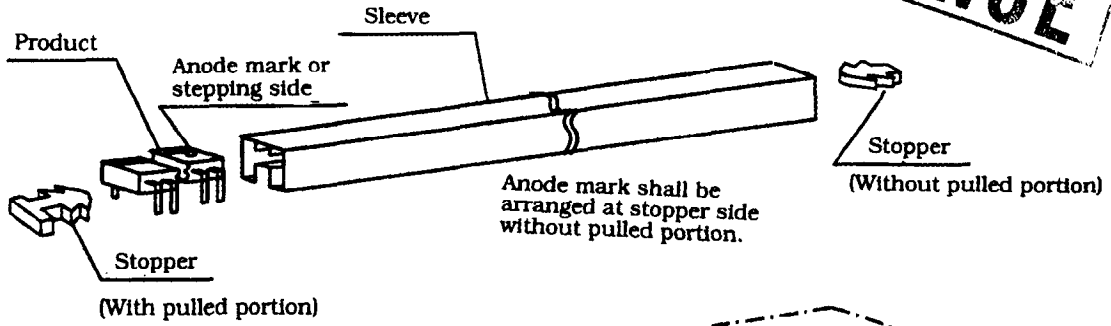

Unit: 1/1mm	
Name	Packing case outline dimensions