



TYPE FSDVA

For Reflow Soldering

Frequency Range : 0.05 ~ 15MHz

Inductance Range : 0.1 ~ 52mH

1 ~ 7mH (for corner censor)

Q Approx : 20 ~ 60

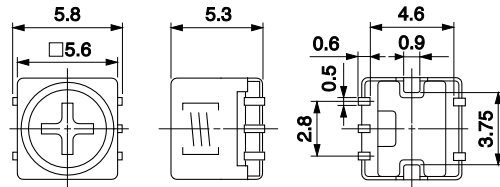

(Unit: mm)

Recommended patterns

推奨パターン図

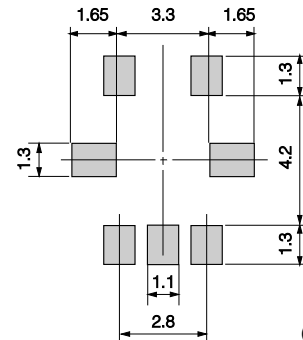

(Unit: mm)

Features

- Highly durable against mechanical stress.
- Wide operating temperature range
 ~ 20mH (-40~+105°C).
 20mH ~ (-40~+85°C).
- 1,000 hours guarantee in reliability characteristics based on evaluation test up to 3,000 hours.
- Terminal coplanarity: 0.1mm Max.
- AEC-Q200 compliant.

特長

- 機械的ストレスに強い
- 使用温度範囲 ~ 20mH (-40~+105°C)
 20mH ~ (-40~+85°C)
- 各種信頼性は、1,000時間の保証 (3,000時間迄の評価を実施)
- 端子の平坦度0.1mm以内の保証
- AEC-Q200準拠

TYPE FSDVA

品番	測定周波数	L可変範囲	Q	内部接続 *
Part Number	Test Frequency (kHz)	L Range (mH)	Unloaded Q	Winding Connection *
N1342BCA-0004UG=P3	252	4.4 ±3%	25 min	B
N1342DEA-0008BQE=P3	252	2.5 ±5%	25 min	C

品番	測定周波数	L許容範囲	Q	内部接続 *
Part Number	Test Frequency (kHz)	L Tolerance (mH)	Unloaded Q	Winding Connection *
N1342AAA-0001Z=P3	79.6	52 ±7%	10 min	A

*Connection A (Bottom View)

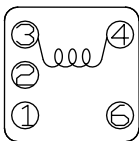

* Connection B (Bottom View)

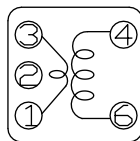

* Connection C (Bottom View)

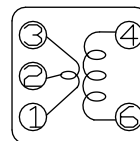

FSDVA type is customized item. Please feel free to contact us for details.
 FSDVAはカスタム仕様品です。詳細についてはお問い合わせ下さい。