

HFA35HB60

HEXFRED™

Ultrafast, Soft Recovery Diode

Features

- Reduced RFI and EMI
- Reduced Snubbing
- Extensive Characterization of Recovery Parameters
- Hermetic
- Electrically Isolated
- Ceramic Eyelets

$V_R = 600V$
$V_F = 1.75V$
$Q_{rr} = 290nC$
$di_{(rec)}/dt = 400A/\mu s$

Description

HEXFRED™ diodes are optimized to reduce losses and EMI/RFI in high frequency power conditioning systems. An extensive characterization of the recovery behavior for different values of current, temperature and di/dt simplifies the calculations of losses in the operating conditions. The softness of the recovery eliminates the need for a snubber in most applications. These devices are ideally suited for power converters, motors drives and other applications where switching losses are significant portion of the total losses.

Absolute Maximum Ratings

	Parameter	Max.	Units
V_R	D.C. Reverse Voltage	600	V
$I_F @ T_C = 100^\circ C$	Continuous Forward Current ①	22	A
$I_{FSM} @ T_C = 25^\circ C$	Single Pulse Forward Current ②	225	
$P_D @ T_C = 25^\circ C$	Maximum Power Dissipation	83	W
T_J T_{STG}	Operating Junction and Storage Temperature Range	-55 to +150	°C

Note: ① D.C. = 50% rect. wave
 ② 1/2 sine wave, 60 Hz , P.W. = 8.33 ms

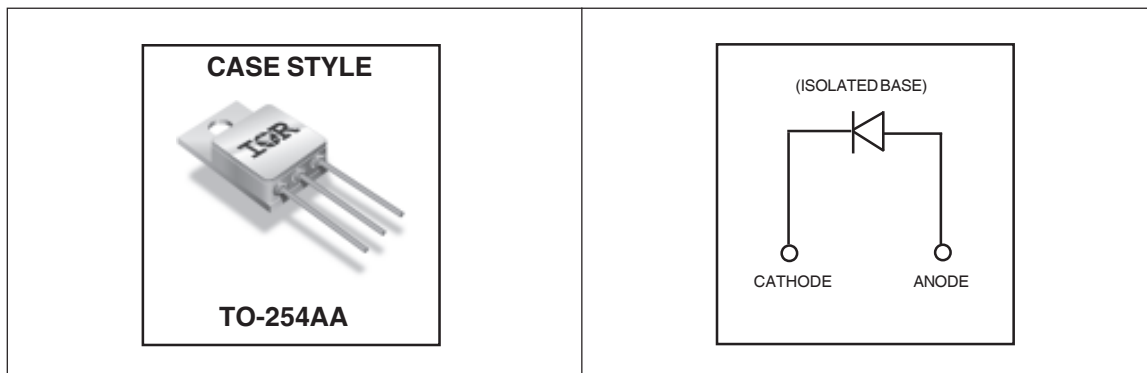

Electrical Characteristics @ $T_J = 25^\circ\text{C}$ (unless otherwise specified)

	Parameter	Min.	Typ.	Max.	Units	Test Conditions
V_{BR}	Cathode Anode Breakdown Voltage	600	—	—	V	$I_R = 100\mu\text{A}$
V_{FM}	Max Forward Voltage	—	—	1.75	V	$I_F = 22\text{A}$
		—	—	2.25		$I_F = 45\text{A}$ See Fig. 1
		—	—	1.64		$I_F = 22\text{A}, T_J = 125^\circ\text{C}$
I_{RM}	Max Reverse Leakage Current	—	—	10	μA	$V_R = V_R$ Rated See Fig. 2
		—	—	1.0	mA	$T_J = 125^\circ\text{C}, V_R = 480\text{V}$
C_T	Junction Capacitance	—	56	59	pF	$V_R = 200\text{V}$ See Fig. 3
L_S	Series Inductance	—	8.7	—	nH	Measured from center of bond pad to end of anode bonding wire

Dynamic Recovery Characteristics @ $T_J = 25^\circ\text{C}$ (unless otherwise specified)

	Parameter	Min.	Typ.	Max.	Units	Test Conditions
t_{rr1}	Reverse Recovery Time	—	60	97	ns	$T_J = 25^\circ\text{C}$ See Fig. 5
t_{rr2}		—	110	165		$T_J = 125^\circ\text{C}$
I_{RRM1}	Peak Recovery Current	—	5.2	7.8	A	$T_J = 25^\circ\text{C}$ See Fig. 6
I_{RRM2}		—	8.5	13		$T_J = 125^\circ\text{C}$
Q_{rr1}	Reverse Recovery Charge	—	190	290	nC	$T_J = 25^\circ\text{C}$ See Fig. 7
Q_{rr2}		—	560	840		$T_J = 125^\circ\text{C}$
$di_{(rec)M}/dt1$	Peak Rate of Fall of Recovery Current	—	270	400	$\text{A}/\mu\text{s}$	$T_J = 25^\circ\text{C}$ See Fig. 8
$di_{(rec)M}/dt2$		During t_b	—	170		250

Thermal - Mechanical Characteristics

	Parameter	Typ.	Max.	Units
$R_{\theta JC}$	Junction-to-Case, Single Leg Conducting	—	1.5	$^\circ\text{C}/\text{W}$
Wt	Weight	9.3	—	g

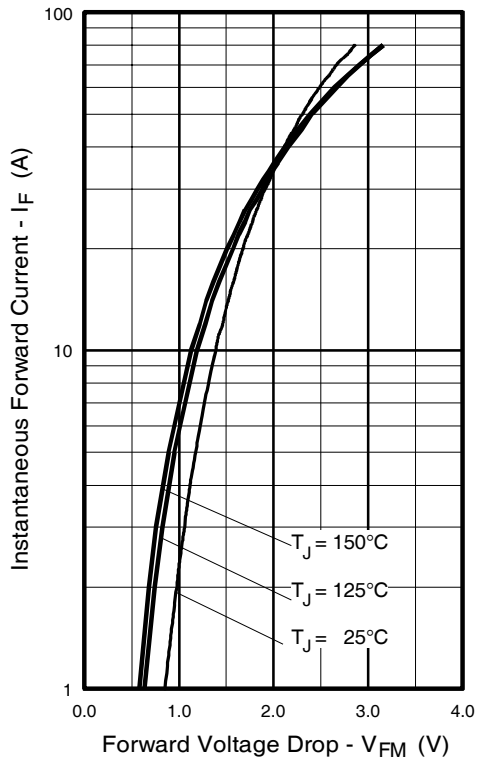

Fig. 1 - Maximum Forward Voltage Drop vs. Instantaneous Forward Current

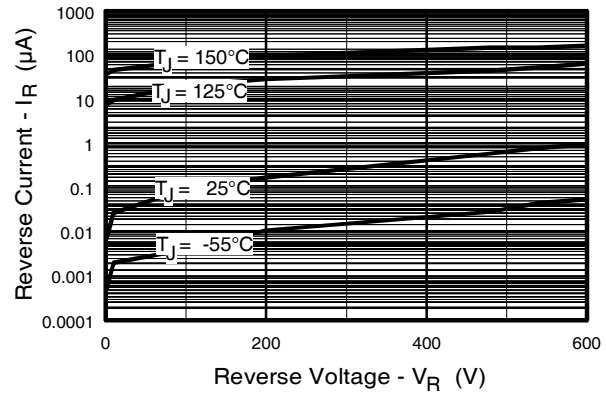

Fig. 2 - Typical Reverse Current vs. Reverse Voltage

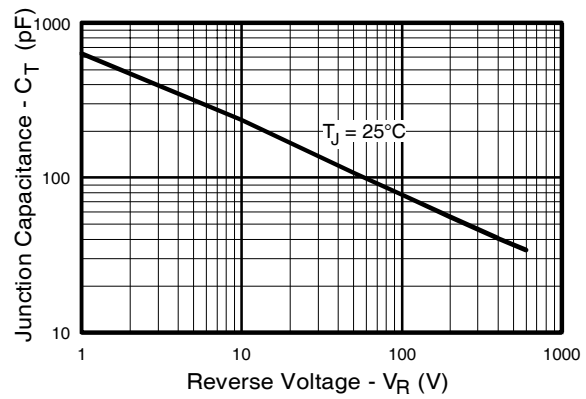

Fig. 3 - Typical Junction Capacitance vs. Reverse Voltage

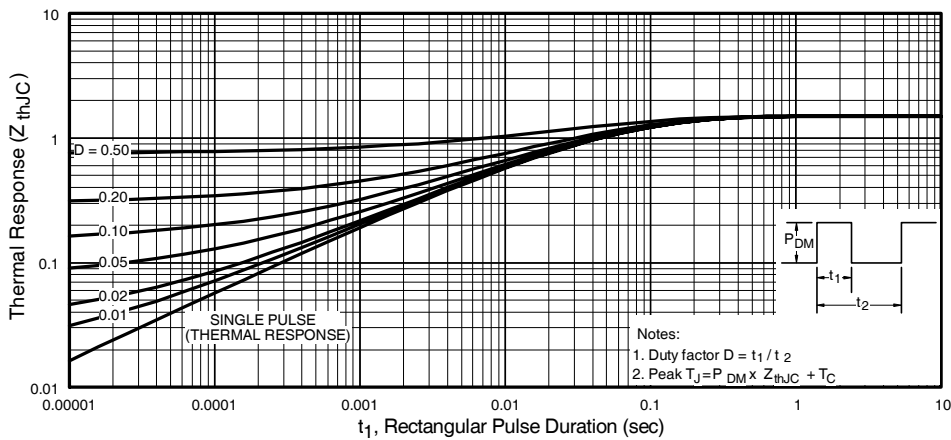

Fig. 4 - Maximum Thermal Impedance Z_{thJC} Characteristics

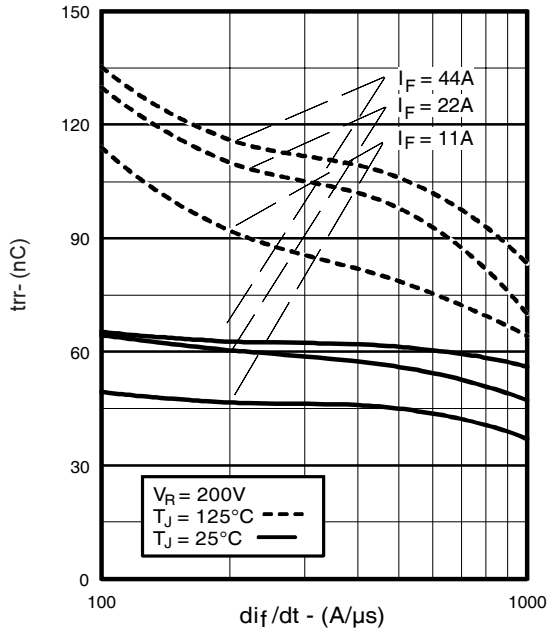

Fig. 5 - Typical Reverse Recovery vs. di_f/dt

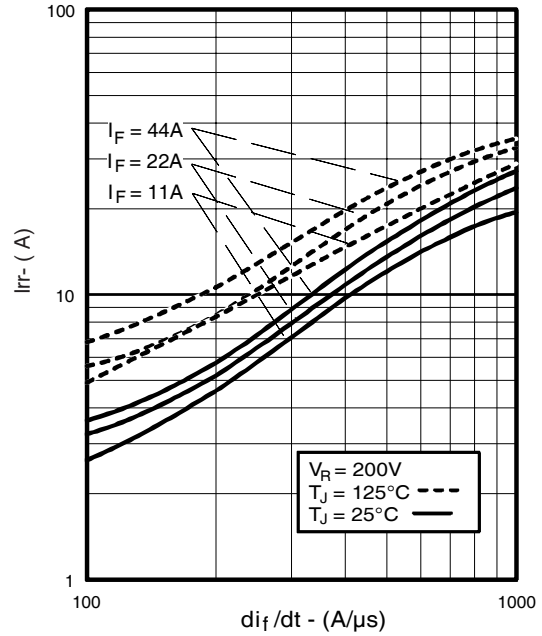

Fig. 6 - Typical Recovery Current vs. di_f/dt

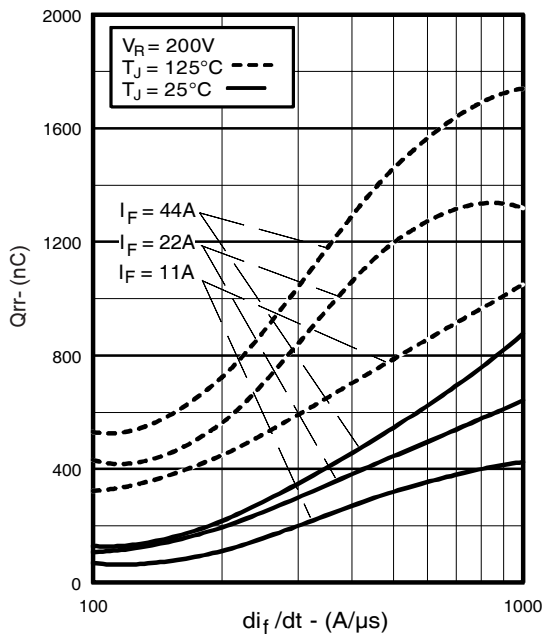

Fig. 7 - Typical Stored Charge vs. di_f/dt

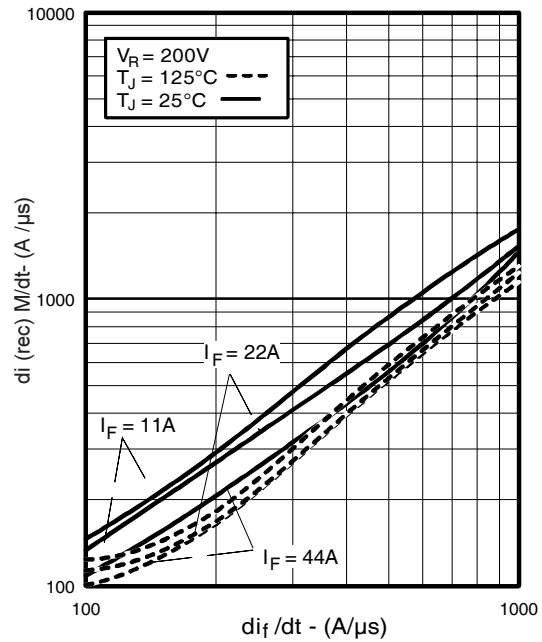

Fig. 8 - Typical $di_{(rec)}M/dt$ vs. di_f/dt

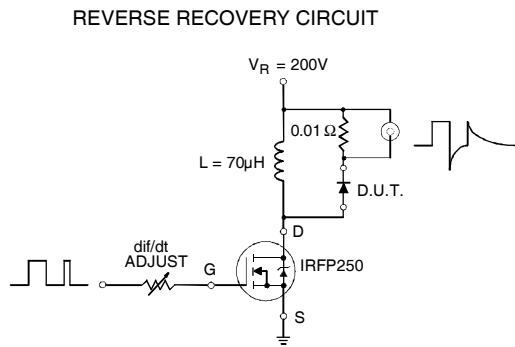
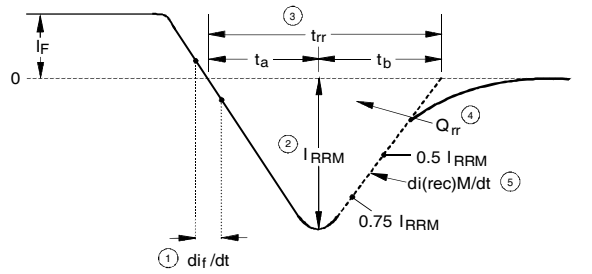

Fig. 9 - Reverse Recovery Parameter Test Circuit



1. di_f/dt - Rate of change of current through zero crossing
2. I_{RRM} - Peak reverse recovery current
3. t_{rr} - Reverse recovery time measured from zero crossing point of negative going I_f to point where a line passing through $0.75 I_{RRM}$ and $0.50 I_{RRM}$ extrapolated to zero current
4. Q_{rr} - Area under curve defined by t_{rr} and I_{RRM}
5. $di_{(rec)M}/dt$ - Peak rate of change of current during t_b portion of t_{rr}

$$Q_{rr} = \frac{t_{rr} \times I_{RRM}}{2}$$

Fig. 10 - Reverse Recovery Waveform and Definitions

Case Outline and Dimensions — TO-254AA

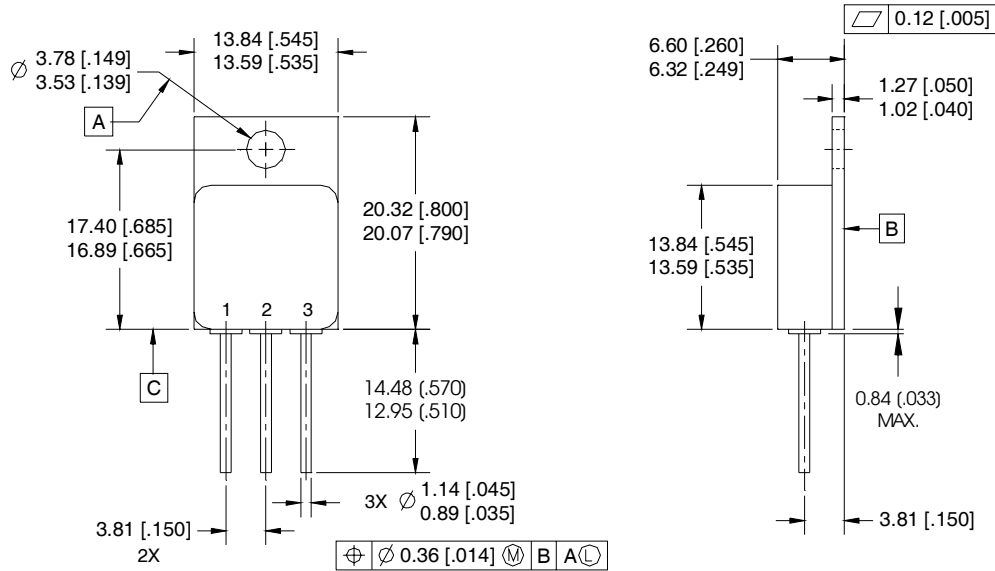

NOTES:

1. DIMENSIONING & TOLERANCING PER ASME Y14.5M-1994.
2. ALL DIMENSIONS ARE SHOWN IN MILLIMETERS (INCHES).
3. CONTROLLING DIMENSION: INCH.
4. CONFORMS TO JEDEC OUTLINE TO-254AA.

PIN ASSIGNMENTS

- 1 = CATHODE
- 2 = N/C
- 3 = ANODE

CAUTION

BERYLLIA WARNING PER MIL-PRF-19500

Package containing beryllia shall not be ground, sandblasted, machined, or have other operations performed on them which will produce beryllia or beryllium dust. Furthermore, beryllium oxide packages shall not be placed in acids that will produce fumes containing beryllium.