



# TAI-SAW TECHNOLOGY CO., LTD.

No. 3, Industrial 2nd Rd., Ping-Chen Industrial District,  
Taoyuan, 324, Taiwan, R.O.C.

TEL: 886-3-4690038 FAX: 886-3-4697532

E-mail: [tstsales@mail.taisaw.com](mailto:tstsales@mail.taisaw.com) Web: [www.taisaw.com](http://www.taisaw.com)

## Product Specifications Approval Sheet

Issued Date:

Product Name: SAW IF Filter 751.5 MHz ( package 5.0mm x 5.0 mm )

TST Parts No.: TB0903A

Customer Parts No.: \_\_\_\_\_

Customer signature required
Company: _____
Division: _____
Approved by : _____
Date: _____

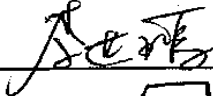
Checked by: \_\_\_\_\_ Kazuma Lee 

Approval by: \_\_\_\_\_ Francis Chen 

Date: \_\_\_\_\_ 10 / 11 / 2010

1. Customer signed back is required before TST can proceed with sample build and receive orders.
2. Orders received without customer signed back will be regarded as agreement on the specifications.
3. Any specifications changes must be approved upon by both parties and a new revision of specifications shall be released to reflect the changes.



# TAI-SAW TECHNOLOGY CO., LTD.

No.3, Industrial 2nd Rd., Ping-Chen Industrial District, Taoyuan, Taiwan, R.O.C.

TEL: 886-3-4690038 FAX: 886-3-4697532

E-mail: [tstsales3@mail.taisaw.com](mailto:tstsales3@mail.taisaw.com) Web: [www.taisaw.com](http://www.taisaw.com)

SAW Filter 751.5MHz 65MHz BW (SMD 5.0×5.0 mm)

MODEL NO.: TB0903A

REV. NO.1

## A. MAXIMUM RATING:

1. Operating temperature range: -30°C to 85°C
2. Storage temperature range: -40°C to 85°C
3. Input Power Level : 10 dBm
4. Maximum DC Voltage : 10V

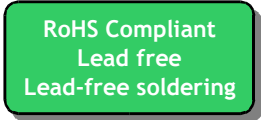

## B. Characteristics :

Item	Unit	Min.	Type.	Max.
Center frequency, Fc	MHz	-	751.5	-
Insertion Loss, IL	dB	-	12.3	15.0
-1dB bandwidth	MHz	65	73	-
Passband Ripple Fc+/- 32MHz	dB	-	0.6	1.0
Attenuation:(Reference level from Min IL)				
10MHz ~ 600MHz	dB	40	50	
600MHz ~ 680MHz	dB	40	50	
820MHz ~ 895MHz	dB	40	48	
895MHz ~ 1000MHz	dB	40	49	
Temperature Coefficient	ppm/°C	-	-94	-
Source Impedance	Ohm	-	50	-
Load Impedance	Ohm	-	50	-

### C. Frequency Characteristics :

(1) Wide band Response:(span 400MHz)

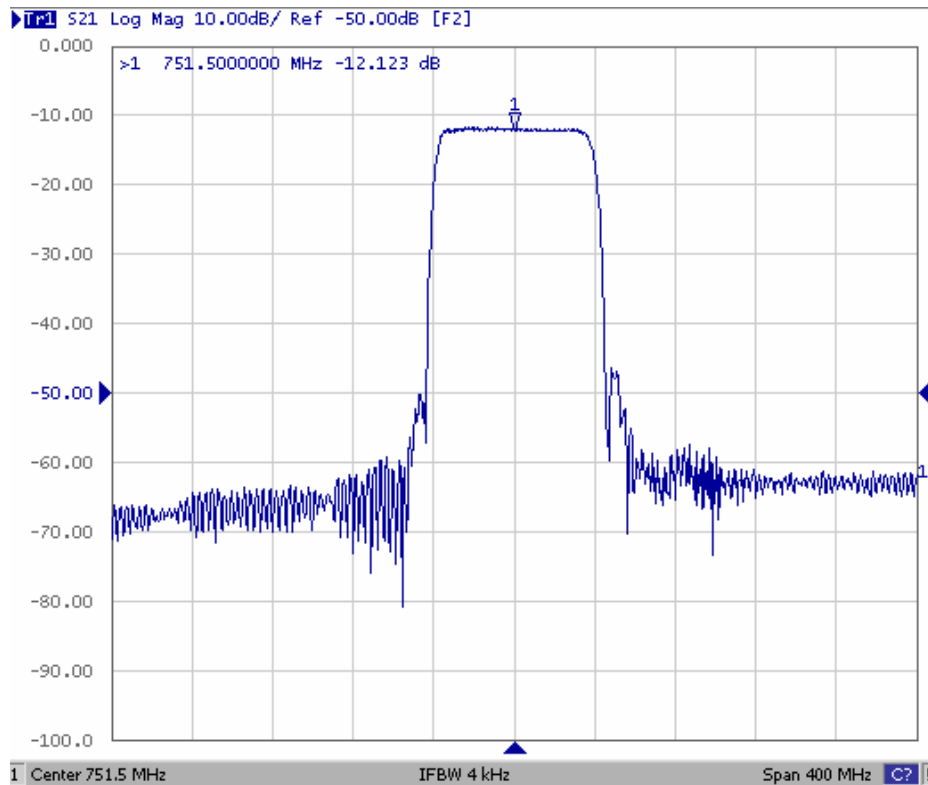

Fig1. Horizontal: 40MHz/Div Vertical: 10dB/Div

(2) Pass band Response and Group Time Delay response:

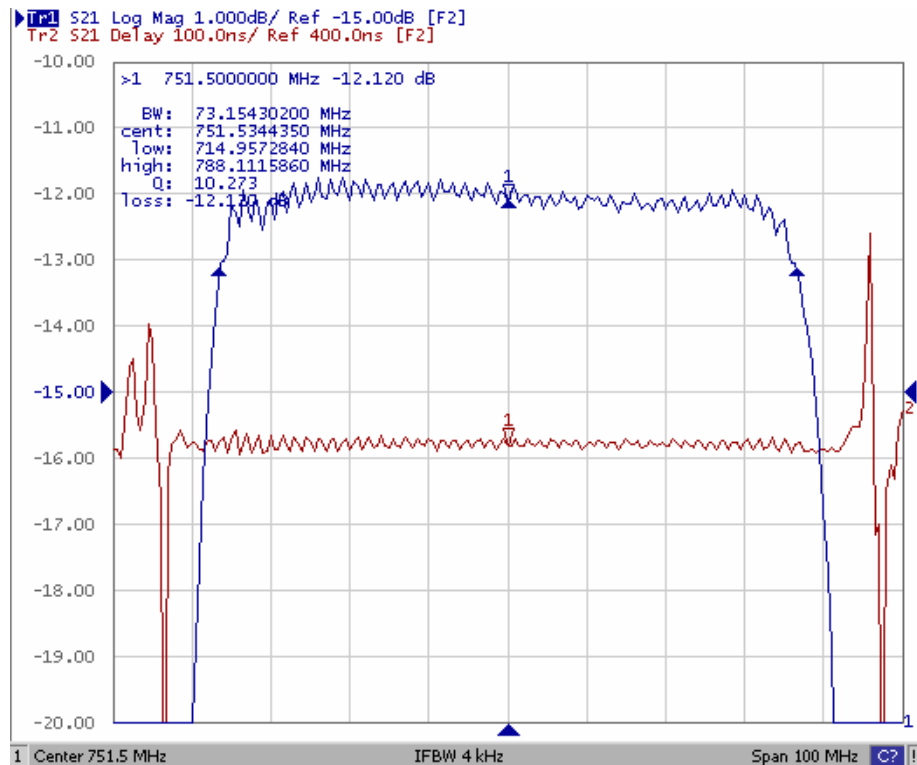

Fig2. Horizontal: 10MHz/Div Vertical: 1dB/Div  
Vertical: 100ns/Div

(3) Wide band Response:

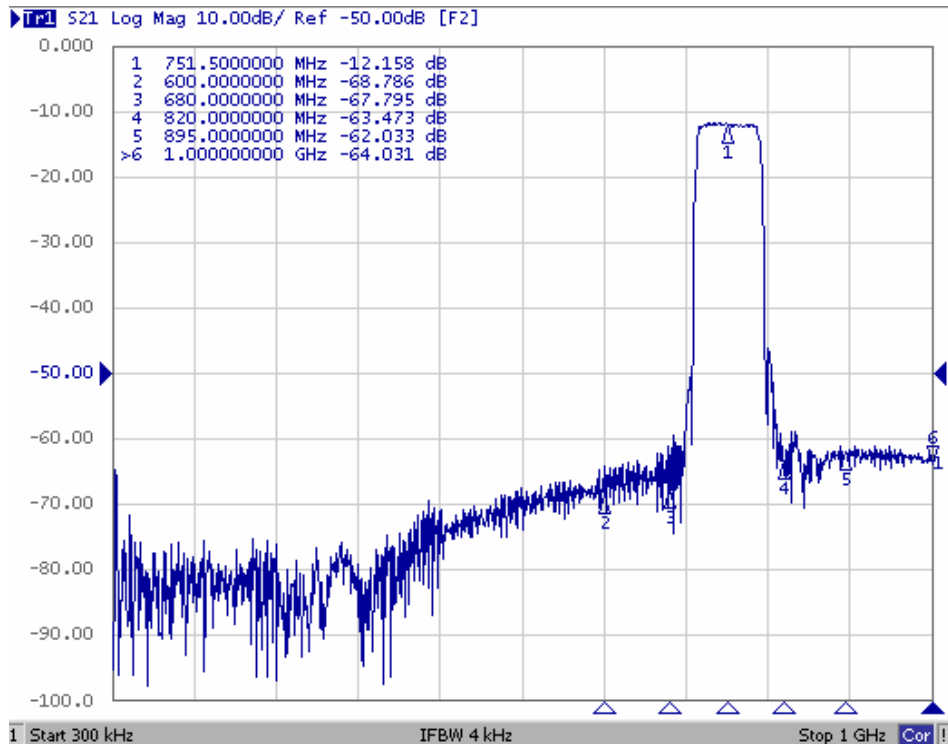
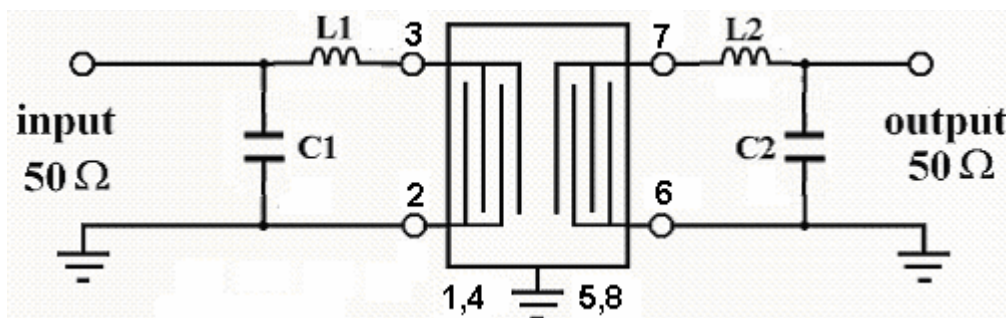

Fig3. Horizontal: 100MHz/Div Vertical: 10dB/Div

D. Matching Circuit:



L1 = 3 nH, C1 = 4.7 pF, L2 = 5.6 nH, C2 = 3.3 pF

**E. Outline Drawing:**

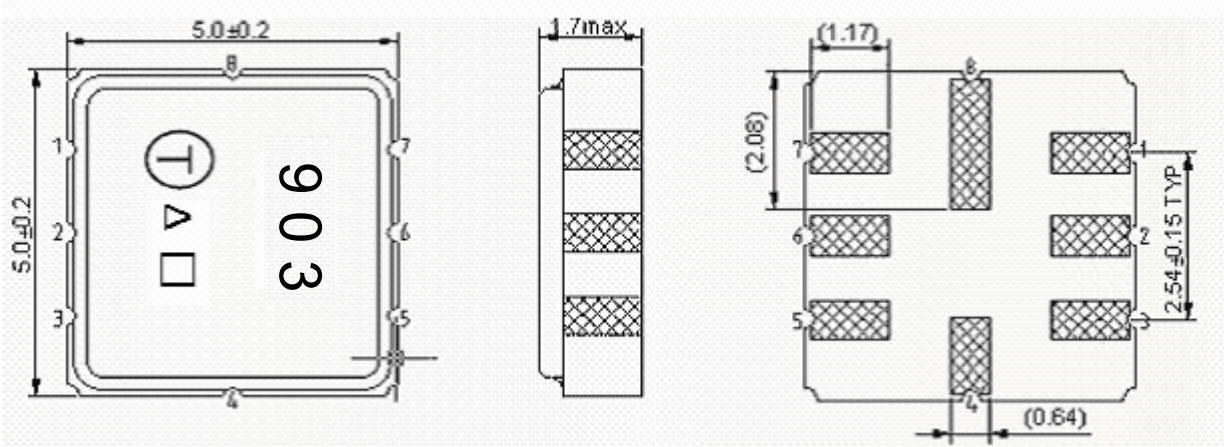

#3 –Input

#2 –Input ground

#7 – Output

#6 – Output ground

#1,4,5,8 – Ground

□ : Week Code (Follow the table from planner each year)

Unit : mm

△ : Product / Year Code

Year	2005 2009	2006 2010	2007 2011	2008 2012
Product Code	B	b	<u>B</u>	<u>b</u>

**F. PCB Footprint:**

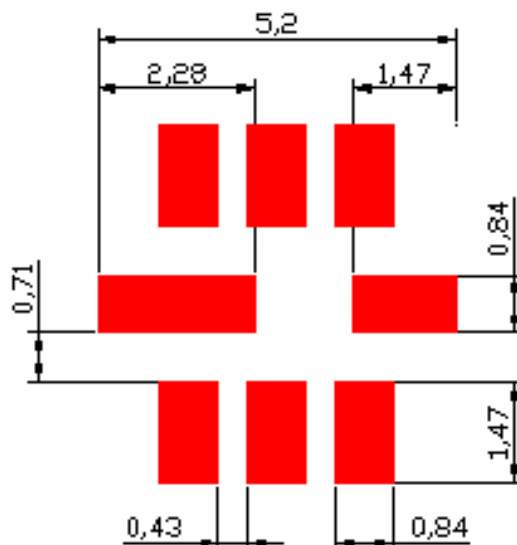

## G. PACKING:

### 1. REEL DIMENSION:

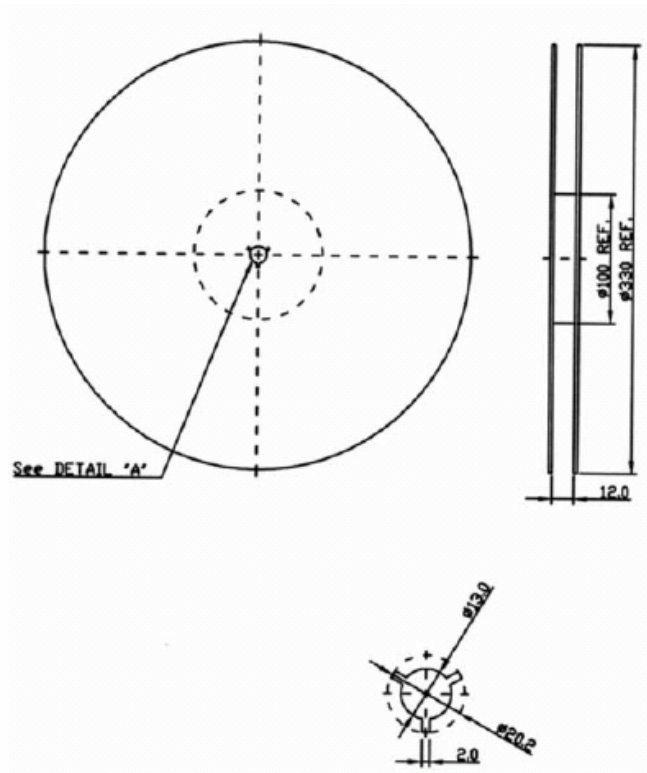

### 2. TAPE DIMENSION:

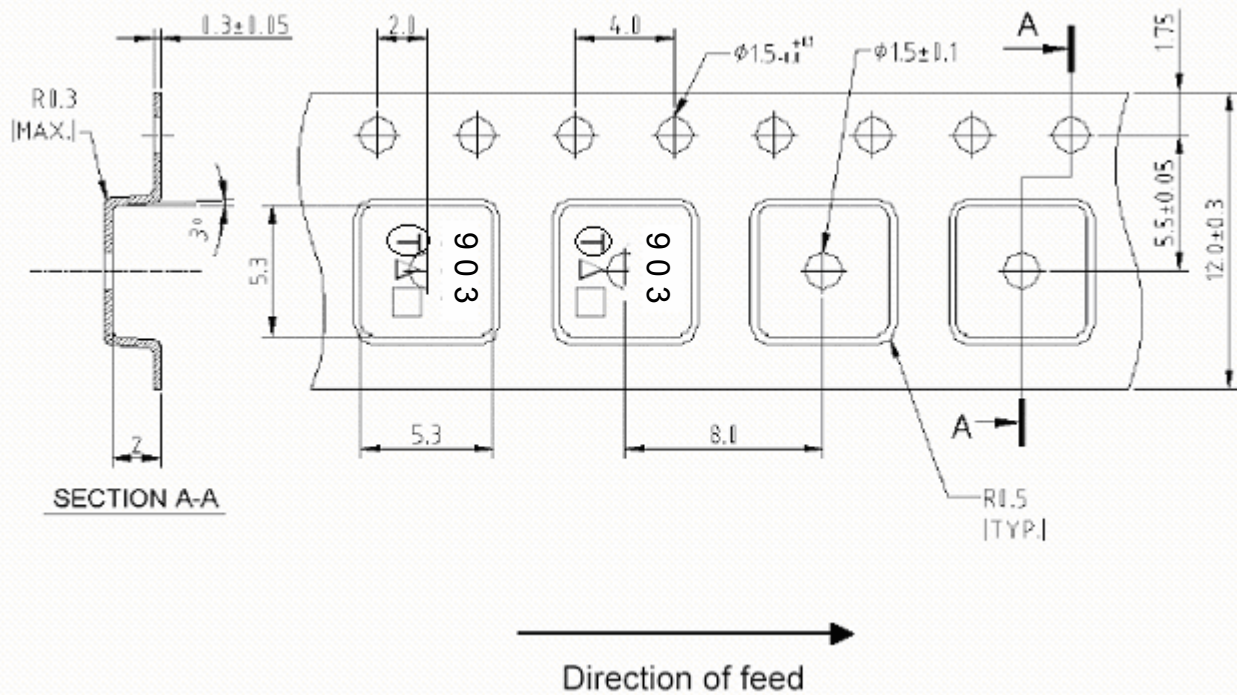

## H. RECOMMENDED REFLOW PROFILE.:

